

(No Model.)

F. W. ARVINE.  
CRYSTALLIZING AND SETTING BOX.

No. 486,015.

Patented Nov. 8, 1892.

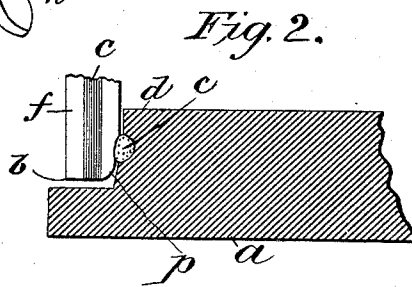
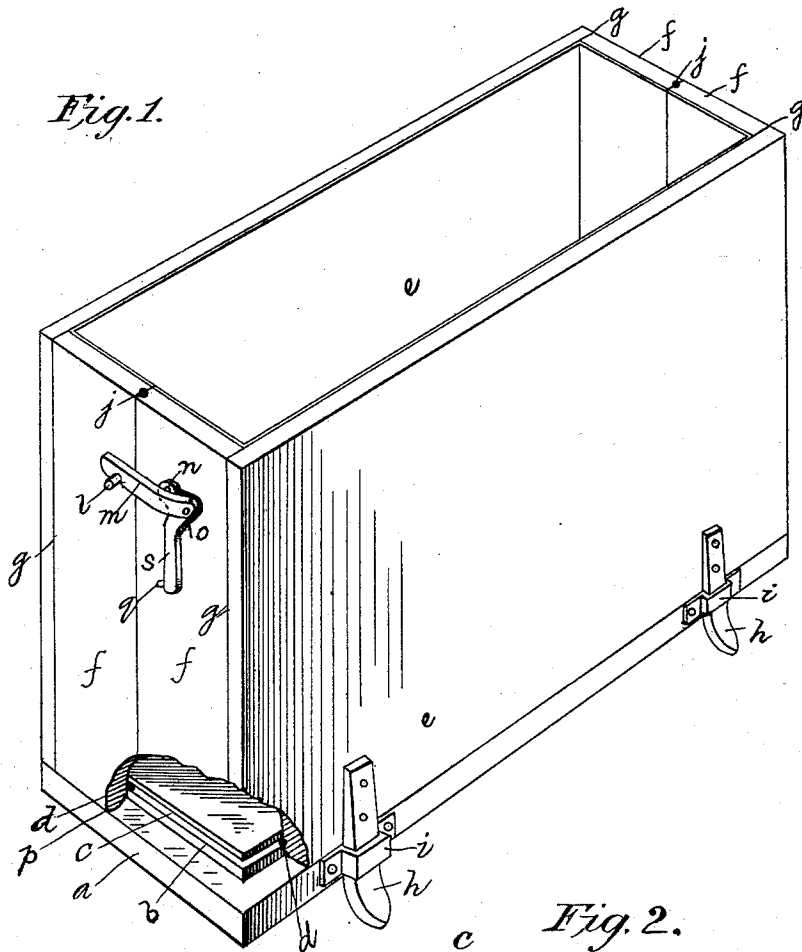

Attest,  
G. W. Benjamin.  
C. J. Jullongau

Inventor:  
F. W. Arvine  
By A. P. Thayer atty

# UNITED STATES PATENT OFFICE.

FREELING W. ARVINE, OF PORT RICHMOND, NEW YORK.

## CRYSTALLIZING AND SETTING BOX.

SPECIFICATION forming part of Letters Patent No. 486,015, dated November 8, 1892.

Application filed November 25, 1891. Serial No. 413,059. (No model.)

*To all whom it may concern:*

Be it known that I, FREELING W. ARVINE, a citizen of the United States, residing at Port Richmond, county of Richmond, and State of New York, have invented certain new and useful Improvements in Crystallizing and Setting Boxes, of which the following is a full, clear, and exact description, reference being had to the accompanying drawings, and to the letters of reference marked thereon.

My invention consists in an improved construction of boxes for crystallizing or setting chemical substances, in parts adapted for cheaper construction and being more readily put together with tightly-packed joints, and to be likewise more readily taken apart for removal of the crystallized material, as hereinafter fully described, reference being made to the accompanying drawings, in which—

Figure 1 is a perspective view of a box constructed according to my invention with a part broken out, and Fig. 2 is a detail showing the bevel corners of the end pieces to prevent cutting the packing.

The bottom of the box consists of a plate *a*, having the rabbet-groove *b* all around the margin of the upper side, in the vertical wall of which rabbet is a packing-groove *c*, in which a rope *d*, of fibrous or other approved packing, is placed, said packing projecting about half its diameter from the said wall.

The side plates *e*, each having half the end pieces *f* fastened to them at *g* in any approved way, are adapted to be seated at the lower edge in the said rabbet of the bottom plate and have horn-cleats *h* projecting from the lower edge of the outside, suitably to enter the socket-clips *i*, fastened to the edge of the bottom plate to secure the sides thereto, said horn-cleats being suitably curved and the clips adapted for tightening the sides against the packing and tightening the ends of the divided end pieces when the sides are closed up toward each other after entering the horn-cleats in the socket-clips. The meeting ends of the divided end pieces of the box are also grooved and fitted with packing *j*, which is compressed and makes tight joints when the sides are closed up, as above stated.

The lower inner edges of the end pieces are beveled, as shown at *p*, to avoid the cutting action which more angular corners would have

on the packing when said edges swing down outside of the packing as the sides close up.

The parts may be fastened to close the joint between the end pieces tightly by various forms of fastening devices; but what I prefer as a simple means of quickly fastening and unfastening them and of drawing the meeting edges tight consists of the hook-studs *l*, projecting outward from one part of each end, hooks *m* for engaging said studs, and the elbow-lever *s* for drawing the hooks tight, said elbow-lever pivoted to the other part of the end at *n* for a fulcrum, and at the end of a short arm of the elbow pivoted to the hook by the joint *o*, ranging in line with fulcrum *n* and stud *l*, said fulcrum being between the stud and pivot, so as to draw the pivot slightly past said line and lock the fastening in a simple and efficient manner, lever *s* coming to rest on stud *q*, and be as readily unlocked when the box is to be opened. This device also effects a powerful opening thrust on the sides of the box to detach them from the enclosed material when the box is to be opened. The several parts of the box will be lined with suitable metal or composition plates, which will be cemented to the said part of the box to avoid the use of screws or other like fastenings. It will be seen that in this contrivance I have provided a very simple box, the parts of which may be readily separated for convenience in removing large masses of crystallized material and may be as readily restored and closed tightly in the joints, as especially useful or required for "framing" in the manufacture of cold or other soaps.

I am aware that various forms and contrivances of crystallizing-boxes have been provided for the like purpose of opening to remove the contents, and I do not claim such boxes generally; but in the construction of the sides and end portions, packings, and fastening and unfastening clamps, which I have above described and shown in the drawings, I have represented simpler and cheaper construction and more readily operative devices than any prior apparatus of the kind known to me, and I only claim the improvements specified.

I claim—

1. The combination, in a crystallizing or setting box, of a bottom plate, end plates parted

- vertically and the parts respectively attached to the side plates to be opened and closed together with them, the compressible joint-packing at the bottom of said side and end plates 5 and in the meeting edges of the end plates, and the clamp-fastenings to connect and secure the ends and sides, said packings being compressed in the said joints when the parts are connected, substantially as described.
- 10 2. The combination, in a crystallizing or setting box, of the rabbeted and packed bottom plate, the sides having the parted ends attached to them, the tightening-joints connecting the sides and bottom, and the self-locking 15 hook and lever-clamps fastening the ends and through them also securing the sides, said ends having the packing in the meeting joints, substantially as described.
- 20 3. The combination, in a crystallizing or setting box, of the rabbeted and packed bottom plate, the sides having the parted ends attached to them, the tightening-joints connecting the sides and bottom, consisting of the horn-cleats on the sides and the socket-clips 25 on the bottom plate, and the hook and lever clamps fastening the ends and through them securing the sides, said ends having the packing in the meeting joints, substantially as described.
- 30 4. The combination, in a crystallizing or setting box, of the rabbeted and packed bottom plate, the sides having the parted ends attached to them, the tightening-joints connect-
- ing the sides and bottom, and the clamps fastening the ends and through them securing 35 the sides, said clamps consisting of the catch-hook, stud, and elbow-lever, said lever having its fulcrum-pivot intermediate the stud and the pivot connecting the lever and hook and substantially in line therewith, as herein set 40 forth.
5. The combination, in a crystallizing or setting box, of the sides and parted ends respectively fastened together and jointed to the bottom, and the catch-hook, stud, and elbow-lever 45 fastening-clamps, said clamps adapted to thrust the sides apart when the clamps are released for opening the box, substantially as described.
6. The combination, in a crystallizing or setting 50 box, of the sides and parted ends respectively fastened together and jointed to the bottom, the catch-hook, stud, and elbow-lever fastening-clamps, and the stop-stud for the elbow-lever, said lever having its fulcrum-pivot 55 intermediate to the pivot connecting the lever and hook, and the stud on which the hook catches, substantially as described.
- In testimony that I claim the foregoing I have hereunto set my hand in the presence 60 of two witnesses.

FREELING W. ARVINE.

Witnesses:

W. J. MORGAN,  
W. B. EARLL.