

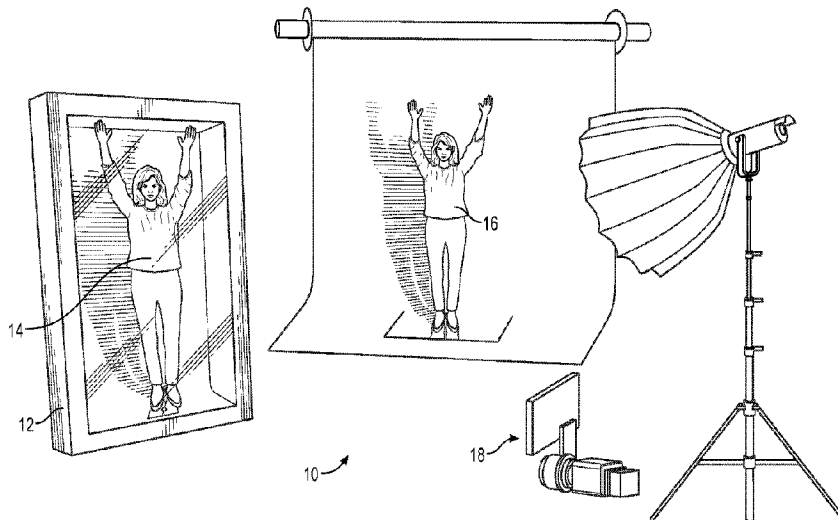

(86) Date de dépôt PCT/PCT Filing Date: 2020/12/04  
 (87) Date publication PCT/PCT Publication Date: 2021/06/10  
 (45) Date de délivrance/Issue Date: 2023/02/28  
 (85) Entrée phase nationale/National Entry: 2021/12/31  
 (86) N° demande PCT/PCT Application No.: US 2020/063423  
 (87) N° publication PCT/PCT Publication No.: 2021/113719  
 (30) Priorité/Priority: 2019/12/06 (US62/944,546)

(51) Cl.Int./Int.Cl. *G03H 1/04* (2006.01),  
*G03H 1/26* (2006.01), *G09F 13/08* (2006.01)  
 (72) Inventeur/Inventor:  
NUSSBAUM, DAVID, US  
 (73) Propriétaire/Owner:  
PROTO, INC., US  
 (74) Agent: RIDOUT & MAYBEE LLP

(54) Titre : DISPOSITIF D’AFFICHAGE HOLOGRAPHIQUE ET PROCEDE D’UTILISATION  
 (54) Title: HOLOGRAPHIC DISPLAY DEVICE AND METHOD OF USE



(57) **Abrégé/Abstract:**

A holographic display device for presenting a hologram-like image and a method of use are disclosed. The holographic display device includes a box-like structure, a translucent panel, and light panels extending the entire length of the box-like structure. The light panels position between the box-like structure and the translucent panel. The holographic display device includes a transparent monitor connecting the box-like structure at its front end. The transparent monitor receives and displays an image. The light panels illuminate light and the translucent panel diffuses, blends, and evenly distributes the light in the interior. Transmitted shadowing to the monitor provides a realistic appearance. A unique image capturing system for capturing the image to be displayed on the transparent monitor is also disclosed. The image capturing system transmits the image to the holographic display device in real-time or as a pre-recorded image using wired or wireless protocols.



**WO 2021/113719 A1** 

**(84) Designated States** (*unless otherwise indicated, for every kind of regional protection available*): ARIPO (BW, GH, GM, KE, LR, LS, MW, MZ, NA, RW, SD, SL, ST, SZ, TZ, UG, ZM, ZW), Eurasian (AM, AZ, BY, KG, KZ, RU, TJ, TM), European (AL, AT, BE, BG, CH, CY, CZ, DE, DK, EE, ES, FI, FR, GB, GR, HR, HU, IE, IS, IT, LT, LU, LV, MC, MK, MT, NL, NO, PL, PT, RO, RS, SE, SI, SK, SM, TR), OAPI (BF, BJ, CF, CG, CI, CM, GA, GN, GQ, GW, KM, ML, MR, NE, SN, TD, TG).

**Declarations under Rule 4.17:**

- *as to the applicant's entitlement to claim the priority of the earlier application (Rule 4.17(iii))*
- *of inventorship (Rule 4.17(iv))*

**Published:**

- *with international search report (Art. 21(3))*

**IN THE RECEIVING OF THE UNITED STATES**

**HOLOGRAPHIC DISPLAY DEVICE AND METHOD OF USE**

Inventor: David Nussbaum

5

**CROSS-REFERENCE TO RELATED APPLICATIONS**

[0001] This application claims the benefit of priority from U.S. Provisional Application No. 62/944,546, filed December 6, 2019, entitled “HOLOGRAPHIC DISPLAY DEVICE AND METHOD OF USE.”

10

**FIELD OF THE DISCLOSURE**

[0002] The present invention relates to a holographic display device, and more specifically, to a holographic display device and methods of use for displaying a hologram-like image on a transparent monitor positioned at the front end of a three-dimensional interior lit display box.

15

**BACKGROUND OF THE INVENTION**

[0003] Holographic displays and holographic-like displays are used to present a realistic looking three-dimensional (3D) object on a two-dimensional (2D) surface. The use of a transparent liquid crystal display (LCD) screens within a boxlike structure is one way to make a realistic 3D image appear where the LCD screen is mounted. However, since an LED monitor can only present 2D images, and the image on the screen appears the same, regardless of which angle the image is viewed from (unlike spatial light modulators, where the image appears different from different angles).

20

[0004] Several methods utilizing the above-discussed techniques have been disclosed in the past.

25

One such example is disclosed in a United States granted patent No. 9,581,962, entitled “Methods and systems for generating and using simulated 3D images” (the “’962 Patent”). The ‘962 Patent discloses a three-dimensional image simulation device for managing a live event comprising an image capturing device for capturing live captured data corresponding to a presenter and generating, in real-time, hologram data based on the live captured data. An output interface for broadcasting the hologram data in real-time to at least one additional location containing an audience, wherein the hologram data is used to create a hologram of the presenter

30

at least one additional location based on an apparent parallax effect in a simulated three-dimensional display device, the hologram creating a three-dimensional illusion for the audience regarding the actual presence of the presenter at the at least one additional location.

Furthermore, an input interface for receiving audience data from at least one additional location regarding the interaction between the hologram and the audience and a display device for  
5 displaying images based on audience data to the presenter.

[0005] Another example is disclosed in a South Korean Patent Publication No. 20170055073, entitled “Blended Display Apparatus” (the “’073 Publication”). The ‘073 Publication relates to a combination-type display device capable of displaying a combination-type display content in a  
10 display-advertisement content by using three-dimensional information wherein a hologram and an OLED transparent display are combined. The combination-type display device includes: a hologram front surface unit receiving an image for the hologram and an image for the display, forming the image for the hologram and thereafter reflecting the image to a front side, adjusting the brightness of a lamp or turning on/off the lamp according to lamp control signals; a display  
15 case unit having the hologram front surface unit on a front surface to enable a display subject to be shown in the hologram front surface unit through the front surface; and a control device unit storing the combination-type content wherein the image for the hologram and the image for the display are combined, separating the content into the image for the hologram and the image for the display and thereafter inputting the images to the hologram front surface unit, and generating  
20 the lamp control signals and thereafter inputting the lamp control signals to the hologram front surface unit.

[0006] Another example is disclosed in a PCT Publication No. 2018154458, entitled “Hologram Karaoke Jukebox” (the “’458 Publication”). The ‘458 Publication discloses a system that  
25 generates a holographic image of the celebrity who is also performing the song right next to the karaoke singer. The system enables remote/local audiences to perceive that the karaoke singer is performing a song next to and with the celebrity. The system can enable audience users to be able to access live/recorded events at the local location or anywhere around the world using smartphones, tablets, PCs, and TV monitors to watch the holographic performance and/or event. Processes can allow for local and worldwide viewing of local and worldwide events/contests to  
30 be held and where anyone can save the video and send it to a friend and/or vote for their favourite karaoke singer who may be in a contest.

[0007] Yet another example is disclosed in a Chinese granted patent No. 208301373, entitled “Holographic show cupboard” (the “’373 Patent”). The ‘373 Patent provides a holographic show cupboard, having the cabinet body, holographic projector, and holographically projected screen for projecting a holographic image.

5 [0008] Yet another example is disclosed in a Chinese granted patent No. 209248795, entitled “AR Interactive Holographic Whiteboard” (the “’795 Patent”). The ‘795 Patent discloses an AR interactive holographic whiteboard which comprises a shell, an AR transparent liquid crystal display screen, a holographic imaging reflector plate, and a 65-inch display screen. A display screen mounting part is arranged on the shell; mounting grooves are formed in the two adjacent  
10 end faces, corresponding to the display screen mounting part, of the shell. The AR transparent liquid crystal display screen is mounted in the mounting groove in one end surface; the 65-inch display screen is installed in the installation groove in the other end face, the holographic imaging reflector plate is obliquely arranged in the display screen installation part, the included angle between the holographic imaging reflector plate and the 65-inch display screen is 45  
15 degrees, and the included angle between the AR transparent liquid crystal display screen and the 65-inch display screen ranges from 15 degrees to 75 degrees. The interactive mode of a traditional electronic whiteboard is broken through, AR augmented reality and holographic imaging technology are combined for holding, and the visual experience of a user is improved.

[0009] The above disclosures present a realistic 3D like the image on a two-dimensional surface.  
20 Still, there remains a continuing need for improved techniques to make transparent LCD holographic display devices look more realistic.

### **BRIEF SUMMARY OF THE PRESENT INVENTION**

[0010] The present invention provides a new and improved holographic display device for  
25 displaying a hologram-like image on a transparent liquid crystal display (LCD) monitor/screen. The following presents a summary of exemplary embodiments of the present invention in order to provide a basic understanding of some aspects described herein. This summary is not an extensive overview of the claimed subject matter. It is intended to neither identify key nor

30

critical elements of the claimed subject matter nor delineate the scope of the subject innovation. Its sole purpose is to present some concepts of the claimed subject matter.

**[0011]** One element of the holographic display device provides a hologram-like image effect within a holographic display device when the right content i.e., image is presented on a transparent monitor. The holographic display device includes a box-like structure, a translucent panel i.e., diffuser, and light panels extending the entire length, or substantially the entire length, of the box-like structure. In one implementation, the light panels include light-emitting diode (LED) strips. The light panels position between the box-like structure and the translucent panel. In one preferred implementation, the light panels are positioned at the top, sides, and rear of the translucent panel. The holographic display device includes a transparent monitor connecting the box-like structure. The transparent monitor and the translucent panel form an interior for the box-like structure. In other words, the transparent monitor and the translucent panel form a box-like structure with the transparent monitor at its front. The translucent panel provides a translucent material made of acrylic or other composition capable of diffusing light in the interior.

**[0012]** In one aspect of the present invention, the transparent monitor receives and displays an image. The light panels illuminate light and the translucent panel diffuses, blends, and evenly distributes the light in the interior. The image displayed on the transparent monitor appears as a hologram-like image with a well-lit interior at the backdrop. In one example, the translucent panel encompasses soft and curved edges to create a seamless or continuous look making the interior a more realistic background without any seam or line or edge. This allows providing a much more realistic hologram effect when the image is displayed on the transparent monitor.

**[0013]** In another aspect of the present invention, the invention provides a monitor frame that encompasses the transparent monitor. The monitor frame recesses to control the viewing angle of the transparent monitor and helps to enhance the hologram effect of the image displayed on the transparent monitor.

**[0014]** In one aspect of the present invention, the invention provides the image capturing system for capturing the image to be displayed on the transparent monitor. The image capturing system includes a sheet made used commonly for cyclorama (cyc) materials (which may be a flexible fabric, paper, or even solid structures such as a wall). A platform is placed on the sheet which a subject e.g., a human being stands. The platform acts as a reflective floor and reflects the

down/bottom portion of the subject. The image capturing system includes a light box to project light onto the subject. The light creates a shadow on the sheet and reflection from the platform of the subject. A camera captures the image of the subject, the shadow, and the reflection. Subsequently, the image capturing system transmits the image (with subject, shadow, and reflection) to the holographic display device. The holographic display device displays the image on the transparent monitor. The image displayed or presented on the transparent monitor appears as a hologram-like image with a well-lit interior creating maximum depth, dimension, and realistic effect for the image displayed on the transparent monitor.

[0015] In one aspect of the present invention, the image capturing system transmits the image to a data storage device, such as a universal serial bus (USB) stick, for example. The data storage device plugs to the holographic display device for presenting the image on the transparent monitor. In another aspect of the present invention, the image capturing system transmits the image to an electronic device, such as a mobile phone, for example. The electronic device transmits the image to the holographic display device for presenting the image on the transparent monitor. Alternatively, the image capturing system transmits the image in real-time using wired or wireless protocols.

[0016] In one aspect of the present invention, the holographic display device includes speakers connected to the box-like structure. The speakers output audio signals when the image is displayed on the transparent monitor to present an interactive experience. The holographic display device further includes a camera (still or video camera) mounted at the top. The camera helps to capture its field of view (audiences and their movements) and sends back the feed to the image capturing system for live interaction with the subject. This allows the subject to have a telepresence effect. In one example, the image capturing system provides a feed reference monitor to show the images or video captured by the camera mounted at the holographic display device to enhance the realistic interactive experience for the subject and audiences.

[0017] Additional features and advantages of the invention hereof will become more apparent in light of the following detailed description of selected embodiments, as illustrated in the accompanying Figures. As will be realised, the invention disclosed is capable of modifications in various respects, all without departing from the scope of the invention. Accordingly, the drawings and the description are to be regarded as illustrative in nature.

**BRIEF DESCRIPTION OF THE DRAWINGS**

[0018] The present invention will now be described in detail with reference to the drawings, which are provided as illustrative examples of the invention as to enable those skilled in the art to practice the invention. It will be noted that throughout the appended drawings, like features are identified by like reference numerals. Notably, the Figures and examples are not meant to  
5 limit the scope of the present invention to a single embodiment, but other embodiments are possible by way of interchange of some or all of the described or illustrated elements and, further, wherein:

[0019] **FIG. 1** is an environment of a holographic display device presenting a hologram-like  
10 image of a subject captured using an image capturing system, in accordance with one exemplary embodiment of the present invention;

[0020] **FIG. 2** and **FIG. 3** depict a perspective view and an exploded view, respectively of the holographic display device, in accordance with one embodiment of the present invention;

[0021] **FIG. 4** shows a feature of light panels connecting via plug connectors;

15 [0022] **FIG. 5** shows a side view of a translucent panel having curvature or curved edges;

[0023] **FIG. 6** shows a feature of a monitor frame surrounding a transparent monitor;

[0024] **FIG. 7** shows a feature of a deck connecting a box-like structure of the holographic display device at the bottom;

20 [0025] **FIG. 8** is a block diagram of electrical/electronic components of the holographic display device;

[0026] **FIG. 9** and **FIG. 10** show electronic components of the holographic display device;

[0027] **FIG. 11** and **FIG. 12** show a perspective and a side view, respectively of a set-up of the image capturing system for capturing an image or video of the subject to present on the transparent monitor of the holographic display device;

25 [0028] **FIG. 13** shows an exemplary set-up of the image capturing system having a camera, a reference monitor, a feed reference monitor, and a light box, in accordance with one exemplary embodiment of the present invention;

[0029] **FIG. 14** shows the hologram-like image presented on the transparent monitor; and,

30 [0030] **FIG. 15, FIG. 16, FIG. 17,** and **FIG. 18** show a holographic display device having a triangular shape/configuration, in accordance with another embodiment of the present invention for placement of the holographic display device in a corner of a room.

**DETAILED DESCRIPTION OF EMBODIMENTS**

[0031] The invention now will be described more fully hereinafter with reference to the accompanying drawings, in which embodiments of the invention are shown. This invention may  
5 however be embodied in many different forms and should not be construed as limited to the embodiments set forth herein. Rather, these embodiments are provided so that this disclosure will be thorough and complete, and will fully convey the scope of the invention to those skilled in the art.

[0032] It will be understood that when an element is referred to as being “on” another element, it  
10 can be directly on the other element or intervening elements may be present therebetween. As used herein, the term “and/or” includes any combinations of one or more of the associated listed items.

[0033] It will be understood that, although the terms first, second, third, etc. may be used herein to describe various elements, components, regions, layers, and/or sections, these elements,  
15 components, regions, layers, and/or sections should not be limited by these terms. These terms are only used to distinguish one element, component, region, layer, and/or section from another element, component, region, layer, and/or section.

[0034] It will be understood that the elements, components, regions, layers, and sections depicted in the figures are not necessarily drawn to scale.

[0035] The terminology used herein is for the purpose of describing particular embodiments  
20 only, and is not intended to be limiting of the invention. As used herein, the singular forms “a,” “an,” and “the” are intended to include the plural forms as well, unless the context clearly indicates otherwise. It will be further understood that the terms “comprises” and/or “comprising,” or “includes” and/or “including” when used in this specification, specify the  
25 presence of stated features, regions, integers, steps, operations, elements, and/or components, but do not preclude the presence or addition of one or more other features, regions, integers, steps, operations, elements, components, and/or groups thereof.

[0036] Furthermore, relative terms, such as “lower” or “bottom,” “upper” or “top,” “left” or  
30 “right,” “above” or “below,” “front” or “rear,” may be used herein to describe one element’s relationship to another element as illustrated in the Figures. It will be understood that relative

terms are intended to encompass different orientations of the device in addition to the orientation depicted in the Figures.

[0037] Unless otherwise defined, all terms used herein have the same meaning as commonly understood by one of ordinary skill in the art to which this invention belongs. It will be further understood that terms, such as those defined in commonly used dictionaries, should be interpreted as having a meaning that is consistent with their meaning in the context of the relevant art and the present disclosure, and will not be interpreted in an idealised or overly formal sense unless expressly so defined herein.

[0038] Exemplary embodiments of the present invention are described herein with reference to idealised embodiments of the present invention. As such, variations from the shapes of the illustrations as a result, for example, of manufacturing techniques and/or tolerances, are to be expected. Thus, embodiments of the present invention should not be construed as limited to the particular shapes of regions illustrated herein but are to include deviations in shapes that result, for example, from manufacturing. The invention illustratively disclosed herein suitably may be practiced in the absence of any elements that are not specifically disclosed herein.

[0039] Turning to the Figures, **Fig. 1** shows environment **10** in which holographic display device **12** displays or presents hologram-like image **14** of subject **16** such as a human being captured using image capturing system **18**, in accordance with one exemplary embodiment of the present invention.

[0040] **Fig. 2** and **Fig. 3** depict a perspective view and an exploded view, respectively of holographic display device **12**, in accordance with one embodiment of the present invention. Holographic display device **12** provides container or box or housing or box-like structure **20**. In one example, box **20** comes in a rectangular shape/configuration. However, a person skilled in the art appreciates that box **20** may come in other shapes say square shape, for example. Box **20** is big enough e.g., 6 to 7-foot-tall, 3-foot-wide, and 1 to 2-foot-deep (i.e., depth) to showcase or present a hologram-like image of a full-sized adult. However, a person skilled in the art appreciates that box **20** may come in different shapes and sizes.

[0041] Box **20** presents bottom frame **22**, first side frame **24**, second side frame **26**, top frame **28**, and rear frame **30**. Each of bottom frame **22**, first side frame **24**, second side frame **26**, and top frame **28** provides an L-shaped frame made of metal, hard plastic, or any other suitable material. First side frame **24** indicates a left side frame and second side frame **26** indicates a right-side

frame. Here, rear frame **30** includes two door frames i.e., first door frame **32** and second door frame **34**. First door frame **32** and second door frame **34** operate similar to two-door mechanisms known in the art. First door frame **32** and second door frame **34** facilitate access to electrical/electronic components. Bottom frame **22**, first side frame **24**, second side frame **26**, top frame **28** and rear frame **30** connect with the help of fasteners or welding or any other known mechanism. As specified above, box **20** comes in a rectangular configuration. In one example, box **20** is portable and stands vertically. In one example, box **20** rests on a trolley or metal caddy (not shown) with wheels and casters. The metal caddy allows box **20** to transport easily from one location to another.

**[0042]** Box **20** encompasses light panels **36**. Light panels **36** include light-emitting diode (LED) panels. Light panels **36** extend approximately the entire length of box **20**. In one implementation, light panels **36** includes side light panels **38**, top light panel **40**, and rear light panel **42**. Here, side light panels **38** connect in proximity to first side frame **24**, second side frame **26**. Top light panel **40** connects in proximity to top frame **28**. Rear light panel **42** connects in proximity to rear frame **30**. **Fig. 4** shows a feature of side light panels **38** and top light panel **40** connecting via plug connectors **43**. Each of light panels **36** provides approximately eleven LED strips **44** spaced apart at about 1 ¼” from one another. Each LED strip **44** provides a series of surface mounted light-emitting diodes (LEDs) **46**. A person skilled in the art appreciates each of the light panels **36** may have more or less than 11 LED strips **44** spaced apart at an equal or varied distance from one another. The number of LED strips **44** and their spacing depends on the size of box **20** and the amount of light needed to illuminate the interior of box **20**. In one example, LEDs **46** provide 8000 colour temperature at 60 lumens per foot to brightly lit the interior of box **20**.

**[0043]** Further, box **20** provides translucent panel **48**. Translucent panel **48** provides a translucent material made of acrylic or other composition capable of diffusing the light within box **20**. In other words, translucent panel **48** provides an acrylic layer and acts as a light translucent panel. Here, light panels **36** position between box **20** (i.e., outer casing) and translucent panel **48**. In one implementation, translucent panel **48** has a milky white colour and extends over the entire length of box **20** and/or light panels **36**. A person skilled in the art understands that colour and dimensions of the translucent panel may vary depending on the need. Translucent panel **48** includes bottom translucent panel **50**, side translucent panels **52**, rear

translucent panel **54**, and top translucent panel **56**. In operation, translucent panel **48** helps to diffuse, blend, and evenly distribute the high luminosity produced by light panels **36**.

[0044] **Fig. 3** shows an exemplary translucent panel **48**, in accordance with one embodiment of the present invention. Here, bottom translucent panel **50** and top translucent panel **56** position  
5 parallelly to each other, and perpendicularly to side translucent panels **52**. Rear translucent panel **54** positions perpendicularly to side translucent panels **52**, and bottom translucent panel **50** and top translucent panel **56**. In one example, edges of bottom translucent panel **50**, side translucent panels **52**, rear translucent panel **54** and top translucent panel **56** connect at 90 degrees (right angle having visible seams). In another example, edges of bottom translucent panel **50**, side  
10 translucent panels **52**, rear translucent panel **54**, and top translucent panel **56** have a curvature or inclination **C** say between 5 to 30 degrees (radius). A person skilled in the art appreciates that edges of bottom translucent panel **50**, side translucent panels **52**, rear translucent panel **54**, and top translucent panel **56** may have curvature **C** more or less than 5 to 30 degrees and such implementation falls with the scope of the presently disclosed holographic display device **12**.

15 **Fig. 5** shows a side of translucent panel **48** bottom translucent panel **50**, rear translucent panel **54**, and top translucent panel **56** provided at 4" radius, in accordance with one exemplary embodiment of the present invention. Curvature **C** at the edges of translucent panel **48** provides a more realistic appearance of subject **16** moving forward and back within box **20** when hologram-like image **14** is displayed on transparent monitor **58**. In the present invention,  
20 transparent monitor **58** indicates a display or screen or display screen, or touch screen display, etc and connecting box **20**. Transparent monitor **58** mounts to box **20** at its front end, as shown in **Fig. 2**. Transparent monitor **58** includes a liquid crystal display (LCD) screen known in the art. Further, transparent monitor **58** includes display devices such as LCD, plasma, LED, OLED, and the like without departing from the scope of the present invention. In one example,  
25 transparent monitor **58** presents a flat panel display that is parallel to rear frame **30** or rear translucent panel **54**. In another example, transparent monitor **58** presents a curved panel display that extends outward or inward from box **20** (i.e., rear frame **30** or rear translucent panel **54**).

[0045] In one implementation, transparent monitor **58** encompasses in monitor frame or bezel **60**. In other words, monitor frame **60** surrounds or mounts around transparent monitor **58**. In  
30 one implementation, transparent monitor **58** has 4K resolution for displaying clear hologram-like image **14** of subject **16**. Further, transparent monitor **58** measures 86 inches diagonally. A

person skilled in the art understands that transparent monitor **58** measures more or less than 86” inches and such measurement depend on the need. In one example, transparent monitor **58** mounts to monitor frame **60** via monitor brackets **62**. Further, box **20** includes L-shaped brackets **64**. **Figs. 3** and **6** show L-shaped brackets **64** connecting monitor frame **60** to box **20** and/or light panels **36** via elongated connectors **66**. In addition, monitor frame **60** presents speaker brackets **68** for connecting speakers or audio outputs **70**. Speaker brackets **68** present an L-shaped bracket **72** to connect speakers **70**. In one preferred embodiment, speakers **70** mount at approximately 5 feet from the ground. Mounting speakers **70** at a suitable height allows to present voice of subject **16** in a realistic manner when hologram-like image **14** of subject **16** is displayed on transparent monitor **58**. As presented above, first side frame **24** and second side frame **26** include an L-shaped frame. Here, each of first side frame **24** and second side frame **26** includes speaker receiving section **74** for aligning with speakers **70**.

[0046] In one embodiment, transparent monitor **58** includes panel **76** for connecting electrical/electronic components via cables **78** to draw power and input to display hologram-like image **14** on transparent monitor **58**.

[0047] Further, box **20** encompasses deck **80** placed between bottom frame **22** and bottom translucent panel **50**. In one implementation, deck **80** presents power supply mounting plate **81** for supplying power to Light panels **36** via plug connectors **43**. **Figs. 3, 6, and 7** show the feature of deck **80** mounted to bottom frame **22**.

[0048] In addition, box **20** includes first camera **82** at top frame **28**. Top frame **28** encompasses camera mounting plate **83** for placing first camera **82**. The present invention shows mounting first camera **82** at top frame **28**, however, a person skilled in the art appreciates that first camera **82** may be placed at any other position facing the front portion of box **20**. Providing first camera **82** at top frame **28** allows to capture a field of view of box **20**. For example, when holographic display device **12** is used for interacting with the audience, first camera **82** captures actions or movements of the audience in front of box **20** and allows to transmit the data for providing the telepresence effect. Further, box **20** includes fans **84** that mount to first side frame **24** and second side frame **26** via fan brackets **86**. In one example, first side frame **24** and second side frame **26** include fan receiving sections **88** that align with fans **84**. Fans **84** help to protect holographic display device **12** and keep exterior cool allowing human beings to touch from outside i.e., box **20** when holographic display device **12** is in use. Fans **84** blowout hot air

generated by light panels **36** through fan receiving sections **88** and/or vents **90** (**Fig. 10**) placed at the top and bottom of box **20**.

[0049] In accordance with the present invention, translucent panel **48** i.e., bottom translucent panel **50**, side translucent panels **52**, rear translucent panel **54** and top translucent panel **56** together with transparent monitor **58** at the front provides an interior or opening or hollow portion **92** within box **20**. Here, the positioning of light panels **36** at the top, side, and rear enable interior **92** to be fully lit. In use, translucent panel **48** (together with light panels **36**) covering the rear, sides, top and bottom and transparent monitor **58** covering the front end form a three-dimensional (3D) interior lit display box.

[0050] **Fig. 8** shows a block diagram of holographic display device **12** consisting of electric/electronic components. Holographic display device **12** includes processor **100** for controlling operations of holographic display device **12**. In one example, processor **110** includes central processing unit (CPU) **102**, read-only memory (ROM) **104**, random-access memory (RAM) **106**, and graphic processing unit (GPU) **108** connected via a bus (not shown). CPU **102** accesses memory **110** that stores program instructions and data for controlling holographic display device **12**. Memory **110** implements as a hard disk, a non-volatile memory, or a volatile memory. CPU **102** also performs various operations by using various types of programs, contents, data, and the like stored in memory **110**. ROM **106** stores a command set, and the like for booting holographic display device **12**. Upon booting, GPU **108** generates a screen that includes various objects such as an icon, an image, a text, and the like.

[0051] Holographic display device **12** includes broadcast receiver **112**, first interface **114**, second interface **116**, signal separator **118**, an audio/video (A/V) processor **120**, an image signal generator **122**, communication interface or transceiver **124**, an input interface **126**, light controller **128**, volume controller **130** and switch **132**. In addition, processor **102** communicatively connects to transparent monitor **58**, speakers **70**, and first camera **82**.

[0052] In one example, broadcast receiver **112** receives a broadcasting signal in a wired or wireless manner from a broadcasting station or a satellite and demodulates the received broadcasting signal. Broadcast receiver **112** receives a transmission stream via an antenna or a cable, demodulates it, and output a digital transmission stream signal. Alternatively, processor **102** receives an image and/or audio and video signal via first interface **114** and/or second interface **116**. Here, first interface **114** includes a universal serial bus (USB) interface. Second

interface **116** interface a high definition multimedia interface (HDMI) interface. A person skilled in the art appreciates that first interface **114** and second interface **116** may include any other interfaces that are known in the art.

5 [0053] Signal separator **118** divides a transmission stream signal provided from one of broadcast receiver **112**, first interface **114**, and second interface **116** into an image signal, an audio signal, and an additional information signal. Further, signal separator **118** transmits the image signal and the audio signal to A/V processor **120**. A/V processor **120** performs signal processing, such as video decoding, video scaling, and audio decoding, with respect to the video signal and the audio signal that is given as input from broadcast receiver **112**, first interface **114**, and second  
10 interface **116**. In addition, A/V processor **120** outputs the image signal to image signal provider **122** and outputs the audio signal to speaker **70**.

[0054] Image signal provider **122** provides an image signal corresponding to an image received in the broadcast signal to transparent monitor **58**. Transparent monitor **58** displays various information provided from image signal provider **160**.

15 [0055] Transceiver **124** communicates with various kinds of external devices in various communication methods. Transceiver **124** includes a Wi-Fi chip, a cellular chip (SIM card), and/or a Bluetooth chip. In one exemplary implementation, transceiver **124** includes a USB port (similar to first interface **114**) to which a USB connector is connected, various external input ports for connecting various external terminals such as a LAN, and a Digital Multimedia  
20 Broadcasting (DMB) chip that receives and processes a DMB signal.

[0056] Input interface **126** includes a touch screen, touch pad, key button, keypad, a remote controller, and the like to allow a user manipulation of transparent monitor **58** and/or holographic display device **12** itself.

[0057] Light controller **128** includes a software or hardware toggle to control illumination or  
25 dimming of LED strips **44**. Volume controller **130** includes software or hardware toggle/button to control volume outputted via speakers **70**. Switch **132** includes software or hardware toggle/button for switching ON/OFF LED strips **44**, transparent monitor **58**, or any other component including holographic display device **12**. **Figs. 9** and **Fig. 10** show an exemplary first interface **114**, second interface **116**, light controller **128**, volume controller **130**, and switch  
30 **132** positioned at the bottom of box **20**.

[0058] Figs. 11 and 12 show a perspective and side view of a set-up of image capturing system 18 for capturing or recording an image or video of subject 16 such as a human being to present or display hologram-like image 14 of subject 16 at transparent monitor 58 (e.g., Fig. 1), in accordance with one exemplary embodiment of the present invention. Image capturing system 5 18 includes sheet or sheet roll 140 mounted to frame or pole 142. In other words, sheet 140 suspends from frame 142. Sheet 140 provides a material made of cyclorama (cyc) material. Here, sheet 140 acts as a white or natural seamless flat muslin panel to help create a scene for subject 16 to record image or video. In the current embodiment, sheet 140 suspends from frame 142 and seamlessly extends over the surface such as ground creating curvature 144. Curvature 10 144 provides a smooth or continuous effect for sheet 140. Upon the sheet 140 presents platform or stage 146 upon which subject 16 positions/stands to record image or video. Platform 146 presents a reflective floor made of clear plexiglass or acrylic material having an area of approximately 2' x 4', for example. As platform 146 provides a reflective floor, the subject's image/shape presents reflection 160 of the bottom portion of subject 16 (Fig. 11). In one 15 example, consider subject 16 is a human being. Here, the person stands on platform 146 for recording his image or video for presenting it as hologram-like image 14 on transparent monitor 58. In another example, consider subject 16 as a physical product say a shoe. Here, the shoe rests on platform 146 for recording its image or video (covering shape) for presenting it as hologram-like image 14 on transparent monitor 58.

20 [0059] Image capturing system 18 presents second camera or image capturing sensor 148 for capturing still images or video of subject 16. Second camera 148 encompasses a suitable lens set up to create a vertical or horizontal image to capture every detail image of subject 16. Second camera 148 is set up to capture images in vertical or horizontal frames depending on the orientation of hologram-like image 14 that needs to be displayed on transparent monitor 58. 25 Second camera 148 positions at approximately 2 feet high from the surface i.e., ground to capture subject 16. Second camera 148 adjusts to avoid hologram-like image 14 appearing to float or leaning backward when displayed on transparent monitor 58. In one exemplary embodiment, image capturing system 18 provides a sound recorder (not shown) for recording voice or sounds made by subject 16 while capturing a video. This helps to record video and 30 audio simultaneously and transmit to holographic display device 12 for playing video via transparent monitor 58 and audio via speakers 70. Image capturing system 18 presents reference

monitor **150** configured to display still image or video captured by second camera **148** in real-time. For example, consider subject **16** is a human being presenting a lecture. Here, second camera **148** captures his actions or movements and transmits signals to reference monitor **150** for displaying his actions in real-time. In other words, reference monitor **150** shows subject **16** where it or he is in relation to a frame. This helps him to correct or adjust his posture.

5 Additionally, image capturing system **18** presents feed reference monitor **152** configured to display images or video (i.e., its field of view) captured by first camera **82** of holographic display device **12**. Considering the above example, subject **16** i.e., the presenter gets to see on feed reference monitor **152** how audiences are reacting to his lecture/actions/movements being  
10 displayed as hologram-like image **14** on transparent monitor **58**. In other words, feed reference monitor **152** acts as a display screen of return feed from holographic display device **12** to provide a telepresence arrangement. In one example, image capturing system **18** includes a speaker (not shown) to play the audio of audiences to make it more interactive between subject **16** and audiences. Additionally, image capturing system **18** provides light box **154** for providing light  
15 **156** on subject **16** while recoding his still image or video by second camera **148**. **Fig. 13** shows an exemplary set-up of second camera **148**, reference monitor **150**, feed reference monitor **152**, and light box **154**, in accordance with one embodiment of the present invention.

[0060] In order to record still images or video of subject **16** by second camera **148** and present/display hologram-like image **14** on transparent monitor **58**, at first, light box **154** projects  
20 light **156** onto subject **16**, as shown on **Fig. 11**. In one implementation, subject **16** positions closer to sheet **140** and stands/places on platform **146**. For example, if subject **16** is a human being, then subject **16** faces his back close to sheet **140** and stands on platform **146**. Light **156** creates distant shadow **158** of subject **16** on sheet **140** and illuminates reflection **160** of subject **16** on platform **146**. This helps to create shadow **158** of subject **16** behind them and helps to tie subject **16** to shadow **158**. Similarly, platform **146** creates reflection **160** of subject **16** and helps to tie subject **16** to reflection **160**. Second camera **148** captures image/video and/or sound of subject **16** together with shadow **158** and reflection **160**. After capturing image data i.e.,  
25 (image/video having shadow **158** and reflection **160** and sound) of subject **16**, second camera **148** transmits the image data to holographic display device **12**. A person skilled in the art appreciates that second camera **148** transmits the image data using wired or wireless protocols to  
30 holographic display device **12** via one of broadcast receiver **112**, first interface **114**, second

interface **116**, and communication interface **124**. Signal separator **118** divides the image data into an image signal, an audio signal, and an additional information signal. Further, signal separator **118** transmits the image signal and the audio signal to A/V processor **120**. A/V processor **12** decodes the image signal and outputs the image signal as hologram-like image **14** on transparent monitor **58** with the help of image signal provider **122**. Simultaneously, A/V processor **12** decodes the audio signal and outputs the audio signal via speaker **70**. This ensures that hologram-like image **14** of object **16** gets displayed on transparent monitor **58** and sound recorded using second camera **146** plays out via speaker **70** simultaneously.

[0061] As presented above, the positioning of light panels **36** enable interior **92** to be fully lit from the side, rear, and/or top of box **20**. Further, translucent panel **48** (together with light panels **36**) covering the rear, sides, top and bottom and transparent monitor **58** covering the front end form a three-dimensional (3D) interior lit display box. As such, hologram-like image **14** of object **16** gets displayed on transparent monitor **58**. Further, shadow **158** and reflection **160** of object **16** get displayed as shadow **162** and reflection **164** on transparent monitor **58**. **Fig. 14** shows hologram-like image **14** having shadow **162** and reflection **164** displayed on transparent monitor **58**, in accordance with one exemplary embodiment of the present invention. Light panels **36** produce bright light and translucent panel **48** evenly distributes and blends the light in interior **92**. This creates maximum depth, dimension, and realistic effect for hologram-like image **14** displayed on transparent monitor **58**. Hologram-like image **14** having shadow **162** and reflection **164** create a hologram effect when displayed on transparent monitor **58** with well-lit interior **92** as a backdrop in holographic display device **12**. In other words, hologram-like image **14** having shadow **162** and reflection **164** provide a hologram effect with a more natural and realistic background. Configuring light panels **36** to provide maximum lumens helps to create a much brighter, crisper, and higher resolution hologram-like image. Further, providing translucent panel **48** with curvature **C** help to have curved/sloped/seamless interior **92** at the top and bottom. In other words, bottom translucent panel **50** presents curvature **C** where it connects rear translucent panel **54** and creates a seamless or continuous look making interior **92** more realistic background without any seam or line or edge from bottom translucent panel **50** to rear translucent panel **54**. This allows to provide a much more realistic hologram effect of hologram-like image **14** when displayed on transparent monitor **58**. Here, seamless curvature **C** at the top, bottom, and sides of translucent panel **48** allow hologram-like image **14** to appear more solid as

the naked eye finds no seams or lines on translucent panel **48** (well-lit interior **92**) through hologram-like image **14**. In one example, monitor frame or bezel **60** design allows to push transparent monitor **58** back (i.e., allows transparent monitor **58** to be recessed) by approximately 3" to control viewing angle and enhance the hologram effect of hologram-like image **14** displayed on transparent monitor **58**.

**[0062]** In one implementation, speakers **70** mount at approximately 5 feet from the ground. When hologram-like image or video **14** gets displayed on transparent monitor **58** simultaneously with sound playing via speakers **70**, it enhances the realistic experience. Further, first camera **82** together with other electronic components help to capture motion, facial features and other aspects of objects or human being (audiences) present in front of holographic display device **12** using known techniques. First camera **82** transmits data captured to feed reference monitor **152** of image capturing system **18** to provide telepresence effect.

**[0063]** A person skilled in the art appreciates that image capturing system **18** helps to record image and sound of the object with (white and cyc) sheet **140** as background and/or platform **146** at the bottom. The recorded image gets transmitted in real-time or when needed to holographic display device **12** for displaying hologram-like image **16** on transparent monitor **58**. As such, the recorded image gets transmitted to holographic display device **12** using wired or wireless protocols via a variety of electronic devices such as USB sticks, HDMI ports, cellular data (e.g., using a mobile phone), and so on.

**[0064]** The presently disclosed holographic display device **12** enables to live stream content (images or video with sound) recorded on-site or remotely. As such, holographic display device **12** helps to display pre-recorded content or live stream as the content gets recorded anywhere via the internet, satellite, or fibre optics transmission.

**[0065]** Further, holographic display device **12** allows users to transmit content (image or video and/or sound) and adjust lighting and other features using an application provided in their electronic devices (e.g., mobile phone) or a remote controller. Alternatively, input interface **126** allows the users to adjust settings of transparent monitor **58** and/or any component of holographic display device **12**.

**[0066]** The presently disclosed holographic display device **12** provides an application for use in theatrical, educational, medical, museums, or other live event presentations. Further, the presently disclosed holographic display device **12** provides an application for use in advertising

or other presentations that are intended to promote and/or extol the features and advantages of any product or service being offered for sale. Furthermore, the presently disclosed holographic display device **12** provides an application for use in presenting or displaying a virtual performance (of pre-recorded content) by a performer, even though the performer is no longer  
5 alive.

[0067] The holographic display device **12** comes in a variety of sizes and shapes. For example, holographic display device **12** comes with dimensions 7' x 3' x 2', 7' being height, 3' being width and 2' being depth (thickness) for displaying hologram-like image **14** of a full-sized adult. However, a person skilled in art holographic display device **12** may come in a variety of shapes  
10 and sizes to display products of different sizes useful for advertising purposes.

[0068] The above description explains rectangular-shaped holographic display device **12**, in accordance with one embodiment of the present invention. **Figs. 15 through 18** show holographic display device **200** having triangular shape/configuration, in accordance with another embodiment of the present invention. Similarly, a person skilled in the art appreciates  
15 that the presently disclosed holographic display device may come in different shapes and sizes. **Fig. 15** shows a perspective view of holographic display device **200**. Holographic display device **200** presents box **202** in a triangular configuration. Box **202** comes in different shapes and sizes. For example, box **02** is big enough e.g., 6 to 7-foot-tall and 3-foot-wide to showcase a full-sized adult. In another example, box **202** comes in a smaller size say 1-2-foot-tall and 1-2  
20 foot-wide to showcase smaller sized products. Box **202** presents bottom frame **204** (similar to bottom frame **22**), top frame **206** (similar to top frame **28**), and side frames **208** (similar to side frames **24;26**). Each of bottom frame **204**, side frames **208** and top frame **206** provides an L-shaped frame made of metal, hard plastic, or any other suitable material. Box **202** presents two side frames **208** at sides and the front presents transparent monitor **214** (similar to transparent  
25 monitor **58**).

[0069] Box **202** encompasses light panels **210** at its sides, top, and rear. Further, box **202** encompasses translucent panel **212** (similar to translucent panel **48**) to diffuse, blend and evenly distribute the high luminosity produced by light panels **210**. In the present embodiment, top frame **206** encompasses camera **216** (similar to first camera **82**) for recording images or video in  
30 its field of view i.e., front of box **202**. Camera **216** mounts through camera mount **218** placed at top of top frame **206**. **Fig. 16** shows the top view of box **202** having camera mount **218**.

Further, side frames **208** encompasses speakers **220** at a suitable height from the ground to enhance the realistic experience of holographic display device **200**.

[0070] Further, box **202** presents fans **222** and vents **224** at side frames **208**. Fans **222** and/or vents **224** blow out hot air generated by light panels **210**. **Fig. 17** shows a rear perspective view of holographic display device **200** having fans **222** and vents **224**. **Fig. 18** shows a side perspective view of holographic display device **200** showing light panels **210**, deck **226** (similar to deck **80**), and power supply mounting plate **228** (similar to power supply mounting plate **81**).

[0071] Holographic display device **200** operates similar to holographic display device **12**.

Holographic display device **200** allows to place it in a corner of a room. In one example, a larger room or building such as a shopping complex houses one or more holographic display devices **12** and/or holographic display device **200**. One or more holographic display devices **12** position at centre of the room and one or more holographic display device **200** position at corners of the room to enhance the visual experience for viewers or audiences.

[0072] Although the above description explains recording images or videos using the image capturing system **18** setups, a person skilled in the art understands that it is possible to capture images or videos using known electronic devices such as a mobile phone or digital camera. Subsequently, the mobile phone transmits the images to the holographic display device **12; 200** to display the hologram-like image on a transparent monitor. Similarly, users capture images using a variety of devices and transmit them to the holographic display device for displaying on the transparent monitor without deviating from the scope of the present invention.

[0073] The embodiments of the present invention described above provide several advantages over the prior art. For example, the present invention presents a hologram-like image effect within a holographic display device when the right content i.e., image is presented on a transparent monitor. The hologram-like image with shadow in its background and reflection at the bottom provides a more realistic and natural-looking content/image. Providing the right amount of light inside the interior allows adjusting depth, dimension, and realistic effect of the hologram-like image displayed on a transparent monitor. Further, the monitor frame allows to push transparent monitor back to control the viewing angle and enhance the three-dimensional (3D) effect of the hologram-like image. In addition, the seamless translucent panel allows the hologram-like image to appear more solid and provides a more realistic hologram illusion.

[0074] While the invention has been described in terms of exemplary embodiments, it is to be understood that the words that have been used are words of description and not of limitation. As is understood by persons of ordinary skill in the art, a variety of modifications can be made without departing from the scope of the invention defined by the following claims, which should  
5 be given their fullest, fair scope.

**WE CLAIM:**

1. A holographic display device for presenting an image having a 3D visual effect, said holographic display device comprising:  
  
a box-like structure;  
  
a plurality of translucent panels comprising a rear translucent panel, a bottom translucent panel, a top translucent panel, and side translucent panels;  
  
wherein said bottom translucent panel is integral and seamless with said rear translucent panel by having a curvature between said bottom translucent panel and said rear translucent panel;  
  
wherein said rear translucent panel and said side panels extend substantially an entire length of said box-like structure;  
  
a plurality of light panels comprising a rear light panel, and side light panels, wherein said plurality of light panels extend substantially the entire length of said box-like structure, wherein said plurality of light panels are positioned between said box-like structure and said plurality of translucent panels; and,  
  
a transparent monitor connecting said box-like structure at its front end, wherein said transparent monitor and said plurality of translucent panels form an interior for said box-like structure,  
  
wherein said transparent monitor receives and displays the image, wherein said plurality of light panels illuminate light and said plurality of translucent panels diffuses, blends and evenly distributes the light in the interior for presenting the image displayed on said transparent monitor as the image having a 3D visual effect; and,  
  
whereby the image displayed on said transparent monitor appears more realistic when said plurality of light panels illuminate said plurality of translucent panels having the curvature between said bottom translucent light panel and said rear translucent panel.
2. The holographic display device of Claim 1, wherein said plurality of translucent panels are made of an acrylic material.
3. The holographic display device of Claim 1, further comprises a monitor frame surrounding said transparent monitor, wherein said monitor frame controls a viewing angle for the image displayed on said transparent monitor.

4. The holographic display device of Claim 3 wherein said monitor frame recesses inwards at of a depth of substantially three inches, thereby controlling the viewing angle for the image displayed on said transparent monitor.
5. The holographic display device of Claim 1, wherein said transparent monitor receives the image from an image source, wherein the image source situates at a location different from said holographic display device.
6. The holographic display device of Claim 1, wherein the image source is an electronic device comprising one of a mobile phone, a digital camera, a laptop, and a desktop.
7. The holographic display device of Claim 1, further comprises speakers connecting said box-like structure, wherein speakers output audio simultaneously with the image displayed on the transparent monitor for presenting an interactive experience.
8. The holographic display device of Claim 6 further comprises a camera connecting said box-like structure, wherein said camera captures a field of view of the holographic display device and allows for transmission to the image source, and wherein capturing the field of view facilitates a real-time interaction between the holographic display device and the image source.
9. The holographic display device of Claim 1, wherein the plurality of light panels comprises at least 11 light-emitting diode (LED) strips.
10. A system for capturing an image of a subject and presenting an image having a 3D visual effect corresponding to the image, the system comprising:
  - an image capturing system, comprising:
    - a sheet;
    - a camera for capturing an image of a subject with the sheet acting as a background for the subject, wherein the image capturing system transmits the image to a holographic display device, and
    - said holographic display device comprising:
      - a box-like structure;
      - a plurality of translucent panels comprising a rear translucent panel, a bottom translucent panel, a top translucent panel, and side translucent panels;

wherein said bottom translucent panel is integral and seamless with said rear translucent panel by having a curvature between said bottom translucent panel and said rear translucent panel, wherein said rear translucent panel and said side translucent panels extend substantially an entire length of said box-like structure;

a plurality of light panels comprising a rear light panel, and side light panels, where said plurality of light panels extend substantially an entire length of said box-like structure, wherein said plurality of light panels are positioned between said box-like structure and said plurality of translucent panels; and,

a transparent monitor connecting said box-like structure at its front end, wherein said transparent monitor and said plurality of translucent panels form an interior for said box-like structure,

wherein said transparent monitor receives and displays the image, wherein said light panels illuminate light and said translucent panel diffuses, blends and evenly

11. A method of presenting an image having a 3D visual effect, said method comprising:

providing a box-like structure;

providing a plurality of translucent panels, said plurality of translucent panels comprises a rear translucent panel, a bottom translucent panel, a top translucent panel, and side translucent panels, wherein said bottom translucent panel is integral and seamless with said rear translucent panel by having a curvature between said bottom translucent panel and said rear translucent panel;

providing a plurality light panels between said box-like structure and said plurality of translucent panels, wherein said plurality of light panels extend entire length of said box-like structure;

providing a transparent monitor connecting said box-like structure;

forming an interior with said transparent monitor and said plurality of translucent panels for said box-like structure;

receiving the image for displaying on said transparent monitor;

illuminating light in the interior using said plurality of light panels;

diffusing, blending and evenly distributing the light in the interior through the plurality of translucent panels; and,

presenting the image displayed on the transparent monitor with well-lit interior.

12. The method of Claim 11 further comprising:

illuminating light onto a subject and forming a shadow of the subject on a sheet;

transmitting the image of the subject, the shadow of the subject on the sheet to the transparent monitor, wherein the shadow of the subject appears to be displayed on the rear translucent panel and bottom translucent panel when the shadow of the subject is actually displayed on transparent monitor, thereby giving an added realistic effect of the image; and,

wherein the image received is pre-recorded or provided in real-time.

1/17

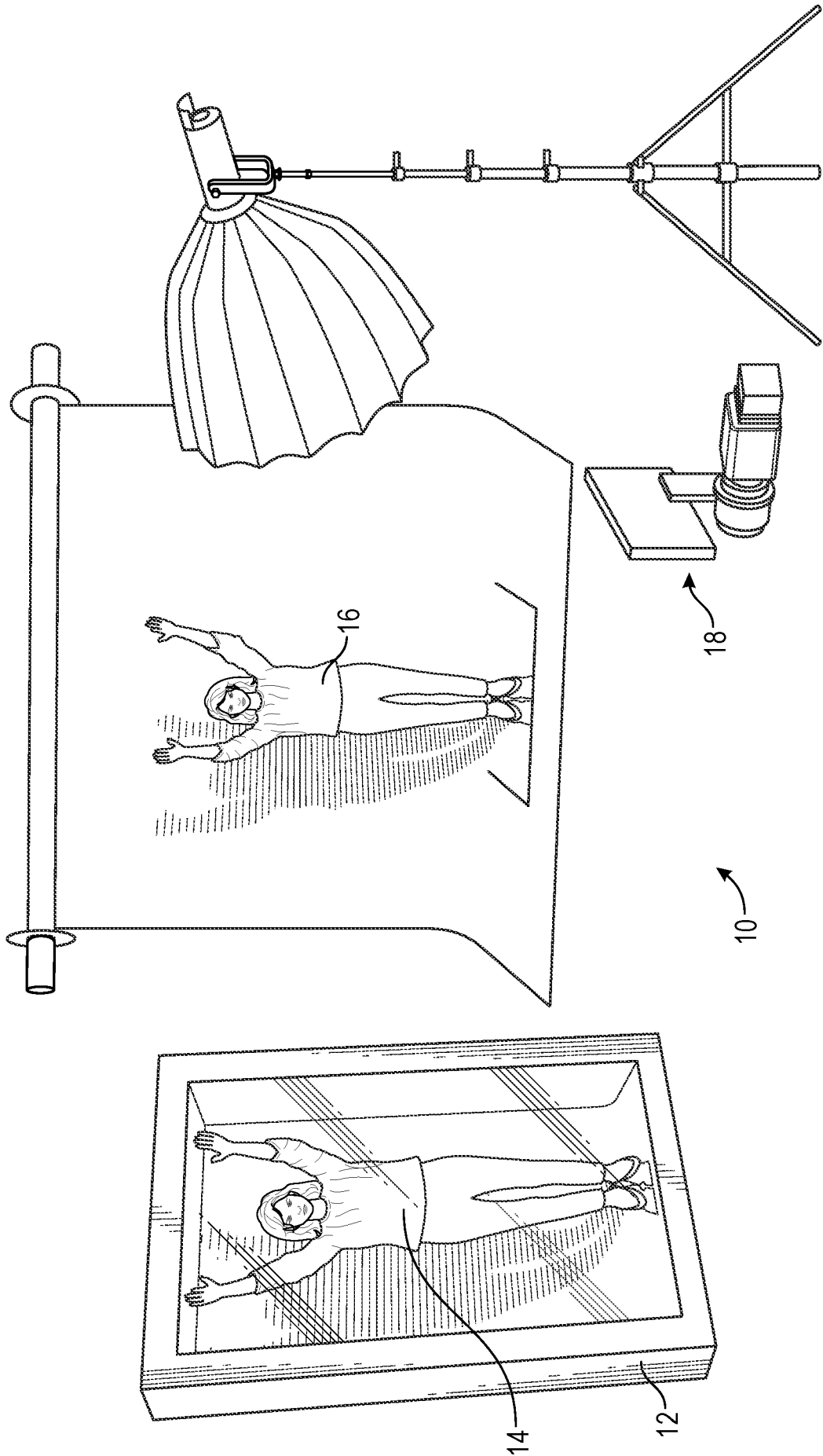

FIG. 1

2/17

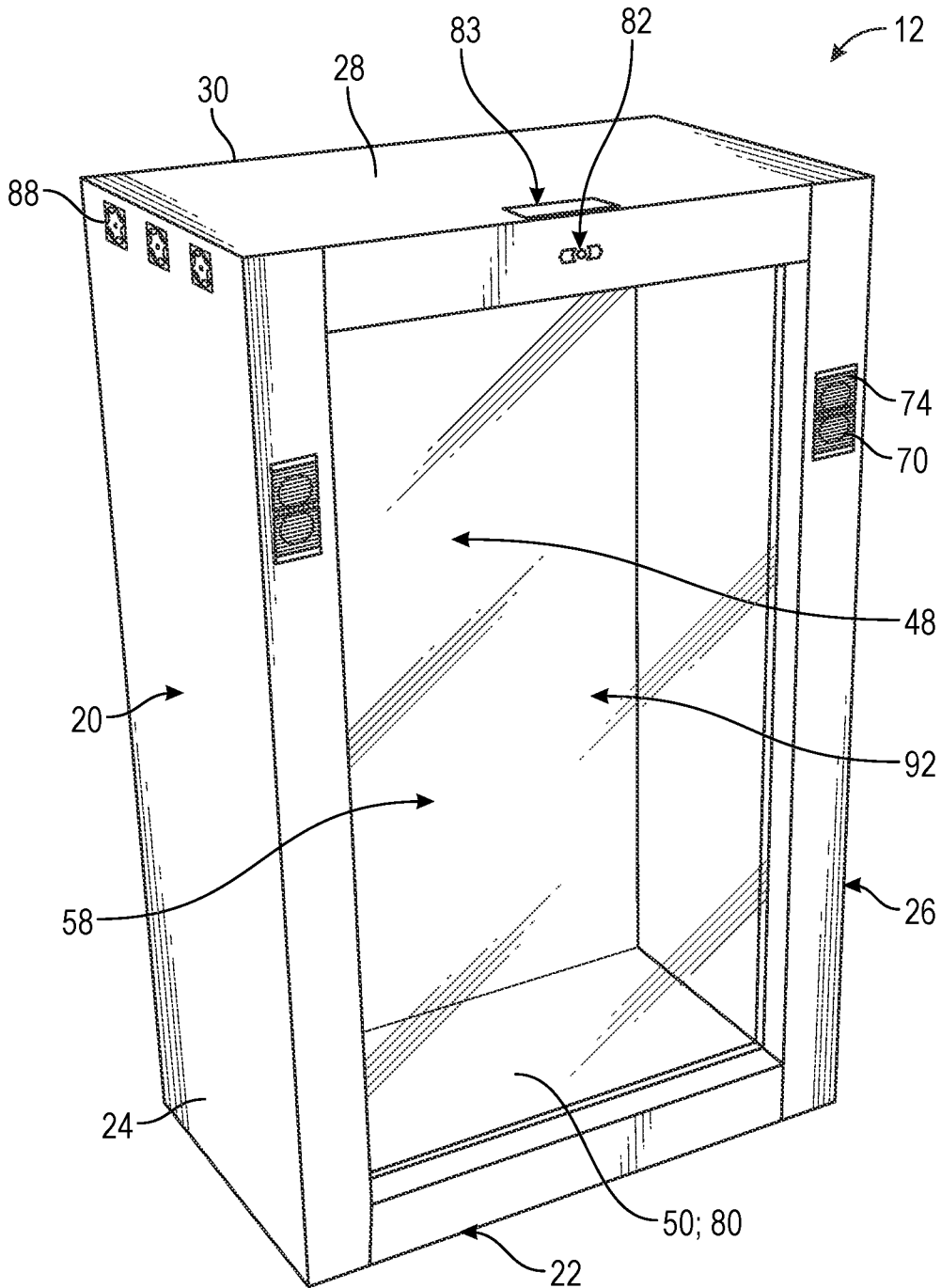

FIG. 2



4/17

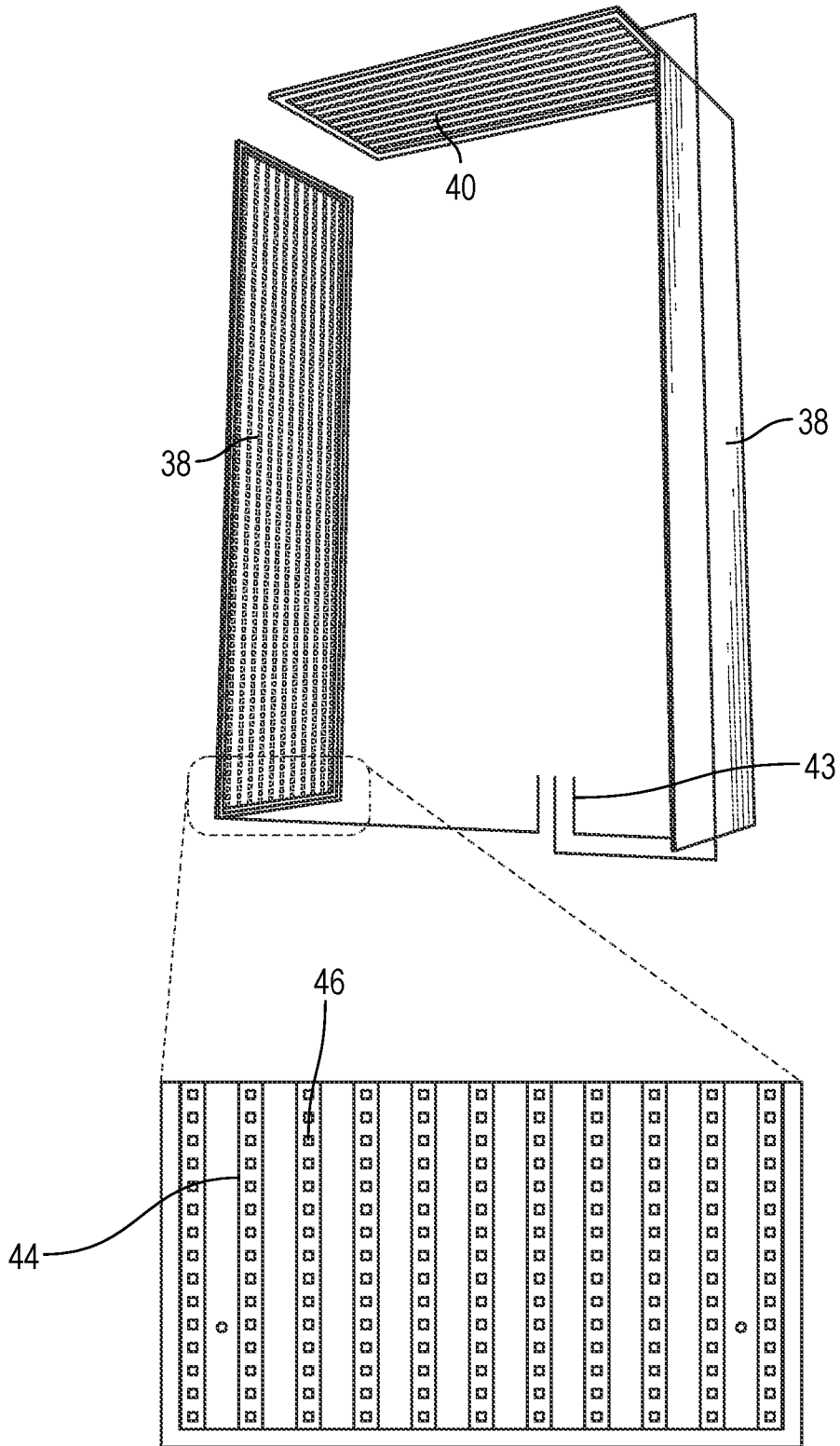

FIG. 4

5/17

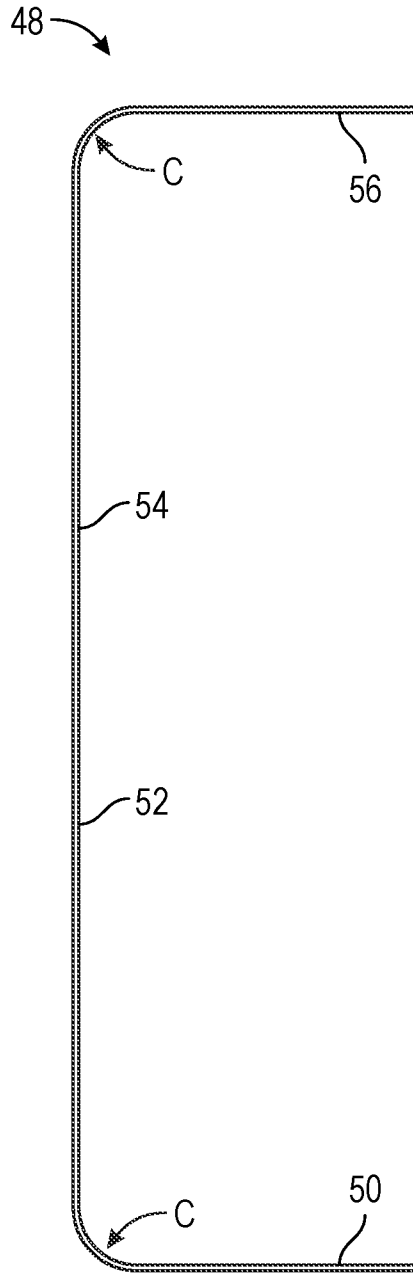

FIG. 5

6/17

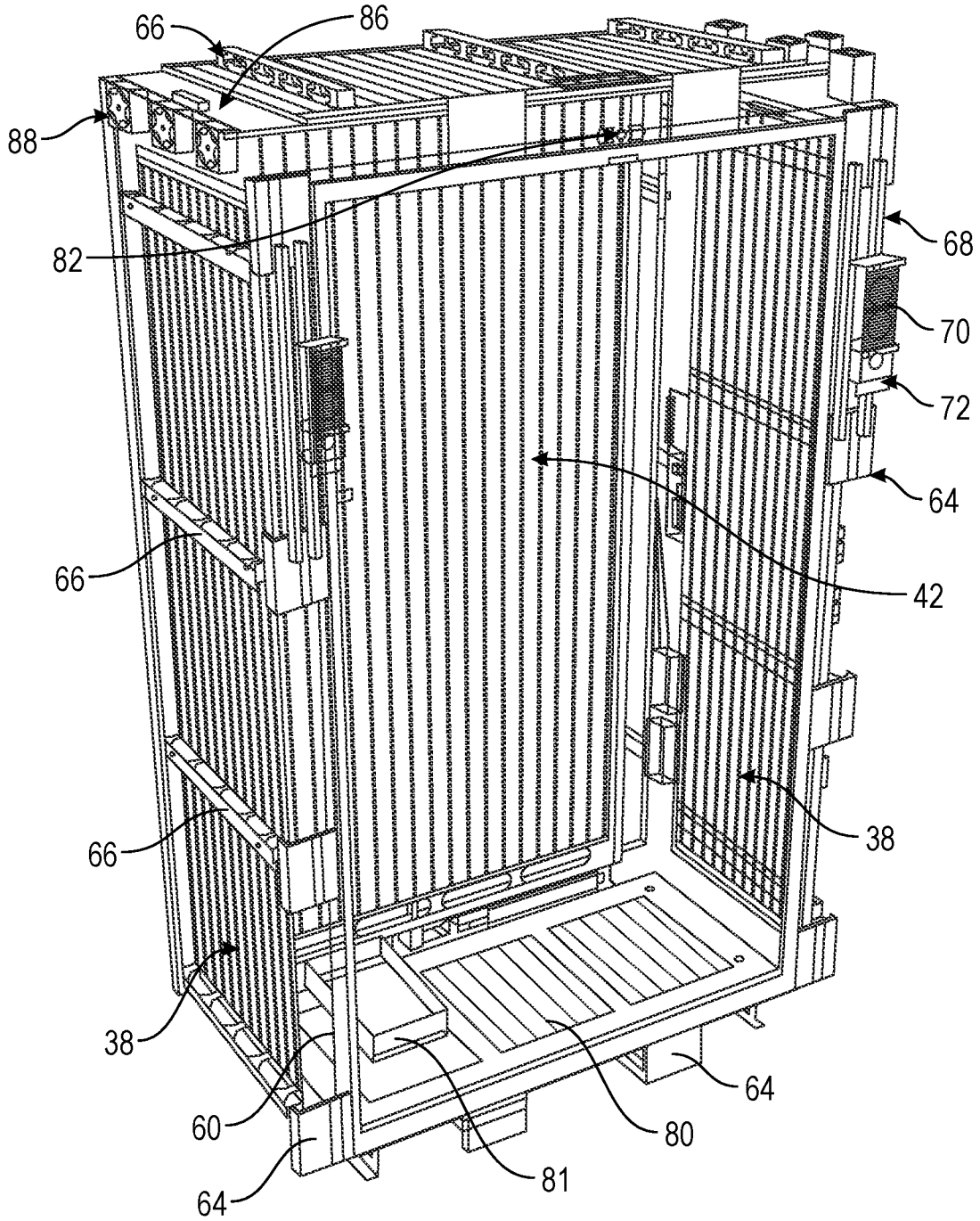

FIG. 6



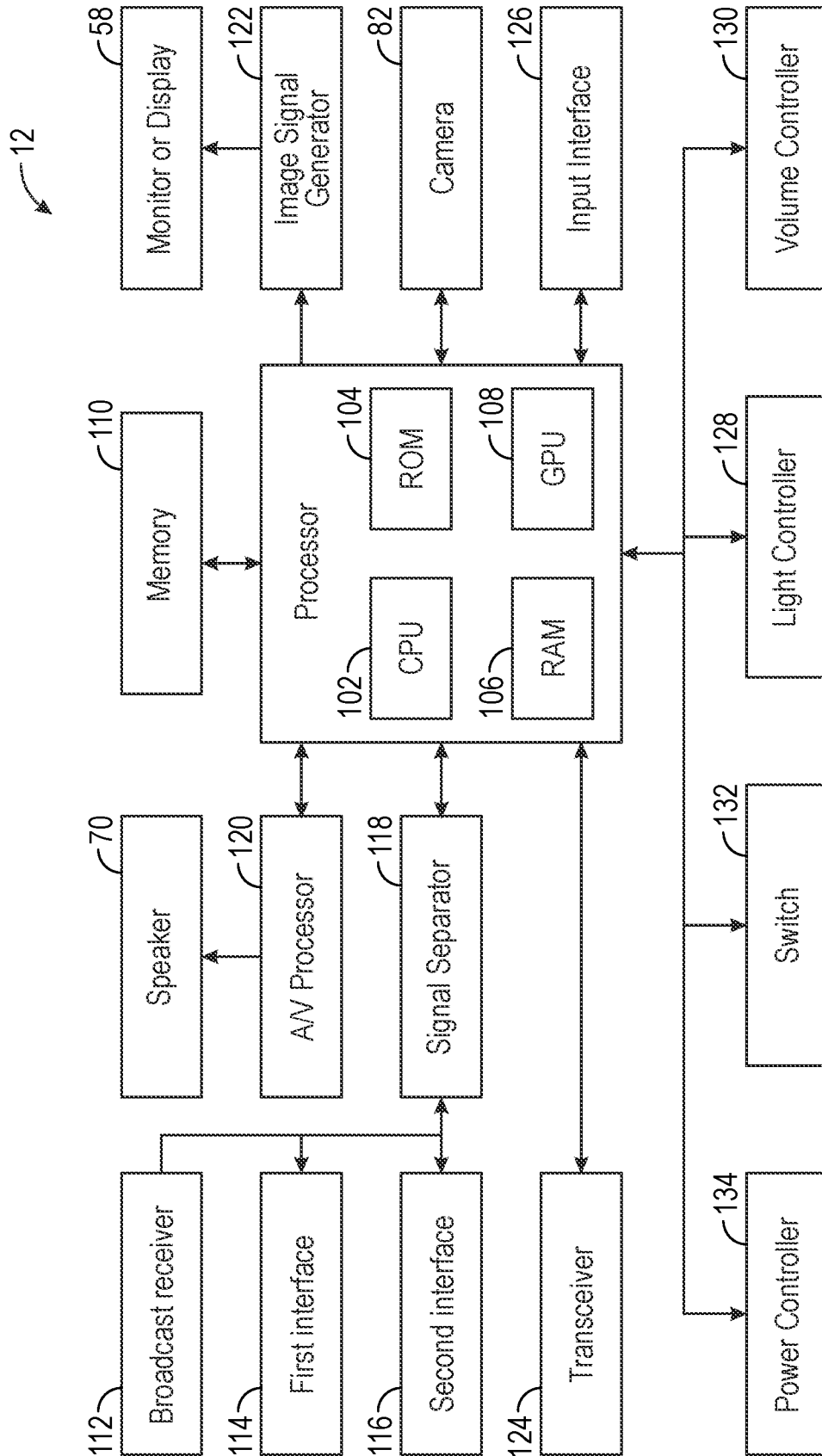

FIG. 8

9/17

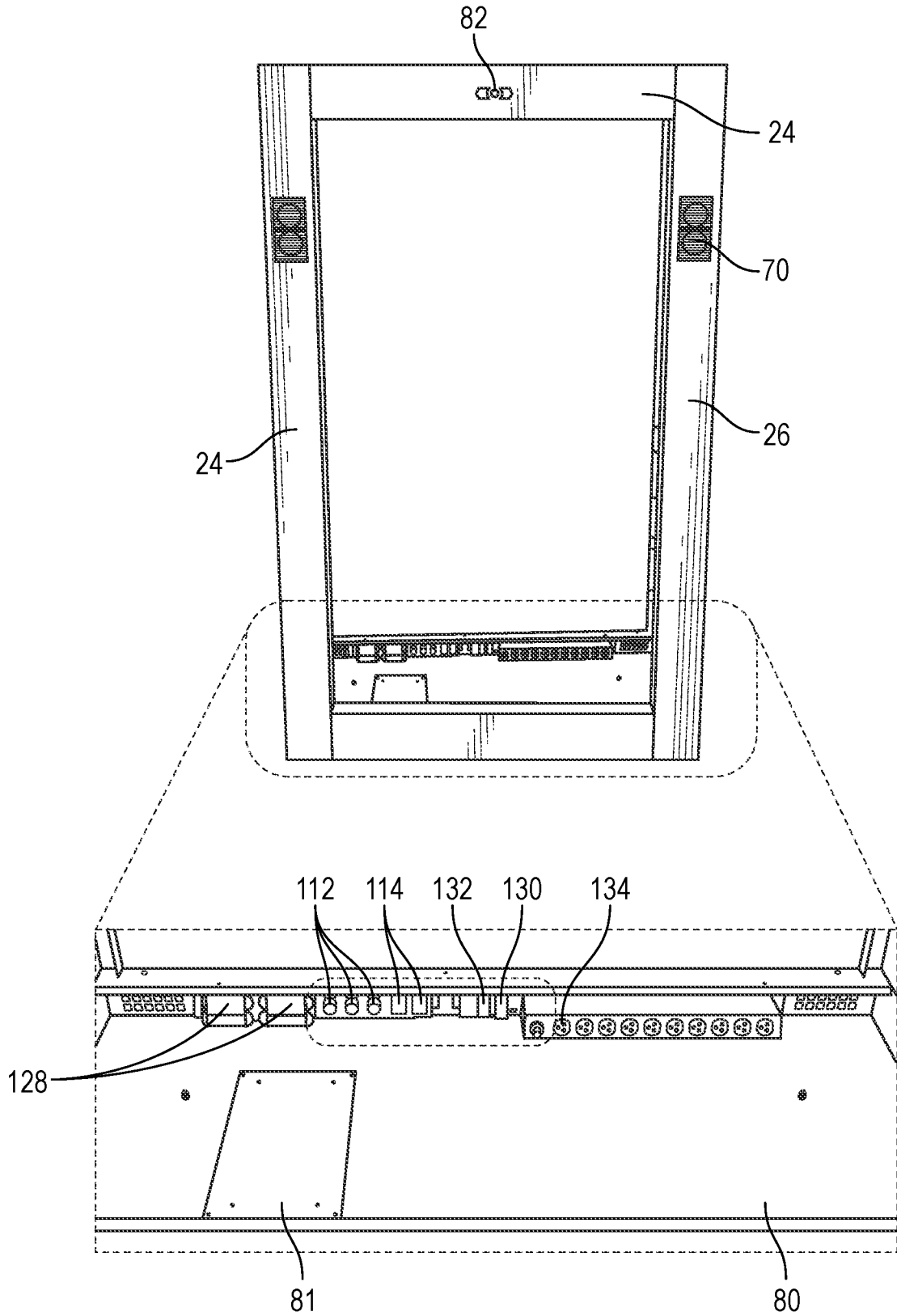

FIG. 9

10/17

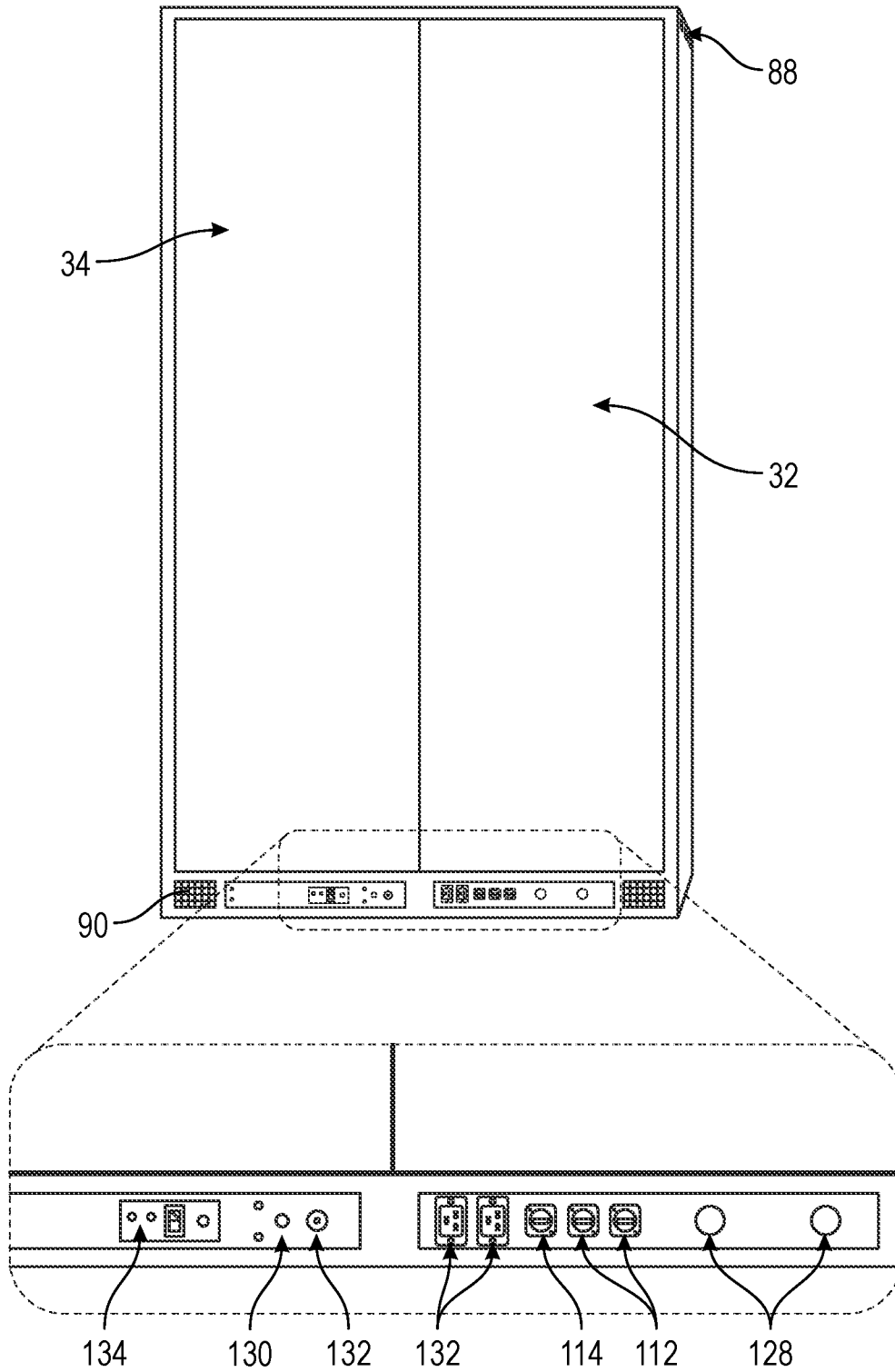

FIG. 10



12/17

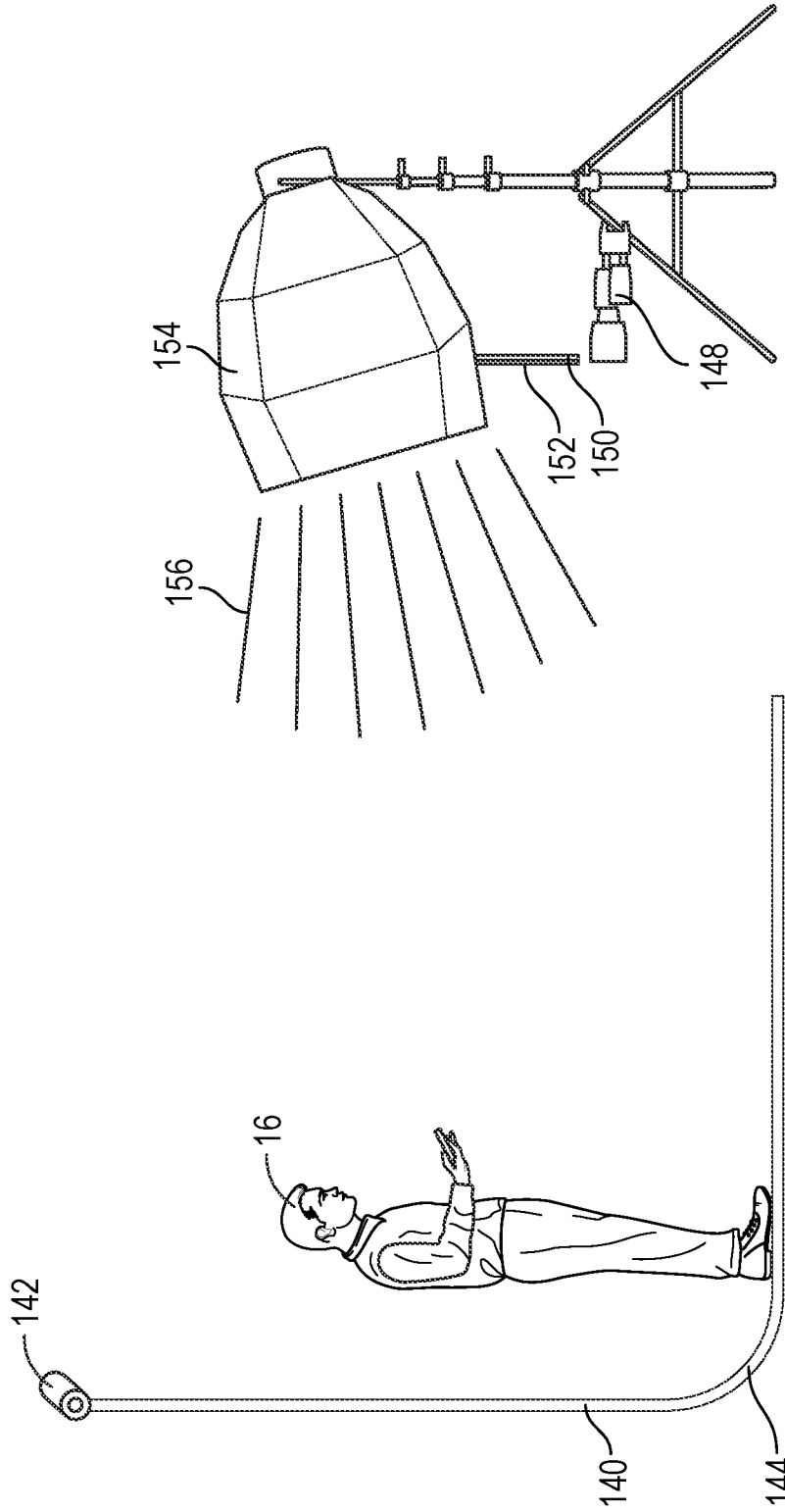

FIG. 12

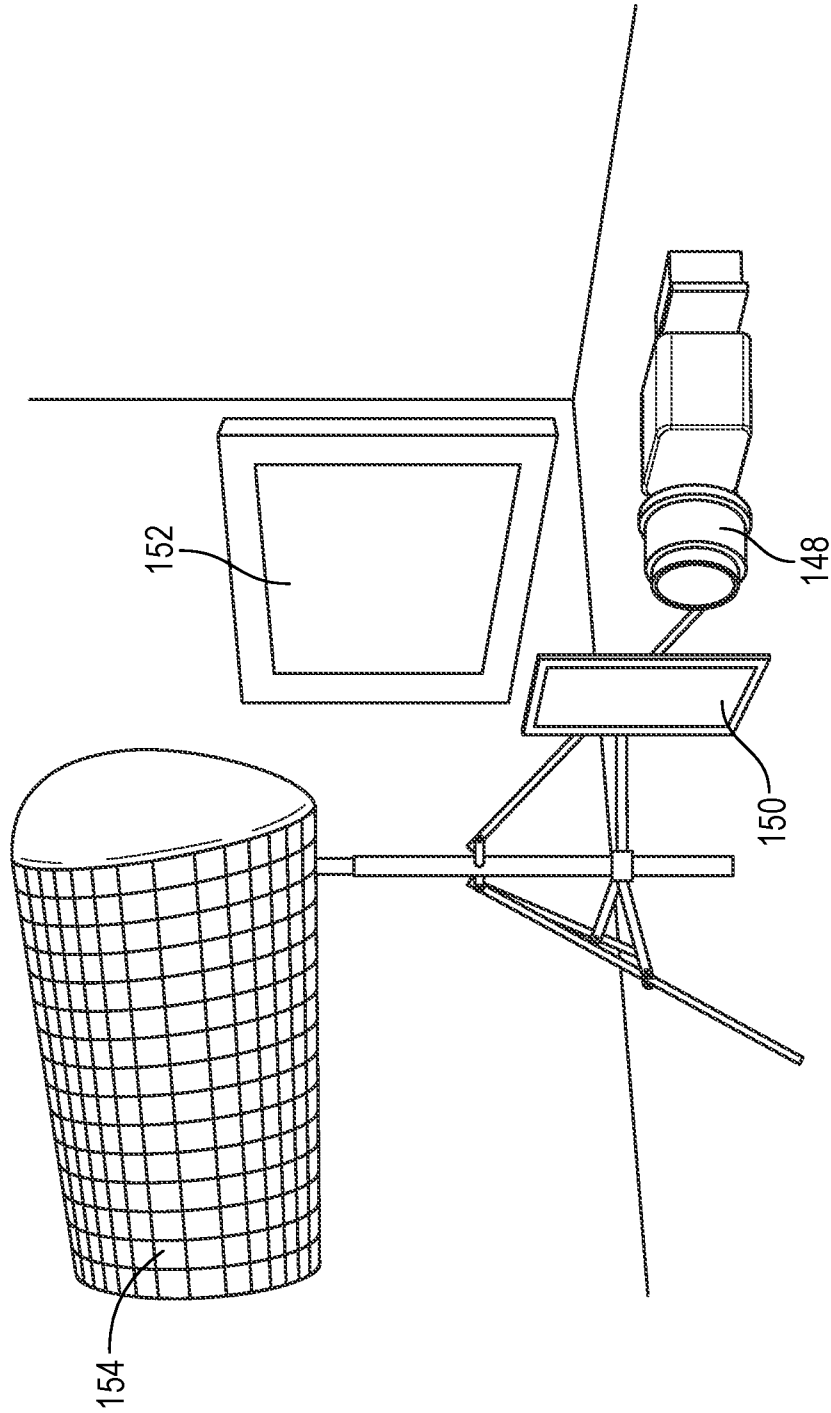

FIG. 13

14/17

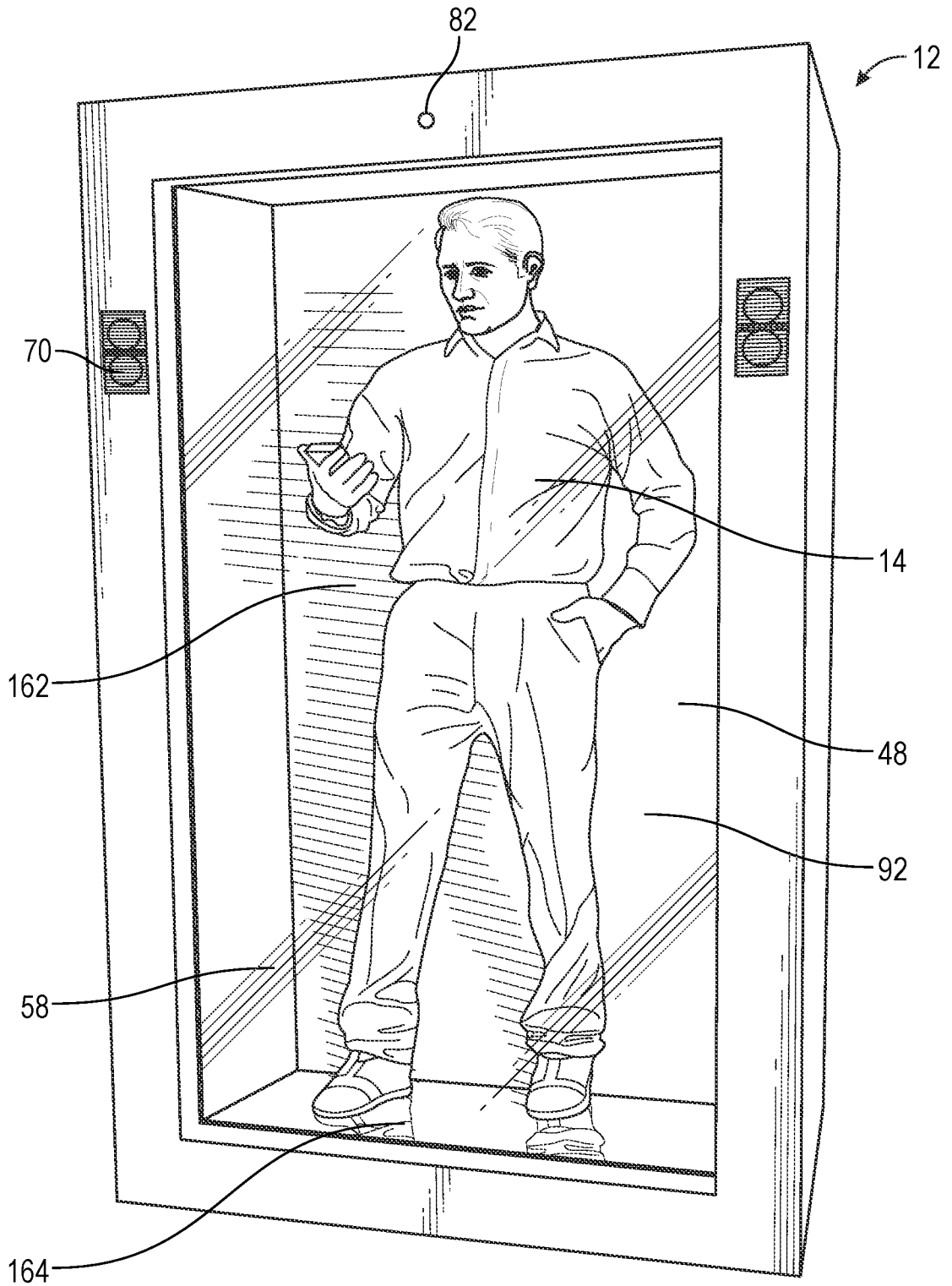

FIG. 14

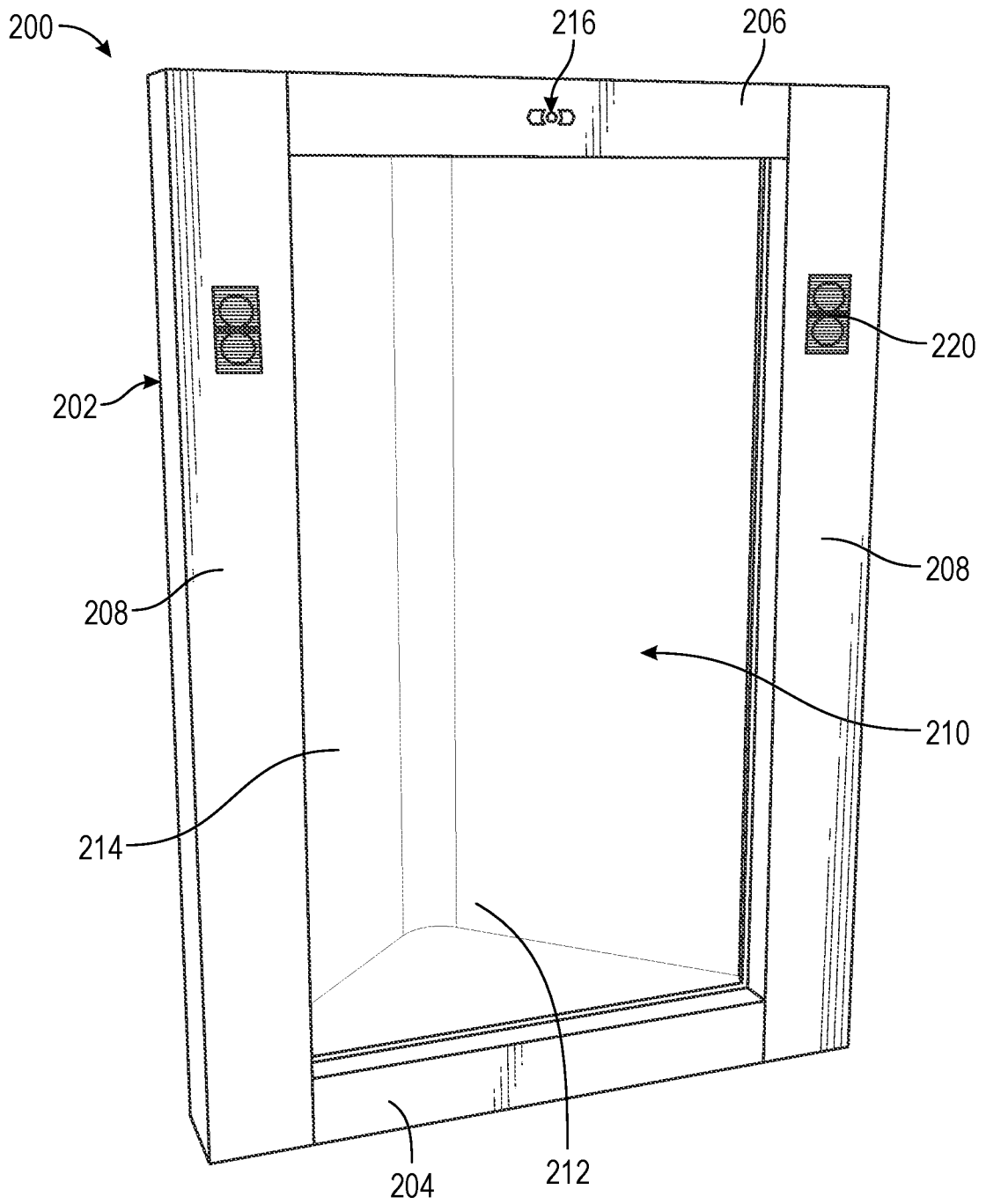

FIG. 15

16/17

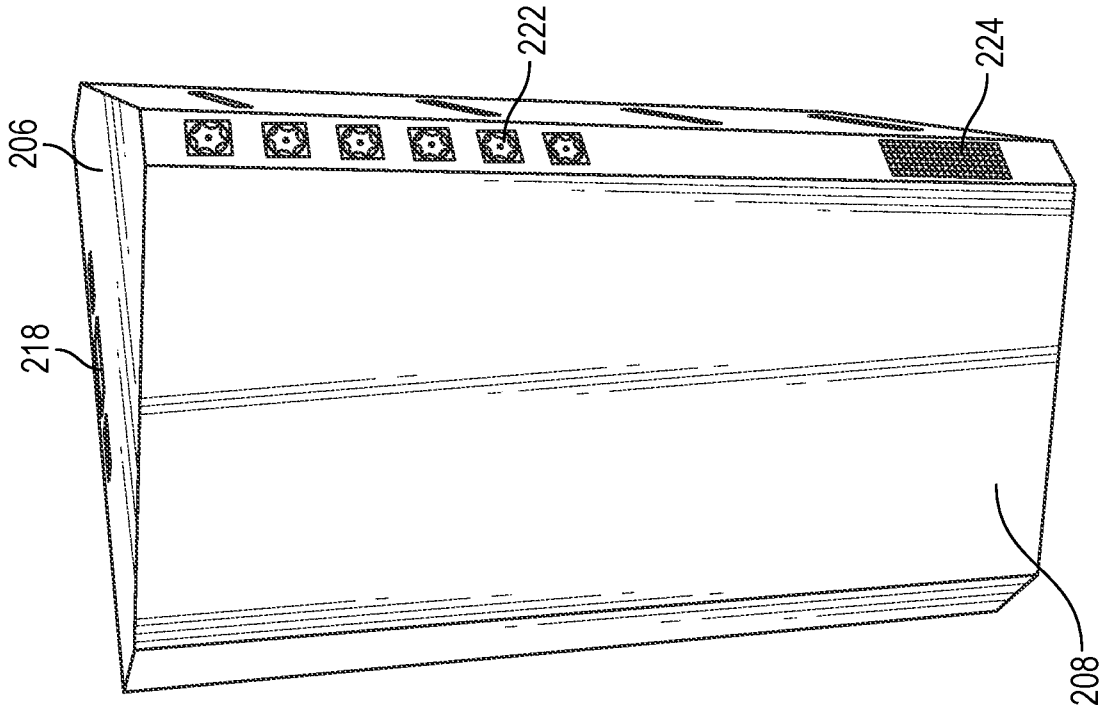

FIG. 17

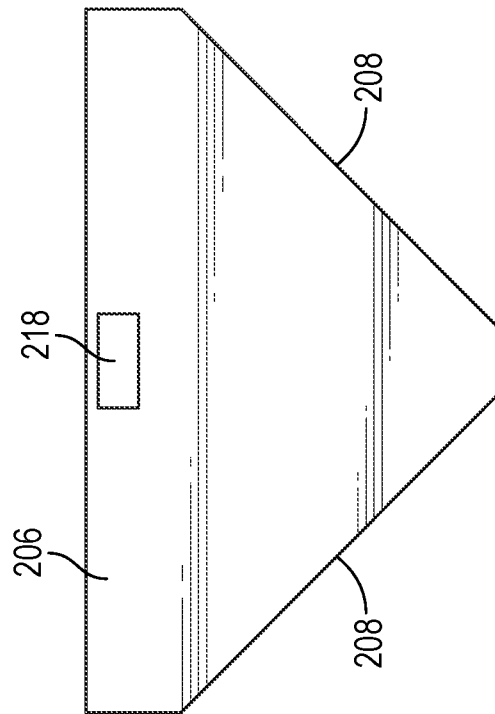

FIG. 16

17/17

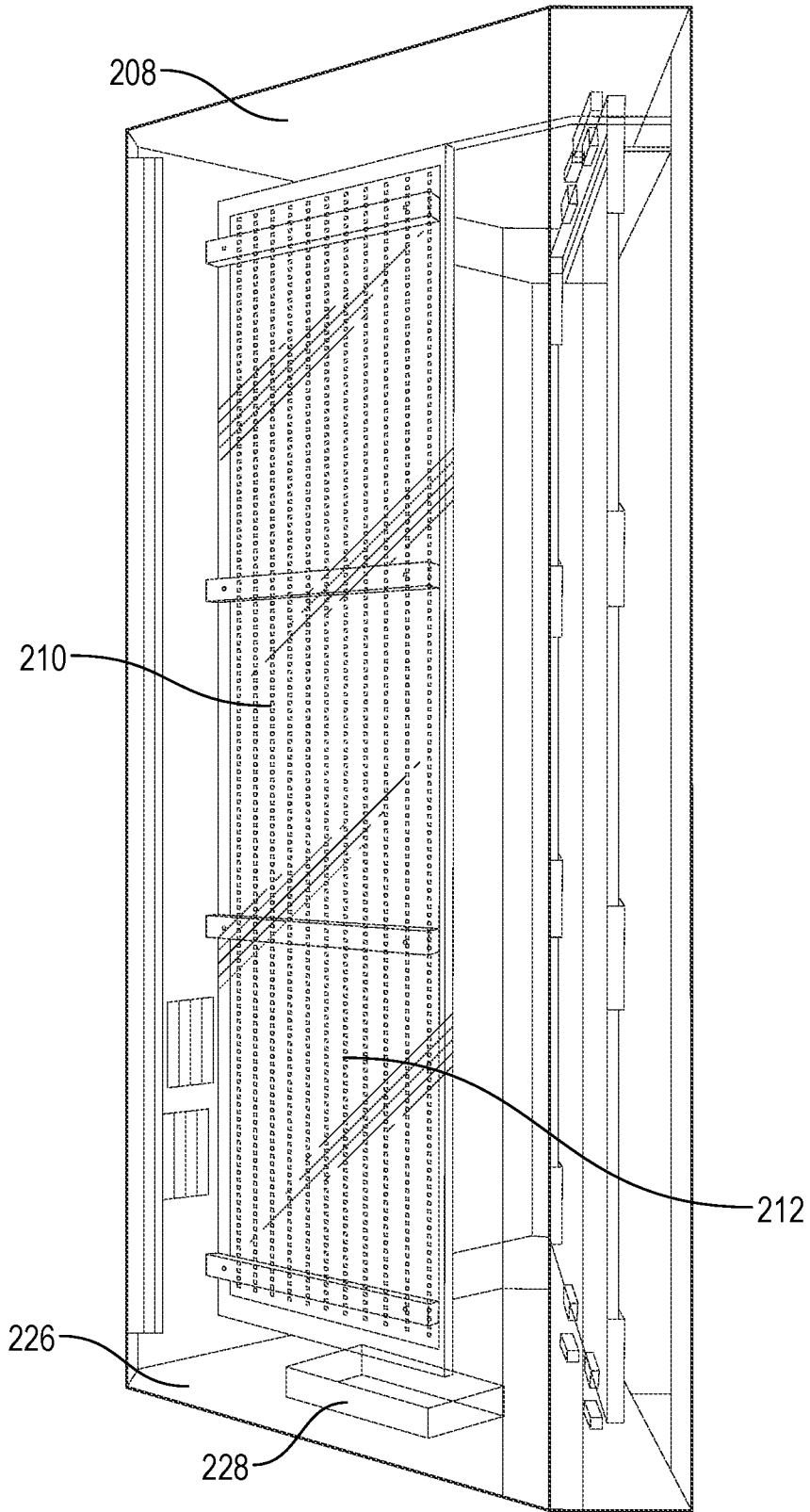

FIG. 18

