

(19) World Intellectual Property Organization
International Bureau



(43) International Publication Date
12 May 2011 (12.05.2011)

PCT

(10) International Publication Number
WO 2011/056708 A1

(51) International Patent Classification:
B65D 1/02 (2006.01) *B65D 79/00* (2006.01)

thony, J. [US/US]; 184 Camelot Arms, York, PA 17406 (US).

(21) International Application Number:
PCT/US2010/054460

(74) Agent: **KNOBLE, John, L.**; Knoble Yoshida & Dunleavy, LLC, 1628 John F. Kennedy Boulevard, Eight Penn Center, Suite 1350, Philadelphia, PA 19103 (US).

(22) International Filing Date:
28 October 2010 (28.10.2010)

(81) Designated States (unless otherwise indicated, for every kind of national protection available): AE, AG, AL, AM, AO, AT, AU, AZ, BA, BB, BG, BH, BR, BW, BY, BZ, CA, CH, CL, CN, CO, CR, CU, CZ, DE, DK, DM, DO, DZ, EC, EE, EG, ES, FI, GB, GD, GE, GH, GM, GT, HN, HR, HU, ID, IL, IN, IS, JP, KE, KG, KM, KN, KP, KR, KZ, LA, LC, LK, LR, LS, LT, LU, LY, MA, MD, ME, MG, MK, MN, MW, MX, MY, MZ, NA, NG, NI, NO, NZ, OM, PE, PG, PH, PL, PT, RO, RS, RU, SC, SD, SE, SG, SK, SL, SM, ST, SV, SY, TH, TJ, TM, TN, TR, TT, TZ, UA, UG, US, UZ, VC, VN, ZA, ZM, ZW.

(25) Filing Language: English

(26) Publication Language: English

(30) Priority Data:
12/614,831 9 November 2009 (09.11.2009) US

(71) Applicant (for all designated States except US): **GRAHAM PACKAGING COMPANY, L.P.** [US/US]; 2401 Pleasant Valley Road, York, PA 17402 (US).

(72) Inventors; and
(75) Inventors/Applicants (for US only): **GILL, Matthew, T.** [US/US]; 342b Friendship Avenue, Hellam, PA 17406 (US). **HOWELL, Justin, A.** [US/US]; 1530 Brandt Avenue, New Cumberland, PA 17070 (US). **SCHLIES, An-**

(84) Designated States (unless otherwise indicated, for every kind of regional protection available): ARIPO (BW, GH, GM, KE, LR, LS, MW, MZ, NA, SD, SL, SZ, TZ, UG, ZM, ZW), Eurasian (AM, AZ, BY, KG, KZ, MD, RU, TJ, TM), European (AL, AT, BE, BG, CH, CY, CZ, DE, DK,

[Continued on next page]

(54) Title: PLASTIC CONTAINER WITH IMPROVED SIDEWALL CONFIGURATION

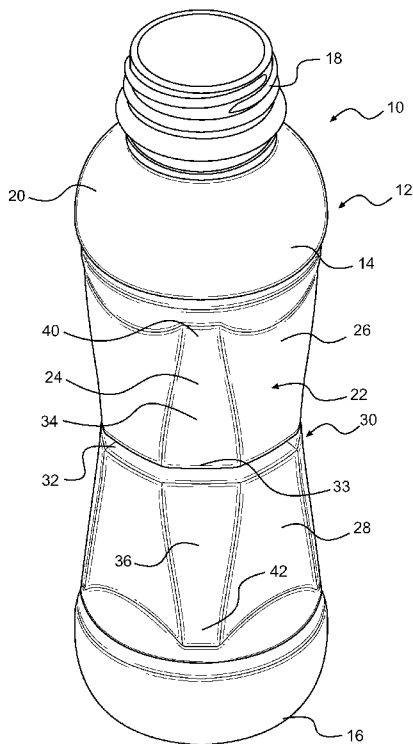

FIG. 1

(57) Abstract: A plastic container (10) that is adapted for adjustment to internal volumetric changes such as those that occur during the hot-fill process includes a container body (12) defining an internal space and having a sidewall (14). The container body has a maximum lateral dimension and a plurality of flexible panels and posts (24) defined in the sidewall. The posts (24) are respectively interposed between the flexible panels (22) around the outer circumference of the sidewall. Each of the plurality of posts (24) has a minimum width and a maximum width, and a ratio of the minimum width to maximum width is preferably within a range of about 0.3 to about 0.7. A ratio of the minimum width to the maximum lateral dimension is preferably within a range of about 0.05 to about 0.30. In addition, a ratio of the maximum width to the maximum lateral dimension is preferably within a range of about 0.15 to about 0.45.

WO 2011/056708 A1

EE, ES, FI, FR, GB, GR, HR, HU, IE, IS, IT, LT, LU,
LV, MC, MK, MT, NL, NO, PL, PT, RO, RS, SE, SI, SK,
SM, TR), OAPI (BF, BJ, CF, CG, CI, CM, GA, GN, GQ,
GW, ML, MR, NE, SN, TD, TG).

— *as to the applicant's entitlement to claim the priority of
the earlier application (Rule 4.17(iii))*

Published:

— *with international search report (Art. 21(3))*

Declarations under Rule 4.17:

— *as to applicant's entitlement to apply for and be granted
a patent (Rule 4.17(ii))*

PLASTIC CONTAINER WITH IMPROVED SIDEWALL CONFIGURATION

BACKGROUND OF THE INVENTION

1. Field of the Invention

[0001] This invention relates generally to the field of plastic containers, and more particularly to plastic containers that are designed to accommodate volumetric expansion and contraction such as that inherent to the hot-fill packaging process or to packaging applications where internal pressurization is anticipated.

2. Description of the Related Technology

[0002] Many products that were previously packaged using glass containers are now being supplied in plastic containers, such as containers that are fabricated from polyesters such as polyethylene terephthalate (PET).

[0003] PET containers are typically manufactured using the stretch blow molding process. This involves the use of a preform that is injection molded into a shape that facilitates distribution of the plastic material within the preform into the desired final shape of the container. The preform is first heated and then is longitudinally stretched and subsequently inflated within a mold cavity so that it assumes the desired final shape of the container. As the preform is inflated, it takes on the shape of the mold cavity. The polymer solidifies upon contacting the cooler surface of the mold, and the finished hollow container is subsequently ejected from the mold.

[0004] Hot fill containers are designed to be used with the conventional hot fill process in which a liquid or semi-solid product such as fruit juice, sauce, salsa, jelly or fruit salad is introduced into the container while warm or hot, as appropriate, for sanitary packaging of the product. After filling, such containers undergo significant volumetric shrinkage as a result of the cooling of the product within the sealed container. Hot fill type containers accordingly must be designed to have the capability of accommodating such shrinkage. Typically this has been done by incorporating one or more vacuum panels into the side wall of the container that

are designed to flex inwardly as the volume of the product within the container decreases as a result of cooling.

[0005] Typically, the vacuum panel regions of conventional hot fill containers are characterized by having surfaces that are designed to deflect inwardly when the product within the sealed container undergoes shrinkage. The amount of volumetric contraction, also referred to as vacuum uptake, that can be provided by a conventional vacuum panel is limited by the size of the panel. The design of such containers is often influenced by the aesthetic preferences of manufacturers, which in some instances can limit the size of the vacuum panels to the extent that makes it difficult or impossible to achieve the necessary vacuum uptake capacity.

[0006] In certain types of hot-fill containers, the flexible vacuum panels are disposed about the entire circumference of the container sidewall, separated from each other by a corresponding number of posts that are interposed between the vacuum panels. One problem that has afflicted many conventional hot-fill container designs of this type is uneven or asymmetric deflection of the different vacuum panels under vacuum uptake conditions. The possibility of such inconsistent deformation makes it difficult to reliably design a container having the desired amount of vacuum uptake capability, and it is also unsightly.

[0007] A need therefore exists for an improved vacuum panel configuration that achieves a maximal amount of reliability in terms of vacuum panel deflection under vacuum uptake conditions.

SUMMARY OF THE INVENTION

[0008] Accordingly, it is an object of the invention to provide an improved vacuum panel configuration that achieves a maximal amount of reliability in terms of vacuum panel deflection under vacuum uptake conditions.

[0009] In order to achieve the above and other objects of the invention, a plastic container that is adapted for adjustment to internal volumetric changes according to a first aspect of the invention includes a container body defining an internal space. The container body has a maximum lateral dimension and a sidewall comprising a plurality of flexible panels and a

corresponding plurality of posts. The posts are respectively interposed between the flexible panels. Each of the plurality of posts has a minimum width and a maximum width, and a ratio of the minimum width to the maximum width is within a range of about 0.30 to about 0.70.

[00010] A plastic container according to a second aspect of the invention is adapted for adjustment to internal volumetric changes and includes a container body defining an internal space. The container body has a maximum lateral dimension and a sidewall comprising a plurality of flexible panels and a corresponding plurality of posts. The posts are respectively interposed between the flexible panels. Each of the plurality of posts has a minimum width, and a ratio of the minimum width to the maximum lateral dimension is within a range of about 0.05 to about 0.30.

[00011] A plastic container according to a third aspect of the invention is adapted for adjustment to internal volumetric changes and includes a container body defining an internal space. The container body has a maximum lateral dimension and a sidewall comprising a plurality of flexible panels and a corresponding plurality of posts. The posts are respectively interposed between the flexible panels. Each of the plurality of posts has a maximum width, and a ratio of the maximum width to the maximum lateral dimension is within a range of about 0.15 to about 0.45.

[00012] These and various other advantages and features of novelty that characterize the invention are pointed out with particularity in the claims annexed hereto and forming a part hereof. However, for a better understanding of the invention, its advantages, and the objects obtained by its use, reference should be made to the drawings which form a further part hereof, and to the accompanying descriptive matter, in which there is illustrated and described a preferred embodiment of the invention.

BRIEF DESCRIPTION OF THE DRAWINGS

[00013] FIGURE 1 is a perspective view of a container that is constructed according to a preferred embodiment of the invention;

[00014] FIGURE 2 is a side elevational view of the container shown in FIGURE 1;

[00015] FIGURE 3 is a cross-sectional view taken along lines 3-3 in FIGURE 2;

[00016] FIGURE 4 is a cross-sectional view taken along lines 4-4 in FIGURE 2;

[00017] FIGURE 5 is a cross-sectional view taken along lines 5-5 in FIGURE 2; and

[00018] FIGURE 6 is a cross-sectional view taken along lines 6-6 in FIGURE 2.

DETAILED DESCRIPTION OF THE PREFERRED EMBODIMENT(S)

[00019] Referring now to the drawings, wherein like reference numerals designate corresponding structure throughout the views, and referring in particular to FIGURE 1, a plastic container 10 that is constructed according to a preferred embodiment of the invention includes a container body 12 having a sidewall 14, a bottom portion 16 and a threaded finish portion 18.

[00020] Plastic container 10 is preferably of unitary construction and is preferably fabricated from a plastic material such as polyethylene terephthalate (PET) using a conventional molding process such as the reheat stretch blow molding process.

[00021] Plastic container 10 is adapted for adjustment to internal volumetric changes, such as those that occur during the well-known hot-fill process.

[00022] In the preferred embodiment, container body 12 includes a rounded upper dome portion 20 having an outer surface that is substantially circular as viewed in transverse cross-section and that defines at a lower portion thereof a maximum lateral dimension or diameter D_{MAX} of the container 10. Alternatively, the container could be structured so that the maximum lateral dimension is at a different location.

[00023] The sidewall 14 of the container body 12 preferably includes a plurality of flexible vacuum panels 22 and a corresponding plurality of posts 24. In the preferred embodiment, the posts 24 are respectively interposed between the flexible panels 22 about the entire circumference of the container body 12. Preferably, each of the vacuum panels 22 includes an upper panel portion 26 and a lower panel portion 28. The upper and lower panel portions 26, 28 are separated by a discontinuity 30 in the sidewall 14 that in the preferred embodiment

is a circumferential groove 32 that is oriented so as to reside within a plane that is transverse to a longitudinal axis of the container 10.

[00024] The posts 24 are also divided in the preferred embodiment into upper post portions 34 and lower posts portions 36 by the discontinuity 30. In this embodiment, the discontinuity 30 is constructed as a concave, inwardly extending groove 32 that is defined in the sidewall 14. As shown in FIGURE 6, the groove 32 as viewed in transverse cross-section has a inwardmost surface that is generally octagonal in shape, with each of the sides preferably having substantially the same length.

[00025] The groove 32 in the preferred embodiment has four sides that are aligned with the flexible vacuum panels 22 and that have a length A_C , and four sides that are aligned with the posts 24 and that have a length O_C that is preferably substantially the same as length A_C . In the preferred embodiment, lengths O_C and A_C are preferably within a range of about 0.25 to about 0.30 as a ratio with respect to the maximum lateral dimension D_{MAX} of the container 10.

[00026] Each of the sides is preferably slightly convex, having a radius of curvature R_2 that is preferably within a range of 0.1 to about 1.0.

[00027] Each of the posts 24 in the preferred embodiment has a minimum width O_{MIN} as viewed in side elevation and a maximum width O_{MAX} , also as viewed in side elevation. A ratio of the minimum width O_{MIN} to the maximum width O_{MAX} is preferably within a range of about 0.3 to about 0.7, more preferably within a range of about 0.4 to about 0.6, and most preferably within a range of about 0.5 to about 0.55.

[00028] As is best shown in FIGURES 1 and 2, each of the plurality of posts 24 in the preferred embodiment is tapered as viewed in side elevation. Each of a plurality of posts 24 has a mid portion 38, an upper distal portion 40 and a lower distal portion 42, and is shaped so as to be wider when viewed in side elevation as shown in FIGURE 2 at the mid portion 38 than at at least one of the upper and lower distal portions 40, 42. In the preferred embodiment, all of the posts 24 have substantially the same shape and dimensions, and are shaped so as to be wider at their mid portions 38 than at both of their respective upper and lower distal portions 40, 42.

[00029] The minimum width O_{MIN} of each of the posts 24, shown in cross-section in FIGURE 3, is preferably located substantially at the upper distal portion 40, with a corresponding minimum width being located substantially at the lower distal portion 42. A maximum width O_{MAX} of each of the posts 24, shown in cross-section in FIGURE 5, is preferably located near the mid portion 38, immediately adjacent to the groove 32. FIGURE 4 is a transverse cross-sectional view taken at an intermediate location between the mid portion 38 and the upper distal portion 40. It shows an intermediate width O_1 that is preferably greater than the minimum width O_{MIN} and less than the maximum width O_{MAX} .

[00030] A ratio of the minimum post width O_{MIN} to the maximum lateral dimension D_{MAX} of the container 10 is preferably within a range of about 0.05 to about 0.30, more preferably within a range of about 0.075 to about 0.25, and most preferably within a range of about 0.1 to about 0.2.

[00031] A ratio of the maximum post width O_{MAX} to the maximum lateral dimension D_{MAX} is preferably within a range of about 0.15 to about 0.45, more preferably within a range of about 0.175 to about 0.4, and most preferably within a range of about 0.2 to about 0.35.

[00032] The flexible panels 22 are generally complementary in shape to the posts 24, and in the preferred embodiment are generally hourglass-shaped. As shown in FIGURE 3, a maximum panel width A_{MAX} is located near the top of the upper panel portion 26, within a common transverse plane as the minimum post width O_{MIN} . Within this transverse plane, the vacuum panel 22 preferably is slightly convex and has a radius of curvature R_1 .

[00033] A minimum panel width A_{MIN} , shown in FIGURE 5, is preferably located near the bottom of the upper panel portion 26, within a common transverse plane as the maximum post width O_{MAX} . Within this transverse plane, the vacuum panel 22 preferably is slightly convex and has a radius of curvature R_3 .

[00034] FIGURE 4 is a transverse cross-sectional view taken at an intermediate location within the upper panel portion 26. It shows an intermediate panel width A_1 that is preferably greater than the minimum panel width A_{MIN} and less than the maximum panel width A_{MAX} . Within this transverse plane, the vacuum panel 22 preferably is slightly convex and has a radius of curvature R_2 . Radii R_1 , R_2 and R_3 are preferably substantially equal.

[00035] It is to be understood, however, that even though numerous characteristics and advantages of the present invention have been set forth in the foregoing description, together with details of the structure and function of the invention, the disclosure is illustrative only, and changes may be made in detail, especially in matters of shape, size and arrangement of parts within the principles of the invention to the full extent indicated by the broad general meaning of the terms in which the appended claims are expressed.

WHAT IS CLAIMED IS:

1. A plastic container that is adapted for adjustment to internal volumetric changes, comprising:

a container body defining an internal space, said container body having a maximum lateral dimension and a sidewall comprising a plurality of flexible panels and a corresponding plurality of posts, said posts being respectively interposed between said flexible panels;

wherein each of said plurality of posts has a minimum width and a maximum width, and wherein a ratio of said minimum width to said maximum width is within a range of about 0.3 to about 0.7.

2. A plastic container according to claim 1, wherein said ratio of said minimum width to said maximum width is within a range of about 0.4 to about 0.6.

3. A plastic container according to claim 2, wherein said ratio of said minimum width to said maximum width is within a range of about 0.5 to about 0.55.

4. A plastic container according to claim 1, wherein each of said plurality of posts is tapered as viewed in side elevation.

5. A plastic container according to claim 4, wherein each of said plurality of posts has a mid portion, an upper distal portion and a lower distal portion, and is shaped so as to be wider when viewed in side elevation at said mid portion than at at least one of said upper and lower distal portions.

6. A plastic container according to claim 5, wherein each of said plurality of posts is shaped so as to be wider when viewed in side elevation at said mid portion than at both of said upper and lower distal portions.

7. A plastic container according to claim 1, wherein said sidewall further comprises a discontinuity extending circumferentially about a longitudinal mid portion of said container body.

8. A plastic container according to claim 7, wherein said discontinuity comprises a groove defined in said sidewall.
9. A plastic container according to claim 8, wherein said groove is substantially octagonal as viewed in transverse cross section.
10. A plastic container according to claim 1, wherein each of said plurality of flexible panels is generally hourglass-shaped.
11. A plastic container according to claim 1, wherein a ratio of said minimum width to said maximum lateral dimension is within a range of about 0.05 to about 0.30.
12. A plastic container according to claim 1, wherein a ratio of said maximum width to said maximum lateral dimension is within a range of about 0.15 to about 0.45.
13. A plastic container that is adapted for adjustment to internal volumetric changes, comprising:
 - a container body defining an internal space, said container body having a maximum lateral dimension and a sidewall comprising a plurality of flexible panels and a corresponding plurality of posts, said posts being respectively interposed between said flexible panels;
 - wherein each of said plurality of posts has a minimum width, and wherein a ratio of said minimum width to said maximum lateral dimension is within a range of about 0.05 to about 0.30.
14. A plastic container according to claim 13, wherein said ratio of said minimum width to said maximum lateral dimension is within a range of about 0.075 to about 0.25.
15. A plastic container according to claim 14, wherein said ratio of said minimum width to said maximum lateral dimension is within a range of about 0.10 to about 0.20.
16. A plastic container according to claim 13, wherein each of said plurality of posts is tapered as viewed in side elevation.
17. A plastic container according to claim 16, wherein each of said plurality of posts has a mid portion, an upper distal portion and a lower distal portion, and is shaped so as to be wider

when viewed in side elevation at said mid portion than at at least one of said upper and lower distal portions.

18. A plastic container according to claim 17, wherein each of said plurality of posts is shaped so as to be wider when viewed in side elevation at said mid portion than at both of said upper and lower distal portions.

19. A plastic container according to claim 13, wherein said sidewall further comprises a discontinuity extending circumferentially about a longitudinal mid portion of said container body.

20. A plastic container according to claim 19, wherein said discontinuity comprises a groove defined in said sidewall.

21. A plastic container according to claim 20, wherein said groove is substantially octagonal as viewed in transverse cross section.

22. A plastic container according to claim 13, wherein each of said plurality of flexible panels is generally hourglass-shaped.

23. A plastic container according to claim 13, wherein a ratio of said maximum width to said maximum lateral dimension is within a range of about 0.15 to about 0.45.

24. A plastic container that is adapted for adjustment to internal volumetric changes, comprising:

a container body defining an internal space, said container body having a maximum lateral dimension and a sidewall comprising a plurality of flexible panels and a corresponding plurality of posts, said posts being respectively interposed between said flexible panels;

wherein each of said plurality of posts has a maximum width, and wherein a ratio of said maximum width to said maximum lateral dimension is within a range of about 0.15 to about 0.45.

25. A plastic container according to claim 24, wherein said ratio of said maximum width to said maximum lateral dimension is within a range of about 0.175 to about 0.40.

26. A plastic container according to claim 25, wherein said ratio of said maximum width to said maximum lateral dimension is within a range of about 0.20 to about 0.35.
27. A plastic container according to claim 24, wherein each of said plurality of posts is tapered as viewed in side elevation.
28. A plastic container according to claim 27, wherein each of said plurality of posts has a mid portion, an upper distal portion and a lower distal portion, and is shaped so as to be wider when viewed in side elevation at said mid portion than at at least one of said upper and lower distal portions.
29. A plastic container according to claim 28, wherein each of said plurality of posts is shaped so as to be wider when viewed in side elevation at said mid portion than at both of said upper and lower distal portions.
30. A plastic container according to claim 24, wherein said sidewall further comprises a discontinuity extending circumferentially about a longitudinal mid portion of said container body.
31. A plastic container according to claim 30, wherein said discontinuity comprises a groove defined in said sidewall.
32. A plastic container according to claim 31, wherein said groove is substantially octagonal as viewed in transverse cross section.
33. A plastic container according to claim 24, wherein each of said plurality of flexible panels is generally hourglass-shaped.

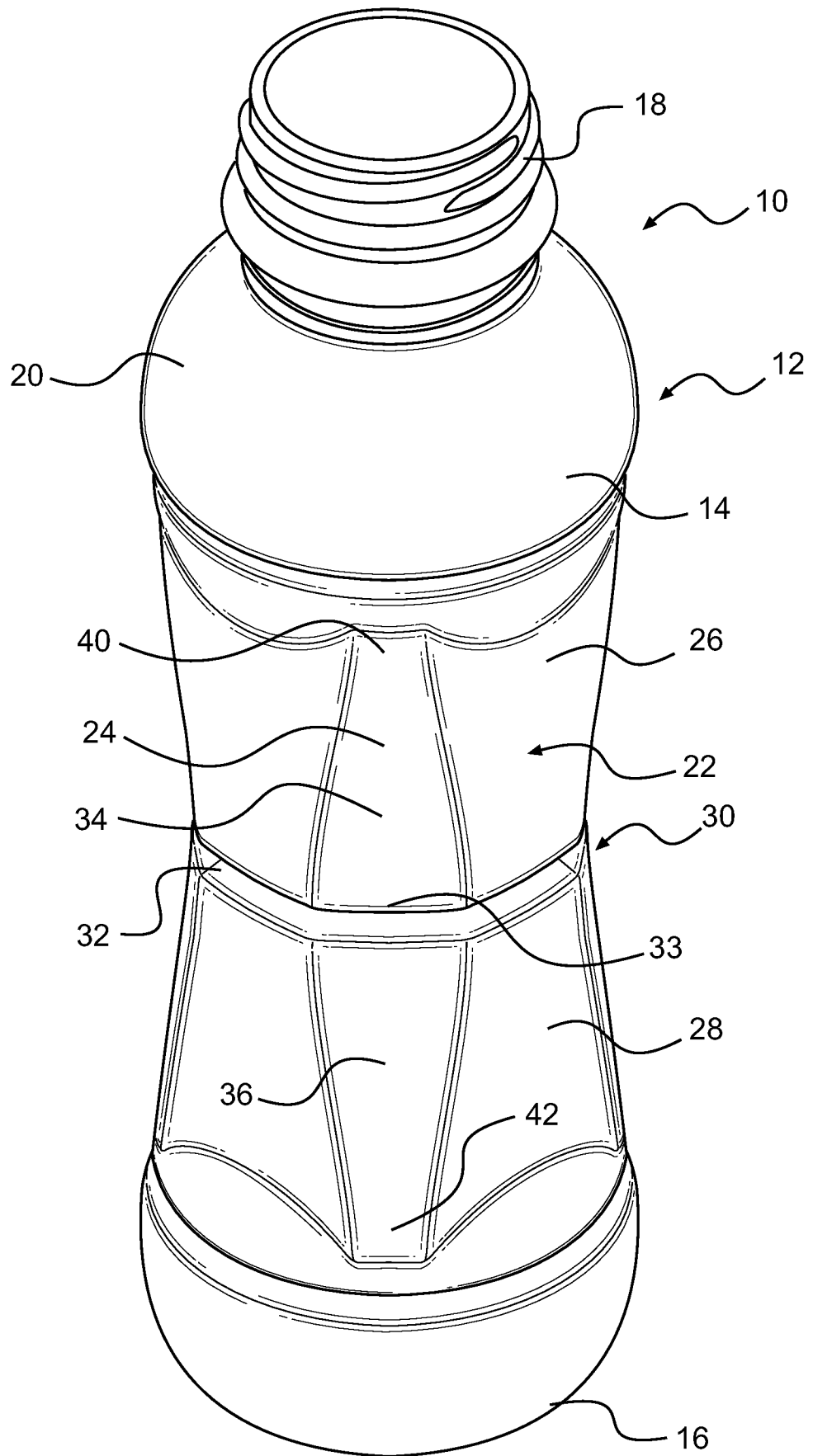

FIG. 1

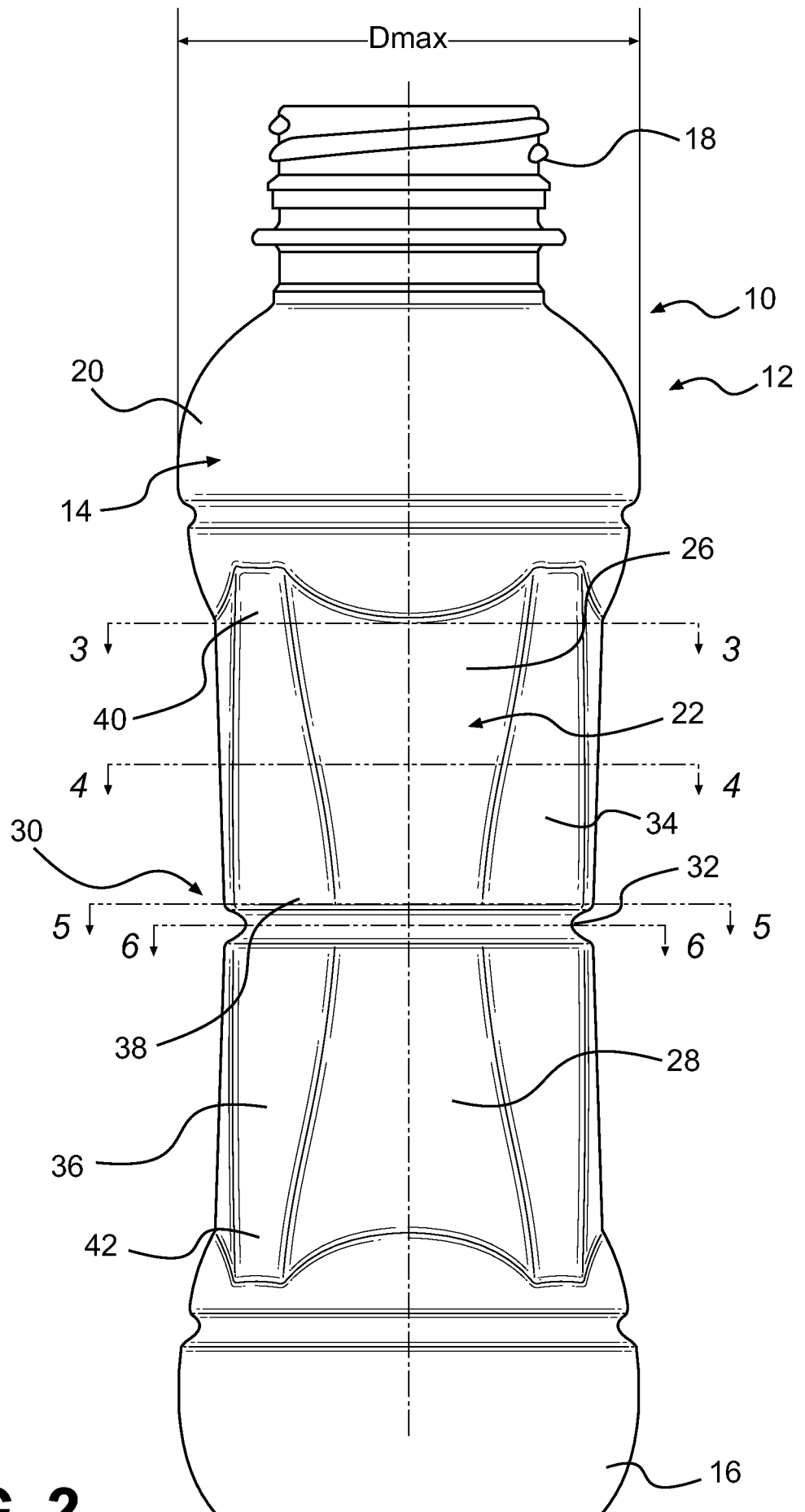

FIG. 2

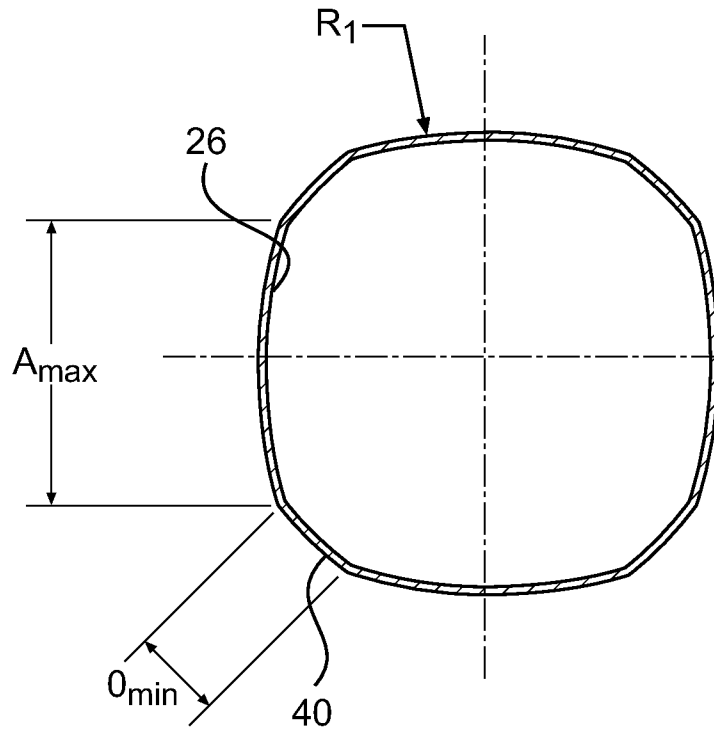

FIG. 3

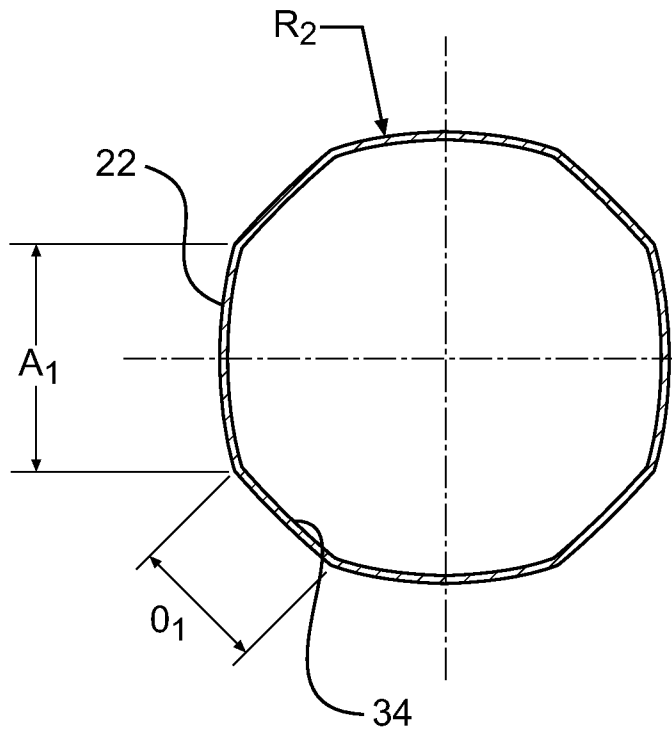

FIG. 4

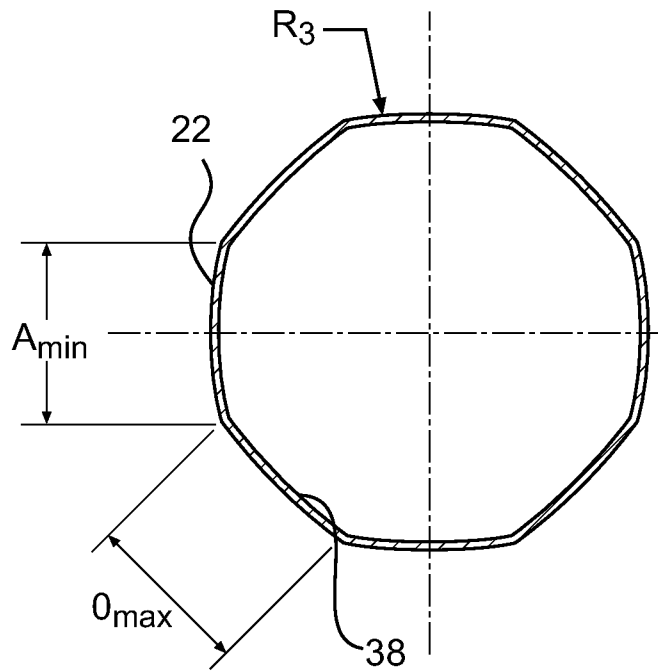

FIG. 5

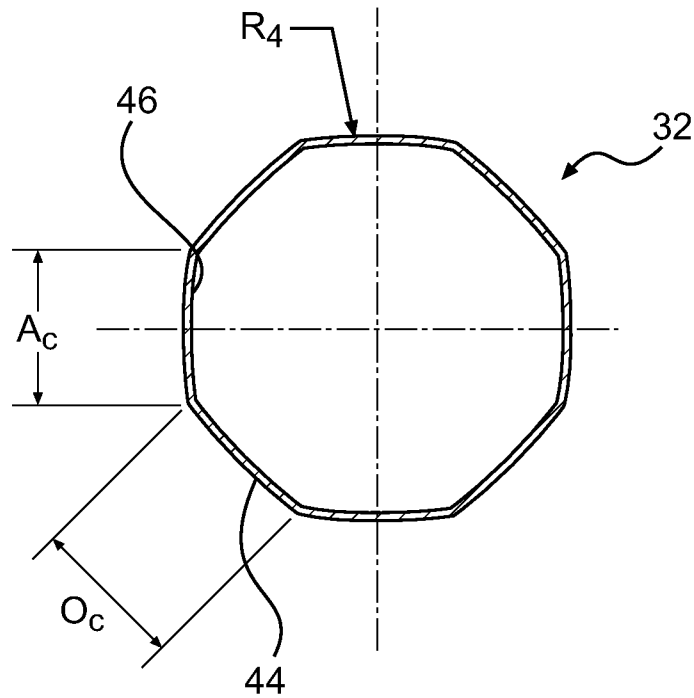

FIG. 6

INTERNATIONAL SEARCH REPORT

International application No
PCT/US2010/054460

A. CLASSIFICATION OF SUBJECT MATTER
 INV. B65D1/02 B65D79/00
 ADD.
 According to International Patent Classification (IPC) or to both national classification and IPC

B. FIELDS SEARCHED
 Minimum documentation searched (classification system followed by classification symbols)
 B65D

Documentation searched other than minimum documentation to the extent that such documents are included in the fields searched

Electronic data base consulted during the international search (name of data base and, where practical, search terms used)
 EPO-Internal

C. DOCUMENTS CONSIDERED TO BE RELEVANT

Category*	Citation of document, with indication, where appropriate, of the relevant passages	Relevant to claim No.
X	US 2008/041811 A1 (STOWITTS ADAM P S [US]) 21 February 2008 (2008-02-21) paragraph [0016] - paragraph [0020]; figures	1-33
X	US 2008/041812 A1 (STOWITTS ADAM P S [US]) 21 February 2008 (2008-02-21) paragraphs [0013] - [0018]; figures	1-33
X	US 2006/186082 A1 (GATEWOOD ERIK E [US] ET AL) 24 August 2006 (2006-08-24) paragraph [0015]; figures	13-15, 23

Further documents are listed in the continuation of Box C. See patent family annex.

* Special categories of cited documents :

A document defining the general state of the art which is not considered to be of particular relevance	*T* later document published after the international filing date or priority date and not in conflict with the application but cited to understand the principle or theory underlying the invention
E earlier document but published on or after the international filing date	*X* document of particular relevance; the claimed invention cannot be considered novel or cannot be considered to involve an inventive step when the document is taken alone
L document which may throw doubts on priority claim(s) or which is cited to establish the publication date of another citation or other special reason (as specified)	*Y* document of particular relevance; the claimed invention cannot be considered to involve an inventive step when the document is combined with one or more other such documents, such combination being obvious to a person skilled in the art.
O document referring to an oral disclosure, use, exhibition or other means	*Z* document member of the same patent family
P document published prior to the international filing date but later than the priority date claimed	

Date of the actual completion of the international search 11 January 2011	Date of mailing of the international search report 19/01/2011
--	--

Name and mailing address of the ISA/ European Patent Office, P.B. 5818 Patentlaan 2 NL - 2280 HV Rijswijk Tel. (+31-70) 340-2040, Fax: (+31-70) 340-3016	Authorized officer Fournier, Jacques
--	---

INTERNATIONAL SEARCH REPORT

Information on patent family members

International application No
PCT/US2010/054460

Patent document cited in search report	Publication date	Patent family member(s)	Publication date
US 2008041811	A1	21-02-2008	NONE
US 2008041812	A1	21-02-2008	NONE
US 2006186082	A1	24-08-2006	NONE