

(No Model.)

J. H. MORIN.
LOOM SHUTTLE.

No. 525,814.

Patented Sept. 11, 1894.

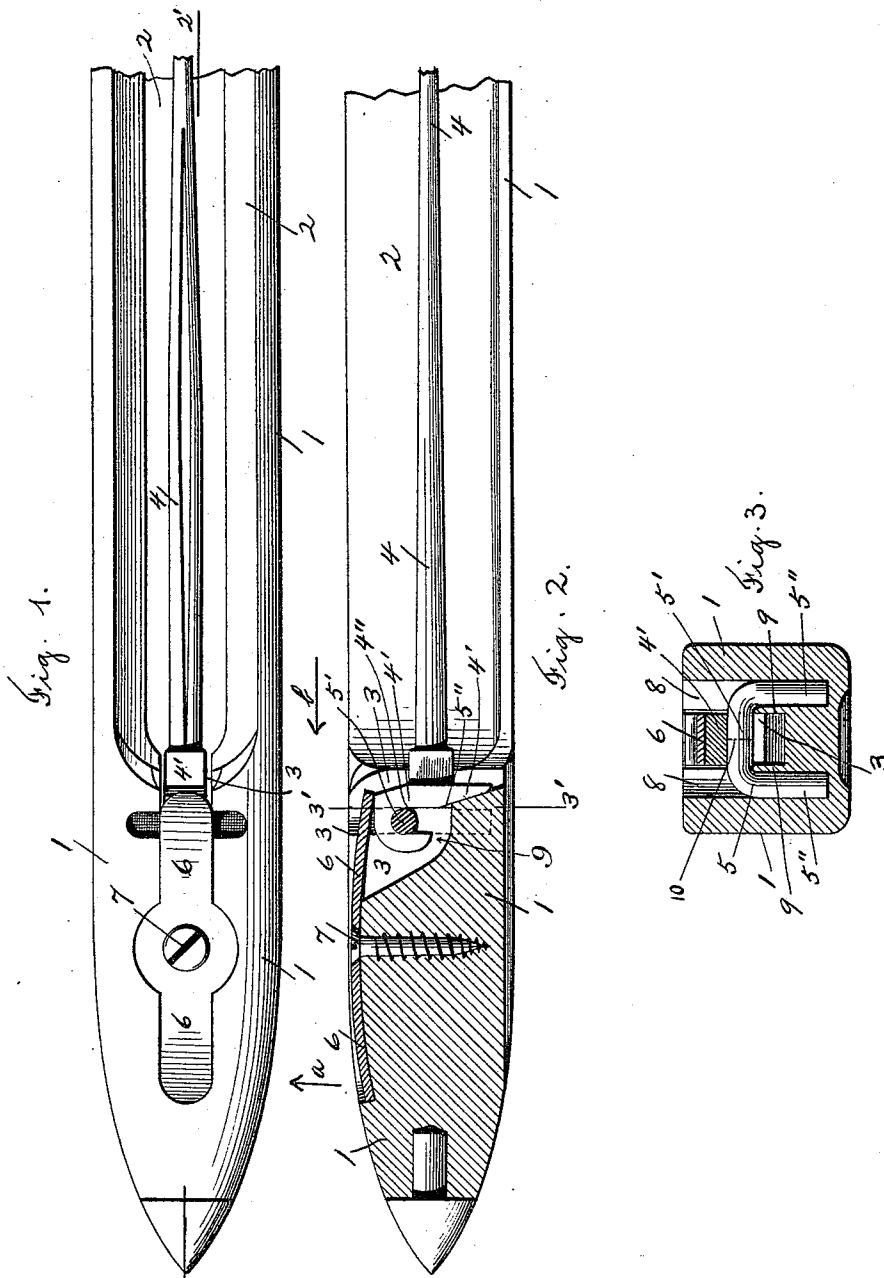

Witnesses
Chas. F. Johnson
H. Farrell

Inventor
J. H. Morin,
By Attorney
John C. Dewey.

UNITED STATES PATENT OFFICE.

JOSEPH H. MORIN, OF WILKINSONVILLE, MASSACHUSETTS.

LOOM-SHUTTLE.

SPECIFICATION forming part of Letters Patent No. 525,814, dated September 11, 1894.

Application filed April 20, 1894. Serial No. 508,277. (No model.)

To all whom it may concern:

Be it known that I, JOSEPH H. MORIN, a citizen of the United States, residing at Wilkinsonville, in the county of Worcester and State of Massachusetts, have invented certain new and useful Improvements in Loom-Shuttles; and I do hereby declare that the following is a full, clear, and exact description thereof, which, in connection with the drawings making a part of this specification, will enable others skilled in the art to which my invention belongs to make and use the same.

My invention relates to loom shuttles, and more particularly to the manner of attaching the spindle to the shuttle body.

Heretofore in loom shuttles, the heel or base of the spindle has ordinarily been pivotally attached to the shuttle body, within a cavity or recess at one end thereof, to be raised, or moved down in a horizontal position, by a pin extending transversely through the shuttle body, and through a hole or opening in the heel or base of the spindle. This pin is liable to work loose, and the headed end thereof will project beyond the plain surface of the shuttle, and come in contact with and catch the filling, as the shuttle passes back and forth on the lay; and further, the pin on which the spindle is pivoted may work loose, and become detached from the shuttle, and in substituting another pin and driving the same into the shuttle to act as a pivot for the spindle, the shuttle is liable to be split, or cracked, in case the pin is a little larger than the pin previously used.

The object of my invention is to overcome the objections mentioned above to the ordinary way of pivoting the spindle in the shuttle body, and to do away with the pivot pin extending transversely through the shuttle body, and to provide in place thereof, an attaching device consisting of a staple, the two legs of which extend at right angles to the top of the staple, and are inserted into holes or recesses formed in the shuttle body, and the top of which forms the pivot pin, with which the heel or base of the spindle engages; said spindle heel or base being held in engagement with said staple, to have a pivotal motion thereon, by a flat heel spring, of ordinary construction.

My invention consists in certain novel fea-

tures of construction of a loom shuttle, as will be hereinafter fully described, and the nature thereof indicated by the claims.

Referring to the drawings:—Figure 1 is a top view of a portion of a loom shuttle embodying my improvements. Fig. 2 is a central longitudinal section, on line 2', 2', Fig. 1, looking in the direction of arrow *a*, same figure, and Fig. 3 is a cross section, on line 3', 3', Fig. 2, looking in the direction of arrow *b*, same figure.

In the accompanying drawings, 1 is the shuttle body, of the usual form, provided with the cop chamber 2, and the recess 3 at one end thereof, within which recess is pivoted the heel or base 4' of the spindle 4. The heel or base 4' of the spindle 4 is provided in this instance with an open end slot 4'', which engages with, and has a pivotal motion on the top or cross bar 5' of the staple 5.

One end of the flat heel spring 6, which extends in a recess in the top of the shuttle body, at one end thereof, and is secured therein by a screw 7, projects over the heel or base 4' of the spindle 4, as shown in Fig. 2, to hold the spindle in place when closed down in a horizontal position within the cop chamber of the shuttle, and also to hold the spindle in place when raised to remove, or place the cop thereon, in the ordinary way.

The device 5 on which the heel or base of the spindle is pivoted is preferably made staple shape, as shown in Fig. 3 of the drawings, and consists of the top or connecting bar 5' extending transversely in the shuttle body, and the two legs or ends 5'', extending at right angles to the top or connecting bar 5'. The legs 5'' extend in vertical holes or openings 8, bored in the shuttle body, at a point where the recess 3 extends therein, and two divisions 9 extend between the legs 5'' of the staple 5, at each side of the heel or base 4' of the spindle 4, and said heel or base extends between said divisions, as shown in Fig. 3.

The open end slot 4'' in the heel or base 4', of the shuttle 4, extends over the top or cross bar 5' of the staple 5, and is held in engagement therewith, to have a pivotal motion thereon, as the spindle is raised out of the shuttle body, or lowered therein, by the flat heel spring 6, as shown in Fig. 2.

The advantages of my improved construction of loom shuttles will be readily appreciated by those skilled in the art.

I do away with the ordinary pivot pin extending transversely through the shuttle body, with its head extending through one side thereof, and I provide an attachment for the spindle, which is located entirely within the shuttle body, and which is inserted from the top of the shuttle. By my construction of the spindle pivot, making it of staple shape extending into two vertical holes or recesses within the body of the shuttle, I hold together the sides of the shuttle, at the point where the recess extends for the reception of the spindle heel or base, and thus strengthen the shuttle, and prevent its splitting.

It will be understood that the details of construction of my improvements may be varied somewhat, if desired.

I have shown in the drawings the heel or base of the spindle provided with an open end slot, but I do not limit myself to this construction, as the heel or base may have the ordinary transverse hole, extending through the same, in which case my staple may be cut in two, through the bar 5', as indicated by dotted line 10, Fig. 3, and each half of the bar 5', inserted in the hole of the heel or base of the spindle, from each side thereof, and the legs 5'' inserted into the recesses 3, and the base or heel of the spindle into the cavity 3, and the staple pressed into position,

to hold the spindle in pivotal connection with the shuttle body, in the same manner as though the staple was made in one piece.

Having thus described my invention, what I claim as new, and desire to secure by Letters Patent, is—

1. The combination with a shuttle body and a spindle, of means for pivotally attaching the heel or base of the spindle, to the shuttle body, consisting of a staple, the top of which forms a transverse bearing, which is engaged by the heel or base of the spindle, and the legs or ends of which extend at right angles to the top, and enter vertical holes or openings in the shuttle body, at each side of the heel of the spindle, substantially as shown and described.

2. In a loom shuttle, the combination with a shuttle body, and a spindle, having the heel or base thereof provided with an open end slot, of a staple, having the ends thereof extended into holes or recesses in the shuttle body, at right angles to the top of the staple, the top of said staple being engaged by the heel or base of the spindle, and a heel spring, bearing on the heel or base of the spindle to hold the same in engagement with the staple, substantially as shown and described.

JOSEPH H. MORIN.

Witnesses:

JOHN C. DEWEY,
KATIE FARRELL.