

G. NEUFELD.  
BOBBIN CARRIER.  
APPLICATION FILED MAY 14, 1906.

998,031.

Patented July 18, 1911.

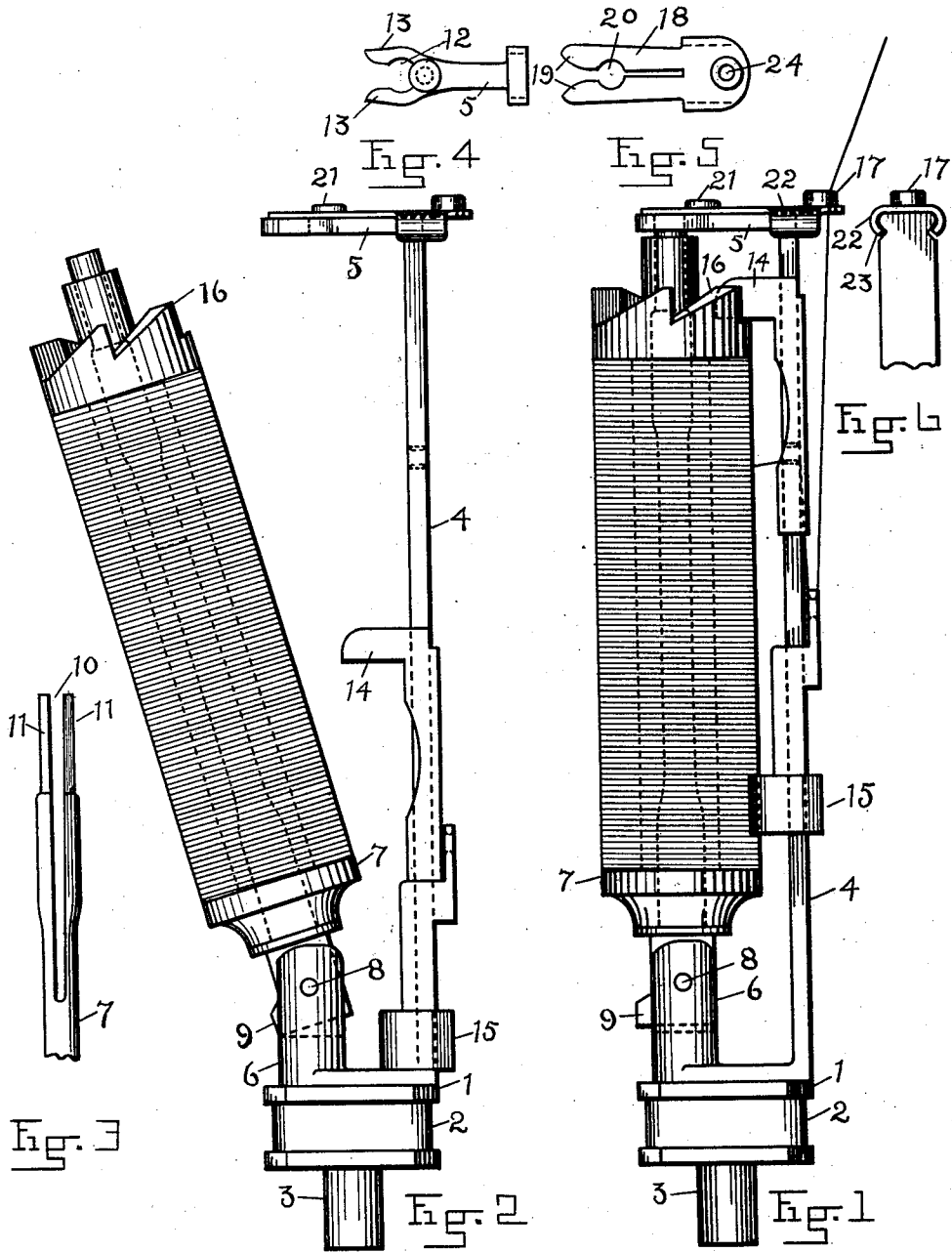

WITNESSES  
*Catherine S. Bradley*  
*James H. Thurston*

INVENTOR  
*George Neufeld,*  
By *Wilmarth & Thurston*  
ATTY

# UNITED STATES PATENT OFFICE.

GEORGE NEUFELD, OF PHILADELPHIA, PENNSYLVANIA, ASSIGNOR TO NEW ENGLAND BUTT COMPANY, OF PROVIDENCE, RHODE ISLAND, A CORPORATION OF RHODE ISLAND.

## BOBBIN-CARRIER.

998,031.

Specification of Letters Patent.

Patented July 18, 1911.

Application filed May 14, 1906. Serial No. 316,615.

### *To all whom it may concern:*

Be it known that I, GEORGE NEUFELD, of Philadelphia, county of Philadelphia, and State of Pennsylvania, have invented certain new and useful Improvements in Bobbin-Carriers; and I do hereby declare the following specification, taken in connection with the accompanying drawings, forming a part of the same, to be a full, clear, and exact description thereof.

The invention relates to bobbin-carriers for braiding machines, and has for its object to provide a structure in which the bobbin may be readily applied and removed and in which the sliding pawl and tension weight may likewise be readily removed and replaced, but will also be held against accidental displacement in the working of the machine.

One feature of invention consists in providing a hinged spindle for the bobbin, with means for normally holding the spindle and bobbin in proper vertical position, the construction being such that the bobbin and spindle may be tipped to one side, and so that an empty bobbin may be removed from the spindle and a new bobbin placed thereon.

A further feature of invention consists in providing a detachable thread-guide which in its normal position will serve to prevent the removal or displacement of the sliding pawl and tension weight, but which may be readily detached from the carrier and so as to permit the removal of said tension weight and pawl when it is desired to substitute others therefor.

The invention further consists in certain features of construction hereinafter described and claimed.

Referring to the drawings, Figure 1 represents in side elevation a bobbin-carrier embodying the invention with a bobbin in place therein; Fig. 2 is a corresponding view showing the bobbin and spindle tipped to one side to permit the bobbin to be removed from the spindle; Figs. 3, 4 and 5 are detail views to be hereinafter referred to.

In the drawings 1 represents the base of

the carrier provided with the usual groove 2 for engaging the raceway of the braiding machine and the stud 3 by which the carrier is moved by its operative devices. Projecting upward from the base 1 is the tension weight standard 4 provided at its upper end with a horizontal arm 5. Also projecting upward from the base 1 is a short standard 6 in which the spindle 7 is pivoted or hinged. In the construction shown in the drawings this standard 6 is provided with a vertical slot, and the lower end of the spindle is made flat so as to enter this slot, and is connected to the ears of the standard formed by said slot by a pivot or hinge-pin 8. The lower end of the spindle is located somewhat above the lower end of the slot in the standard, as indicated in dotted lines in Fig. 1, so as to permit the necessary tipping of the spindle. The outer corner of the flattened lower end of the spindle, which is preferably extended somewhat to form a toe 9, constitutes a stop to limit the extent to which the spindle may tip, as shown in Fig. 2.

The upper end of the spindle is provided with a slot 10 to form spring fingers 11, as shown in Fig. 3, and the outer end of the horizontal arm 5 is forked and provided with an opening 12, as shown in Fig. 4, to receive the spring fingers 11 formed at the upper end of the spindle. The fingers 13 at the forked end of the arm 5 are constructed substantially as shown in Fig. 4, that is, are of a wedge-shape at their outer ends and with the space between said fingers, which forms the passage leading to the opening 12, less than the diameter of the split upper end of the spindle 7. With this construction when the split upper end of the spindle is forced between the wedge shaped outer ends of the fingers 13, the spring fingers 11 of the spindle will be pressed together, setting up a spring force therein, and so that when said fingers have passed into the circular opening 12 they will spring apart into their normal position and so as to be embraced by the fingers 13 of the arm 5, and the spindle will be thereby held in

its proper vertical position until a sufficient force is applied to withdraw it from the embrace of the fingers 13. As will be seen, with the fingers 13 shaped as shown a considerable force will require to be exerted in a direction to pull the upper end of the spindle out of the opening 12, and the spindle will consequently be held in position against any accidental displacement.

10 The sliding pawl 14 and the tension weight 15 are of the usual construction and are mounted on the standard 4 in the usual manner, the sliding pawl being adapted to engage the ratchet 16 formed on the upper end of the bobbin as usual.

15 The thread-guide 17 is in the form of a spring clip adapted to be removably secured in place on the horizontal arm 5. This thread-guide is preferably constructed of sheet metal and is forked or slotted to form spring fingers 18. These fingers 18 are provided at their outer ends with wedge-shaped portions 19, and with a space between them forming a contracted passage leading to an opening 20 adapted to receive the shank of a headed stud 21 secured to the horizontal arm 5. Preferably the thread-guide is also provided with side wings or clips 22 which are bent inward and adapted to engage undercut recesses 23 formed in the sides of the standard 4, as shown in Fig. 6. At its outer end the thread-guide is provided with the usual guide-eye 24. The thread-guide is placed in position by sliding the same along the upper surface of the horizontal arm 5 until the shank of the stud 21 is brought into the opening 20. In doing this the spring-fingers 18 will be forced apart by the engagement of the wedge-shaped portions 19 with the shank of the stud 21, thereby setting up a spring force in said fingers. When the shank of said stud has passed into the circular opening 20, the spring fingers will return to their normal position and so as to substantially embrace said stud. With this construction, as will be seen, the thread-guide will be removably held in position against longitudinal displacement by the engagement of the spring fingers 18 with the stud 21, and will likewise be removably held against vertical displacement by the head of the stud 21 and also by the engagement of the wings 22 with the undercut recesses 23. It will be further seen that as long as the thread-guide remains in position the outer projecting end thereof will constitute a barrier against the removal or accidental displacement of the sliding pawl and tension weight. Whenever it is desired to remove said pawl and weight for the purpose of substituting others or otherwise, all that is necessary to be done is simply to withdraw and remove the thread-guide, when said pawl and weight may be

slipped up off of the standard 4. When the proper pawl and weight have been placed upon the standard, the thread-guide is again slipped into position, and will serve to hold them against displacement.

It will be observed that with the above construction the bobbin is not supported between top and bottom bearings, but is instead supported and held by the spindle 7 which passes through the bobbin, the horizontal arm 5 serving simply to hold the hinged spindle in proper vertical position.

While I have shown the spindle as provided with spring fingers to engage the forked end of the horizontal arm, it will be understood that, if desired, instead of thus providing the spindle with such spring fingers the fingers 13 of the horizontal arm may be made spring fingers, and so as to spring about the upper end of the spindle which in such case may be made solid.

What I claim as my invention and desire to secure by Letters Patent is:

1. A bobbin-carrier comprising a base, a standard projecting upward therefrom and provided with a horizontal arm, a spindle hinged to said base and having its upper end provided with spring fingers, said horizontal arm being forked and adapted to engage and hold the end of said spindle, substantially as described.

2. A bobbin-carrier comprising a base, a standard projecting upward therefrom and provided with a horizontal arm, and a thread-guide adapted to be slidably detached from said horizontal arm, substantially as described.

3. A bobbin-carrier comprising a base, a standard projecting upward therefrom and provided with a horizontal arm, and a thread-guide adapted to be slidably detached from said horizontal arm with its end overhanging said standard, substantially as described.

4. A bobbin-carrier comprising a base, a standard projecting upward therefrom and provided with a horizontal arm, a tension weight and pawl slidably mounted on said standard, and a thread-guide removably attached to said horizontal arm with its end overhanging said standard to prevent accidental displacement of said pawl and weight, substantially as described.

5. A bobbin-carrier comprising a base, a standard projecting upward therefrom and provided with a horizontal arm, and a thread-guide provided with spring fingers adapted to engage a projection on said horizontal arm, substantially as described.

6. A bobbin-carrier comprising a base, a standard projecting upward therefrom and provided with a horizontal arm, a thread-guide slidably detachable from said horizontal arm, and interlocking means to nor-

mally hold said thread-guide against lateral and vertical displacement, substantially as described.

5 7. A bobbin-carrier comprising a base, a standard projecting upward therefrom and provided with a horizontal arm, and a thread-guide provided with spring fingers to engage a projection on said horizontal

arm and with side wings to engage undercut recesses in said standard, substantially as 10 described.

GEORGE NEUFELD.

Witnesses:

JAS. B. WOOD,  
OTTO F. STRUCK.

Copies of this patent may be obtained for five cents each, by addressing the "Commissioner of Patents, Washington, D. C."