

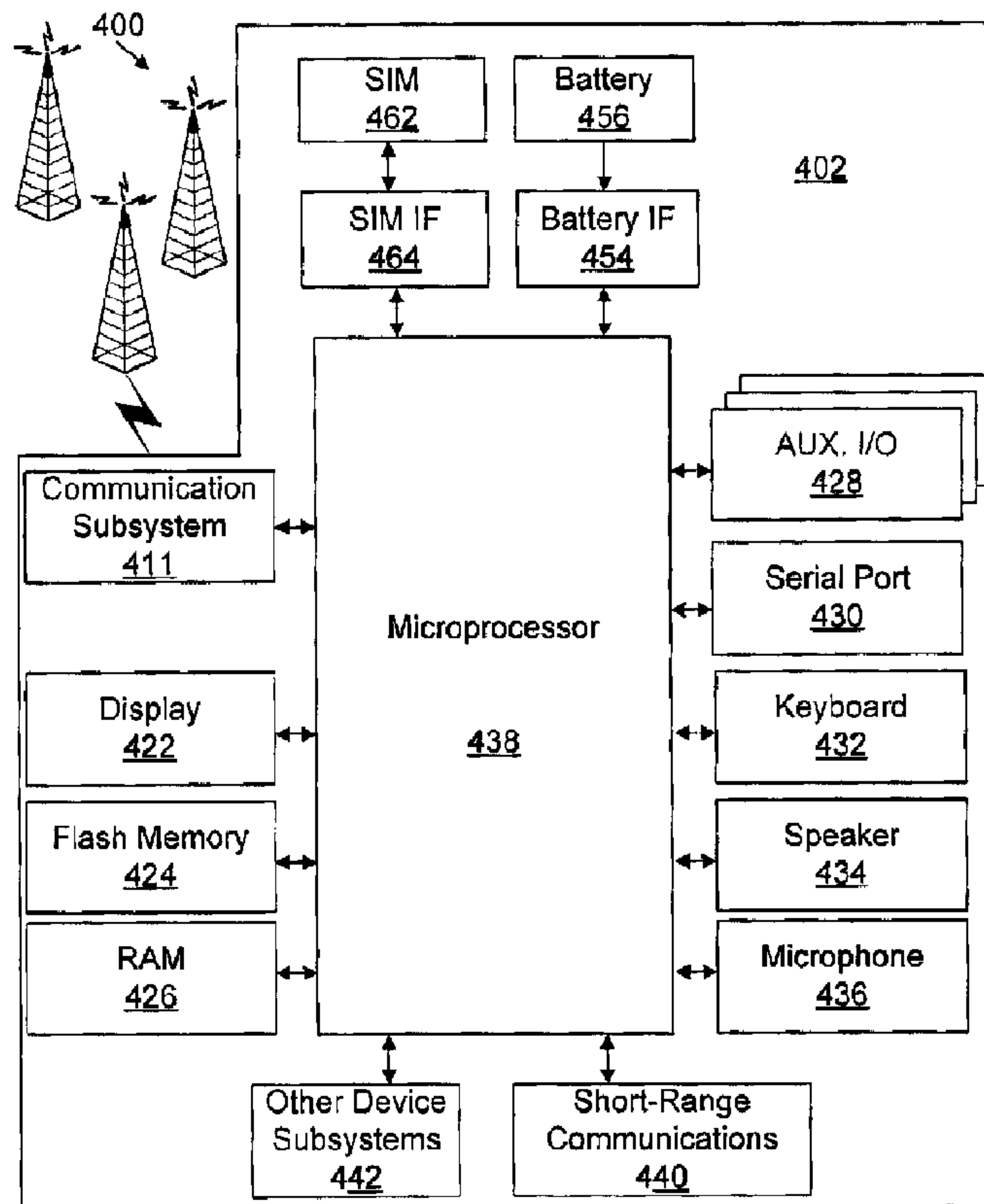

(22) Date de dépôt/Filing Date: 2006/05/29
 (41) Mise à la disp. pub./Open to Public Insp.: 2007/01/28
 (45) Date de délivrance/Issue Date: 2013/12/17
 (30) Priorité/Priority: 2005/07/28 (EP05107004.3)

(51) Cl.Int./Int.Cl. *H04M 3/54* (2006.01)
 (72) Inventeurs/Inventors:
 ADAMS, NEIL, CA;
 VANDER VEEN, RAYMOND, CA
 (73) Propriétaire/Owner:
 RESEARCH IN MOTION LIMITED, CA
 (74) Agent: NORTON ROSE FULBRIGHT CANADA
 LLP/S.E.N.C.R.L., S.R.L.

(54) Titre : METHODE ET SYSTEME POUR RENVOYER DES APPELS ETABLIS AVEC UNE DESTINATION DE TELECOMMUNICATIONS
 (54) Title: METHOD AND SYSTEM FOR FORWARDING CALLS PLACED TO A TELECOMMUNICATIONS DESTINATION



(57) **Abrégé/Abstract:**

A method and system for forwarding calls placed to a primary destination is provided. The method comprises: receiving at least one call forwarding profile, each call forwarding profile having a predefined duration and at least one call forwarding destination; receiving an instruction to activate one call forwarding profile; and forwarding calls placed to the telecommunications destination according to the activated profile.



ABSTRACT

A method and system for forwarding calls placed to a primary destination is provided. The method comprises: receiving at least one call forwarding profile, each call forwarding profile having a predefined duration and at least one call forwarding destination; receiving an instruction to activate one call forwarding profile; and forwarding calls placed to the telecommunications destination according to the activated profile.

METHOD AND SYSTEM FOR FORWARDING CALLS PLACED TO A TELECOMMUNICATIONS DESTINATION

FIELD OF APPLICATION

[0001] This application relates to the field of telecommunications and more particularly to methods of call forwarding within a communications network.

BACKGROUND

[0002] Mobile telecommunications devices are becoming more and more ubiquitous because they help users to communicate with the world. The popular PDA can function as a mobile or cellular phone, fax sender, and personal organizer. A PDA is a handheld mobile device that allows users to access information, keep track of their busy schedules, and communicate with others. Furthermore, many PDAs are capable of wireless connectivity and executing any number of software applications. It is very important for today's mobile professional to be able to effectively communicate with others from anywhere in the world.

[0003] Call forwarding is a common feature of both wired and wireless phones. The purpose of call forwarding is to route a call placed to a first calling destination, typically represented by a first phone number, to a second calling destination. There are numerous reasons a user may want to forward calls from the first calling destination to the second calling destination. For example, the phone representing the first calling destination may be low on battery or the user wants to forward calls placed to a wireless phone to a wired phone in order to save on wireless air-time costs.

[0004] Methods are known which allow a user to forward calls placed to a first phone number to a another phone number. Typically, a user inputs a call forwarding code and a call forwarding destination into the first phone. Instructions regarding call forwarding are then sent to the service provider which then routes all calls placed to the first phone number to the call forwarding destination.

[0005] Methods are also known that allow users to schedule call forwarding to a particular call forwarding destination to occur at a future time. These methods, however, often require the user to continually update the schedule on a going forward basis.

[0006] Methods for forwarding calls to a telecommunications device having an improved ease of use are desired.

SUMMARY

[0007] In accordance with one aspect of the present application, there is provided a method for forwarding calls placed to a primary destination, comprising: receiving at least one call forwarding profile, each call forwarding profile having a predefined duration and at least one call forwarding destination; receiving an instruction to activate one call forwarding profile to an activated profile; and forwarding calls placed to the telecommunications destination according to the activated profile.

[0008] In accordance with another aspect of the present application, there is provided a system for forwarding calls placed to a primary destination, comprising: a processor operatively connected to a memory, the memory including data and instructions to configure the processor to: receive at least one call forwarding profile, each call forwarding profile having a predefined duration and at least one call forwarding destination; receive an instruction to activate one call forwarding profile to an activated profile; and forward calls placed to the telecommunications destination according to the activated profile.

[0009] In accordance with another aspect of the present application, there is provided a computer readable memory storing statements and instructions which when executed causes the performance of the methods of the application.

[0010] In accordance with another aspect of the present application, there is provided a data carrier product containing sequences of instructions which when executed causes the performance of the methods of the application.

[0011] In accordance with another aspect of the present application, there is provided a software product containing sequences of instructions which when executed causes the performance of the methods of the application.

[0012] In accordance with another aspect of the present application, there is provided an integrated circuit product containing sequences of instructions which when executed causes the performance of the methods of the application.

[0013] In accordance with another aspect of the present application, there is provided a memory for storing data for access by an application program being executed on a data processing system, comprising a data structure for a call forwarding profile stored in said memory, the data structure comprising call data comprising destination data representing at least one call forwarding destination, duration data representing a duration of the call forwarding profile and initiation data corresponding to a trigger for activating the call forwarding profile.

[0014] In accordance with further aspects of the present application, there is provided an apparatus such as a mobile telecommunications device, a method for adapting this mobile telecommunications device, as well as articles of manufacture such as a pre-recorded storage device or other computer readable medium having program instructions recorded thereon for practising the method of the application, as well as a computer data signal carrying computer readable program instructions for practising the method of the application.

[0015] These and other aspects and features of the present application will become apparent to persons of ordinary skill in the art upon review of the following detailed description, taken in combination with the appended drawings.

BRIEF DESCRIPTION OF THE DRAWINGS

[0016] Figure 1 is a flowchart illustrating operations for forwarding calls placed to a telecommunications device according to a first embodiment of the application;

[0017] Figure 2 is a flowchart illustrating operations for forwarding calls placed to a telecommunications device according to a second embodiment of the application;

[0018] Figure 3 is a schematic showing a data structure for a call forwarding profile; and

[0019] Figure 4 shows a mobile telecommunications device having a memory for storing the data structure of the present application.

[0020] It will be noted that throughout the appended drawings, like features are identified by like reference numerals.

DESCRIPTION OF PREFERRED EMBODIMENTS

[0021] According to one broad aspect of the application, there is provided a method for forwarding calls placed to a primary destination comprising receiving at least one call forwarding profile, each call forwarding profile having a predefined duration and at least one call forwarding destination, receiving an instruction to activate one call forwarding profile, and forwarding calls placed to the telecommunications destination according to the activated profile. Preferably, the at least one call forwarding destination is defined for a predetermined period of time.

[0022] Advantageously, the methods of the application provide for a user to define and store at least one call forwarding profile representing a desired call forwarding pattern. The user may then easily forward calls by activating the appropriate profile.

[0023] The advantages of the present application are further illustrated by examples. The examples and their particular details set forth herein are presented for illustration only and should not be construed as a limitation on the claims of the present application.

[0024] Generally, in accordance with an aspect of the application, there is provided methods of forwarding calls placed to a primary destination within a telecommunications network that is wired, wireless or a combination thereof. The primary destination may be any telecommunications destination and is typically represented by a telephone number. Calls placed to a telecommunications destination may be answered using a telecommunications device, such as a telephone or mobile phone, coupled to communicate with the telecommunications network, preferably wirelessly. It will be understood by a

person skilled in the art that although the embodiments of the present application are described largely with respect to telephone numbers and telephone destinations, a telecommunications destination may be any destination capable of receiving data within a telecommunication network.

[0025] Referring to Figure 1, a flowchart illustrating operations 100 according to a first embodiment of the application is provided. At step 110, a call forwarding profile is received. The call forwarding profile has a predefined duration and has at least one call forwarding destination. The call forwarding destination is the desired telecommunications destination to which calls, placed to the primary destination, will be forwarded. The call forwarding profile preferably also comprises a predetermined time period associated with the call forwarding destination, the predetermined time being and in the course of the duration of the call forwarding profile.

[0026] If an instruction is received to activate the call forwarding profile at step 120, at step 130, the call forwarding profile is activated to an activated profile. At step 140, calls to the primary destination are forwarded according to the activated profile.

[0027] An example of a work call forwarding profile is shown below as Example 1.

Example 1 – work profile

number 1: (555) 555-1111 (work) Time of Day: 9:00 (Day 1) – 12:00 (Day 1)

number 2: (555) 555-1111 (work) Time of Day: 13:00 (Day 1) – 17:00 (Day 1)

number 3: (555) 555-2222 (home) Time of Day: 18:00 (Day 1) – 8:00 (Day 2) 25

Duration: terminate 24 hours from activation

[0028] This Example 1 work profile may represent a call forwarding profile for a user who has a mobile phone and a mobile number, representing the primary destination, and a nine to five desk job. Preferably, the user inputs the work profile through an interface on the mobile phone and the work profile is then stored on a memory resident on the mobile phone.

The work profile has a duration of 24 hours and within that 24 hour period, there are three call forwarding destinations defined for three predetermined time periods. The user may activate the work profile through the interface on the user's mobile phone resulting in the telecommunications network forwarding calls placed to the primary destination according to the activated work profile. Therefore, if the user activates the profile when driving to work at 8:30 Monday morning, the instruction is then given to the telecommunications network to forward calls according to the activated work profile. The telecommunications network compares the present time, 8:30, to the work profile and determines that there is no call forwarding destination defined for 8:30. Thus, calls to the mobile number will continue to be placed to the mobile device. At 9:00, until 12:00, calls to the mobile number are forwarded by the telecommunications network to the user's telephone at the user's desk at work, (555) 555-1111. At 12:00, calls to the user's mobile number cease to be forwarded until 13:00, at which time calls are again forwarded to the user's desk until 17:00. At 17:00, calls are again un-forwarded as the user leaves work and begins to drive home. At 18:00, when the user typically arrives home, calls to the user's mobile phone are forwarded to the user's home telephone until 8:00 the next morning. As the duration of the profile is 24 hours, the activated profile may terminate 24 hours after activation (at 8:30 the next day).

[0029] In another embodiment of the application, the call forwarding profile may include a termination time regardless of the duration. Therefore even though the above work profile has a duration of 24 hours, a user may define a termination time of 23:00 on Day 2. Therefore, no matter what time the profile is activated (whether at 8:30 or 23:01), it will shut off at 23:00 on Day 2.

[0030] In yet another embodiment of the application, an activated profile continues to cycle until terminated by the user. Referring to Figure 2, a flowchart illustrating operations 200 according to this embodiment of the application is provided. Operations 200 contain additional decision step 210. If the call forwarding profile is defined to be a repeating profile, at step 210 the profile is immediately restarted and calls are forwarded according to the call forwarding profile at step 140. For example, in respect of the work profile above, a user may activate the profile on Monday morning and the profile will cycle every 24 hours

resulting in the calls being forwarded according to the work profile daily until the profile is deactivated by the user, for example, on Friday night after the work week.

[0031] A call forwarding profile may also have a duration of longer than 24 hours. For example a weekend profile may be set as follows:

Example 2 – weekend profile

number 1: (555) 555-3333 (parents) Time of Day: 12:00 (Day 1) – 14:00 (Day 1)

number 2: (555) 555-2222 (home) Time of Day: 20:00 (Day 1) – 8:00 (Day 3)

Duration: Terminate at 8:01 on Day 3

[0032] In this Example 2, if a user activates the profile Saturday morning, calls to the user's mobile phone will be forwarded to the user's parent house at (555) 555-3333 from 12:00 to 14:00 on Day 1, namely Saturday, after which calls will not be forwarded until 20:00 that night. At 20:00 Saturday night, calls will be forwarded to the user's home until 8:00 on Day 3, namely Monday, at which time calls will un-forwarded and the profile deactivated one minute later at 8:01 on Monday.

[0033] Although Examples 1 and 2 comprise profiles defined by Day X, a person skilled in the art would understand that a call forwarding profile may comprise call forwarding destinations defined for a particular time of day for a particular day of the week as shown in the below Example 3.

Example 3 – weekend profile

number 1: (555) 555-3333 (parents) Time of Day: 12:00 (Saturday) – 14:00 20

(Saturday)

number 2: (555) 555-2222 (home) Time of Day: 20:00 (Saturday) – 8:00

(Monday)

Duration: Terminate at 8:01 on Monday

[0034] In another embodiment of the application, a call forwarding profile may comprise call forwarding destinations associated with not hours of the day but a predetermined time period following activation.

Example 4 – shift profile

number 1: (555) 555-1111 (work) Hour 0 Minute 0 – Hour 3 Minute 0 5

number 2: (555) 555-1111 (work) Hour 4 Minute 0 – Hour 8 Minute 0

Duration: Terminate at Hour 8 Minute 1

[0035] The shift profile of Example 4 may be particularly useful for shift workers that have a constantly changing start time for work, but once at work, the pattern of call forwarding desired by the user is predictable. In this instance, the user starts the call forwarding profile on beginning a work shift. According to the above shift profile, on activating the shift profile on beginning a work shift, calls to the user's mobile number are automatically forwarded by the telecommunications network to (555) 555-1111 for hours. Calls are then un-forwarded for 1 hour (between hours 3 and 4). At Hour 4, calls are forwarded to (555) 555-1111 for another four hours before un-forwarding the phone and deactivating the profile 8 hours and 1 minute after the shift profile was activated.

[0036] It will be understood by a person skilled in the art that a user may therefore input and store multiple call forwarding profiles and activate the appropriate profile at the appropriate time.

[0037] Although in the above examples, the trigger to activate a call forwarding profile is activation by a user, other triggers may be employed. Call forwarding profiles may therefore be set to activate automatically in response to the time of day, calendar date, day of the week, or a calendar hook such as an appointment entered into an electronic calendar.

[0038] Referring to Figure 3, according to another aspect of the application, a memory is provided for storing data for access by a call forwarding application being executed on a data processing system. The memory comprises a data structure 300 for a call forwarding profile 310 stored in the memory. The data structure 300 for the call forwarding profile 310

comprises information resident in a database used by the call forwarding application program and includes call data 320 comprising destination data 350 representing at least one call forwarding destination, duration data 330 representing a duration of the call forwarding profile and initiation data 340 corresponding to a trigger for activating the call profile. Preferably, call data 320 further comprises destination time data 360 representing the time period during which calls are forwarded to a particular call forwarding destination. The trigger for activating a particular call forwarding profile may be selected from the group comprising the time of day, calendar date, day of the week, a calendar hook, such as an appointment entered into an electronic calendar, and user input.

[0039] Referring to Figure 4, a mobile electronic device 402 capable of telecommunications is shown. Mobile electronic device 402, as described below, provides an interface through which call forwarding profiles of the embodiments of the present application may be inputted. Mobile electronic device 402 also comprises a memory comprising the data structures of the present application. The mobile electronic device 402 is preferably a two-way communication device having at least voice and advanced data communication capabilities, including the capability to communicate with other computer systems. Depending on the functionality provided by mobile electronic device 402, it may be referred to as a data messaging device, a two-way pager, a cellular telephone with data messaging capabilities, a wireless Internet appliance, or a data communication device (with or without telephony capabilities). Mobile electronic device 402 may communicate via a network 400, in this embodiment, any one of a plurality of fixed transceiver stations within its geographic coverage area.

[0040] Mobile electronic device 402 will normally incorporate a communication subsystem 411, which includes a receiver, a transmitter, and associated components, such as one or more (preferably embedded or internal) antenna elements and, local oscillators (LOs), and a processing module such as a digital signal processor (DSP) (all not shown). Communication subsystem 411. As will be apparent to those skilled in the field of communications, particular design of communication subsystem 411 depends on the communication network in which mobile electronic device 402 is intended to operate. In this embodiment of the application communication subsystem 411 includes a receiver

configured to receive data from a positioning system 470 to accurately determine the global position of mobile electronic device 402.

[0041] Network access is associated with a subscriber or user of mobile electronic device 402 and therefore mobile electronic device 402 requires a Subscriber Identity Module or "SIM" card 462 to be inserted in a SIM IF 464 in order to operate in the network. Mobile electronic device 402 is a battery-powered device so it also includes a battery IF 454 for receiving one or more rechargeable batteries 456. Such a battery 456 provides electrical power to most if not all electrical circuitry in mobile electronic device 402, and battery IF 454 provides for a mechanical and electrical connection for it. The battery IF 454 is coupled to a regulator (not shown) which provides power $V+$ to all of the circuitry.

[0042] Mobile electronic device 402 includes a controller such as a microprocessor 438 which controls overall operation of mobile electronic device 402. Communication functions, including at least data and voice communications, are performed through communication subsystem 411. Microprocessor 438 also interacts with additional device subsystems such as a display 422, a flash memory 424, a random access memory (RAM) 426, auxiliary input/output (I/O) subsystems 428, a serial port 430, a keyboard 432, a speaker 434, a microphone 436, a short-range communications subsystem 440, and any other device subsystems generally designated at 442. Microprocessor 438 is also capable of adjusting the intensity of backlight according to a state of at least one light condition affecting ambient light at the global position of the device. Some of the subsystems shown in Figure 4 perform communication-related functions, whereas other subsystems may provide "resident" or on-device functions. Notably, some subsystems, such as keyboard 432 and display 422, for example, may be used for both communication-related functions, such as entering a text message for transmission over a communication network, and device-resident functions such as a calculator or task list. Keyboard 432 and display 422 form one possible interface throughout which a user may input a call forwarding profile according to the embodiments of the present application. Operating system software used by microprocessor 438 is preferably stored in a persistent store such as flash memory 424, which may alternatively be a read-only memory (ROM) or similar storage element (not shown). Those skilled in the art

will appreciate that the operating system, specific device applications, or parts thereof, may be temporarily loaded into a volatile store such as RAM 426.

[0043] Microprocessor 438, in addition to its operating system functions, preferably enables execution of software applications on mobile electronic device 402. A predetermined set of applications which control basic device operations, including at least data and voice communication applications, will normally be installed on mobile electronic device 402 during its manufacture. A preferred application that may be loaded onto mobile electronic device 402 may be a personal information manager (PIM) application having the ability to organize and manage data items relating to the user such as, but not limited to, instant messaging (IM), e-mail, calendar events, voice mails, appointments, and task items. Naturally, one or more memory stores are available on mobile electronic device 402 and SIM 462 to facilitate storage of PIM data items and other information.

[0044] The PIM application preferably has the ability to send and receive data items via the wireless network. In a preferred embodiment, PIM data items are seamlessly integrated, synchronized, and updated via the wireless network, with the mobile electronic device user's corresponding data items stored and/or associated with a host computer system thereby creating a mirrored host computer on mobile electronic device 402 with respect to such items. This is especially advantageous where the host computer system is the mobile electronic device user's office computer system. Additional applications may also be loaded onto mobile electronic device 402 through network 400, an auxiliary I/O subsystem 428, serial port 430, short-range communications subsystem 440, or any other suitable subsystem 442, and installed by a user in RAM 426 or preferably a non-volatile store (not shown) for execution by microprocessor 438. Such flexibility in application installation increases the functionality of mobile electronic device 402 and may provide enhanced on-device functions, communication-related functions, or both. For example, secure communication applications may enable electronic commerce functions and other such financial transactions to be performed using mobile electronic device 402.

[0045] In a data communication mode, a received signal such as a text message, an e-mail message, or web page download will be processed by communication subsystem 411

and input to microprocessor 438. Microprocessor 438 will preferably further process the signal for output to display 422, to auxiliary I/O device 428 or both. A user of mobile electronic device 402 may also compose data items, such as e-mail messages, for example, using keyboard 432 in conjunction with display 422 and possibly auxiliary I/O device 428. Keyboard 432 is preferably a telephone type keypad, full alphanumeric keyboard or full or condensed QWERTY keypad. These composed items may be transmitted over a communication network through communication subsystem 411.

[0046] For voice communications, the overall operation of mobile electronic device 402 is substantially similar, except that the received signals would be output to speaker 434 and signals for transmission would be generated by microphone 436. Alternative voice or audio I/O subsystems, such as a voice message recording subsystem, may also be implemented on mobile electronic device 402. Although voice or audio signal output is preferably accomplished primarily through speaker 434, display 422 may also be used to provide an indication of the identity of a calling party, duration of a voice call, or other voice call related information, as some examples.

[0047] Serial port 430 in Figure 4 is normally implemented in a personal digital assistant (PDA)-type communication device for which synchronization with a user's desktop computer is a desirable, albeit optional, component. Serial port 430 enables a user to set preferences through an external device or software application and extends the capabilities of mobile electronic device 402 by providing for information or software downloads to mobile electronic device 402 other than through a wireless communication network. The alternate download path may, for example, be used to load an encryption key onto mobile electronic device 402 through a direct and thus reliable and trusted connection to thereby provide secure device communication.

[0048] Short-range communications subsystem 440 of Figure 4 is an additional optional component which provides for communication between mobile electronic device 402 and different systems or devices, which need not necessarily be similar devices. For example, subsystem 4240 may include an infrared device and associated circuits and components, or a Bluetooth™ communication module to provide for communication with

similarly enabled systems and devices. Bluetooth™ is a registered trademark of Bluetooth SIG, Inc.

[0049] In accordance with an embodiment of the application, mobile electronic device 402 is configured for sending and receiving data items and includes a PIM for organizing and managing data items relating to the user such as, but not limited to, instant messaging (IM), e-mail, calendar events, calendar appointments, and task items, etc. By way of example, mobile electronic device 402 is configured for voice (which may include push to talk over cellular (POC)) and data services, voice mail service, e-mail service, SMS and chat services to which the user subscribes. To provide a user-friendly environment to control the operation of mobile electronic device 402, PIM together with the operation system and various software applications resident on the station 402 provides a GUI having a main screen from which to access various services via applications stored on said device or available to it, including but not limited to applications relating to inputting a call forwarding profile.

[0050] Some or all the instructions representing the methods in respect of embodiments, in accordance with one aspect of the application, may be stored in any of the memory stores described above and executed by microprocessor 438. Furthermore, any of the memory stores may comprise the data structures described above with respect to embodiments in accordance with another aspect of the application.

[0051] The sequences of instructions which when executed cause the methods described herein to be performed by system can be contained in a data carrier product for transmission such as embodied in a carrier wave according to one embodiment of the application.

[0052] The sequences of instructions which when executed cause the methods described herein to be performed by system can be contained in a computer software product according to one embodiment of the application. This computer software product can be loaded into and run by system.

[0053] The sequences of instructions which when executed cause the methods described herein to be performed by system can be contained in an integrated circuit product including a coprocessor or memory according to one embodiment of the application. This integrated circuit product can be installed in system.

[0054] The embodiments of the application described above are intended to be examples only. Those of skill in the art may effect alterations, modifications and variations to the particular embodiments without departing from the scope of the application. The subject matter described herein in the recited claims intends to cover and embrace all suitable changes in technology.

We claim:

1. A method of forwarding calls placed to a primary phone number comprising:

receiving at least one call forwarding profile, the at least one call forwarding profile having a predefined duration, at least one call forwarding phone number, and at least one predetermined time period of activation within the predefined duration for forwarding calls placed to the primary phone number to the at least one call forwarding phone number;

receiving an instruction to activate the at least one call forwarding profile; and

forwarding calls placed to the primary phone number according to the activated call forwarding profile,

the at least one call forwarding profile defining at least one predetermined time period within the predefined duration in which calls placed to the phone number are not forwarded.
2. The method of claim 1, wherein the at least one call forwarding profile defines two or more predetermined time periods of activation within the predetermined duration for forwarding calls placed to the primary phone number.
3. The method of claim 1, wherein the at least one call forwarding profile is automatically de-activated after the duration has elapsed.
4. The method of claim 1, wherein the instruction to activate the at least one call forwarding profile is generated in response to a trigger.
5. The method of claim 4, wherein the trigger is selected from the group comprising of time of day, calendar date, day of the week, calendar hook and user input.
6. A data processing system having a processor and a memory for storing data for access by an application program being executed on the data processing system, the data processing system being configured by the application program to process a data structure for a call forwarding profile stored in the memory, the data structure comprising:

call data comprising destination data representing at least one call forwarding destination;

duration data representing a duration of the at least one call forwarding profile;

time data representing at least one predetermined time period of activation within the duration for forwarding calls to the at least one call forwarding destination; and

initiation data corresponding to a trigger for activating the at least one call forwarding profile,

the at least one call forwarding profile defining at least one predetermined time period within the duration in which calls placed to the phone number are not forwarded.

7. The data processing system of claim 6, wherein the time data further represents two or more predetermined time periods of activation within the predefined duration for forwarding calls.

8. The data processing system of claim 6, wherein the trigger is selected from the group comprising of time of day, specific date, day of the week, calendar hook and user input.

9. A computer readable storage device storing statements and instructions for use in the execution in a computer of the method of claim 1.

10. A wireless device comprising the readable storage device of claim 9.

11. A system for forwarding calls placed to a primary phone number comprising:

a processor operatively connected to a memory, the memory comprising data and instructions to configure the processor to:

receive at least one call forwarding profile, the at least one call forwarding profile having a predefined duration, at least one call forwarding phone number, and at least one predetermined time period of activation within the predefined duration for forwarding calls placed to the primary phone number to the at least one call forwarding phone number;

receive an instruction to activate the at least one call forwarding profile; and

forward calls placed to the primary phone number according to the activated call forwarding profile.

12. An integrated circuit product containing sequences of instructions which when executed causes the performance of the method according claim 1.

13. The method of claim 2, wherein during at least one of the two or more predetermined time periods of activation calls placed to the primary phone number are forwarded to the at least one call forwarding phone number, and during at least one of the two or more predetermined time periods of activation calls placed to the primary phone number are forwarded to a second forwarding phone number.

14. The data processing system of claim 7, wherein the time data further represents at least one of the two or more predetermined time periods of activation and calls placed to the primary phone number are forwarded to the at least one call forwarding destination, and during at least one of the two or more predetermined time periods of activation calls placed to the primary phone number are forwarded to a second forwarding destination.

15. A method of forwarding calls placed to a primary phone number comprising:

receiving at least one call forwarding profile, the at least one call forwarding profile defining a predefined duration, at least one call forwarding phone number, at least one predetermined time period of forwarding within the predefined duration for forwarding calls placed to the primary phone number to the at least one call forwarding phone number, and at least one predetermined time period of non-forwarding within the predefined duration in which calls placed to the primary phone number are not forwarded;

receiving an instruction to activate the at least one call forwarding profile; and

forwarding calls placed to the primary phone number according to the activated call forwarding profile.

16. The method of claim 15, wherein the at least one call forwarding profile defines two or more predetermined time periods of forwarding within the predetermined duration for forwarding calls placed to the primary phone number.

17. The method of claim 16, wherein during at least a first one of the two or more predetermined time periods of forwarding, calls placed to the primary phone number are forwarded to the at least one call forwarding phone number, and during at least a second one of the two or more predetermined time periods of forwarding, calls placed to the primary phone number are forwarded to a second forwarding phone number.

18. The method of any one of claims 15 to 17, wherein the at least one call forwarding profile is automatically de-activated after the duration has elapsed.

19. The method of any one of claims 15 to 18, wherein the instruction to activate the at least one call forwarding profile is generated in response to a trigger.

20. The method of claim 19, wherein the trigger is selected from the group comprising of time of day, calendar date, day of the week, calendar hook and user input.

21. A data processing system having a processor and a memory for storing data for access by an application program being executed on the data processing system, the data processing system being configured by the application program to process a data structure for a call forwarding profile stored in the memory, the data structure comprising:

call data comprising destination data representing at least one call forwarding destination;

duration data representing a duration of the at least one call forwarding profile;

first time data representing at least one predetermined time period of forwarding within the duration for forwarding calls to the at least one call forwarding destination;

second time data representing at least one predetermined period of non-forwarding within the duration in which calls are not forwarded; and

initiation data corresponding to a trigger for activating the at least one call forwarding profile.

22. The data processing system of claim 21, wherein the first time data further represents two or more predetermined time periods of forwarding within the predefined duration for forwarding calls.

23. The data processing system of claim 22, wherein the first time data further represents at least a first one of the two or more predetermined time periods of forwarding, during which calls placed to the primary phone number are forwarded to the at least one call forwarding destination, and at least a second one of the two or more predetermined time periods of forwarding, during which calls placed to the primary phone number are forwarded to a second forwarding destination.

24. The data processing system of any one of claims 21 to 23, wherein the trigger is selected from the group comprising of time of day, specific date, day of the week, calendar hook and user input.

25. A computer readable storage device storing statements and instructions for use in the execution of a computer according to the method of any one of claims 15 to 20.

26. A wireless device comprising the readable storage device of claim 25.

27. A system for forwarding calls placed to a primary phone number comprising:

a processor operatively connected to a memory, the memory comprising data and instructions to configure the processor to:

receive at least one call forwarding profile, the at least one call forwarding profile defining a predefined duration, at least one call forwarding phone number, and at least one predetermined time period of forwarding within the predefined duration for forwarding calls placed to the primary phone number to the at least one call forwarding phone number;

receive an instruction to activate the at least one call forwarding profile; and

forward calls placed to the primary phone number according to the activated call forwarding profile.

28. The system of claim 27, wherein the at least one call forwarding profile further defines at least one predetermined time period of non-forwarding within the predefined duration in which calls placed to the primary phone number are not forwarded.

29. An integrated circuit product containing sequences of instructions which when executed causes the performance of the method according to any one of claims 15 to 20.

30. A method of forwarding calls placed to a primary phone number comprising:

receiving at least one call forwarding profile, the at least one call forwarding profile defining a predefined de-activation criterion, at least one call forwarding phone number, at least one predetermined time period of forwarding during which calls placed to the primary phone number are forwarded to the at least one call forwarding phone number, and at least one predetermined time period of non-forwarding during which calls placed to the primary phone number are not forwarded; and

in response to a received instruction to activate the at least one call forwarding profile, forwarding calls placed to the primary phone number according to the activated call forwarding profile.

31. The method of claim 30, wherein the at least one call forwarding profile defines two or more predetermined time periods of forwarding during which calls placed to the primary phone number are forwarded.

32. The method of claim 31, wherein during at least a first one of the two or more predetermined time periods of forwarding, calls placed to the primary phone number are forwarded to the at least one call forwarding phone number, and during at least a second one of the two or more predetermined time periods of forwarding, calls placed to the primary phone number are forwarded to a second forwarding phone number.33. The method of any one of claims 30 to 32, wherein the at least one call forwarding profile is automatically de-activated when the de-activation criterion is met.

34. The method of any one of claims 30 to 33, wherein the de-activation criterion is at least one of: a time of day, a day of week, a specific date, a time duration since activation, and receipt of an instruction to de-activate.

35. The method of any one of claims 30 to 34, wherein the instruction to activate the at least one call forwarding profile is generated in response to an activation trigger.

36. The method of claim 35, wherein the trigger is selected from the group comprising of time of day, calendar date, day of the week, calendar hook and user input.

37. The method of any one of claims 30 to 36, wherein the at least one call forwarding profile is defined to repeat until the de-activation criterion is met.

38. A data processing system comprising a processor and a memory for storing data for access by an application program being executed on the data processing system, the data processing system being configured by the application program to process a data structure for at least one call forwarding profile stored in the memory, the data structure comprising:

call data comprising destination data representing at least one call forwarding destination;

de-activation data representing a de-activation criterion of the at least one call forwarding profile;

first time data representing at least one predetermined time period of forwarding during which calls are forwarded to the at least one call forwarding destination;

second time data representing at least one predetermined time period of non-forwarding during which call are not forwarded; and

initiation data corresponding to a trigger for activating the at least one call forwarding profile.

39. The data processing system of claim 38, wherein the first time data further represents two or more predetermined time periods of forwarding during which calls are forwarded.

40. The data processing system of claim 39, wherein the first time data further represents at least one of the two or more predetermined time periods of forwarding, during which calls placed to the primary phone number are forwarded to the at least one call forwarding destination, and at least a second one of the two or more predetermined time periods of forwarding, during which calls placed to the primary phone number are forwarded to a second forwarding destination.

41. The data processing system of any one of claims 38 to 40, wherein the trigger is selected from the group comprising of time of day, specific date, day of the week, calendar hook and user input.

42. The data processing system of any one of claims 38 to 41, wherein the at least one call forwarding profile is automatically de-activated when the de-activation criterion is met.

43. The data processing system of any one of claims 38 to 42, wherein the de-activation criterion is at least one of: a time of day, a day of week, a specific date, a time duration since activation, and receipt of an instruction to de-activate.

44. The data processing system of any one of claims 38 to 43, wherein the at least one call forwarding profile is defined to repeat until the de-activation criterion is met.

45. A computer readable storage device storing statements and instructions for use in the execution of a computer according to the method of any one of claims 30 to 37.

46. A wireless device comprising the readable storage device of claim 45.

47. A system for forwarding calls placed to a primary phone number comprising:

a processor operatively connected to a memory, the memory comprising data and instructions to configure the processor to carry out the method of any one of claims 30 to 37.

48. An integrated circuit product containing sequences of instructions which when executed causes the performance of the method according to any one of claims 30 to 37.

1/4

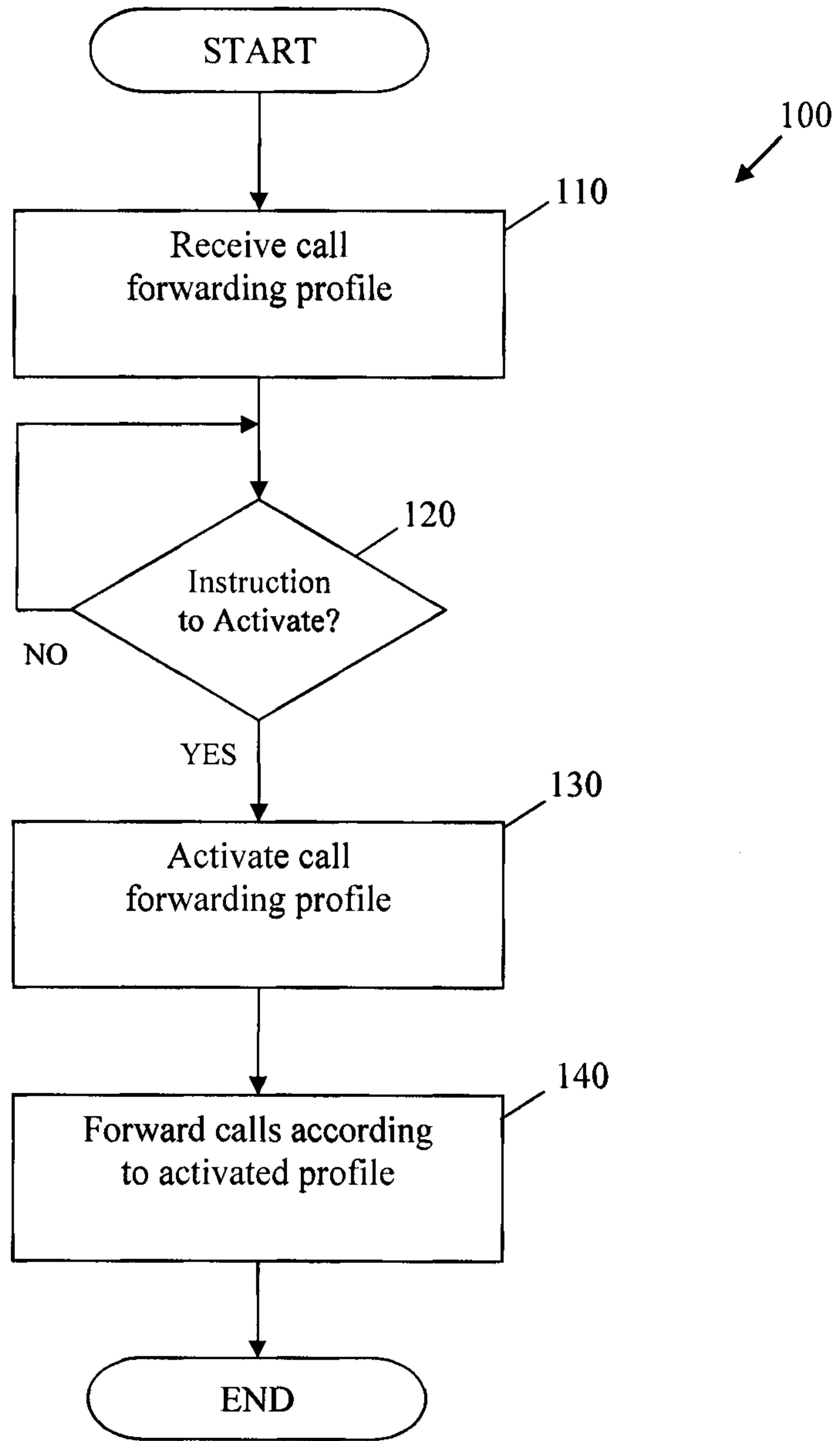

FIGURE 1

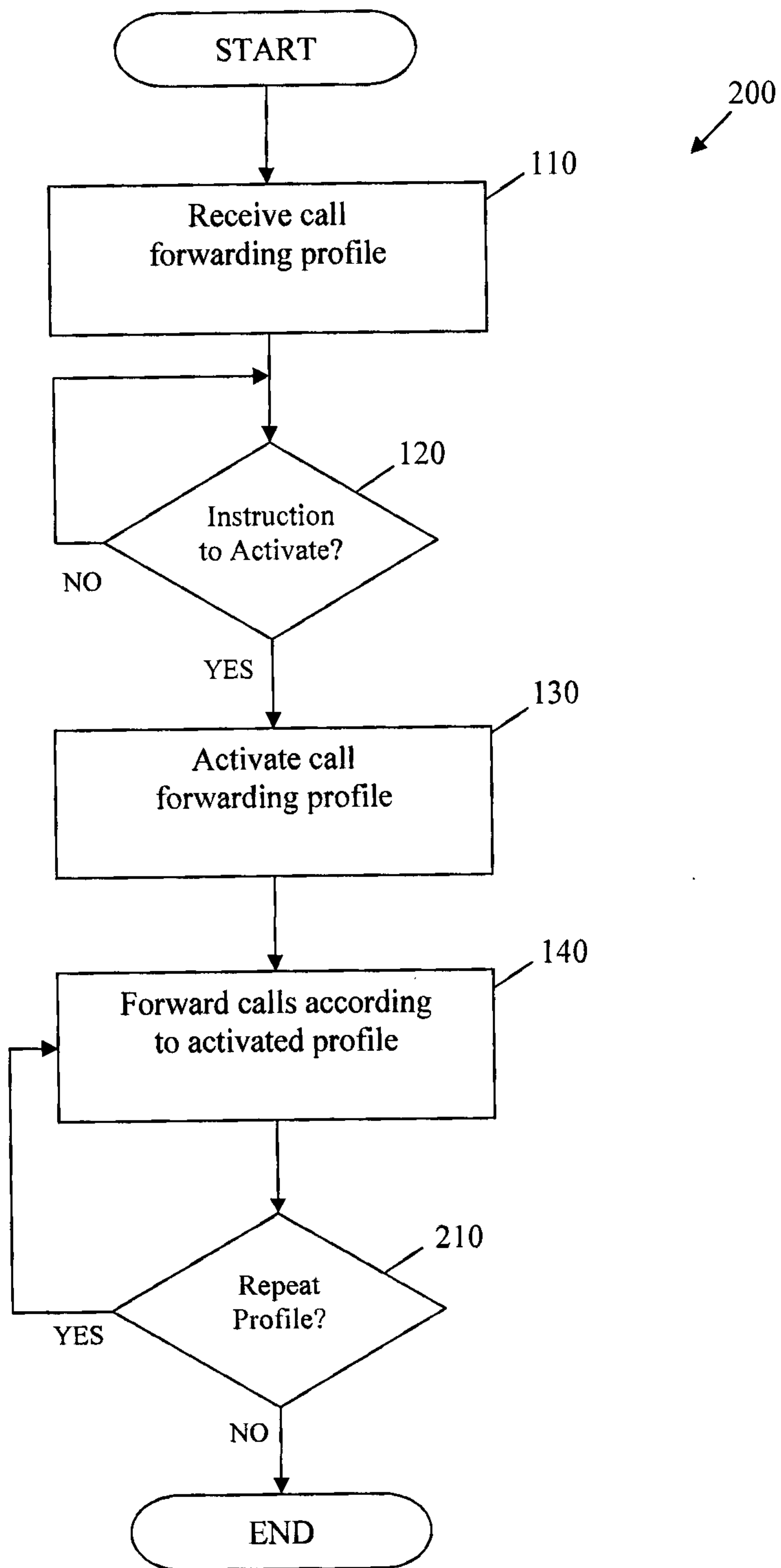

FIGURE 2

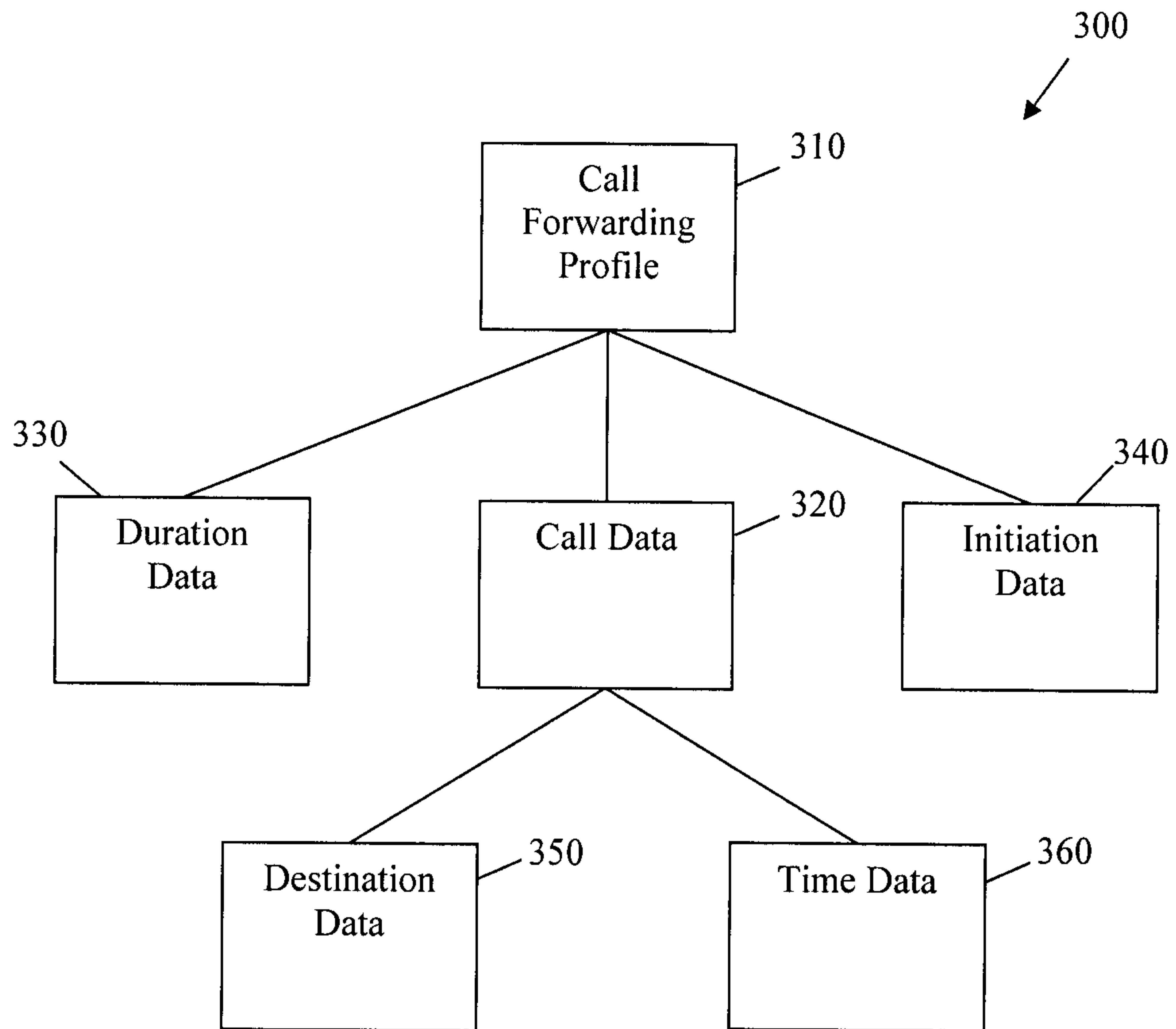

FIGURE 3

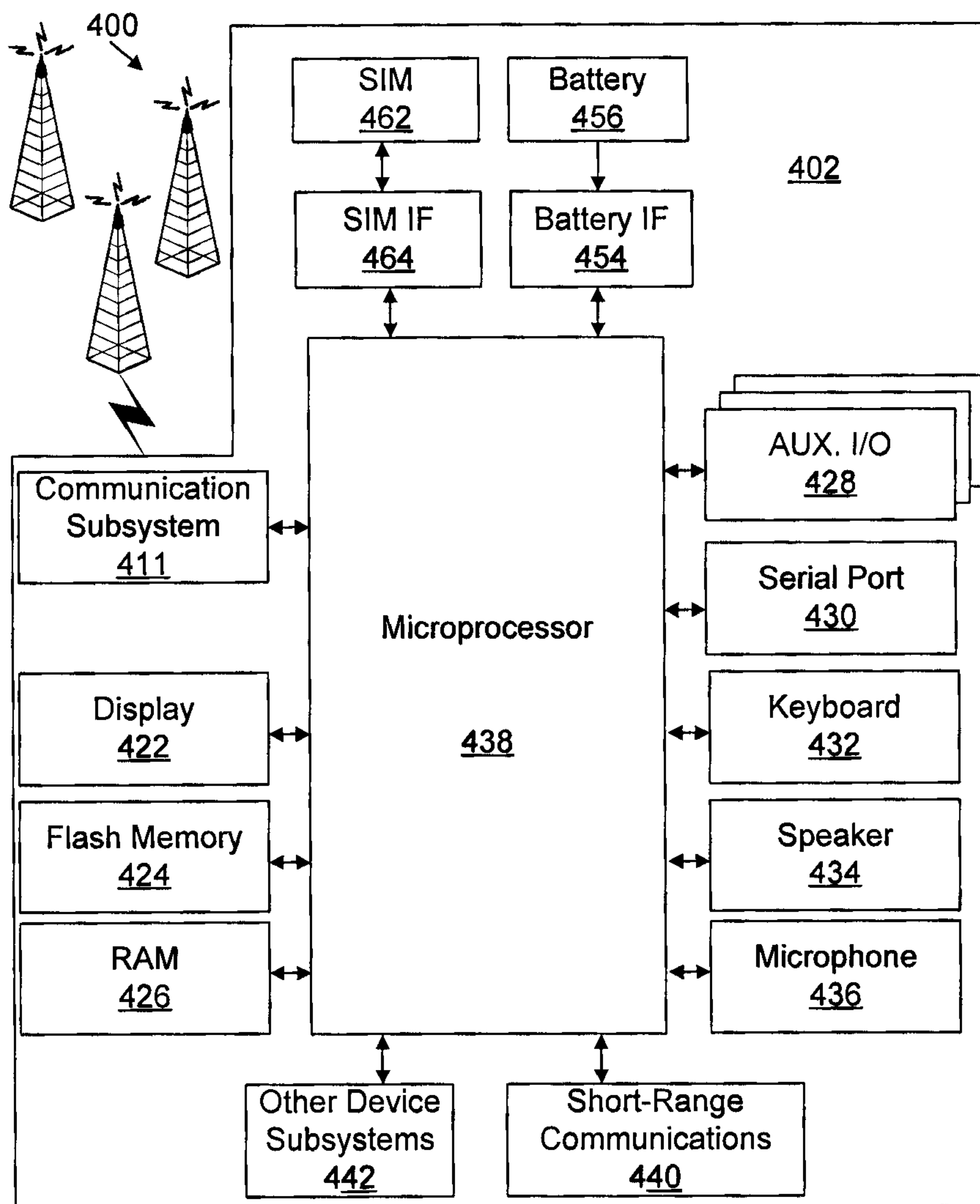

FIGURE 4

