

W. JACKSON.
 PRINTING MACHINE.
 APPLICATION FILED JULY 28, 1910.

994,590.

Patented June 6, 1911.

Fig. 1.

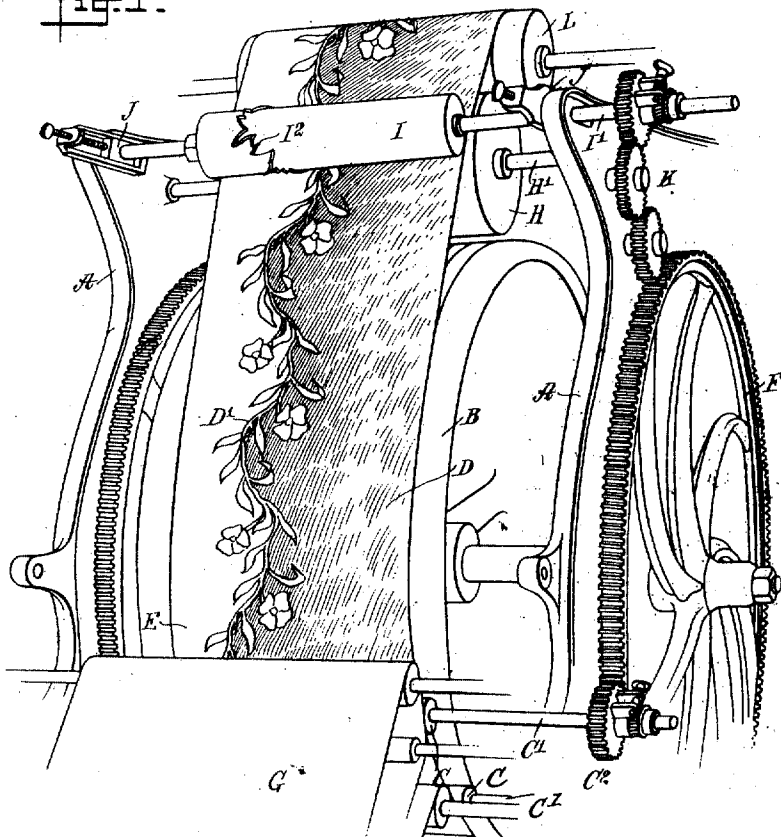
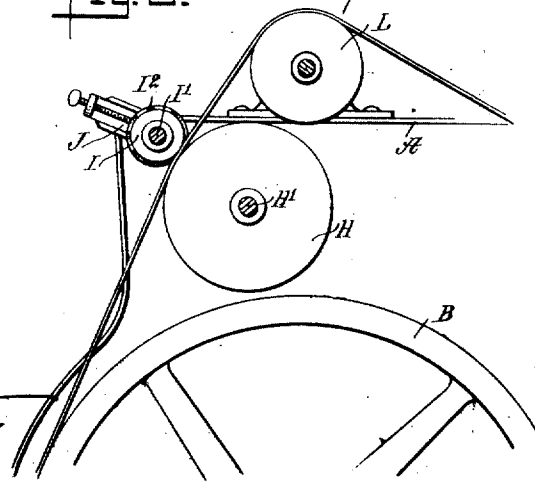

Fig. 2.



WITNESSES:

Edmund [unclear]
Geo. [unclear]

INVENTOR
William Jackson
 BY *Munn Co.*
 ATTORNEYS

UNITED STATES PATENT OFFICE.

WILLIAM JACKSON, OF NEW YORK, N. Y., ASSIGNOR TO THE ROBERT GRAVES COMPANY, OF NEW YORK, N. Y.

PRINTING-MACHINE.

994,590.

Specification of Letters Patent.

Patented June 6, 1911.

Application filed July 26, 1910. Serial No. 573,884.

To all whom it may concern:

Be it known that I, WILLIAM JACKSON, a citizen of the United States, and a resident of the city of New York, borough of Brooklyn, in the county of Kings and State of New York, have invented new and useful Improvements in Printing-Machines, of which the following is a full, clear, and exact description.

10 The invention relates to wall paper printing machines, and its object is to provide certain new and useful improvements in printing machines for printing wall paper borders, whereby the paper after it receives the imprint by the printing rolls is accurately cut lengthwise along the contour of the imprint. For the purpose mentioned, use is made of a cutting roll rotating in unison with the printing rolls and having a peripheral cutting edge corresponding to the contour of the imprint produced on the paper by the printing rolls.

15 A practical embodiment of the invention is represented in the accompanying drawings forming a part of this specification, in which similar characters of reference indicate corresponding parts in both views.

20 Figure 1 is a perspective view of part of the wall paper printing machine provided with the device for cutting the paper lengthwise along the contour of the imprint; and Fig. 2 is a sectional side elevation of the same.

25 The printing machine is mounted on a suitably constructed frame A, in which is mounted to rotate the impression cylinder B and the printing rolls C for producing the imprint D on the paper E passing around the impression cylinder B in the usual manner.

30 The shaft C' of each of the printing rolls C is provided at one end with a pinion C², in mesh with a gear wheel F rotating in unison with the impression cylinder B, so that the printing rolls C rotate in unison with each other, and each printing roll C is supplied with ink by a suitable inking device G, as

indicated in Fig. 1. As is well known the printing rolls C produce the imprint D in the desired number of colors on the paper E.

35 The printing machine so far described is of well known type, and it is not deemed necessary to further describe the detail mechanism thereof.

40 On the delivery side of the printing machine are arranged rolls H and I, of which the roll I is a cutting roll and the roll H an impression roll, and between the said rolls passes the paper E after it has received the imprint D of the printing rolls C. The shaft I' of the roll I is journaled in bearings J held adjustably on the frame A, so as to permit of moving the roll I closer to or farther from the roll H, which latter is journaled in the frame A. The shaft I' of the roll I is connected by a gearing K with the gear wheel F, so as to rotate the roll I in unison with the printing rolls C. On the peripheral face of the roll I is arranged a continuous cutting edge I², conforming in shape to the contour D' formed on the imprint D by the printing rolls C, and as the cutting roll I rotates in unison with the printing rolls C, it is evident that when the machine is running the cutting edge I² cuts the paper E lengthwise along the contour D' of the imprint D. The paper E, after it is cut lengthwise as described, passes over a roll L, and then the portion having the imprint D is passed to a drying rack, while the blank portion is carried off to one side of the machine as waste.

45 Having thus described my invention, I claim as new and desire to secure by Letters Patent:

50 In a printing machine for printing wall paper borders, the combination with the impression cylinder, a gear wheel rotating in unison with said cylinder, and printing rolls having pinions on the shafts of the printing rolls meshing with the said gear wheel, of a pair of rolls on the delivery side of the machine and between which passes

the printed paper, one of the rolls being an impression roll and the other a cutting roll mounted in adjustable bearings, said cutting roll having on its periphery a continuous cutting edge conforming in shape to the contour of the imprint on the paper, and gearing connecting the shaft of the cutting roll with the said gear wheel.

In testimony whereof I have signed my name to this specification in the presence of two subscribing witnesses.

WILLIAM JACKSON.

Witnesses:

W. W. SWEETLAND,
GEO. O. HILL.