

[54] PHOTOGRAPH ALBUM PAGE
 [75] Inventor: John M. Reynard, Framingham, Mass.
 [73] Assignee: Polaroid Corporation, Cambridge, Mass.
 [22] Filed: Dec. 29, 1972
 [21] Appl. No.: 319,227

2,191,425 2/1940 Christiansen et al. 40/104.18
 2,259,211 10/1941 Morgan 40/158 B
 2,262,058 11/1941 Sinclair 40/16
 3,195,258 7/1965 Gwin 40/158 R
 3,277,598 10/1966 Lightburn 40/63 A X
 3,727,334 4/1973 Sakamoto 40/104.18
 3,763,582 10/1973 Stevens et al. 40/104.18

FOREIGN PATENTS OR APPLICATIONS

1,043,280 11/1958 Germany 40/104.19

[52] U.S. Cl. 40/104.18, 40/158 B
 [51] Int. Cl. B42f 9/00, G09f 1/12
 [58] Field of Search 40/102, 104.02, 104.06, 40/104.18, 104.19, 158 R, 158 B, 159, 16, 64 R, 65 R

Primary Examiner—J. H. Wolff
 Attorney, Agent, or Firm—Alfred E. Corrigan

[57] ABSTRACT

A photograph album page providing rails containing passages to slidably receive photographic prints, a constriction in the passages positioning and releasably retaining the photographic prints mounted on the page.

4 Claims, 5 Drawing Figures

[56] References Cited
 UNITED STATES PATENTS

1,244,622 10/1917 McCauley 40/102
 1,394,231 10/1921 Soans 40/104.06
 1,513,027 10/1924 Belli 40/16 X

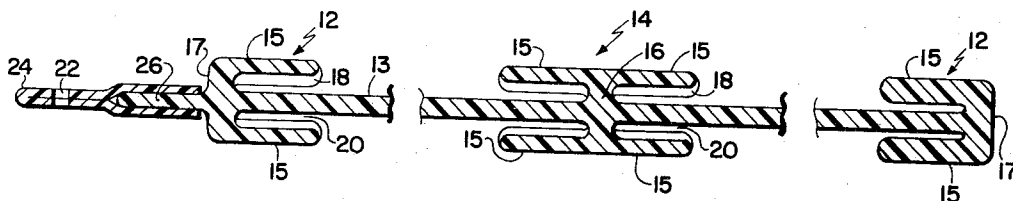

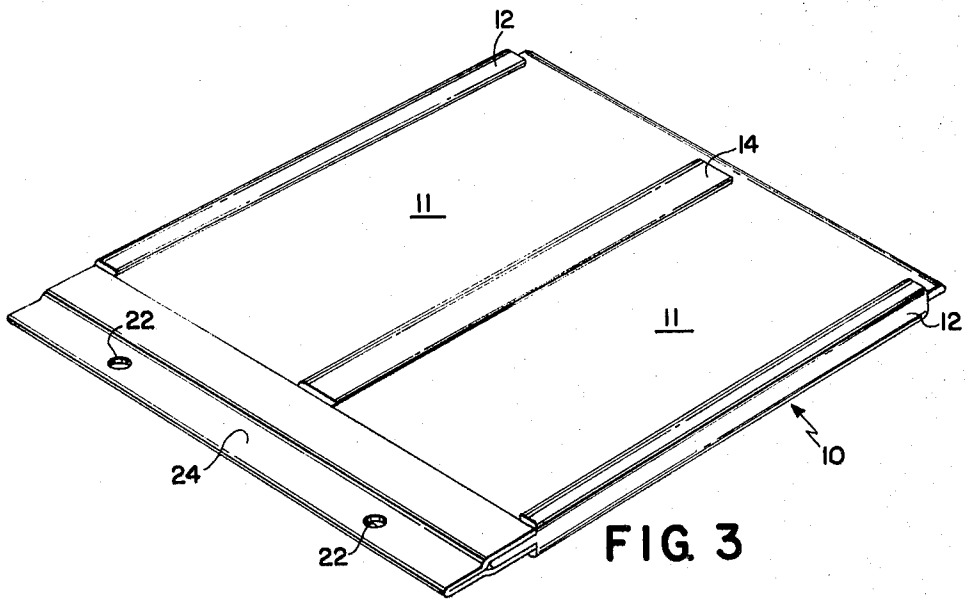
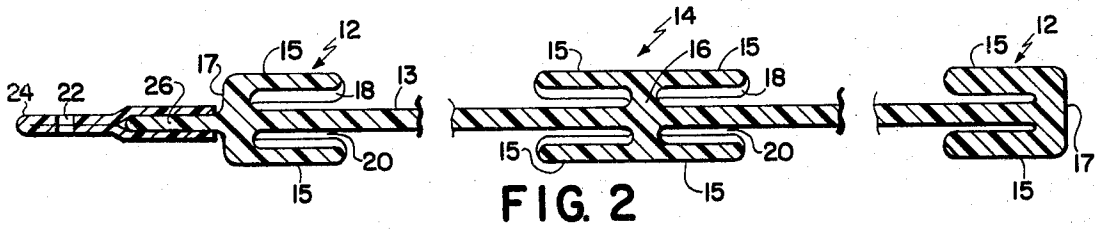
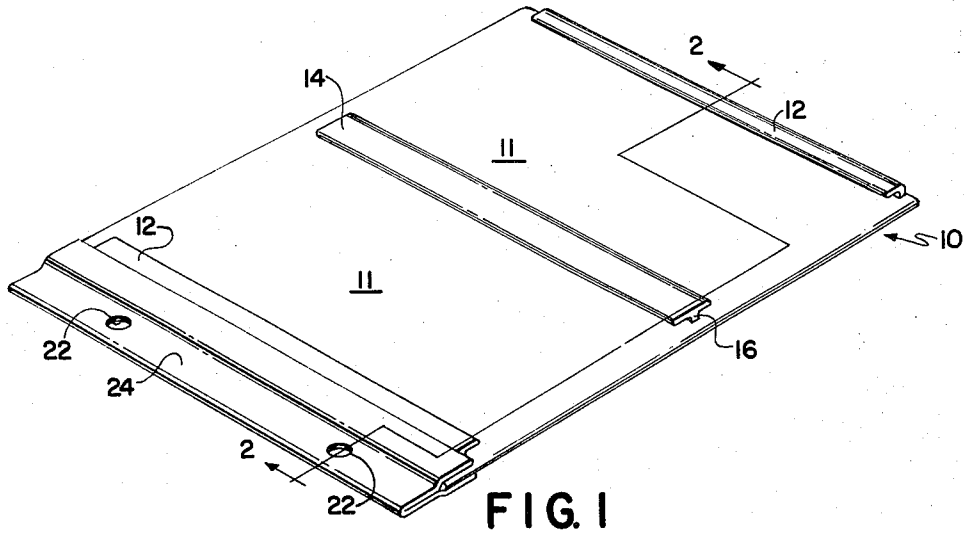

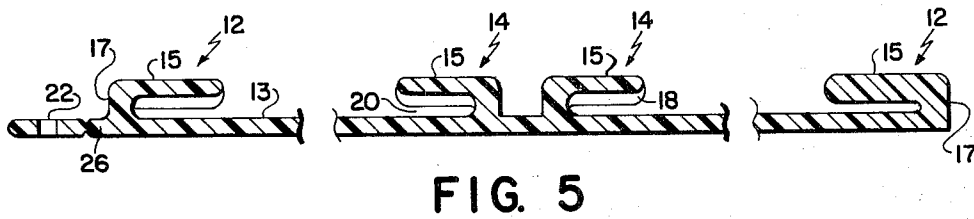
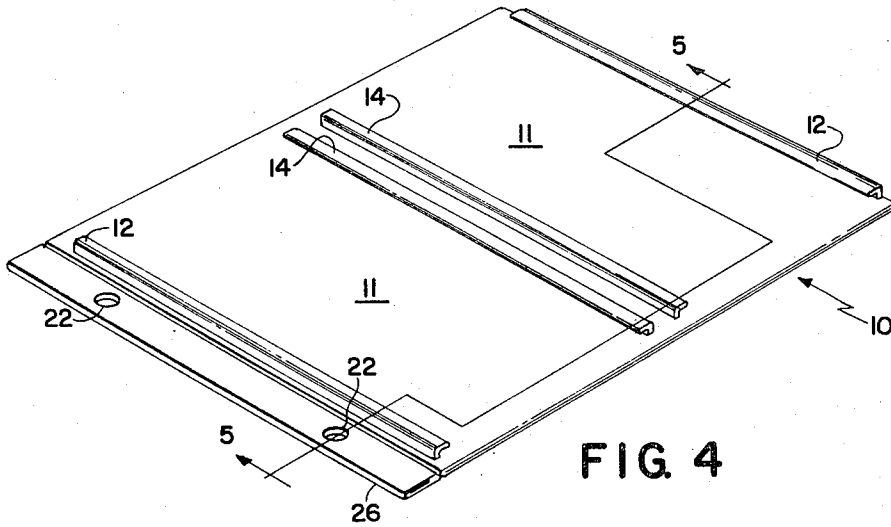

PHOTOGRAPH ALBUM PAGE

BACKGROUND OF THE INVENTION

1. Field of the Invention

This invention relates to photograph albums, and more specifically to a novel album page including means for releasably retaining photographic prints on the album page.

2. Description of the Prior Art

The construction and manufacture of albums and album pages is not new in the photographic field. The majority of commercially available albums, however, do not retain a photographic print in a most aesthetically pleasing manner. These album pages commonly use adhesive backed paper corners at each of the photographic print's four corners to mount the print to the album page. Although the paper corners permit viewing of the photographic prints, the adhering ability of the corners deteriorates with age and more rapidly with climatic changes resulting in damage to or loss of prized photographic prints. The paper corners frequently do not present a clean or neat looking holding arrangement and frequently the photographic prints are not orderly positioned on the page.

Another commonly used album page is a variety formed of a sheet with plastic pockets provided thereon, each pocket dimensioned to contain several photographic prints. Generally, these pockets do not provide any means for securing the individual photographic prints within the pocket, frequently resulting in a disorientated looking collage. Furthermore, removal or insertion of prints is frequently difficult, with one print tending to overlap another.

Other album pages have transparent plastic pockets each holding a single print; these pockets protect the photographic prints from tearing and scratching but the print must be viewed through the plastic pocket, thereby detracting from the photographic image quality.

Thus, it will be seen that a variety of album pages, mounts, and holders have been developed for holding photographs and transparencies, including holders constructed of relatively rigid materials. As illustrations of such holders mention may be made of U.S. Pat. Nos. 3,195,258; 3,460,282; 2,925,677 and 2,262,058.

BRIEF SUMMARY OF THE INVENTION

This application is specifically concerned with an improved album page of the general type disclosed and claimed in the copending application for United States Patent entitled "Photograph Album Page" by William M. Field, (application Ser. No. 319,228), filed concurrently herewith.

Accordingly, it is a principal object of the present invention to provide an album page, to be incorporated within a photographic album, in which photographic prints may be quickly and easily slidably inserted into passages provided within rails on the album page, the passages including a constricted portion adapted to receive and releasably but firmly retain the photograph. The passages allow for repeated removal and substitution of other photographic prints without damaging the prints or the page while avoiding the problem of prints sliding out of the passages.

Yet another object of the invention is to provide an album page having the passages included wherein pre-

determined alignment of the prints on the page is provided by the constriction provided within each passage.

One feature and object of the present invention is to provide such an album page which is compact, neat and attractive in appearance, inexpensive to produce, durable and convenient in use.

Another object is to provide such an album page which may be compactly arranged in a ring or other binder, whereby photographic prints may be readily inserted or removed while the page is in the binder.

Another feature and object of the present invention is to provide such an album page which permits increased functionality, and is an integrally formed product.

Other objects of the invention will in part be obvious and will in part appear hereinafter.

The novel features that are considered to be characteristic of the invention are set forth with particularity in the appended claims.

BRIEF DESCRIPTION OF THE DRAWINGS

For a fuller understanding of the nature and objects of the invention, reference should be made to the following detailed description taken in conjunction with the accompanying drawings wherein:

FIG. 1 is a perspective view of a preferred embodiment of the present invention with album retaining means included;

FIG. 2 is a sectional view taken along the line 2—2 of FIG. 1;

FIG. 3 is a perspective view of another embodiment of the invention;

FIG. 4 is a perspective view of a modified version of the embodiment of FIG. 1; and

FIG. 5 is a sectional view taken generally along the line 5—5 of FIG. 4.

DETAILED DESCRIPTION OF THE INVENTION

Referring in more detail and by reference characters to drawings of FIGS. 1 and 2 which illustrate a preferred embodiment of the invention, an album page 10 is illustrated comprising a thin rectangular sheet 13, end rails 8 and 12, and inner rails 14. Rails 8, 12 and 14 are constructed of any suitable inexpensive, relatively stiff or semi-rigid material such as a synthetic vinyl plastic or the like, and preferably are formed integral with sheet 13, as by a suitable molding or extrusion operation. An alternative method of construction may be to attach the end rails 12 and inner rails 8 and 14 to the sheet 13 in a secondary operation by heat sealing or utilizing the binding powers of an adhesive. An album retaining portion 24 constructed of a suitably flexible material provides a hinge 28 for the turning of the album page 10 when placed between album covers, preferably of the loose leaf styled album covers. The album retaining portion 24 contains album retaining apertures 22 for receiving fastening means incorporating the album page 10 into an album cover back and is attached to sheet 13 by joining the album retaining portion 24 to an extension tab 26 integrally formed with the sheet 13 and adjoining the end rail 8.

The end rails 12, inner rails 8 and 14 and the album retaining portion 24 are parallel with each other in the preferred embodiment with a pair of photographic retaining rails being formed by combining each end rail 8 and 12 with one of the inner rails 14, thereby parti-

tioning the side of the sheet 13 into compartments 11 provided for photographic prints. The inner rails 14 include a common wall 16 thereby conserving space, upright but may contain individual upright walls 17 as shown in FIG. 4. The compartments 11 are specifically adapted for use with a film unit of the type described in Land, *Photographic Science and Engineering*, Vol. 16, pp. 247-152 (July - August, 1972). The film unit is characterized by a transparent layer which provides a protective surface for the photographic image thereby alleviating any need for an overlying transparent or translucent material to be employed for the protection of the photographic prints when mounted in the compartments 11.

The photographic prints are slidably received in passages 20 formed by positioning the upright wall 17 of each end rail and common upright wall 16 of the inner rails 14 substantially perpendicular to each side of sheet 13, with each upright wall 16 and 17 adjoining flanges 15 projecting orthogonally therefrom substantially parallel with the side of sheet 13. The flanges 15 of each pair of rails are inwardly facing and opposite, thereby providing passages 20 which capture border areas of opposing side edges of the photographic prints. Within each passage 20 there are provided constrictions 18 which reduce the height of the passage 20 to a minimum at or about the midpoint of at least one of each pair of rails. These constrictions limit the travel and thus position photographic prints slidably received in the rails. The constrictions 18 may be provided by reducing the height of the passages 20 for only a short distance from the midpoint of the rail, the distance being sufficient to grip the photographic print, as by a "crimping" type of operation. Alternatively, the constriction 18 may be provided by gradually reducing, i.e., tapering the height of the passages 20 starting at a point relatively near the open end of the passage. It is preferred that such tapering be effected by varying the thickness of the flange 15, as shown in FIGS. 2 and 5, so that the print is held relatively flat against the sheet 13. The minimum height of constrictions 18 should be such as to provide desired frictional gripping of the print, but should not be so small as to require undue force to insert the print lest the print be bent or caused to buckle. The constriction 18 releasably retains the photographic prints by frictionally engaging at least the lead-in border areas of opposing side edges of the photographic print, assuring a predetermined aligning of the edges of the print with the edge of the album page 10 and restricting the length of travel so that each of two prints is properly positioned within each pair of rails forming the compartments 11.

A modification of the present invention is illustrated in FIG. 3 with the rails 12 and 14 extending across the sheets perpendicular to the album retaining portion 24. The end rails 12 and the inner rails 14 including constrictions as previously described combine to form pairs of rails having the open side of the passages 20 of each pair inwardly facing and opposite each other to slidably receive photographic prints inserted into either open end of compartments 11.

FIG. 4 and FIG. 5 are illustrations of a second embodiment of the present invention. A pair of spaced-apart inner rails 14 have individual upright walls 17. An extension tab 26 containing album retaining apertures 22 provided therein and including a flexible hinge portion 40 is formed integral with sheet 13. This method

of construction eliminates adding an album retaining portion in a second operation in the manufacture of the album page 10. The end rails 12 and the inner rails 14 are provided on one side of sheet 13, thereby providing the user with an option in the use of the page 10 as a room decorating display or as an album page. The page 10 has the constrictions in the rails as previously described so that the page 10 may be orientated in any position, when removed from the album, without fear of having the prints slide out of the rails.

The rails preferably terminate a short distance from the page edge, as best seen in FIGS. 1 and 4, thereby facilitating the alignment and insertion of a print. If desired, however, the rails may be expended to be essentially flush with the page edge.

It should be noted that album page 10 is not limited to use with photographs of the self-developing variety. The spacing between the pairs of rails may be enlarged or reduced, and the height of the constrictions modified, to accommodate any desired size print. Album page 10 may also be modified to include a transparent protective layer overlying flanges 15 if desired.

In a specific embodiment an album page of the type shown in FIG. 1 and designed to receive Polaroid SX-70 Land prints is cut from extruded white plastic (vinyl) stock, each page being approximately 7½ inches wide by 8½ inches high. Each album page holds eight prints, four on each side in two rows each containing one upper and one lower print therein. Each top edge of the upper prints is substantially flush with the top edge of the page, and the same relationship exists between the bottom edge of the page and each bottom edge of the lower prints. Two prints in the same row butt together where they touch.

Due to the album page construction, an album full of prints will be no thicker than an empty album, thus avoiding the bulging appearance typical of many photograph albums. The flanges are so positioned on each page as to butt against the flanges on a facing page, thus assuring that the surfaces of the mounted prints will not be touched or marred by the facing album page.

From the foregoing, it is apparent that album page 10 is an inexpensive, durable, and easily constructed unit which provides for both easy insertion and removal of photographic prints without reliance upon methods previously employed in the prior art. The album page 10 also permits double sided mounting with an unencumbered full view of the mounted photographs without any portion of the photographic image being hidden. Therefore, a clean looking and aesthetically pleasing mounting holder for photographs is provided.

This invention may be practiced or embodied in still other ways without departing from the spirit and essential character thereof. As an example of such a modification, mention may be made of the possibility of flanges 15 formed with a uniform thickness and mounted on wall 17 in such a manner as to be nonparallel to sheet 13. In such an embodiment, the flanges 15 viewed from each side would slope upward from the midpoint of passage 20 to a predetermined point on either side of the midpoint. Such a variation provides an opportunity to modify the aesthetic appearance of the album page while retaining the functions of the passages 20 and the constrictions 18. The specific and preferred embodiments described herein are therefore to be considered illustrative and not restrictive, the scope of the invention being indicated by the appended

claims and all variations which come within the meaning of the claims are intended to be embraced therein.

What is claimed is:

1. An album page comprising:

a relatively thin, self-supporting rectangular sheet;
 at least two pairs of parallel rails for slideably receiving and releasably retaining photographic prints therein carried on one side of said sheet, each rail of said pairs of parallel rails including an upright wall portion rising from said side of said sheet and having a flange portion projecting therefrom adapted to retain opposite edges of the photographic print thereunder, said upright wall portion and said flange portion cooperating with said side of said sheet to provide a substantially unobstructed passage terminating in oppositely disposed open ends and having one open side running substantially from one end to an opposing end of said sheet, said open side of said passage within each rail of said pair of parallel rails inwardly facing and opposite each other whereby photographic prints

may be inserted between said oppositely facing rails from either said one end or said opposing end of said sheet; and

constricting means substantially centrally located intermediate the ends of said passage for preventing the movement of a photographic print, located within said passages, from said one end to said other end of said sheet, said constricting means protruding into said passage for frictionally engaging and releasably retaining the opposite edges of the photographic print when the photographic print is located in its final position relative to said sheet.

2. An album page as defined in claim 1 wherein said constricting means is tapered down said end of said sheet.

3. An album page as defined in claim 1 wherein said rails terminate a short distance from the edges of said sheet.

4. An album page as defined in claim 1 wherein said sheet and said rails are integral with each other.

* * * * *

25

30

35

40

45

50

55

60

65