



(51) International Patent Classification:

H01L 41/047 (2006.01) H01L 41/193 (2006.01)  
H01L 41/083 (2006.01) H01L 41/293 (2013.01)

(21) International Application Number:

PCT/DK2013/000014

(22) International Filing Date:

12 February 2013 (12.02.2013)

(25) Filing Language:

English

(26) Publication Language:

English

(30) Priority Data:

PA 2012 00117 14 February 2012 (14.02.2012) DK

(71) Applicant: DANFOSS POLYPOWER A/S [DK/DK]; Nordborgvej 81, DK-6430 Nordborg (DK).

(72) Inventors: POOLE, Alan, David; Kaermindevej 18, DK-6400 Soenderborg (DK). OUBAEK, Jakob; Brunbjergvej 26A, DK-6200 Aabenraa (DK).

(74) Agent: DANFOSS A/S; Intellectual Property, L25, Nordborgvej 81, DK-6430 Nordborg (DK).

(81) Designated States (unless otherwise indicated, for every kind of national protection available): AE, AG, AL, AM, AO, AT, AU, AZ, BA, BB, BG, BH, BN, BR, BW, BY, BZ, CA, CH, CL, CN, CO, CR, CU, CZ, DE, DK, DM, DO, DZ, EC, EE, EG, ES, FI, GB, GD, GE, GH, GM, GT, HN, HR, HU, ID, IL, IN, IS, JP, KE, KG, KM, KN, KP, KR, KZ, LA, LC, LK, LR, LS, LT, LU, LY, MA, MD, ME, MG, MK, MN, MW, MX, MY, MZ, NA, NG, NI, NO, NZ, OM, PA, PE, PG, PH, PL, PT, QA, RO, RS, RU, RW, SC, SD, SE, SG, SK, SL, SM, ST, SV, SY, TH, TJ, TM, TN, TR, TT, TZ, UA, UG, US, UZ, VC, VN, ZA, ZM, ZW.

(84) Designated States (unless otherwise indicated, for every kind of regional protection available): ARIPO (BW, GH, GM, KE, LR, LS, MW, MZ, NA, RW, SD, SL, SZ, TZ, UG, ZM, ZW), Eurasian (AM, AZ, BY, KG, KZ, RU, TJ, TM), European (AL, AT, BE, BG, CH, CY, CZ, DE, DK, EE, ES, FI, FR, GB, GR, HR, HU, IE, IS, IT, LT, LU, LV, MC, MK, MT, NL, NO, PL, PT, RO, RS, SE, SI, SK, SM,

[Continued on next page]

(54) Title: A POLYMER TRANSDUCER AND A CONNECTOR FOR A TRANSDUCER

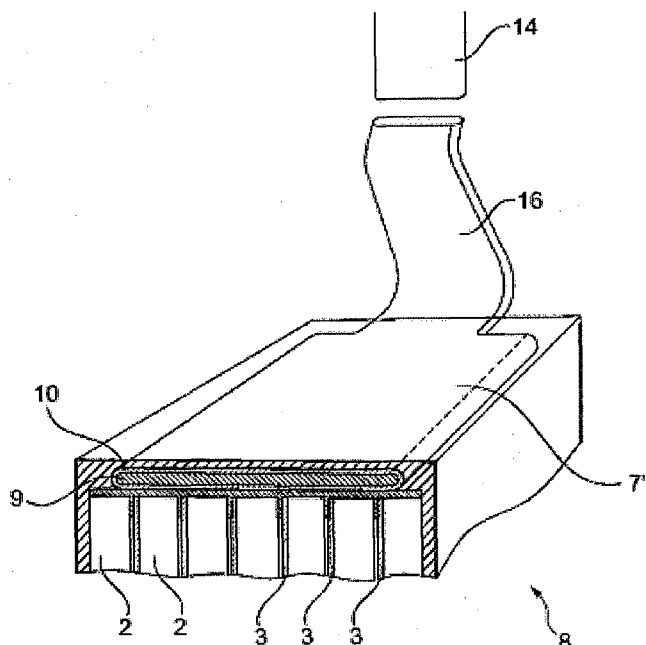

Fig. 11

(57) Abstract: The invention provides a transducer (8) comprising conductors (9, 10) and a laminate (2, 3). The laminate comprises a film of a dielectric polymer material (2) arranged between first and second electrodes (3). Each electrode (3) is in electrically conductive communication with at least one of the conductors (9, 10) to facilitate an electrical potential between the electrodes (3) and thereby enable deflection of the polymer material (2) in response to an electrical field. At least one of the conductors (9, 10) is an elastically deformable conductor comprising a compliant core (9) which is electrically conductive. The core is enclosed in a containment (10) having elastomeric properties.

WO 2013/120493 A1

TR), OAPI (BF, BJ, CF, CG, CI, CM, GA, GN, GQ, GW, ML, MR, NE, SN, TD, TG). **Published:**

— with international search report (Art. 21(3))

## A POLYMER TRANSDUCER AND A CONNECTOR FOR A TRANSDUCER

Introduction

The invention relates to a transducer comprising a laminate with a film of a dielectric polymer material arranged between first and second layers of an electrically conductive material. A  
5 conductor facilitates application of an electrical potential between the first and second layers, and due to the electrical field which may arise, the polymer material is deformed by the first and second layers when they are moved to or from each other.

Background of the invention

An electrical potential difference between two electrodes located on opposite surfaces of an  
10 elastomeric body generates an electric field leading to a force of attraction. As a result, the distance between the electrodes changes and the change leads to compression of the elastomeric material which is thereby deformed. Such structures can be used for making transducers for various purposes. When implemented as actuators they are sometimes referred to as "*artificial muscles*" due to certain similarities with a muscle. They can also be  
15 used as sensors for sensing strain, deflection, temperature variation, pressure etc., or they can be used as generators for converting mechanical energy to electrical, sometimes referred to as energy harvesting. Herein we will generally refer to these structures as transducers or polymer transducers.

US 6,376,971 discloses a compliant electrode which is positioned in contact with a polymer in  
20 such a way, that when applying a potential difference across the electrodes, the electric field arising between the electrodes contracts the electrodes against each other, thereby deflecting the polymer.

Due to the deformation of the polymer, the electrodes move, and the connector which  
25 connects the electrode to a power source must constantly follow the movement of the electrode. Typically, the connector is made sufficiently long to avoid that the electrode constitutes a constraint for the free movement of the polymer and thus reduces the efficiency of the device. Evidently, the long connectors may get entangled or be in the way. Furthermore, fatigue may be experienced over time whereby the conductance of the connector is reduced or the connector may fail completely. Finally, it is generally difficult to  
30 provide an even distribution of an electrical field in a very thin electrode. Normally, the

resistance in the electrode is high, and the resistance may increase depending on the degree of expansion of the polymer.

5 Additionally, traditional connectors are typically only attached to the electrode at an end point of the connector, i.e. at a single point of attachment, since otherwise the connector would again limit the movement of the electrode and thus the elastic deformation of the polymer. Due to this single-point attachment, it may be difficult to obtain an even distribution of the electrical field in the typically very thin electrodes.

#### Description of the invention

10 It is an object of embodiments of the invention to provide a transducer, a connector for a transducer, and a method of making a transducer to potentially improve the performance and reduce the above mentioned drawbacks of the existing connectors. Particularly, it may be seen as objects of embodiments to improve the conductivity to and from the electrodes, to improve the distribution in the electrodes and to improve the lifetime of transducers

15 According to a first aspect, the invention provides a transducer comprising conductors and a laminate, the laminate comprising a film of a dielectric polymer material arranged between first and second electrodes, and each electrode being in electrically conductive communication with at least one of the conductors to facilitate an electrical potential between the electrodes and thereby enable deflection of the polymer material in response to an electrical field, wherein at least one of the conductors is an elastically deformable conductor  
20 comprising a compliant core which is electrically conductive, the core being enclosed in a containment having elastomeric properties.

25 Since the core is made from a compliant and conductive material, the invention provides connectivity with a connector which can be elastically deformable to match the elastic deformability of the film, and the risk of fatigue is reduced or completely avoided at least with regard to the conductive core. Accordingly, the connector may follow the movement of the electrode without limiting the movement of the film.

By conductive is herein meant that it can conduct an electrical current, e.g. having an ohmic resistivity below  $10^{-4} \Omega \cdot \text{cm}$ , such as a resistivity in the range of that of aluminium, copper, silver, or alloys containing such metals.

30 The dielectric material of the film may be a polymer, e.g. an elastomer, such as a silicone elastomer, such as a weak adhesive silicone. A suitable elastomer is Elastosil RT 625,

manufactured by Wacker-Chemie. Alternatively, Elastosil RT 622 or Elastosil RT 601, also manufactured by Wacker-Chemie may be used. As an alternative, other kinds of polymers may be chosen.

5 In the case that a dielectric material which is not an elastomer is used, it should be noted that the dielectric material should have elastomer-like properties, e.g. in terms of elasticity. Thus, the dielectric material should be deformable to such an extent that the composite is capable of deflecting and thereby pushing and/or pulling due to deformations of the dielectric material.

10 The electrodes may have a thickness in the range of 0.01-0.1  $\mu\text{m}$ , and the film may have a thickness between 10  $\mu\text{m}$  and 200  $\mu\text{m}$ , such as between 20  $\mu\text{m}$  and 150  $\mu\text{m}$ , such as between 30  $\mu\text{m}$  and 100  $\mu\text{m}$ , such as between 40  $\mu\text{m}$  and 80  $\mu\text{m}$ .

The electrodes may have a resistivity which is less than  $10^{-4}$   $\Omega\cdot\text{cm}$ . By providing an electrode having a very low resistivity the total resistance of the electrodes will not become excessive, even if very long electrodes are used.

15 The electrodes may be made from a metal or an electrically conductive alloy, e.g. from a metal selected from a group consisting of metals, such as silver, gold, and nickel. Alternatively other suitable metals or electrically conductive alloys may be chosen. The electrodes may be applied to the dielectric film using standard commercial physical vapour deposition (PVD) techniques.

20 The dielectric material of the film may have a resistivity which is larger than  $10^{10}$   $\Omega\cdot\text{cm}$ . Preferably, the resistivity of the dielectric material is much higher than the resistivity of the electrodes, preferably at least  $10^{14}$ - $10^{18}$  times higher.

25 The containment may be made from an elastomer, or from a material having elastomeric properties, i.e. a material having characteristics similar to an elastomer with regard to electrical conductivity and elasticity.

The compliant core may comprise fluid, grease, gel, elastomer, powder, pasta, or mixtures hereof, such as a metal powder in a gel.

30 The laminate may comprise a film of a dielectric material having a first surface and second surface, at least the first surface comprising a surface pattern of raised and depressed surface portions. A first electrically conductive layer is deposited onto the surface pattern and forms an electrode thereon. To enable elongation of the composite in one well defined

direction, i.e. to provide compliance, the electrode has a corrugated shape which renders the length of the electrically conductive layer in a lengthwise direction, longer than the length of the laminate as such in the lengthwise direction. The corrugated shape of the electrode thereby facilitates that the laminate can be stretched in the lengthwise direction without  
5 having to stretch the electrode in that direction, but merely by evening out the corrugated shape of the electrode. The corrugated shape of the electrode may be a replica of the surface pattern of the film.

Since the electrode is deposited onto the surface pattern of the film and is formed by the shape thereof, a very precise shape of the corrugation of the electrode can be defined, and  
10 an improved compliance towards deformation in a specific direction can be provided by a suitable design of the surface pattern on the film. Accordingly, the laminate can facilitate increased actuation forces, or in general an increased rate of conversion between mechanical and electrical energies, increased lifetime and improved reaction time when the laminate is used in a transducer.

15 The compliance of the laminate in the compliant direction may be at least 50 times larger than its compliance in the non-compliant direction, i.e. perpendicularly to the compliant direction.

In one embodiment, the laminate may comprise a multilayer composite e.g. by arranging films each with at least one electrode in a stack and by applying an electrical potential  
20 difference between each adjacent electrodes in the stack so that the layers are biased towards each other while they are simultaneously flattened out. Due to the properties of the film, this may bond the layers together. As an alternative or in addition, the layers may be bonded by an adhesive arranged between each layer. The adhesive should preferably be selected not to dampen the compliance of the multilayer structure. Accordingly, it may be  
25 preferred to select the same material for the film and adhesive, or at least to select an adhesive with a modulus of elasticity being less than the modulus of elasticity of the film.

The composite layers in the multilayer composite should preferably be identical to ensure a homogeneous deformation of the multilayer composite throughout all layers, when an  
30 electrical field is applied. Furthermore, it may be an advantage to provide the corrugated pattern of each layer either in such a way that wave crests of one layer are adjacent to wave crests of the adjacent layer or in such a way that wave crests of one layer are adjacent to troughs of the adjacent layer.

The containment may be conductive and may separate the compliant core from the electrode to enable conduction from the core through the containment to the electrode, whereby the

containment may be able to protect and retain the core, while at the same time enabling conduction from the core to the electrode.

The conductor may be formed as an elongated body like a tradition wire. In another embodiment, the conductor may be formed as a pouch being circular, oval, or of another shape suitable for establishing the electrically communication with one of the electrodes.

In one embodiment, the laminate may be arranged in a spiral configuration and may thereby form a roll with a body extending axially between two end faces. Thus, a very long length of the laminate may thereby be in a more compressed form, while at the same time having a multi-layer composite.

10 The electrodes may have anisotropic stretchability, or anisotropic compliance. The anisotropic compliance/stretchability may be caused by the electrodes which may be formed at a wave shaped surface pattern. This surface pattern may create an electrode with a length in one direction being substantially longer than the length of the laminate as such, and the laminate can therefore be stretched in one direction without stretching the electrode. This provides the

15 compliance in this direction, i.e. the anisotropic stretchability. Conversely, the lack of compliance in other directions can also be provided by the same electrode because it is substantially less elastically deformable than the film. The ratio between a modulus of elasticity of the electrode and a modulus of elasticity of the film may be larger than 200.

A laminate may in one embodiment be rolled relative to the anisotropic stretchability such that an electrical field causes radial expansion or contraction of the roll.

To facilitate conductive communication between the conductor and the electrode, the containment may be formed about a contacted one of the end faces. In one embodiment, the first and second electrodes may each contact a containment at an end face of the roll thereby enabling radial expansion or contraction of the roll in response to an electrical field, i.e. an

25 electrical potential between the two end faces of the roll.

The laminate may be formed so that the one of the electrodes is formed to an edge of the film such that the electrode extends to the contacted end face, such that an outer surface of the containment may be located in plane with the end face and be in electrical contact with the electrode which is terminated at that end face.

30 The other electrode may on the contrary be formed to an edge of the film in the opposite direction such that this electrode extends to the other contacted end face, thereby facilitating contact between the other electrode and the other conductor. Thereby the two electrodes do

only extend to one edge of the film, i.e. to opposite edges so that each of the electrodes is contact with only one conductor. At a middle portion of the film, an overlapping portion of the electrodes exist where the film can be deformed between the electrodes.

To facilitate contact between an electrode and a conductor, the compliant core may be in  
5 direct contact with a surface of one of the first and second electrodes. This may be facilitated by providing an aperture in the containment, the aperture being arranged at the contacted end face of the roll.

In another embodiment, the laminate may be rolled perpendicular to the anisotropic stretchability, whereby an electrical field causes a lengthwise expansion or contraction of the  
10 roll.

In yet another embodiment, a laminate may be folded along the length of the laminate to have a multi-layer composite with a reduced length.

The conductance,  $G$  (I/V), of the containment may be in the range of 1-50 pct. of the conductance,  $G$ , of the compliant core.

15 The elastic elongation of the containment may be in the range of 10-200 pct. of the elastic elongation of the film. By 'elastic elongation' is herein meant, the percentage elongation which can be reached without permanently deforming the polymer material.

In one embodiment, the containment and the film may comprise an identical polymer material.

20 The compliant core may comprise a metal which is liquid at room temperature. The conductor may thus be manufactured at a lower temperature where the metal is solid to facilitate positioning of the containment so that it encloses the core. Subsequently, the conductor may be arranged at room temperature, whereby the core becomes liquid.

25 Additionally, the compliant core may comprise a material selected from the group consisting of: aluminium, copper, nickel, silver, carbon, mercury, and combinations hereof. As mentioned above, the core may comprise fluid, grease, gel, elastomer, powder, pasta, or mixtures hereof, such as a metal powder in a gel, or a conductive carbon powder.

Furthermore, the compliant core may comprise an amorphous alloy, i.e. a non-crystalline alloy. These alloys may contain atoms of significantly different sizes, leading to low free volume in liquid state. Furthermore, these alloys soften and flow upon heating.

5 In one embodiment, the containment may be tubular with an inner lumen extending in an axial direction.

The cross-section of the containment may change along the axial direction. As an example, the cross-section may be substantially circular with an increasing and decreasing area, the outer surface being wave shaped. This may have the advantage, that the containment can be elongated without reducing the cross-sectional area of the inner lumen at the positions it is  
10 thinnest. When the conductor is stretched, the containment deforms by reduction of the cross-sectional area at the positions where the containment is thickest so that the cross-sectional area at these positions may be decreased.

It should be understood, that the cross-sectional area may be of any shape, i.e. the containment may have a non-circular cross-section perpendicular to the axial direction.

15 To reduce the risk of leakage from the containment, if the containment should break or in any other way be damaged, the containment may form a plurality of compartments, each compartment enclosing a compliant core. Thereby it may be ensured, that only the compliant core or parts hereof from a single compartment is leaked in case of damage of the containment.

20 To facilitate that the deformable conductor is current-carrying through out the total length, each compliant core may be in electrical communication with an adjacent compliant core by the conductivity of the containment.

Furthermore, the containment may contain only the compliant core, e.g. by ensuring that the containment does not contain air bubbles or the like, as such bubbles may hinder or reduce  
25 current-carrying along the length of the conductor. Bubbles may especially be a problem during expansion of the conductor, as the cross-sectional area hereof may be decreased during the expansion.

Electrical communication through out the length of the conductor may also be facilitated by choosing a compliant core which comprises an incompressible medium, such as a liquid or a  
30 powder, as the incompressible medium may extend along the full length of the conductor also during expansion hereof.

The transducer may furthermore comprise a control system which is capable of determining an electrical characteristic of the conductor and to determine therefrom, a degree of elongation of the conductor. The electrical characteristic may as an example be resistance, capacitance, inductance, or a combination hereof.

5 In one embodiment of a transducer, at least one of the conductors may be in electrically  
conductive communication with one of the electrodes substantially along a compliant  
direction to enable deflection of the polymer material in response to an electrical field. Thus,  
the conductor itself may be expanded and contracted together with the laminate. The  
conductor may be in electrically conductive communication along the compliant direction  
10 when being positioned parallel to the compliant direction and being positioned within +/- 45  
degrees to compliant direction.

The laminate may be rolled along the compliant direction to form a roll such that an electrical  
field causes radial expansion or contraction of the roll. If the transducer comprises at least  
one of the conductors in electrically conductive communication with one of the electrodes  
15 substantially along a compliant direction, it may thereby be ensured that the conductor does  
not restrict the movement of the roll, as the elastically deformable conductor may expand  
and contract together with the laminate.

To enable an electrical potential between the electrodes, the conductor may be connected to  
a traditional wire. As such a traditional wire is stiff compared to the elastically deformable  
20 conductor, stress may occur about the joint due to the concentration of tension. Such stress  
may weaken the joint.

The conductor may comprise at least two different portions facilitating functions and having  
different elastic properties. Herein these two portions are referred to as a primary portion  
and a transition portion. The transition portion may facilitate connection of the elastically  
25 deformable conductor to a traditional non-elastically deformable wire, and the transition zone  
may be less elastically deformable than the primary portion. The primary portion of the  
conductor should be understood as the portion of the conductor being adhesively and/or  
electrically coupled to one of the electrodes. It should further be understood, that primary is  
not related to size, as the primary portion of the conductor in some embodiments may be  
30 larger than the transition zone and in other embodiments may be smaller than the transition  
zone.

If the conductor is formed as an elongated body, the transition zone may be formed as an  
extension hereto. Furthermore, a conductor being pouch formed, e.g. having a circular

shape, may comprise a transition zone formed as a flange along the circumference or a part hereof of the conductor.

According to a second aspect, the invention provides a conductor comprising a conductive compliant core enclosed in an elongated containment made from an elastomer, wherein the  
5 elastomer is conductive.

It should be understood, that the conductor according to the second embodiment of the invention may comprise any of the features mention above in connection with the first embodiment of the invention, as these features may also be applicable to the conductor of the second aspect of the invention.

10 According to a third aspect, the invention provides a method of making a conductor for an electroactive polymer transducer, the method comprising the steps of:

- providing a core material;
- bringing the core material to a solid state;
- moulding a containment onto the core material by solidifying a polymer material around the  
15 core; and
- bringing the core material to a liquid state.

It should be understood, that the features of the first and second aspect of the invention may also be applicable to the method according the third aspect of the invention.

#### Brief description of the drawings

20 Embodiments of the invention will now be further described with reference to the drawings, in which:

Figs. 1a and 1b illustrate an example of a laminate,

Figs. 2a and 2b illustrate an example of a conductor connected to a laminate,

Figs. 3a and 3b illustrate an example of a conductor connected to a laminate,

25 Figs. 4a and 4b illustrate a transducer comprising a conductor connected to a laminate according to the invention,

Figs. 5a and 5b illustrate two different configurations of a rolled laminate,

Figs. 6a-6d illustrate different embodiments of transducer,

Figs. 7a-7d illustrate the transducers of Figs. 6a-6b with a protective coating,

Figs. 8a and 8b illustrate a transducer comprising a conductor connected to a rolled laminate,

5 Fig. 9 illustrate a transducer comprising a conductor connected to an alternative embodiment of a rolled laminate,

Fig. 10 illustrates a transducer comprising a conductor comprising a transition zone, the conductor being connected to a rolled laminate,

10 Fig. 11 illustrates a transducer comprising a conductor comprising a transition zone, the conductor being connected to a laminate,

Fig. 12 and Fig. 13 illustrate conductors, and

Figs. 14a-14c illustrate a conductor.

#### Detailed description of the drawings

15 It should be understood that the detailed description and specific examples, while indicating embodiments of the invention, are given by way of illustration only, since various changes and modifications within the spirit and scope of the invention will become apparent to those skilled in the art from the detailed description.

20 Figs. 1a and 1b illustrate a laminate 1 comprising a film 2 of a dielectric polymer material arranged between first and second electrodes 3, 4. In Fig. 1a the laminate 1 is exposed to zero electrical potential difference, and in Fig. 1b the laminate 1 is exposed to a high electrical potential difference. As illustrated in Fig. 1b, the film 2 is expanded, while the electrodes 3, 4 are evened out, when exposed to an electrical potential difference.

25 The laminate 1 comprises a film 2 made of a dielectric material having an upper and lower surface provided with a pattern of raised and depressed surface portions, thereby forming a designed corrugated profile of the surface. An electrically conductive layer has been applied to the upper and lower surface, the electrically conductive material being deposited so that

the electrically conductive layer is formed according to the pattern of raised and depressed surface portions, thereby forming a first and second electrode 3, 4 on opposite sides of the film 2. In terms of everyday physical things, the film 2 resembles in some aspects household wrapping film. It has a similar thickness and is comparably pliable and soft. However, it is more elastic than such a film, and has a marked mechanical anisotropy as will be explained in the following.

The dielectric material may be an elastomer or another material having similar characteristics.

Due to the pattern of raised and depressed surface portions, the electrodes 3, 4 may even out as the film 2 expands, and recover its original shape as the film 2 contracts along the direction defined by the arrow 5 without causing damage to the electrodes 3, 4, this direction thereby defining a direction of compliance. Accordingly, the laminate 1 is adapted to form part of a compliant structure capable of withstanding large strains.

As described above, the corrugated surface profile is directly impressed or moulded into the dielectric film 2, before the electrically conductive layer is deposited. The corrugation allows the manufacturing of a compliant composite using electrode materials of high elastic moduli, e.g. metal electrode. This can be obtained without having to apply pre-stretch or pre-strain to the dielectric film 2 while applying the electrically conductive layer, i.e. the electrodes 3, 4, and the corrugated profile of the finished composite 1 does not depend on strain in the dielectric film 2, nor on the elasticity or other characteristics of the electrodes 3, 4.

Accordingly, the corrugation profile is replicated over substantially the entire upper and lower surfaces of the film 2 in a consistent manner, and it is possible to control this replication. Furthermore, this approach provides the possibility of using standard replication and reel-to-reel coating, thereby making the process suitable for large-scale production. For instance, the electrodes 3, 4 may be applied to the upper and lower surfaces of the dielectric film 2 using standard commercial physical vapour deposition (PVD) techniques. An advantage of this approach is that the anisotropy is determined by design, and that the actual anisotropy is obtained as a consequence of characteristics of the corrugated profile which is provided on the surfaces of the film 2 and the electrodes 3, 4 which follow the corrugated profile.

The laminate 1 shown in Figs. 1a and 1b is designed to have a compliance in the range of the compliance of the film 2 in the direction defined by the arrow 5, and a stiffness in the range of the stiffness of the electrodes 3, 4 in a direction defined by the arrow 6. In Figs. 1a and 1b, the compliance direction is along the length of the composite 1.

Figs. 2a and 2b illustrate conductors 7a, 7b connected to a laminate 1, the conductors 7 being in electrically conductive communication with the electrodes 3, 4 to facilitate an electrical potential between the electrodes and thereby enable deflection of the film 2 in response to an electrical field. The conductors 7 are connected to the film in the direction where the laminate is constraint, i.e. perpendicular to the compliant direction illustrated by the arrow 5. Consequently, the conductors 7 are typically made of a stiff material, such as aluminium alloys, copper foils, and the like. However, a drawback of this connection is that the resistance along the compliance direction may become too high, especially when the laminate is long.

10 Figs. 3a and 3b illustrate conductors 7a, 7b connected to a laminate 1, the conductors 7 being in electrically conductive communication with the electrodes 3, 4 to facilitate an electrical potential between the electrodes and thereby enable deflection of the film 2 in response to an electrical field. The conductors 7 are connected to the laminate 1 in the direction where the laminate is compliant (indicated by the arrow 5). Consequently, the conductors 7 have to be stretchable to be able to follow the deflection of the film 2 in the lengthwise direction, i.e. along the compliance length, when an electrical potential between the electrodes 3, 4 causes the deflection. Typically, the conductors 7 are made from a soft, stretchable conductive polymer having a resistance, resulting in a high resistance of the system even though the resistance of the electrodes is very low.

20 Figs. 4a and 4b illustrate a transducer 8 comprising conductors 7a, 7b connected to a laminate 1 according to the invention. The conductors 7 are in electrically conductive communication with the electrodes 3, 4 to facilitate an electrical potential between the electrodes and thereby enable deflection of the film 2 in response to an electrical field. The conductors 7 are connected to the laminate 1 in the direction where the laminate is compliant (indicated by arrow 5). In order to obtain stretchable conductors 7 being able to carry the current into the electrode along the length of the laminate, the conductors 7 comprise a conductive compliant core 9 enclosed in a containment 10 having elastomeric properties. Even though the containment 10 is made from an elastomer with a high resistance, the resulting resistance of the conductors 7 are low due to the low thickness of the containment 10 in combination with the conductive core 9 having a low resistance. The core may be made of a fluid or powder, e.g. of carbon powder or a metal powder in a gel. Thus, the containment 10 may encapsulate the compliant core 9.

Thus, the system may be designed to have a substantially constant resistance during stretching of the laminate, as the resistance of the core increases due to the stretching and as the resistance of the containment is reduced when the containment is stretched.

Figs. 5a and 5b illustrate two different configurations of a rolled laminate 1. In Fig. 5a, the compliance direction (see arrow 5) is along the length of the laminate 1, whereas the compliance direction of Fig. 5b is across the laminate 1. This is indicated by the thin lines across the composite 1 in Fig. 5a and along the composite 1 in Fig. 5b, which thin lines  
5 represent the pattern of raised and depressed surface portions forming the corrugated profile. The laminate 1 may be produced in very long lengths, so called "endless" laminates which may be stored as spools as shown in Figs. 5a and 5b. Such semi finished goods may be used for the production of transducers and the like, e.g. actuators.

Figs. 6a-6d illustrate different embodiments of transducer 8, in which the transducer 8a is the most simple one. The transducers 8a-8d all comprise a rolled laminate 1 and conductors  
10 7. Only one conductor 7 is illustrated in the figures, as the other conductor is in electrical conductive communication with an electrode at the other end of the rolled laminate. Only one of the electrodes 3, 4 is illustrated in the figures as only the first electrode 3 is formed to an edge of the film 2 such that the electrode 3 extends to the contacted end face of the rolled  
15 laminate, such that an outer surface of the containment 10 (not shown) is located in plane with the end face and is in electrical contact with the electrode 3 being terminated at that end face.

The other electrode 4 (not shown) is on the contrary formed to an edge of the film 2 in the opposite direction such that this electrode extends to the other contacted end face, thereby  
20 facilitating contact between the other electrode 4 and the other conductor (not shown). Thereby the two electrodes 3, 4 do only extend to one edge of the film, i.e. to opposite edges so that each of the electrodes 3, 4 is contact with only one conductor 7. At a middle portion of the film 2, an overlapping portion of the electrodes exists where the film 2 can be deformed between the electrodes 3, 4.

25 The transducer 8a comprises a conductive core 9 with conductance  $G$ , and a rolled laminate 1 comprising a film 2 and an electrode 3.

In Fig. 6b, the transducer 8b is formed so that a part of the compliant conductive core 9 of the conductor 7 is positioned between the film 2 and the electrode 3 of the rolled laminate 1. A non-conductive elastic seal 11 is provided in the gab.

30 In Fig. 6c, a conductive containment 10 is provided at the end face of the rolled laminate 1. A part of the conductive containment 10 is furthermore positioned in a gab between the film 2 and the electrode 3 of the rolled laminate 1.

In the embodiment of the transducer 8d illustrated in Fig. 6d, an additional conductive containment 13 is provided at the end face of the rolled laminate 1.

Figs. 7a-7d illustrate the transducers 8a-8b of Figs. 6a-6b with a protective coating 14 encapsulating the conductor and the end face of the laminate.

- 5 Fig. 8b illustrates a transducer 8 comprising a conductor 7 connected to a rolled laminate 1. Fig. 8a illustrates the rolled laminate 1 before connection of the conductor 7. In the illustrated embodiment, the conductor 7 has an elongated structure. Due to the elastical deformability of the conductor 7, it can be rolled and bended (see Fig. 8b) to ensure electrically conductive communication with an electrode (not shown).
- 10 As illustrated, the laminate is rolled relative to the anisotropic stretchability illustrated by the thin lines such that an electrical field causes radial expansion or contraction of the roll as indicated by the arrows 5. Due to the elastically deformable the conductor 7, it can be ensured that the conductor 7 does not restrict the movement of the roll, as the conductor 7 expands and contracts together with the rolled laminate 1.
- 15 In order to enable an electrical potential between the electrodes, the conductor 7 is connected to a traditional wire 14 via a joint 15.

Fig. 9 illustrates another embodiment of a transducer 8 comprising a conductor 7 connected to a laminate 1 being rolled in the lengthwise direction, whereby an electrical field causes a lengthwise expansion or contraction of the roll as indicated by the arrows 5. Due to the  
20 elastically deformable conductor 7, the conductor 7 expands and contracts together with the rolled laminate 1.

In order to enable an electrical potential between the electrodes, the conductor 7 is connected to a traditional wire 14 via a joint 15.

Fig. 10 illustrates a transducer 8 comprising a conductor 7 and a rolled laminate 1. The  
25 transducer 8 is similar to the transducer illustrated in Figs. 8a and 8b. To enable an electrical potential between the electrodes, the conductor 7 is connected to a traditional wire 14 via a joint 15.

As such a traditional wire 14 is stiff compared to the elastically deformable conductor 7, stress may occur about the joint due to the concentration of tension. Such stress may  
30 weaken the joint.

The conductor 7 therefore comprises two different portions, a primary portion 7' and a transition portion 16. The transition portion 16 facilitates connection of the elastically deformable conductor 7 to the traditional non-elastically deformable wire 14. The transition zone 16 is less elastically deformable than the primary portion 7'. The primary portion 7' of the conductor is the portion of the conductor 7 being adhesively and/or electrically coupled to one of the electrodes (not shown).

Fig. 11 illustrates another embodiment of a transducer 8 comprising a conductor 7 having a transition zone 16 for connection to a traditional wire 14.

Fig. 12 and Fig. 13 illustrate conductors 7 comprising a compliant core 9 being enclosed in a containment 10. The conductor 7 is connected to a traditional wire 14 via a joint 15. The transition zone 16 is not shown in these figures.

In Figs. 12 and 13, the containment 10 comprises two compartments, each comprising a compliant core 9. In Fig. 13, openings are provided in the containment to allow for direct contact between the compliant core 9 and the electrode (not shown).

Figs. 14a-14c illustrate a conductor 7. Figs. 14a and 14b illustrate one example of how to assemble a conductor 7 comprising a compliant core 9 enclosed in a containment with a traditional wire 14 via a joint 15.

In Fig. 14c it is illustrated how the conductor 7 is extended together with the laminate (not shown) in response to an electrical field causing an expansion of the laminate.

## CLAIMS

1. A transducer comprising conductors and a laminate, the laminate comprising a film of a dielectric polymer material arranged between first and second electrodes, and each electrode being in electrically conductive communication with at least one of the conductors to facilitate an electrical potential between the electrodes and thereby enable deflection of the polymer material in response to an electrical field, wherein at least one of the conductors is an elastically deformable conductor comprising a compliant core which is electrically conductive, the core being enclosed in a containment having elastomeric properties.  
5
2. A transducer according to claims 1, wherein the containment is conductive and separates the compliant core from the electrode to enable conduction from the core through the containment to the electrode.  
10
3. A transducer according to claim 2, wherein the laminate is arranged in a spiral configuration and thereby forms a roll with a body extending axially between two end faces.
4. A transducer according to any of the preceding claims, wherein the electrodes have anisotropic stretchability.  
15
5. A transducer according to claims 3 and 4, wherein the laminate is rolled relative to the anisotropic stretchability such that an electrical field causes radial expansion or contraction of the roll.
6. A transducer according to any of claim 3-5, wherein the containment is formed about a contacted one of the end faces.  
20
7. A transducer according to any of claims 3-6, wherein one of the electrodes is formed to an edge of the film such that the electrode extends to the contacted end face.
8. A transducer according to any of the preceding claims, wherein the compliant core is in direct contact with a surface of one of the first and second electrodes.
9. A transducer according to any of the preceding claims, wherein the conductance,  $G$  (I/V), of the containment is in the range of 1-50 pct. of the conductance,  $G$ , of the compliant core.  
25
10. A transducer according to any of the preceding claims, wherein the elastic elongation of the containment is in the range of 10-200 pct. of the elastic elongation of the film.

11. A transducer according to any of the preceding claims, wherein the containment and the film comprises an identical polymer material.
12. A transducer according to any of the preceding claims, wherein the compliant core comprises a metal which is liquid at room temperature.
- 5 13. A transducer according to any of the preceding claims, wherein the compliant core comprises a material selected from the group consisting of: aluminium, copper, nickel, silver, carbon, mercury, and combinations hereof.
14. A transducer according to any of the preceding claims, wherein the compliant core comprises an amorphous alloy.
- 10 15. A transducer according to any of the preceding claims, wherein the containment is tubular with an inner lumen extending in an axial direction.
16. A transducer according to claim 15, wherein the containment has a cross-section which changes along the axial direction.
- 15 17. A transducer according to any of claims 15 or 16, wherein the containment has a non-circular cross-section perpendicular to the axial direction.
18. A transducer according to any of the preceding claims, wherein the containment forms a plurality of compartments, each compartment enclosing a compliant core.
19. A transducer according to claim 18, wherein each compliant core is in electrical communication with adjacent compliant core by the conductivity of the containment.
- 20 20. A transducer according to any of the preceding claims, wherein the containment contains only the compliant core.
21. A transducer according to any of the preceding claim, wherein the compliant core comprises an incompressible medium.
- 25 21. A transducer according to any of the preceding claims, further comprising a control system capable of determining an electrical characteristic of the conductor and to determine therefrom, a degree of elongation of the conductor.

22. A transducer according to any of the preceding claims, wherein at least one of the conductors is in electrically conductive communication with one of the electrodes substantially along a compliant direction to enable deflection of the polymer material in response to an electrical field.

5 23. A transducer according to claim 22, wherein the laminate is rolled along the compliant direction to form a roll such that an electrical field causes radial expansion or contraction of the roll.

24. A transducer according to any of the preceding claims, wherein the conductor comprises a transition zone which is less elastically deformable than a primary portion of the conductor.

10 25. A conductor comprising a conductive compliant core enclosed in an elongated containment made from an elastomer, wherein the elastomer is conductive.

26. A method of making a conductor for an electroactive polymer transducer, the method comprising the steps of:

- providing a core material;
- 15 - bringing the core material to a solid state;
- moulding a containment onto the core material by solidifying a polymer material around the core; and
- bringing the core material to a liquid state.

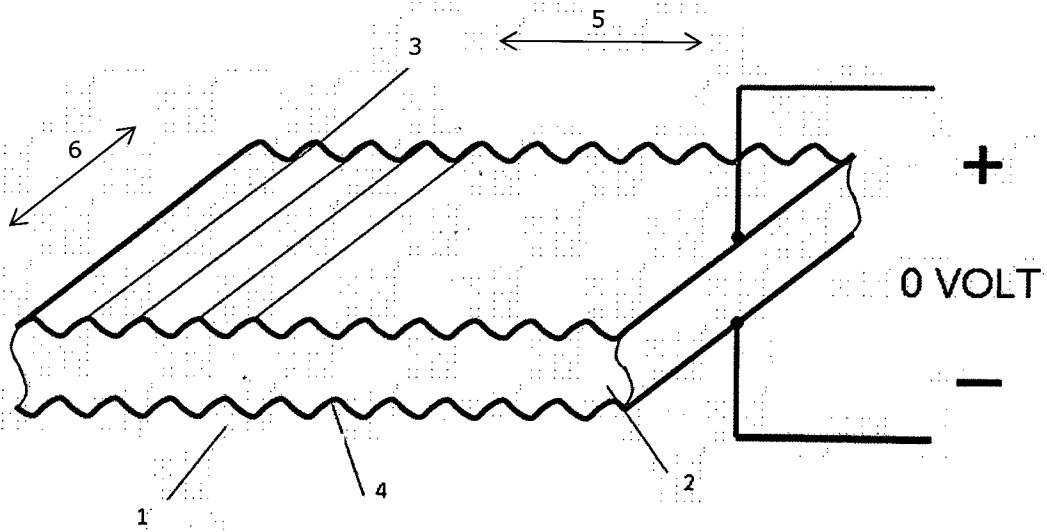

Fig. 1a

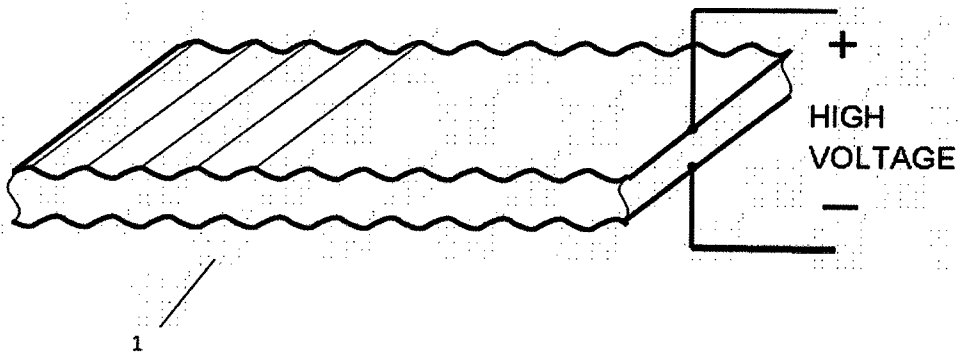

Fig. 1b

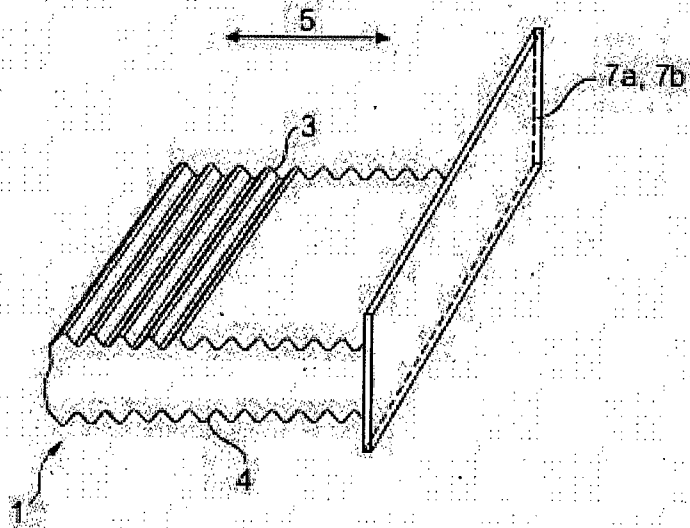

Fig. 2a

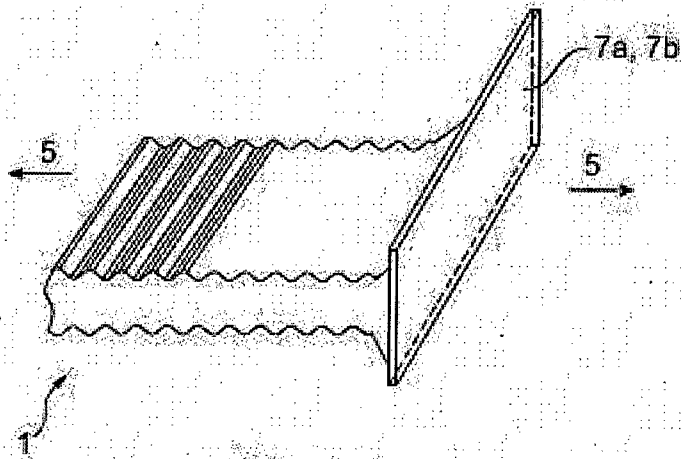

Fig. 2b

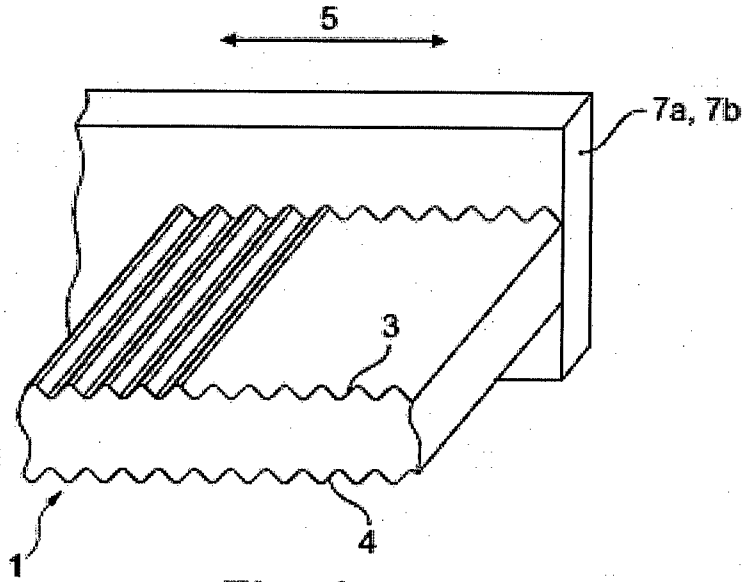

Fig. 3a

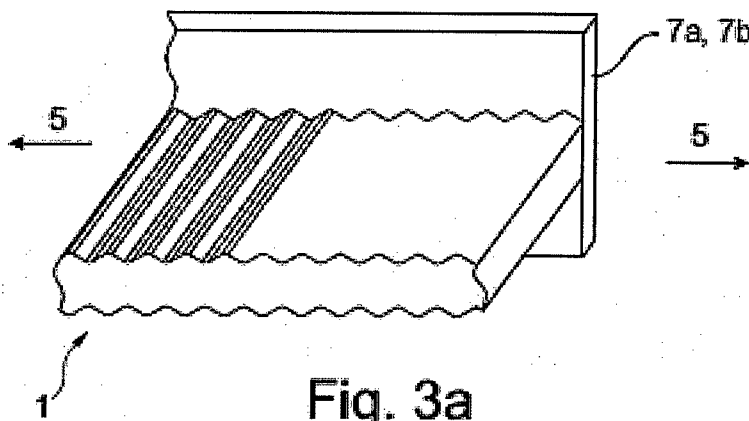

Fig. 3a

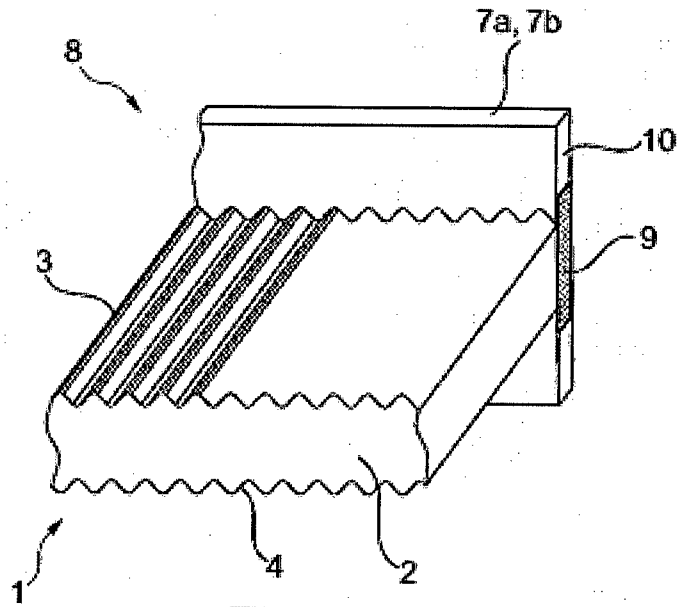

Fig. 4a

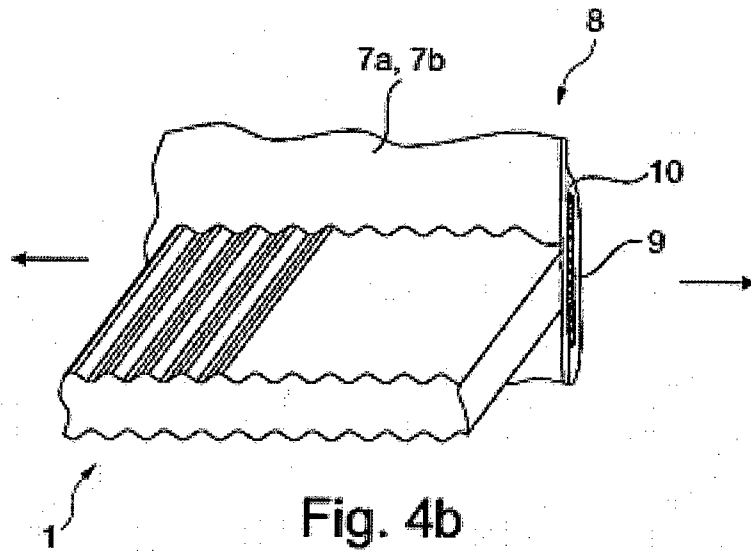

Fig. 4b

5 / 14

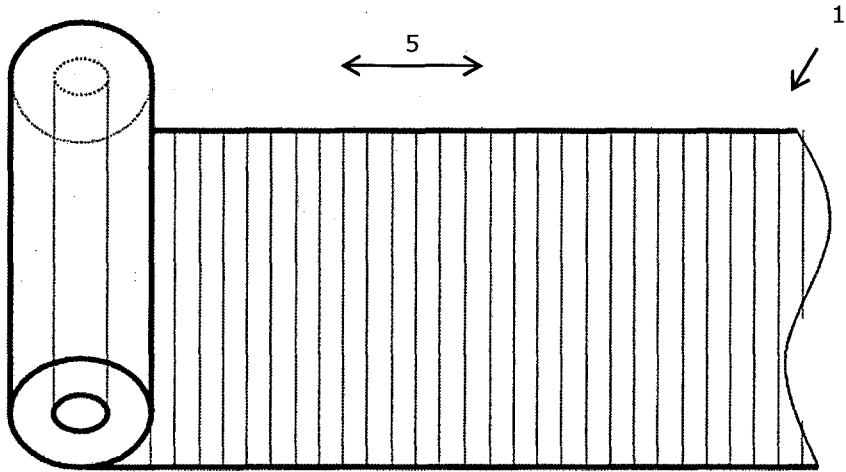

Fig. 5a

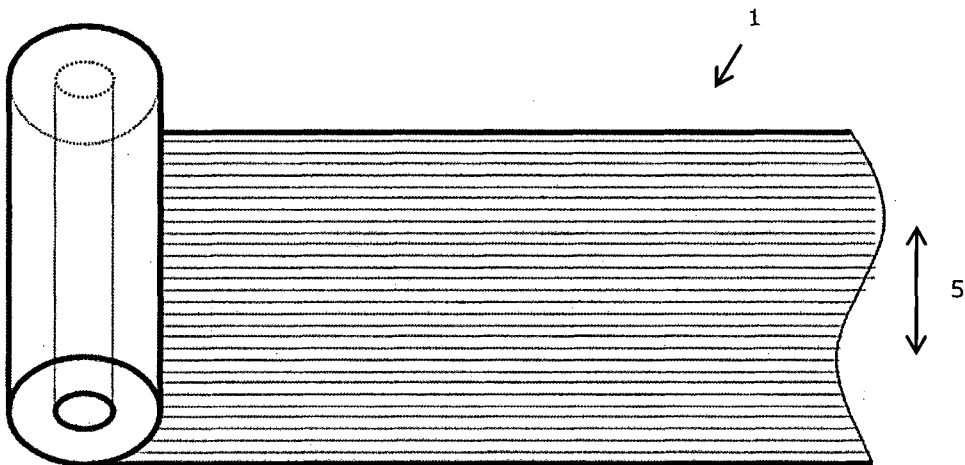

Fig. 5b

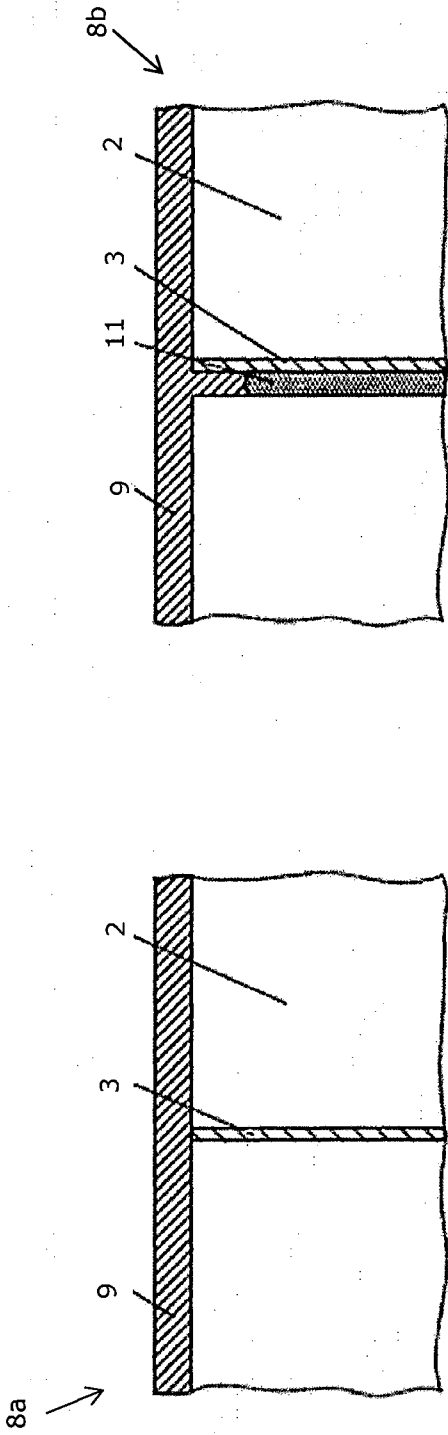

Fig. 6b

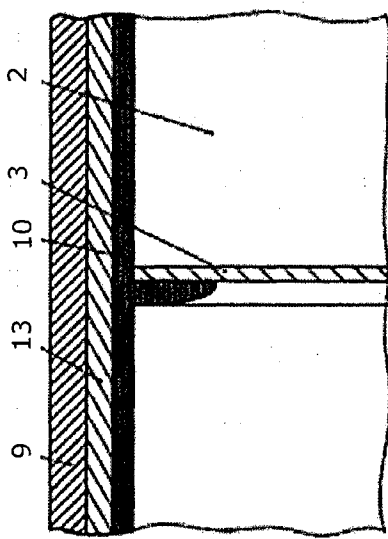

Fig. 6d

Fig. 6a

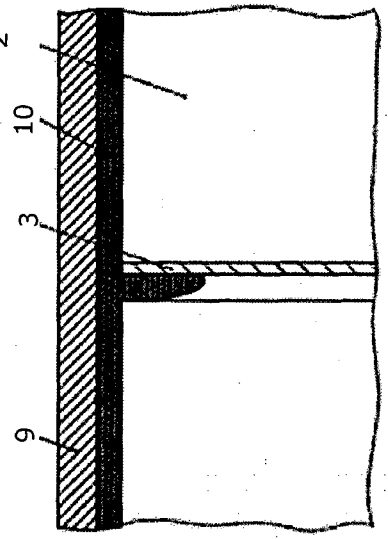

Fig. 6c

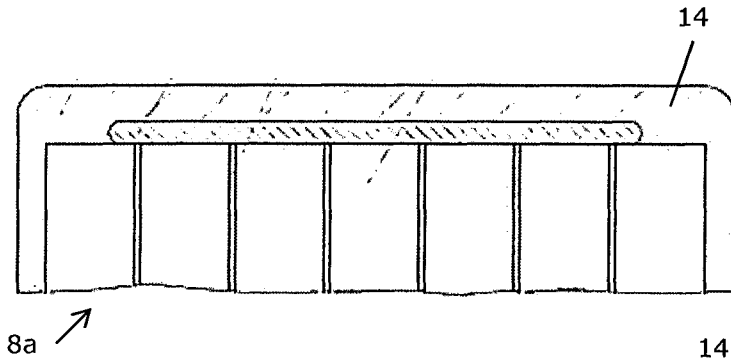

Fig. 7a

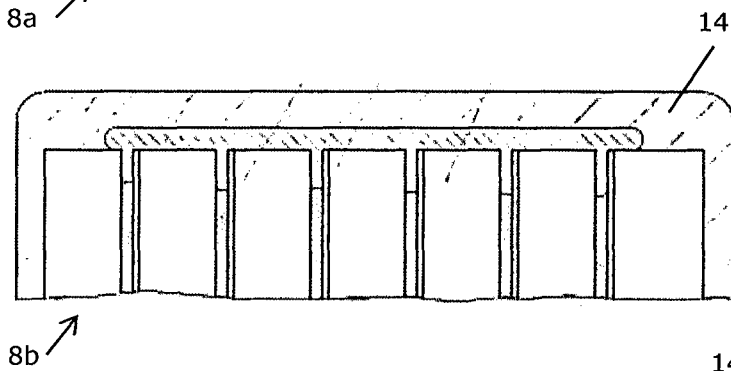

Fig. 7b

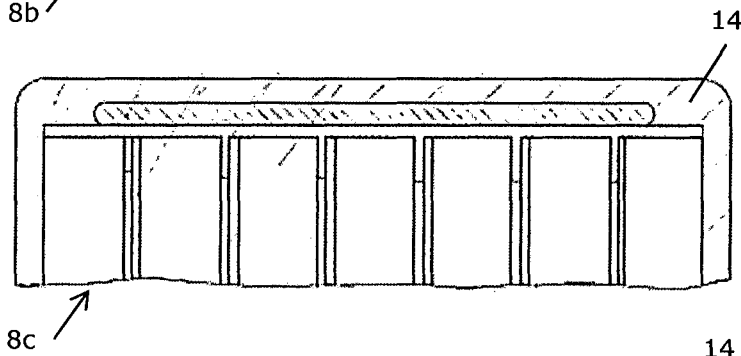

Fig. 7c

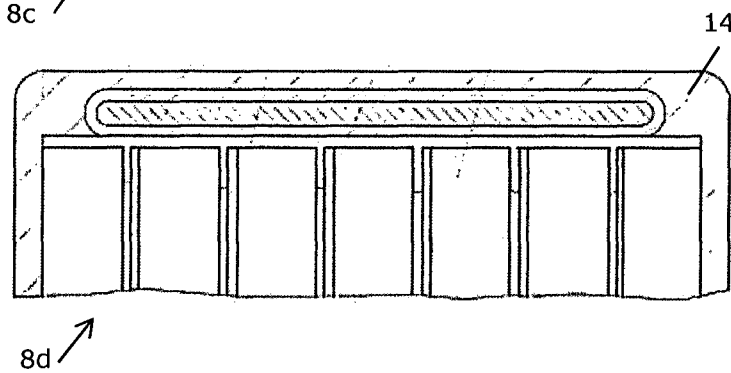

Fig. 7d

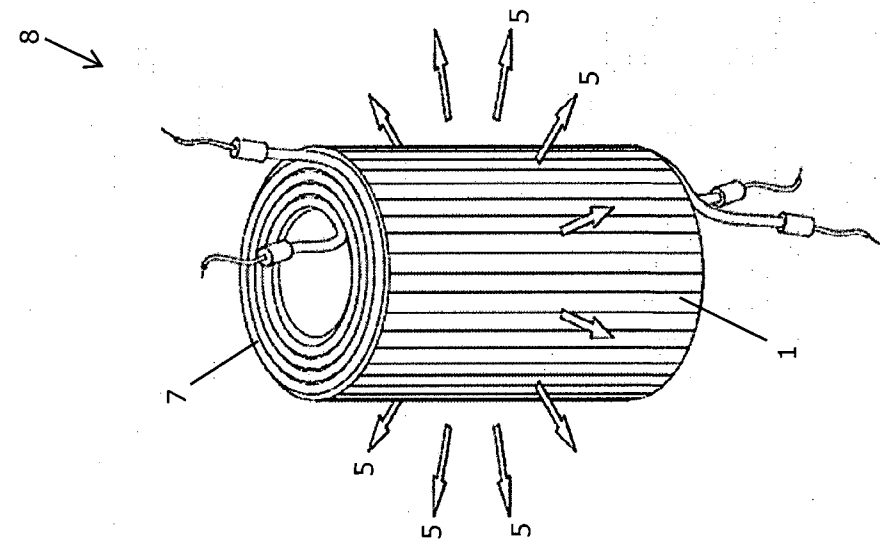

Fig. 8b

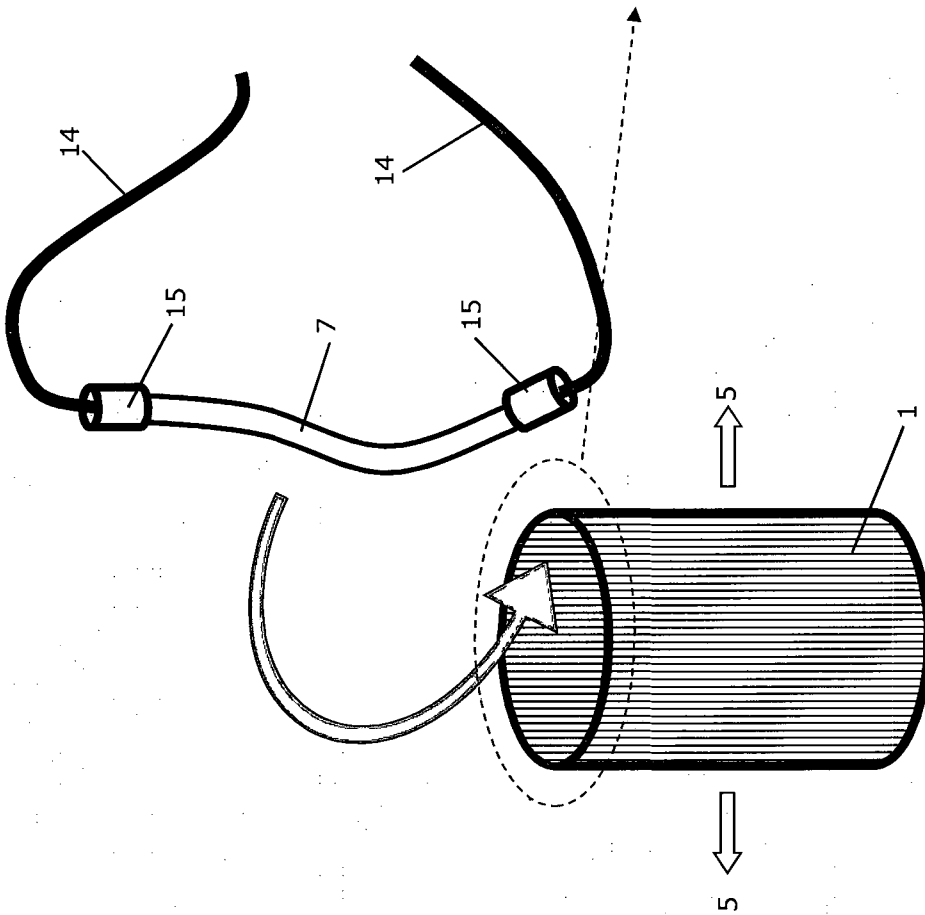

Fig. 8a

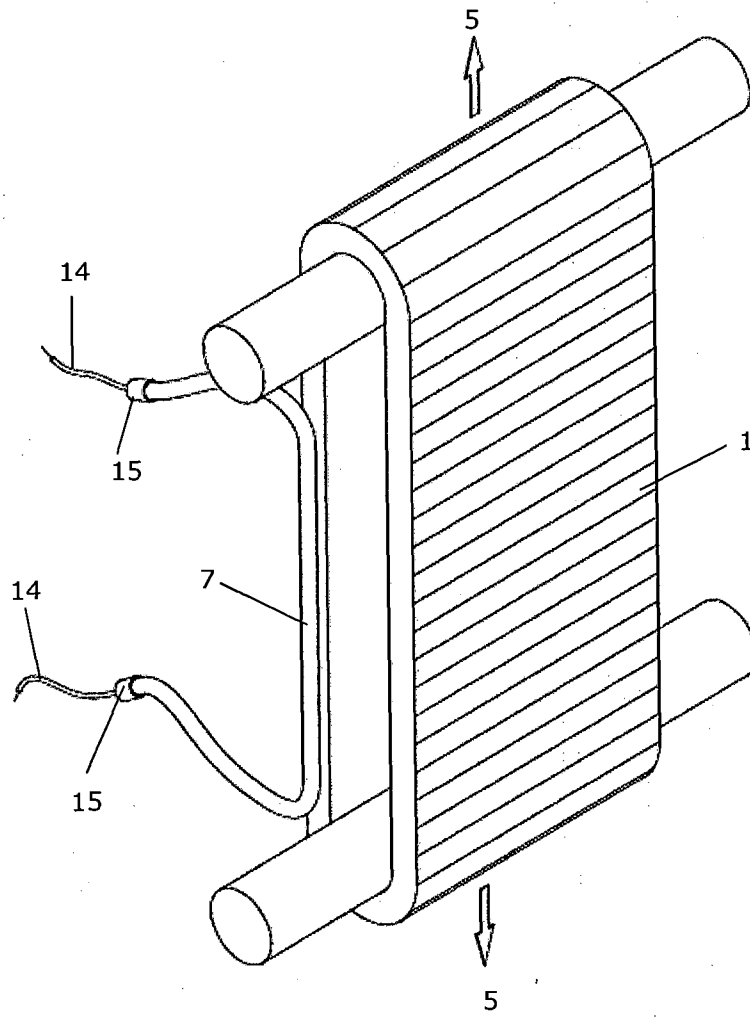

Fig. 9

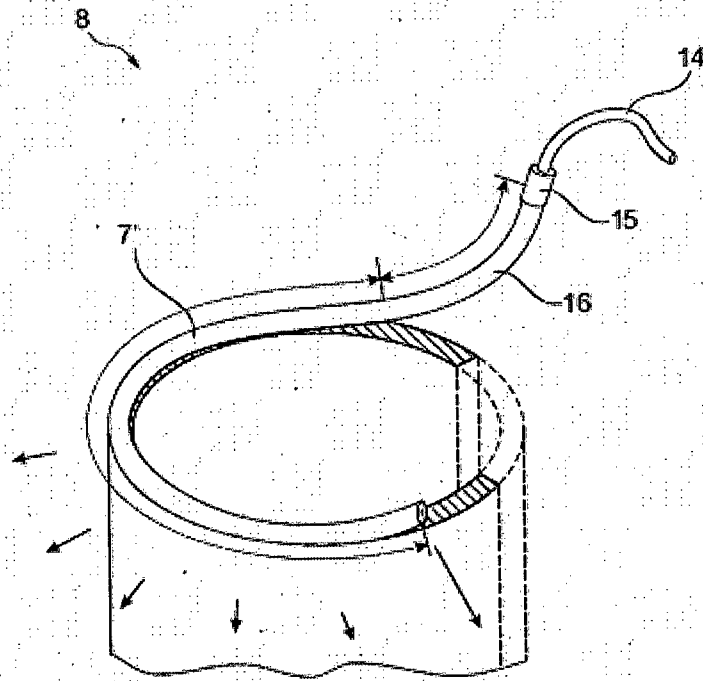

Fig. 10

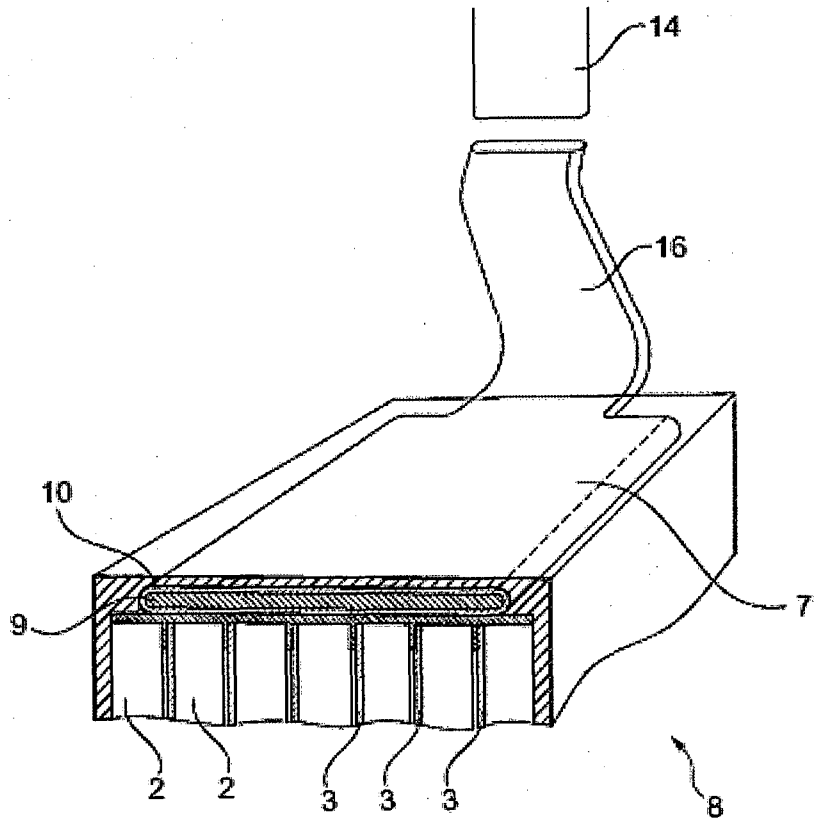

Fig. 11

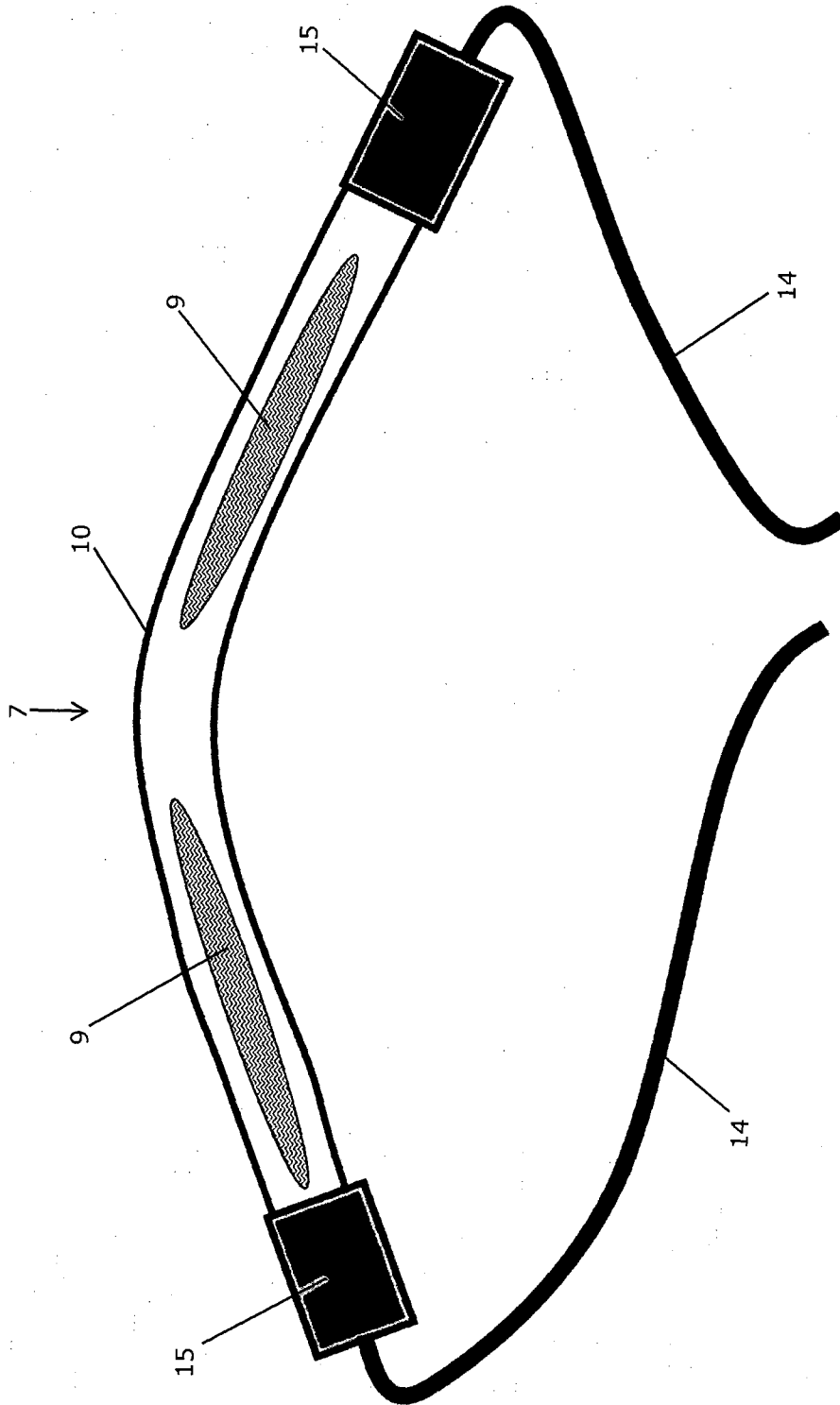

Fig. 12

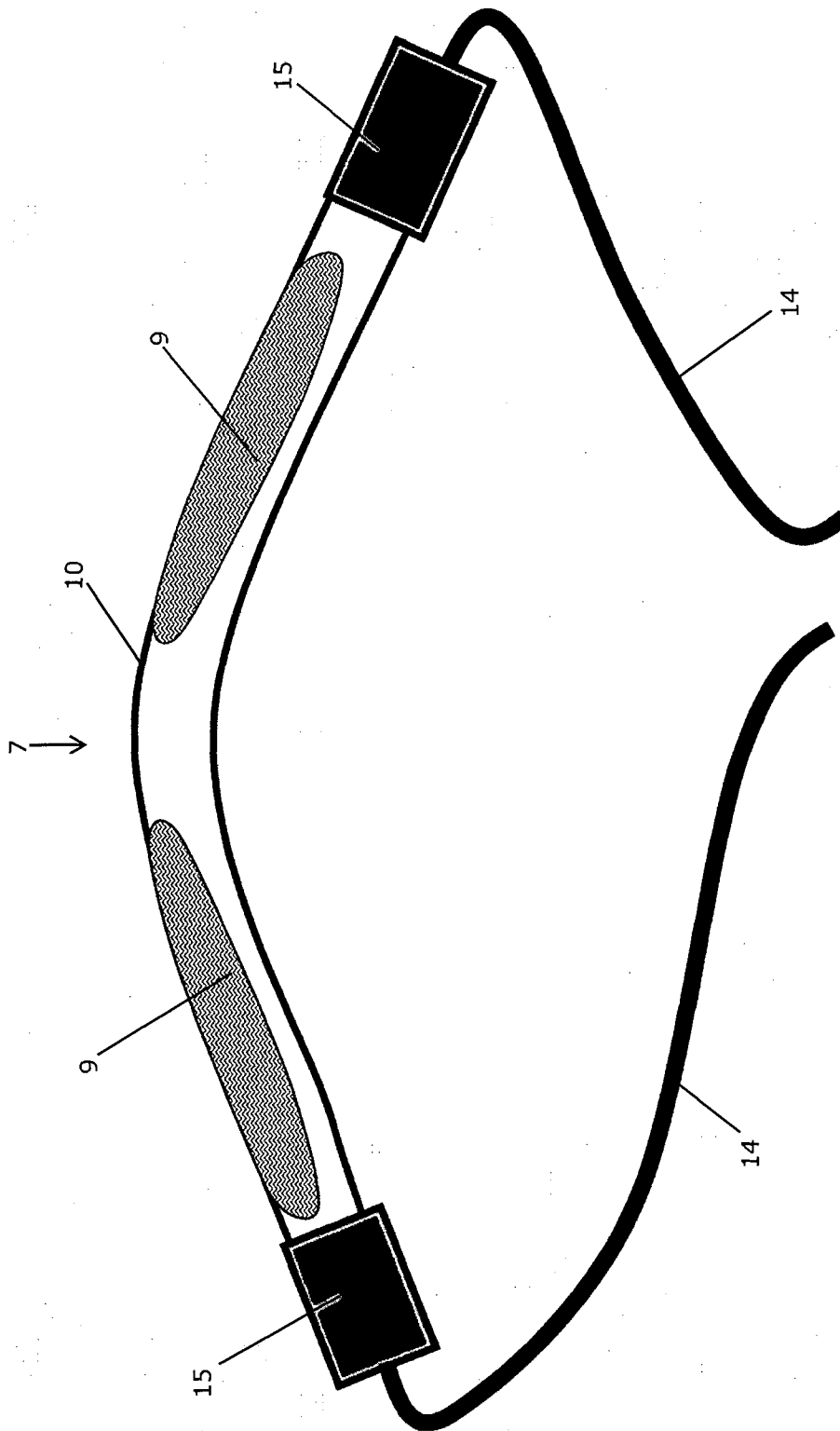

Fig. 13

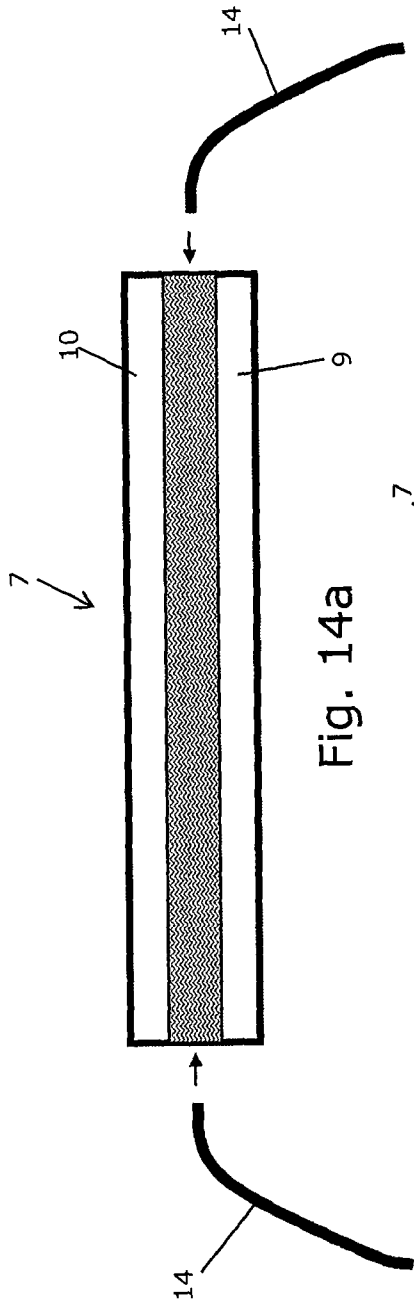

Fig. 14a

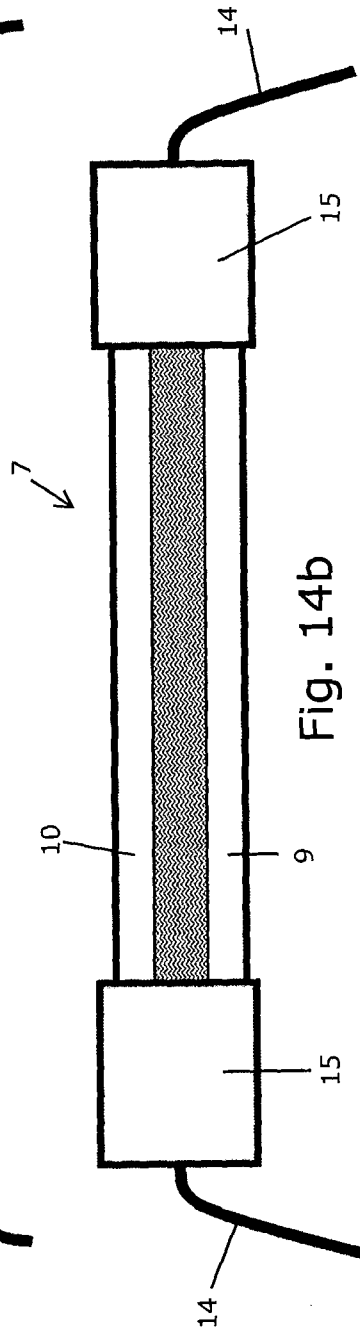

Fig. 14b

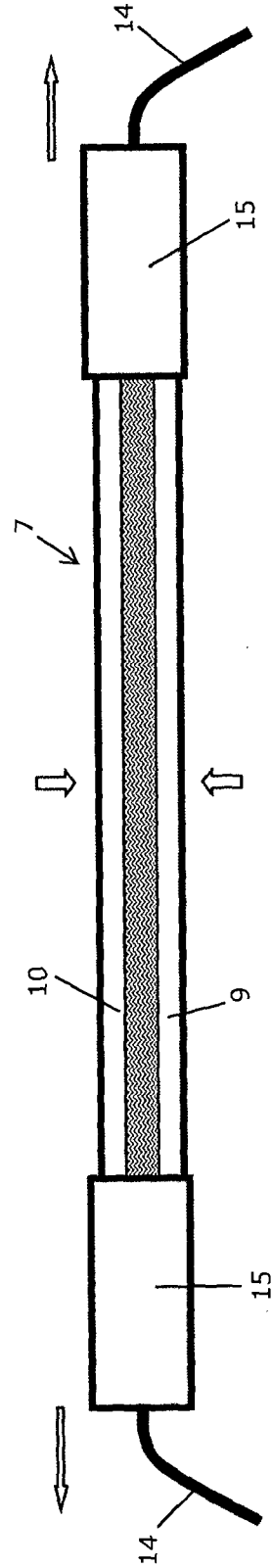

Fig. 14c

INTERNATIONAL SEARCH REPORT

International application No  
PCT/DK2013/000014

A. CLASSIFICATION OF SUBJECT MATTER  
INV. H01L41/047 H01L41/083 H01L41/193 H01L41/293  
ADD.  
According to International Patent Classification (IPC) or to both national classification and IPC

B. FIELDS SEARCHED  
Minimum documentation searched (classification system followed by classification symbols)  
H01L B41J B06B H01H

Documentation searched other than minimum documentation to the extent that such documents are included in the fields searched

Electronic data base consulted during the international search (name of data base and, where practicable, search terms used)  
EPO-Internal, INSPEC, WPI Data

C. DOCUMENTS CONSIDERED TO BE RELEVANT

Category*	Citation of document, with indication, where appropriate, of the relevant passages	Relevant to claim No.
Y A	EP 2 136 419 A2 (BOSCH GMBH ROBERT [DE]) 23 December 2009 (2009-12-23) paragraph [0017] - paragraph [0027]; figures 1-3	1-14, 18-27 15-17
Y A	----- S00-LIM CHUA ET AL: "Multi-walled carbon nanotubes (MWCNT) as compliant electrodes for dielectric elastomer actuators", PROCEEDINGS OF SPIE, vol. 7976, 24 March 2011 (2011-03-24), page 79760V, XP055062885, ISSN: 0277-786X, DOI: 10.1117/12.880486 abstract; figure 1	1-14, 18-27 15-17
A	----- WO 2008/156166 A1 (PANASONIC ELEC WORKS CO LTD [JP]; YOSHIOKA SHINGO [JP]) 24 December 2008 (2008-12-24) figure 6	1-27

Further documents are listed in the continuation of Box C.

See patent family annex.

\* Special categories of cited documents :

- "A" document defining the general state of the art which is not considered to be of particular relevance
- "E" earlier application or patent but published on or after the international filing date
- "L" document which may throw doubts on priority claim(s) or which is cited to establish the publication date of another citation or other special reason (as specified)
- "O" document referring to an oral disclosure, use, exhibition or other means
- "P" document published prior to the international filing date but later than the priority date claimed

- "T" later document published after the international filing date or priority date and not in conflict with the application but cited to understand the principle or theory underlying the invention
- "X" document of particular relevance; the claimed invention cannot be considered novel or cannot be considered to involve an inventive step when the document is taken alone
- "Y" document of particular relevance; the claimed invention cannot be considered to involve an inventive step when the document is combined with one or more other such documents, such combination being obvious to a person skilled in the art
- "&" document member of the same patent family

Date of the actual completion of the international search  
14 May 2013

Date of mailing of the international search report  
31/05/2013

Name and mailing address of the ISA/  
European Patent Office, P.B. 5818 Patentlaan 2  
NL - 2280 HV Rijswijk  
Tel. (+31-70) 340-2040,  
Fax: (+31-70) 340-3016

Authorized officer  
Gröger, Andreas

# INTERNATIONAL SEARCH REPORT

Information on patent family members

International application No

PCT/DK2013/000014

Patent document cited in search report	Publication date	Patent family member(s)	Publication date	
EP 2136419	A2	23-12-2009	DE 102008002489 A1	24-12-2009
			EP 2136419 A2	23-12-2009
-----				
WO 2008156166	A1	24-12-2008	NONE	
-----				