



US 20070213833A1

(19) **United States**

(12) **Patent Application Publication**  
Mears et al.

(10) **Pub. No.: US 2007/0213833 A1**

(43) **Pub. Date: Sep. 13, 2007**

(54) **METHOD AND APPARATUS FOR PERFORMING A MINIMALLY INVASIVE TOTAL HIP ARTHROPLASTY**

(75) Inventors: **Dana Mears**, Loudonville, NY (US);  
**Kevin Greig**, Leesburg, IN (US); **Paul A. Zwirkoski**, Brighton, MI (US)

Correspondence Address:  
**ZIMMER TECHNOLOGY - BAKER & DANIELS**  
111 EAST WAYNE STREET, SUITE 800  
FORT WAYNE, IN 46802 (US)

(73) Assignee: **ZIMMER TECHNOLOGY, INC.**, Chicago, IL (US)

(21) Appl. No.: **11/749,910**

(22) Filed: **May 17, 2007**

**Related U.S. Application Data**

(60) Division of application No. 10/952,301, filed on Sep. 28, 2004, which is a division of application No. 09/992,639, filed on Nov. 6, 2001, now Pat. No. 6,860,903, which is a continuation-in-part of application No. 09/558,044, filed on Apr. 26, 2000, now Pat. No. 6,676,706.

**Publication Classification**

(51) **Int. Cl.**  
*A61F 2/36* (2006.01)  
(52) **U.S. Cl.** ..... **623/23.11**

(57) **ABSTRACT**  
A method and apparatus for performing a minimally invasive total hip arthroplasty. The apparatus may include a provisional femoral head allowing for radial placement thereof on a provisional femoral neck.

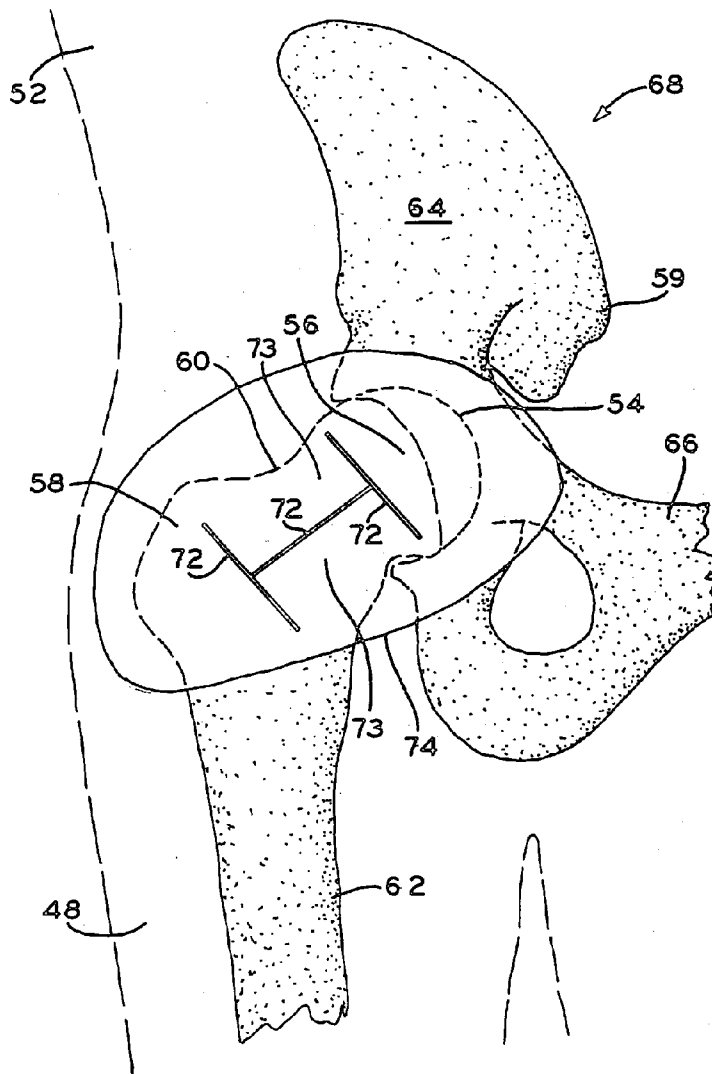

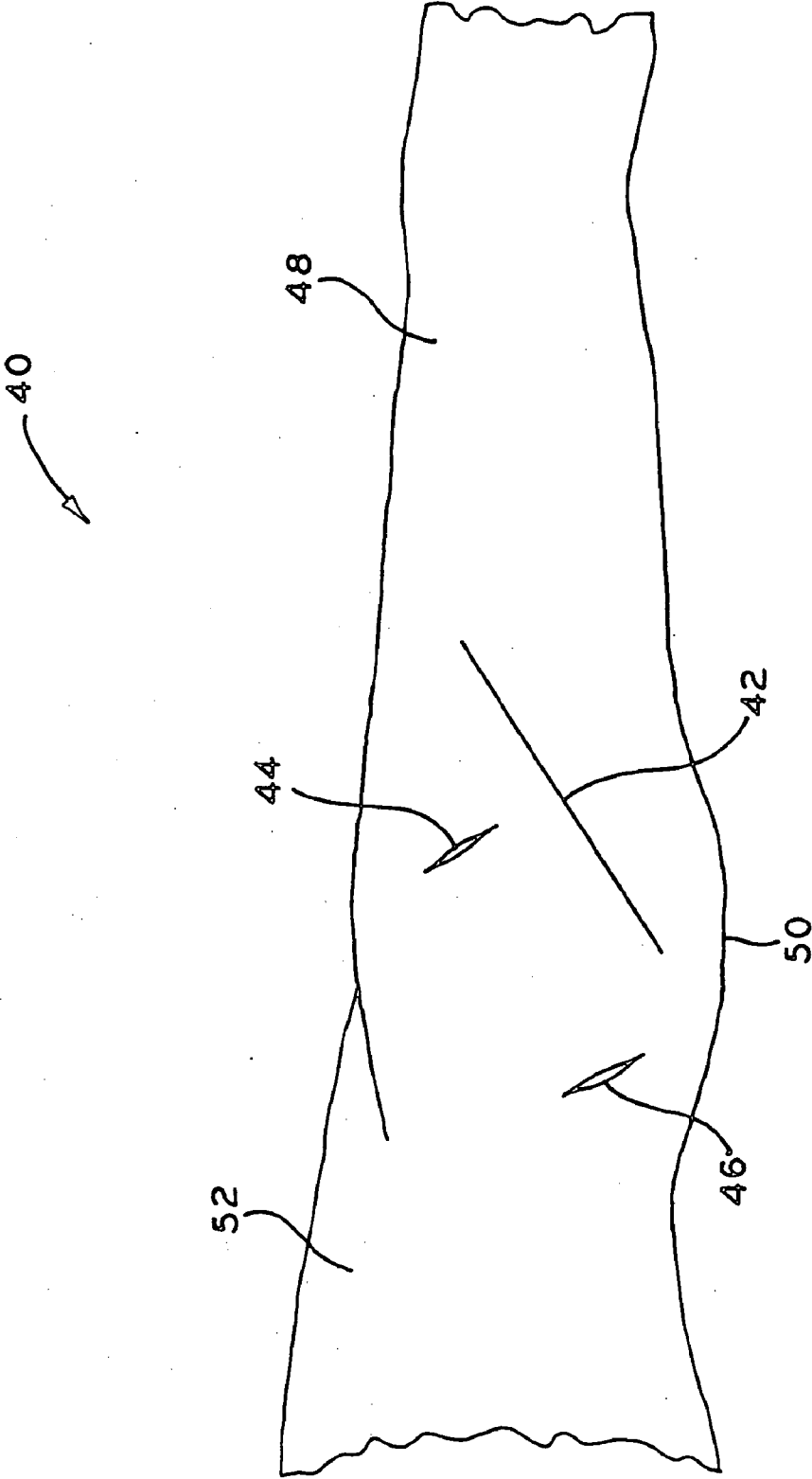

FIG. 1

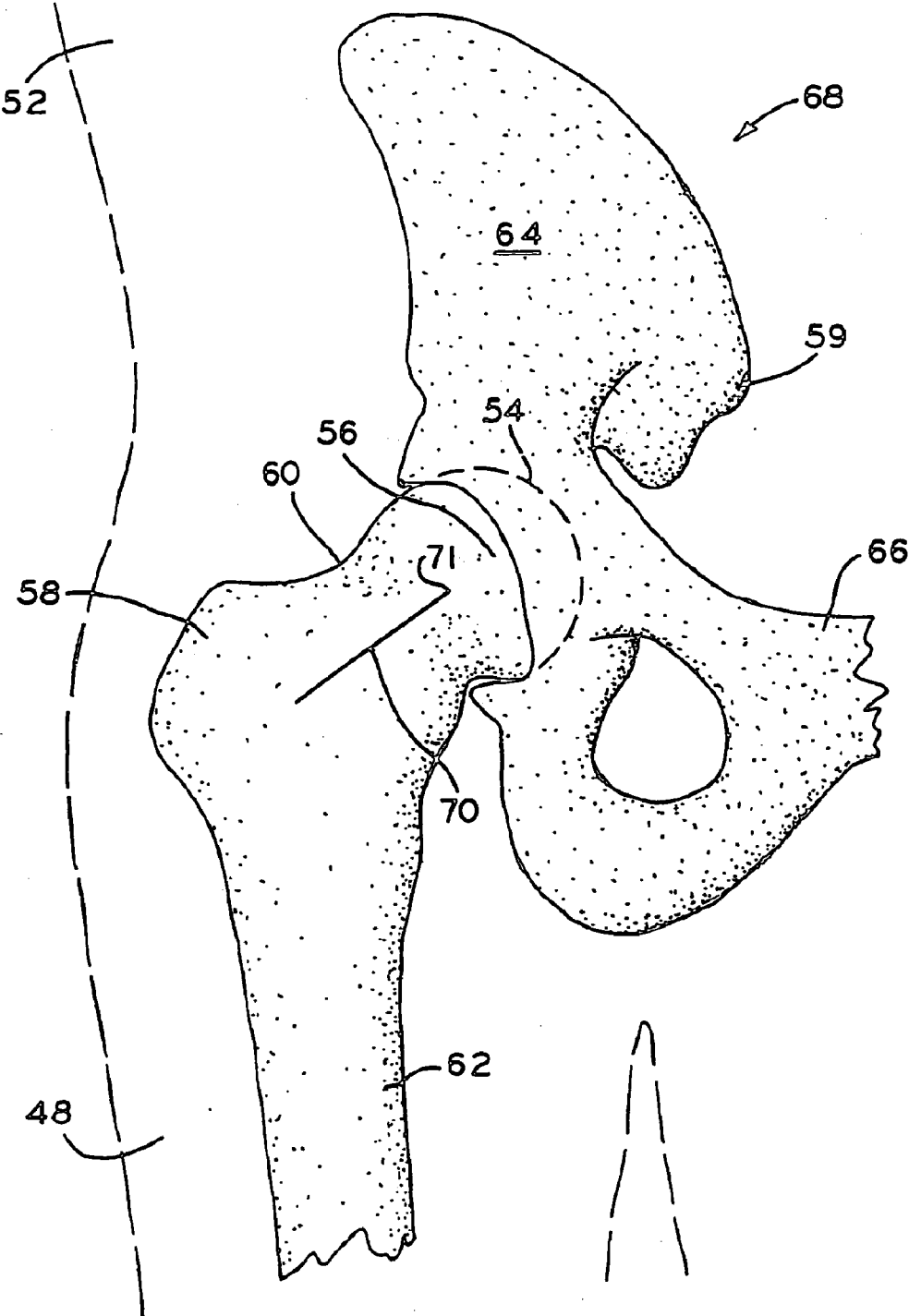

FIG. 2

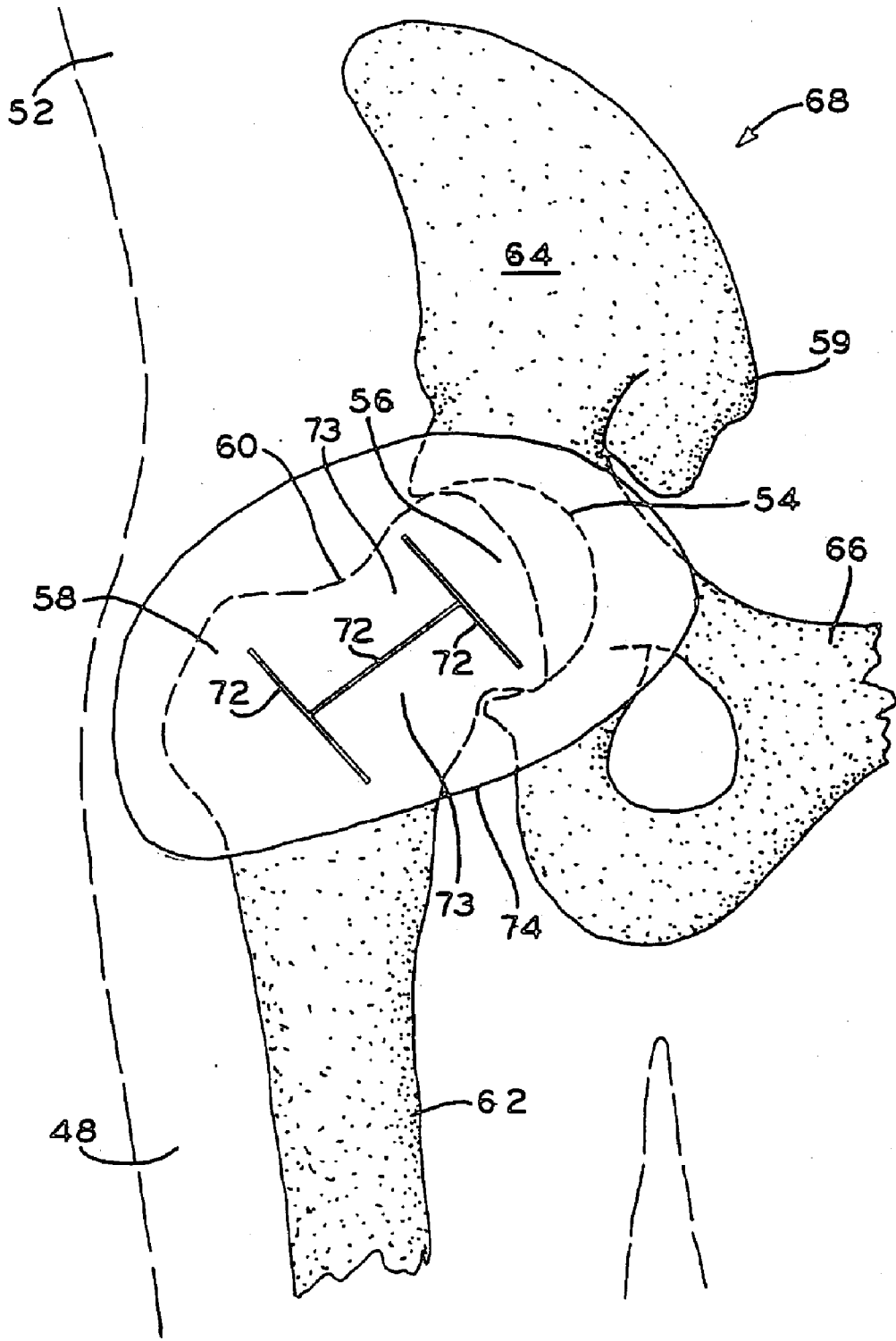

FIG. 2A

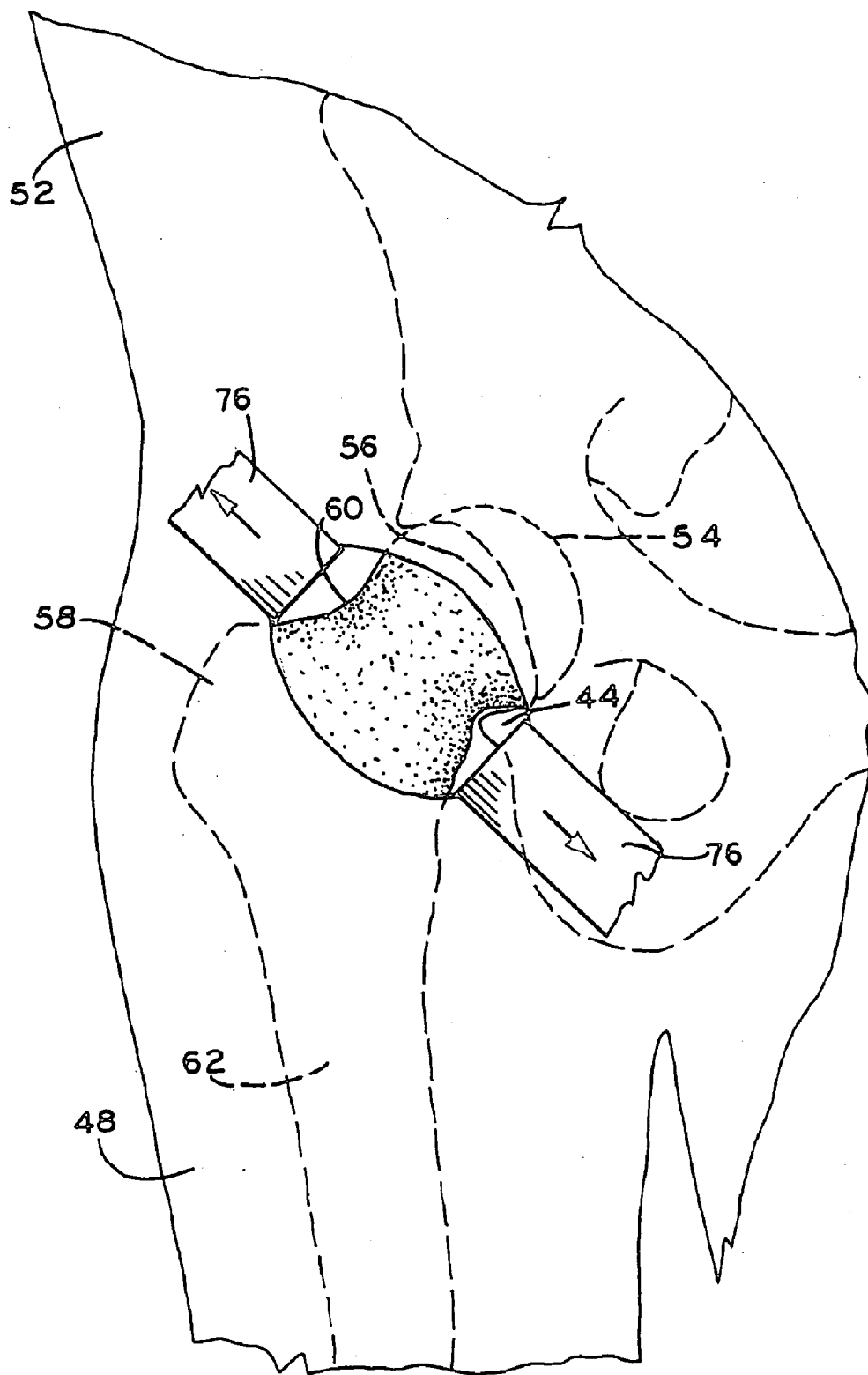

FIG. 3

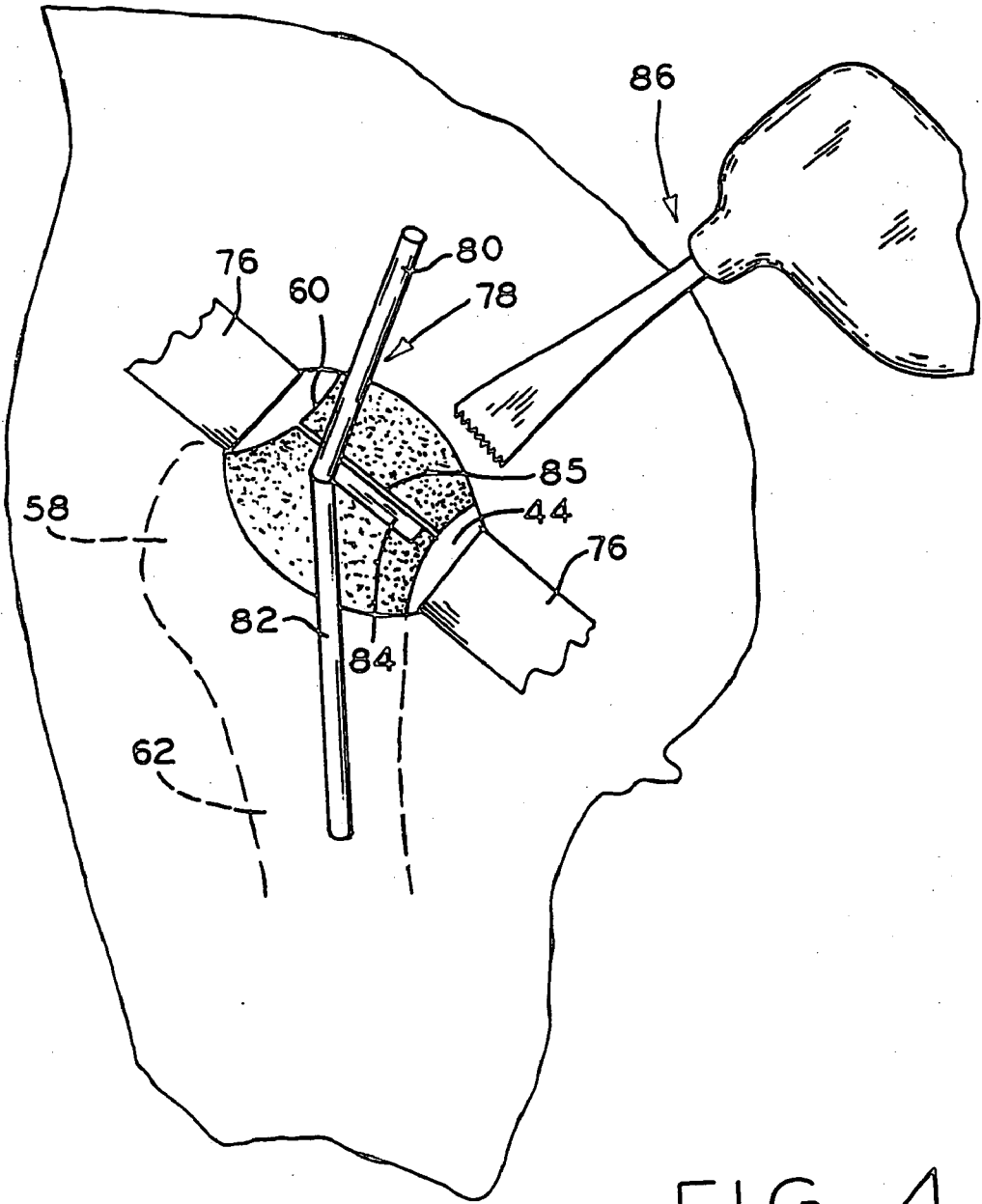

FIG. 4

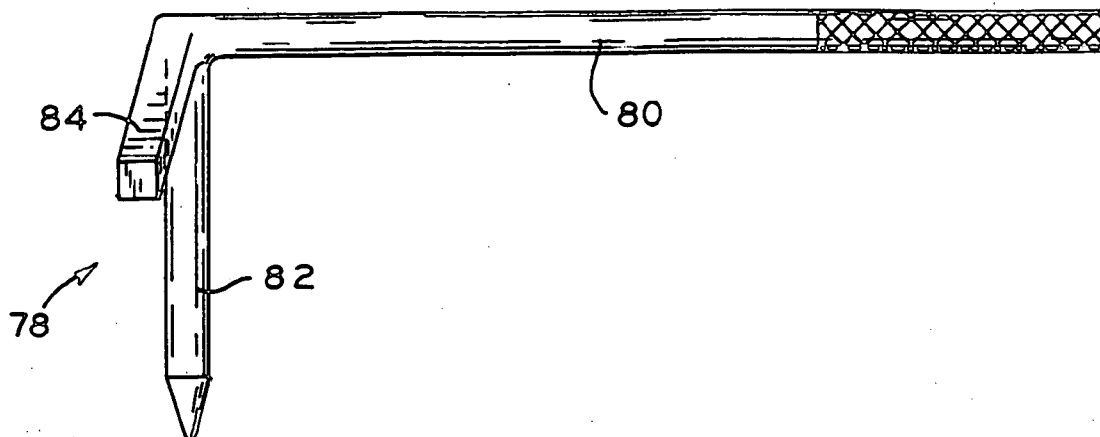

FIG. 5A

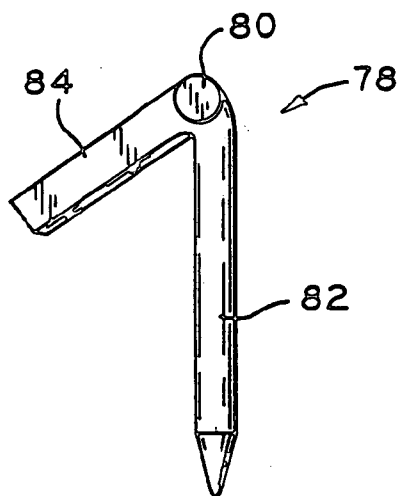

FIG. 5B

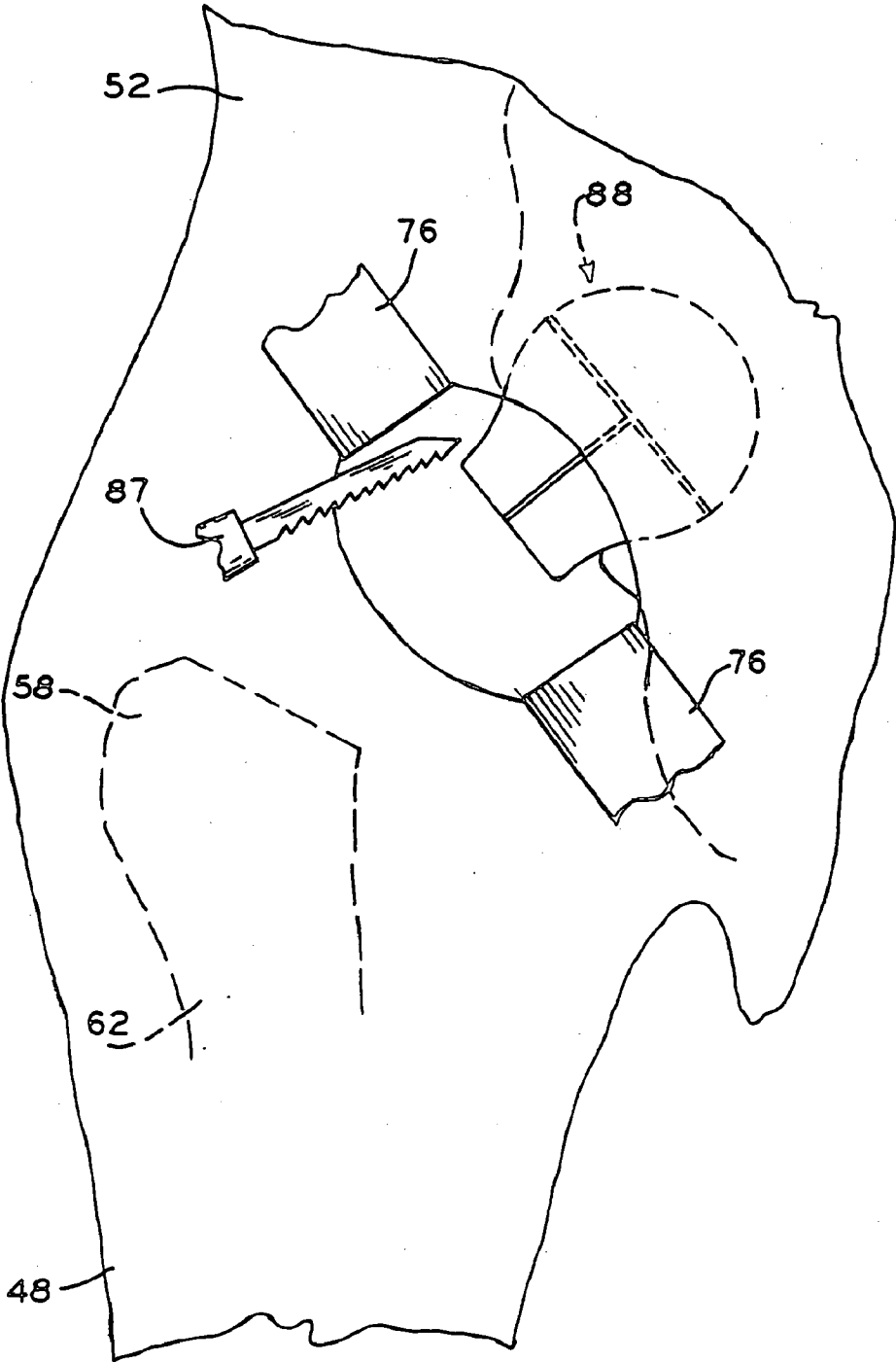

FIG. 6



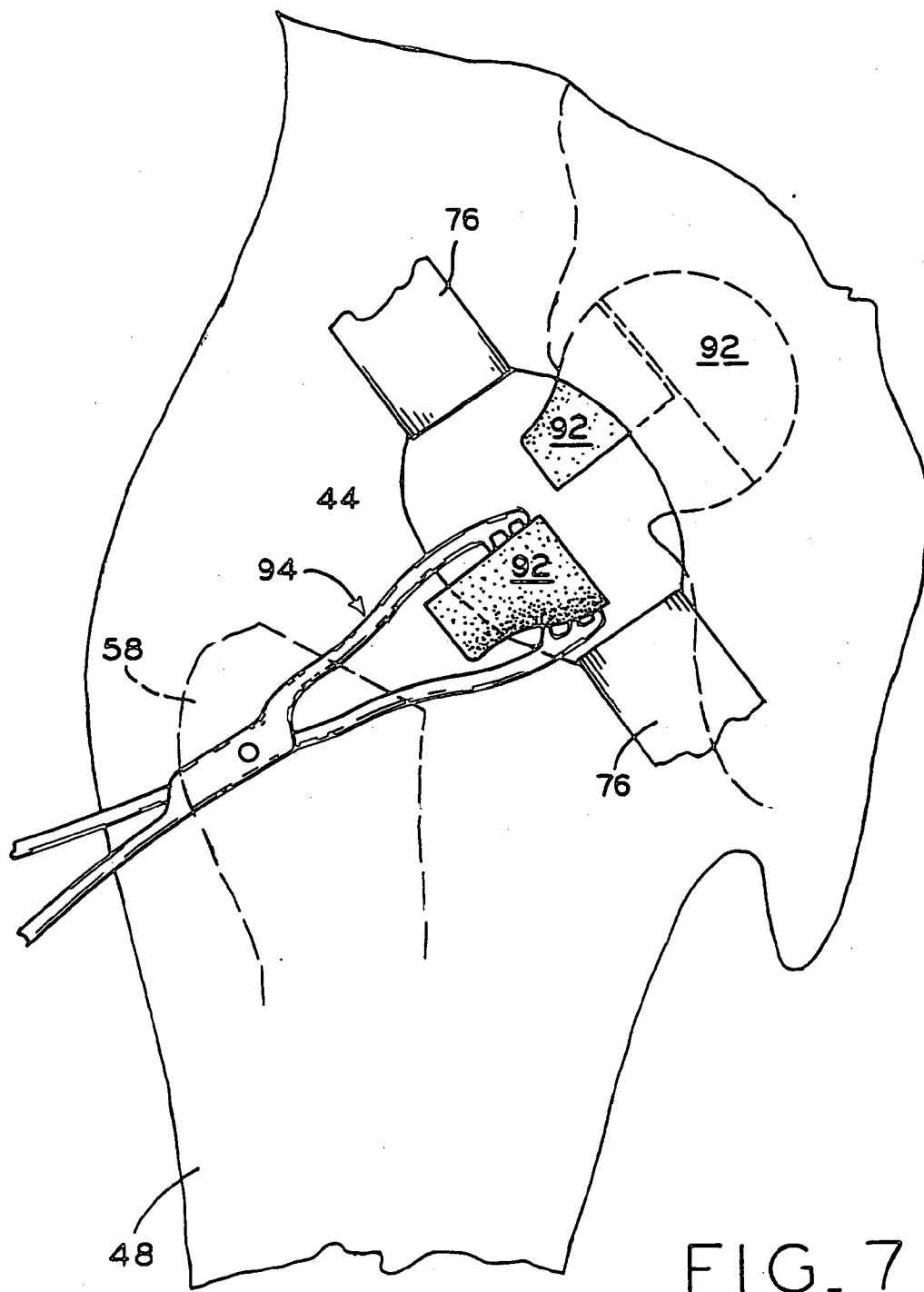
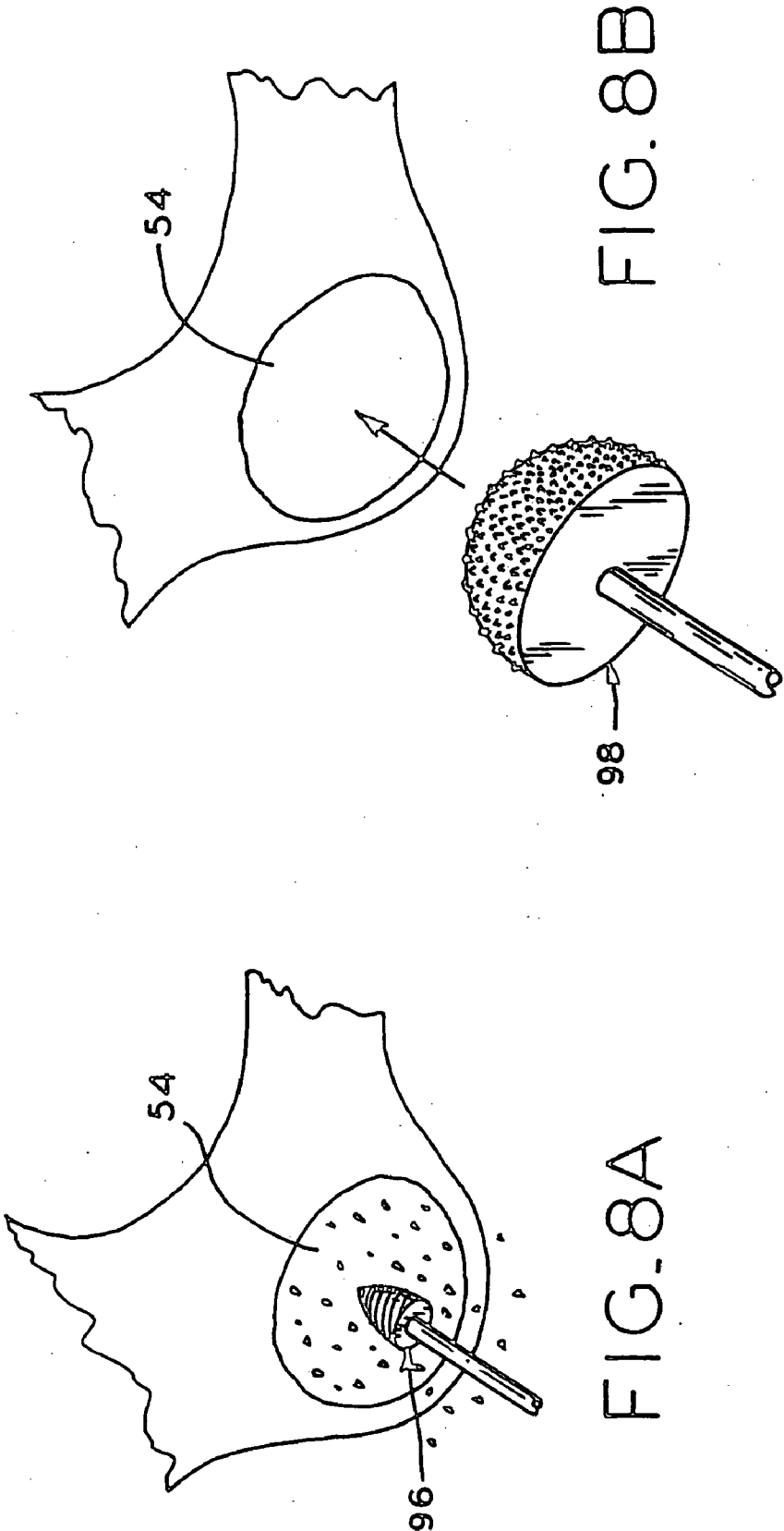

FIG. 7



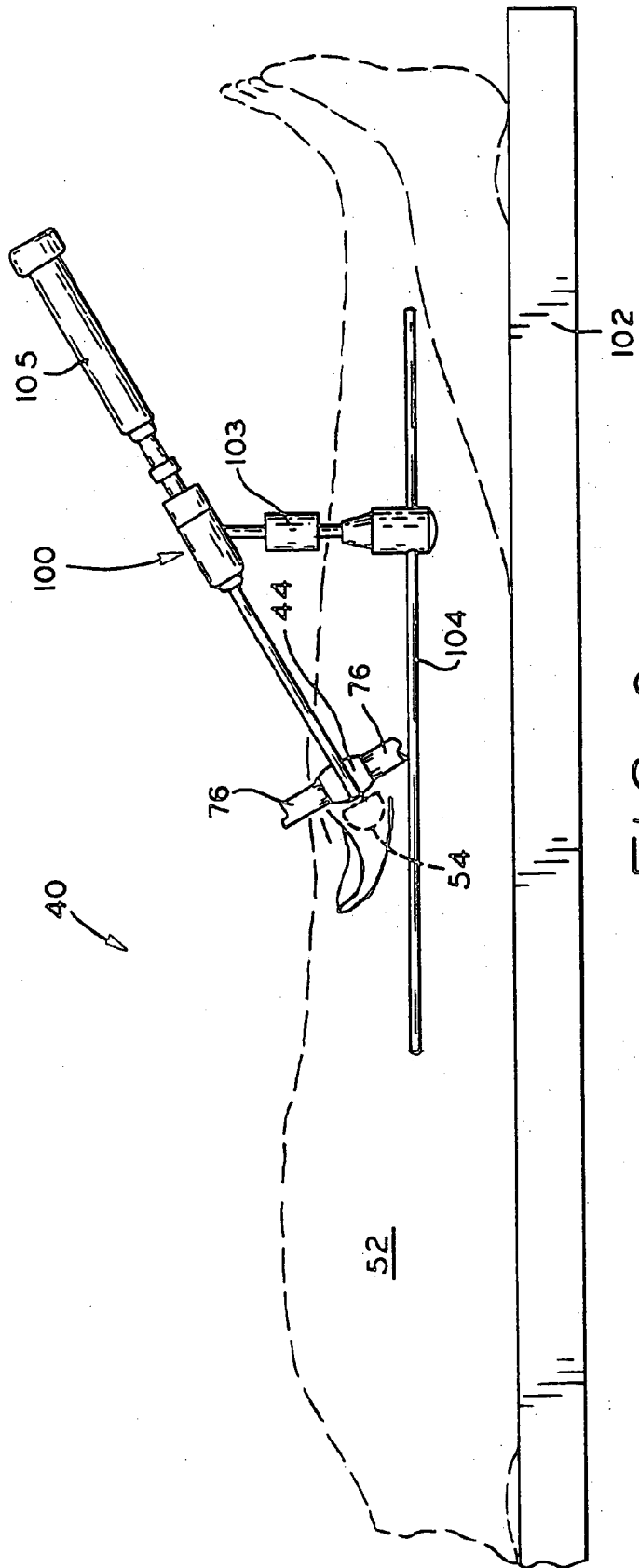
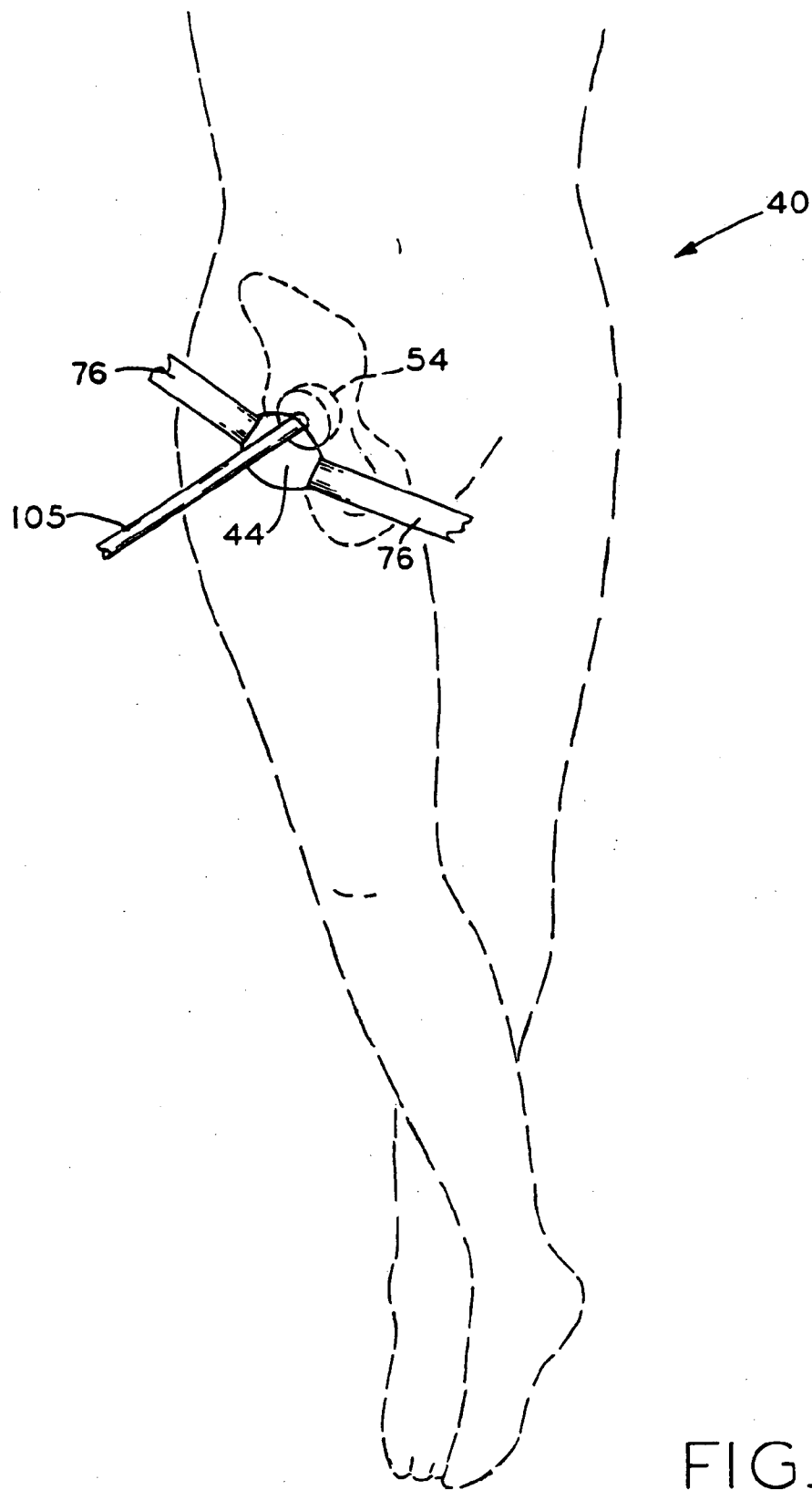

FIG. 9



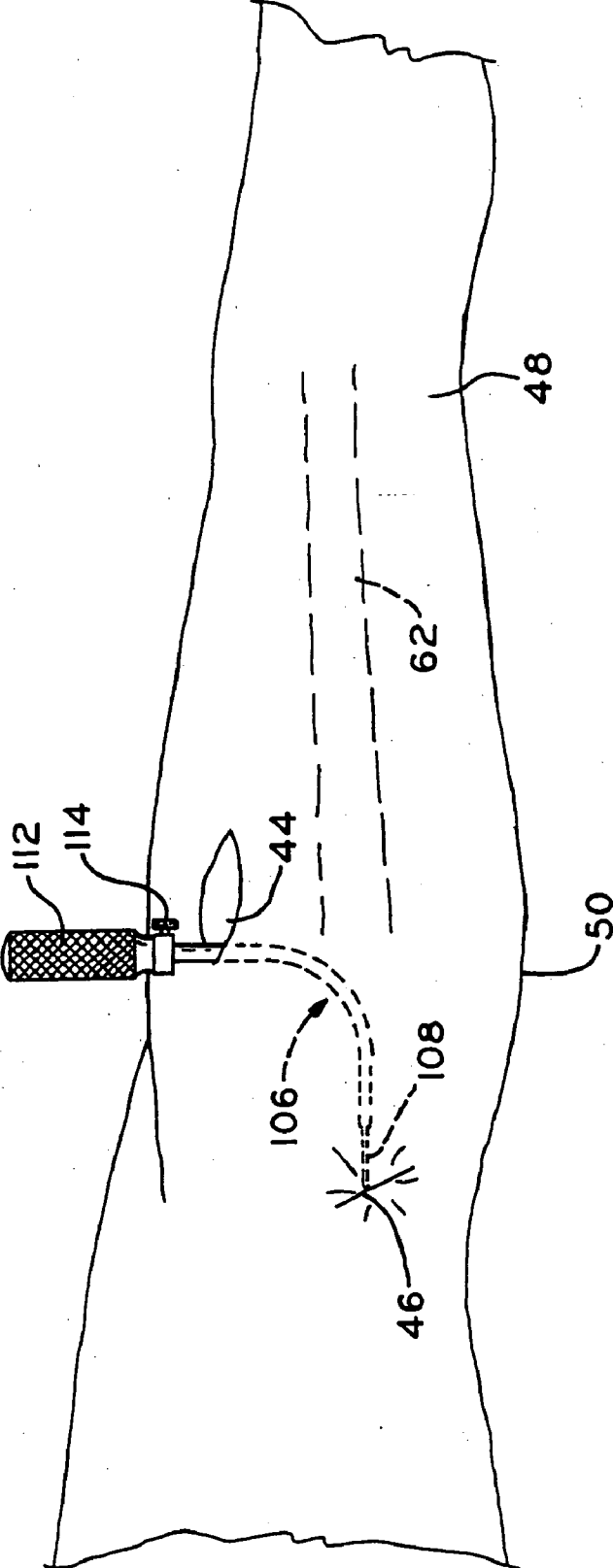

FIG. 11

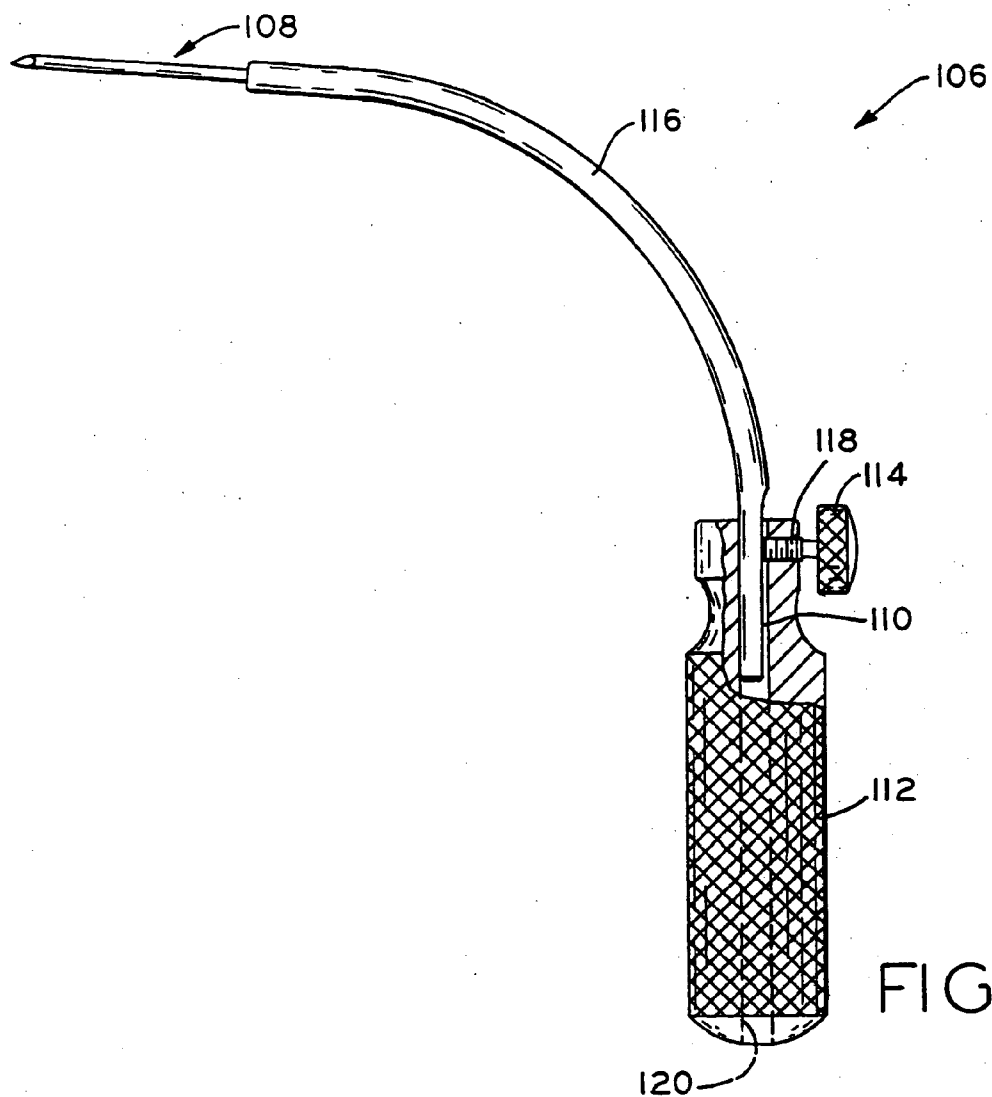

FIG. 12

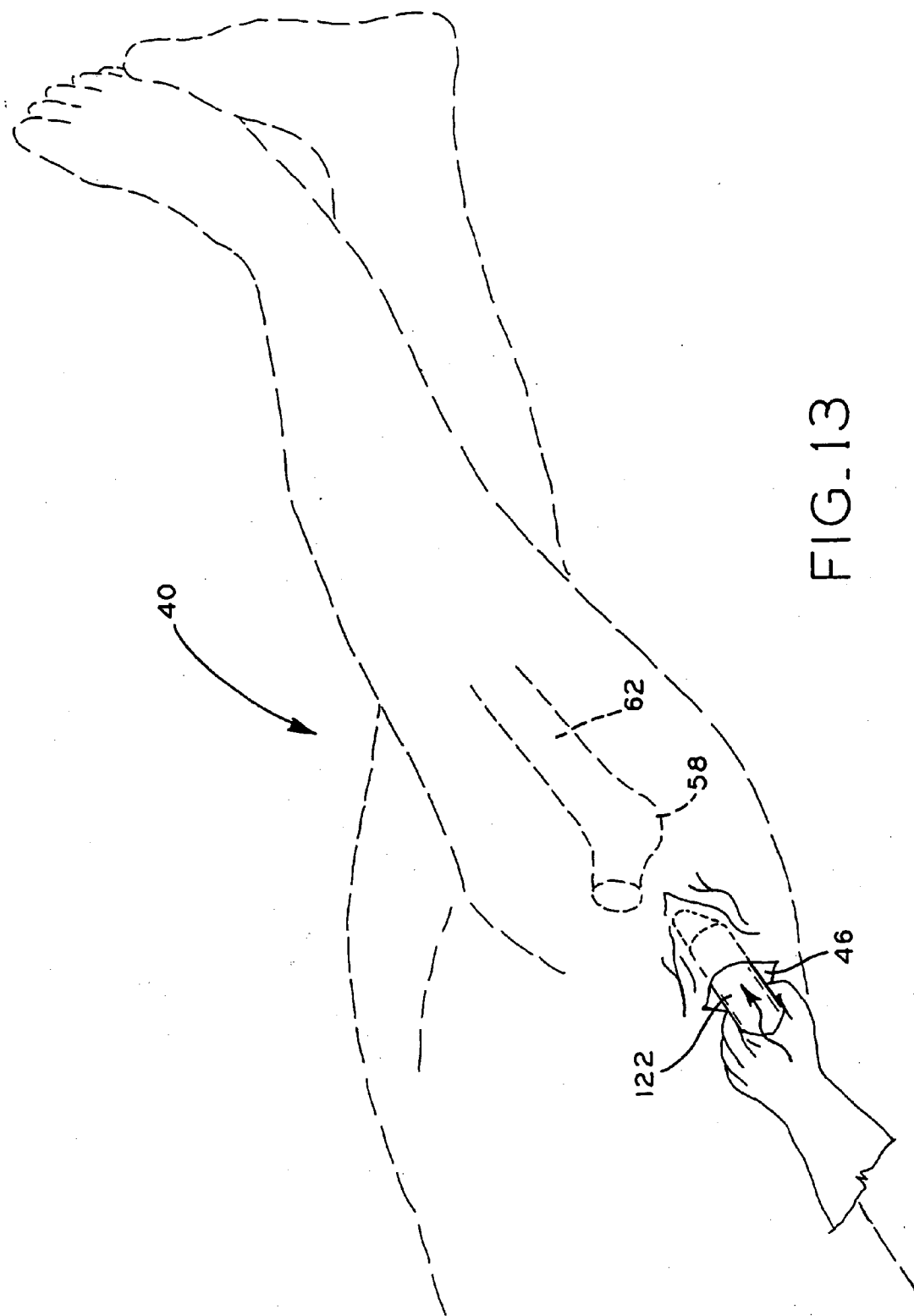

FIG. 13

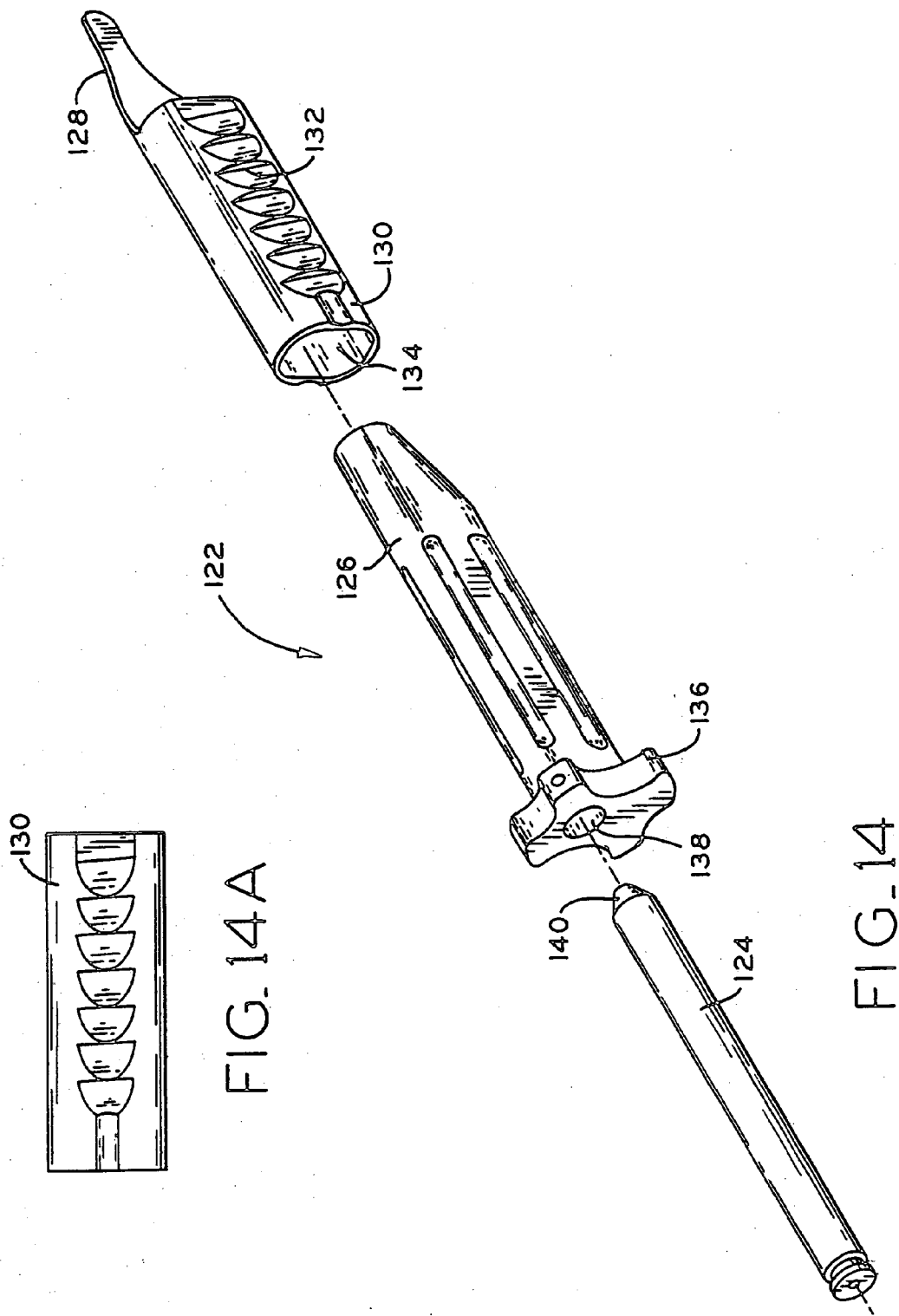
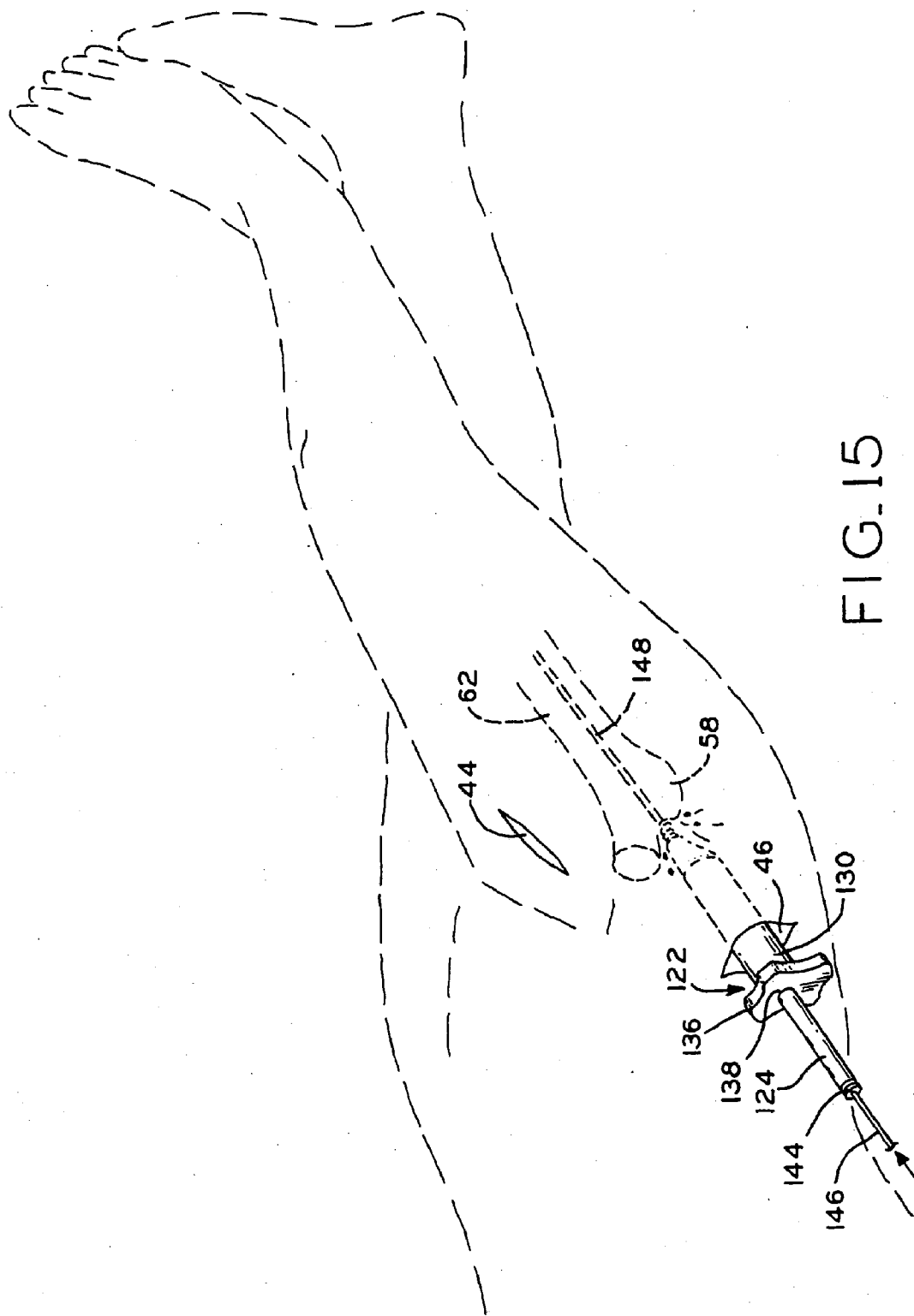

FIG. 14A

FIG. 14





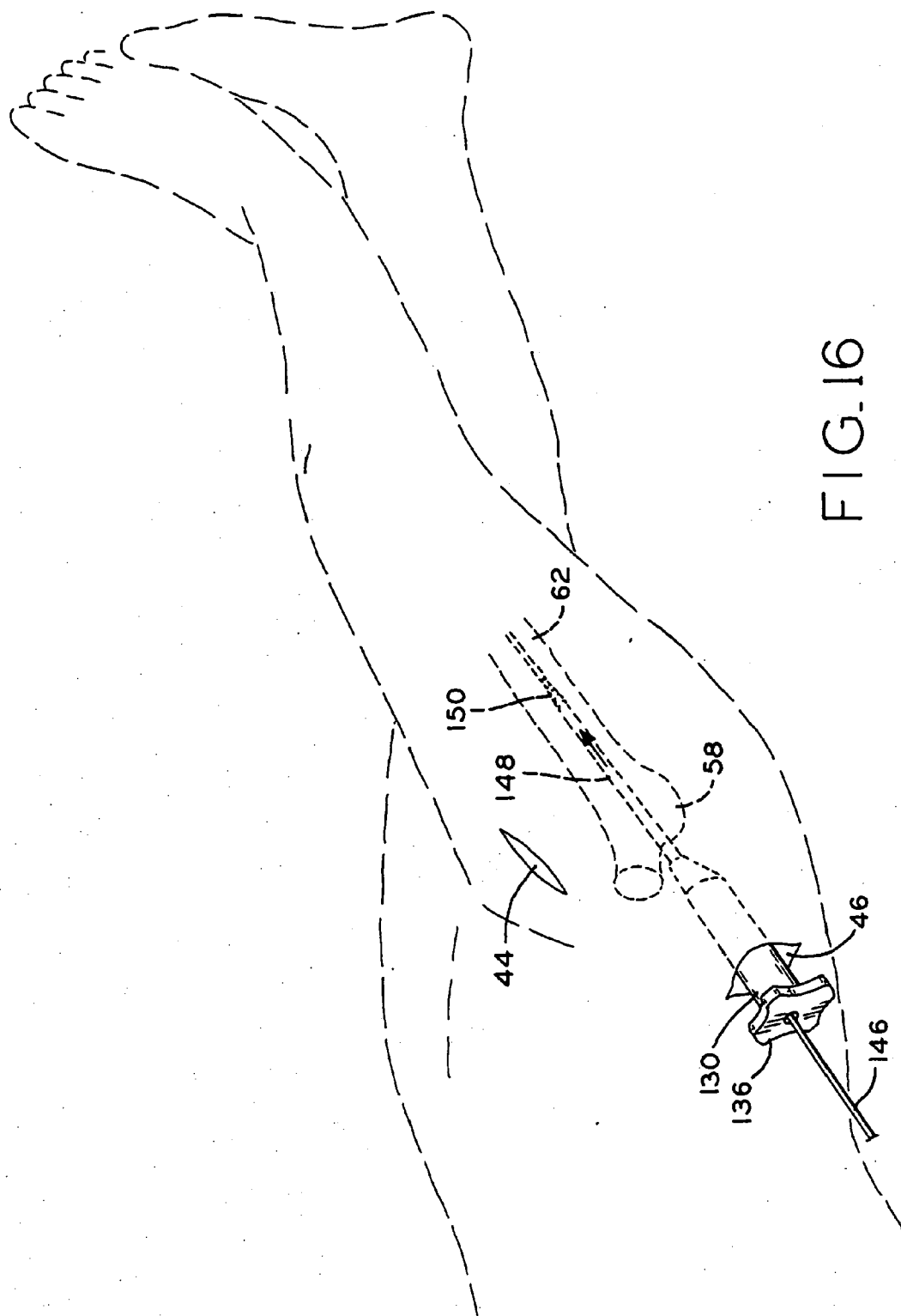
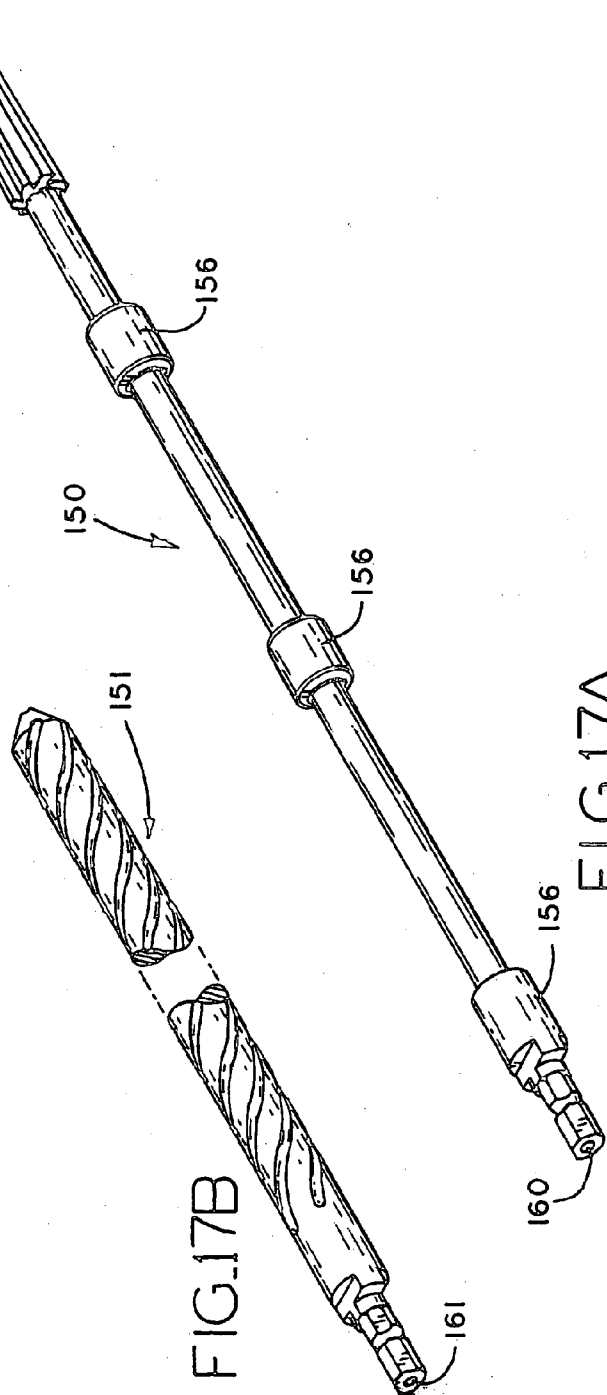
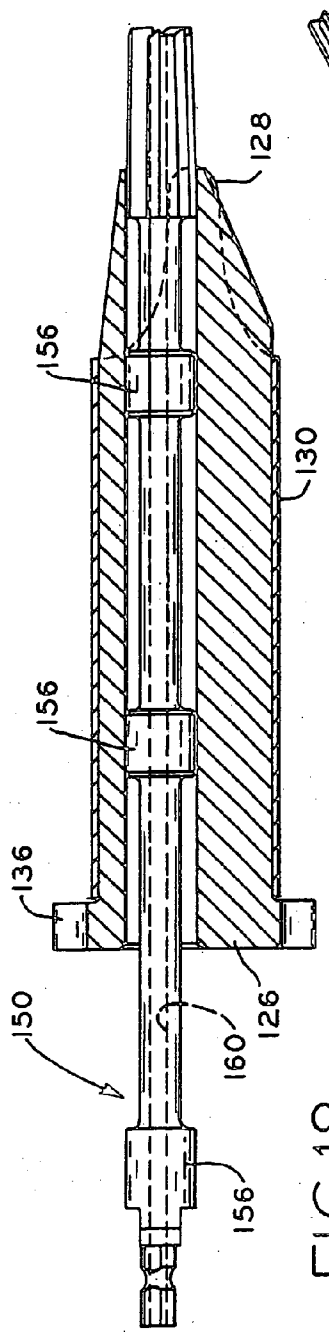

FIG. 16



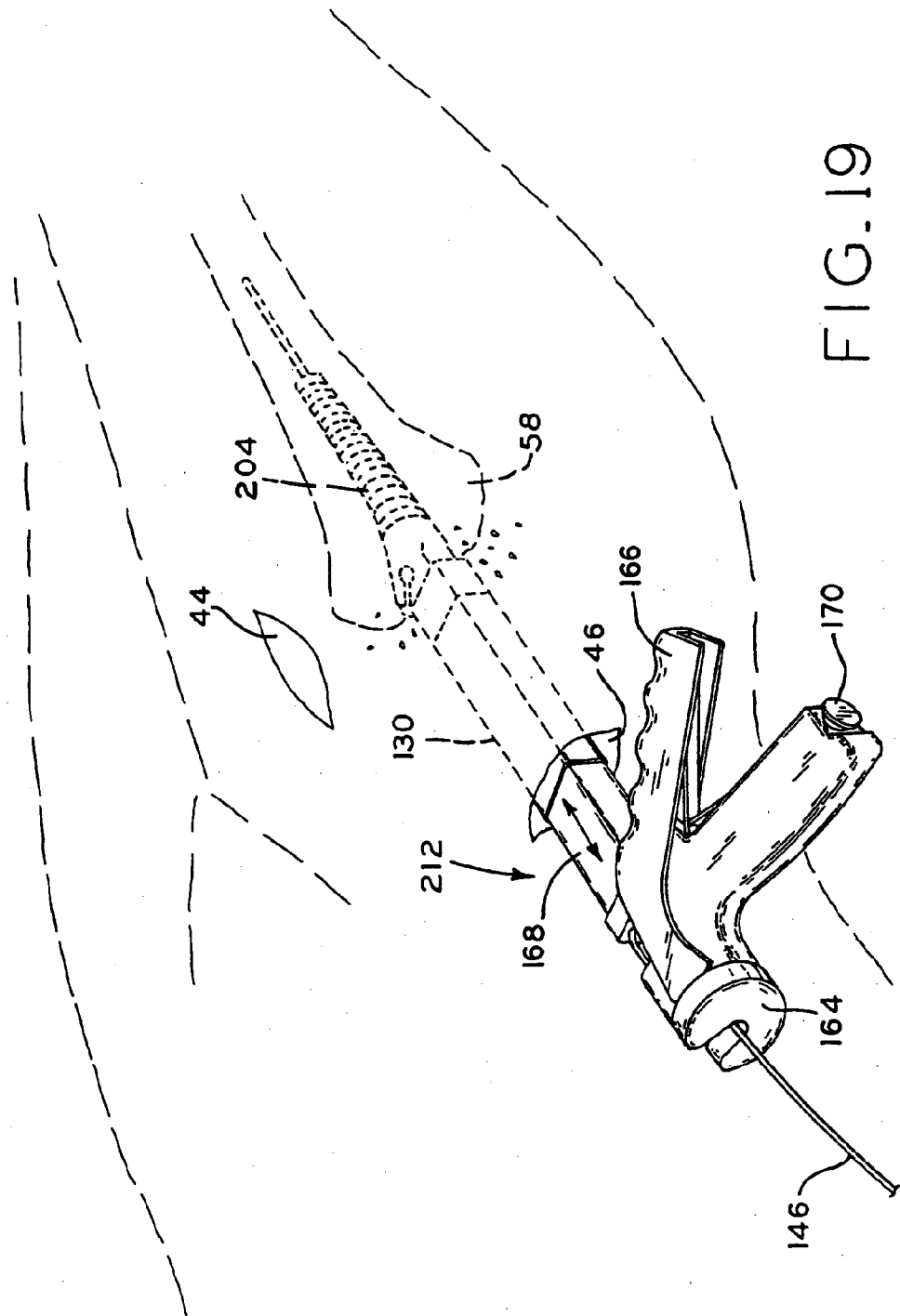

FIG. 19

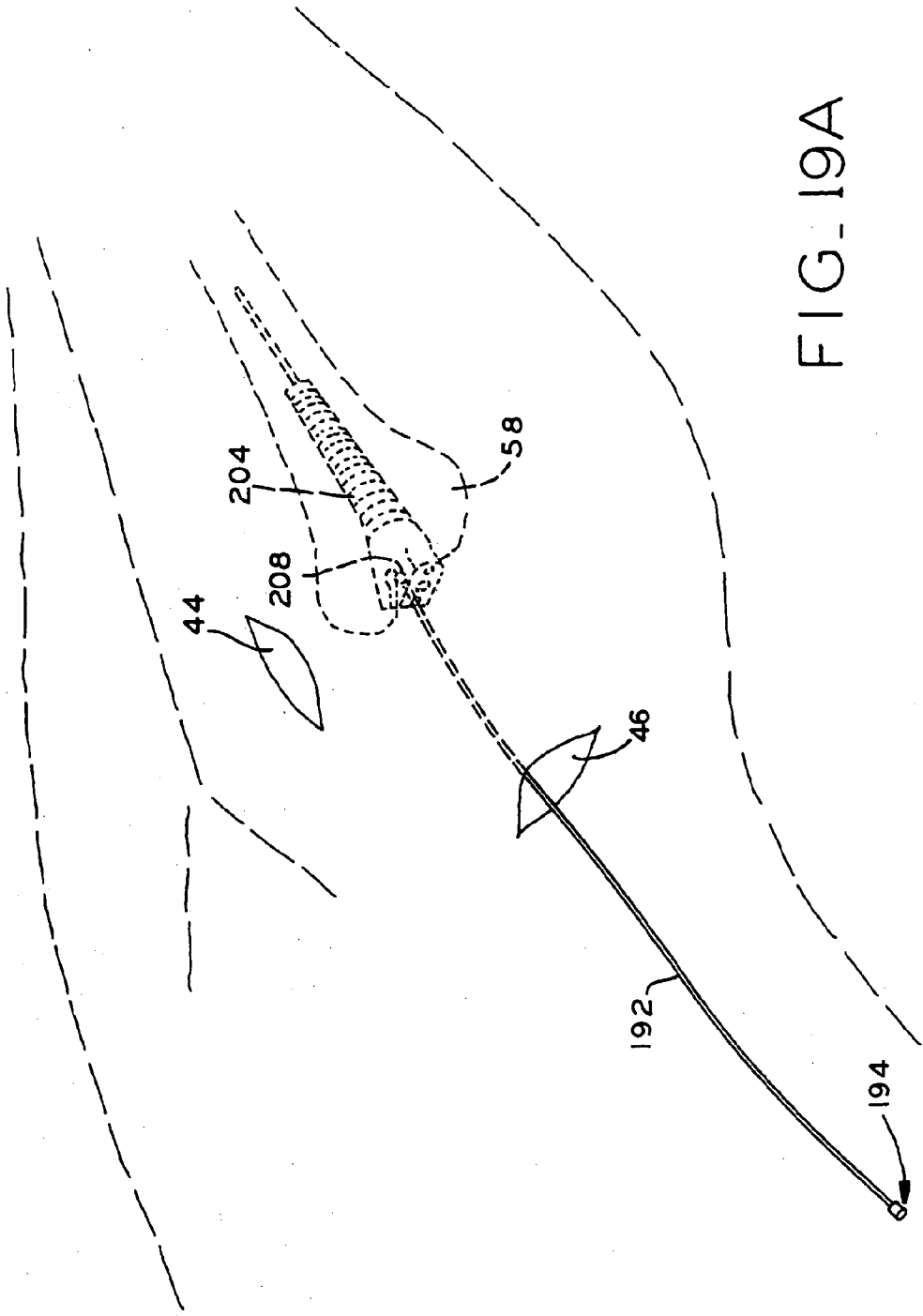

FIG. 19A

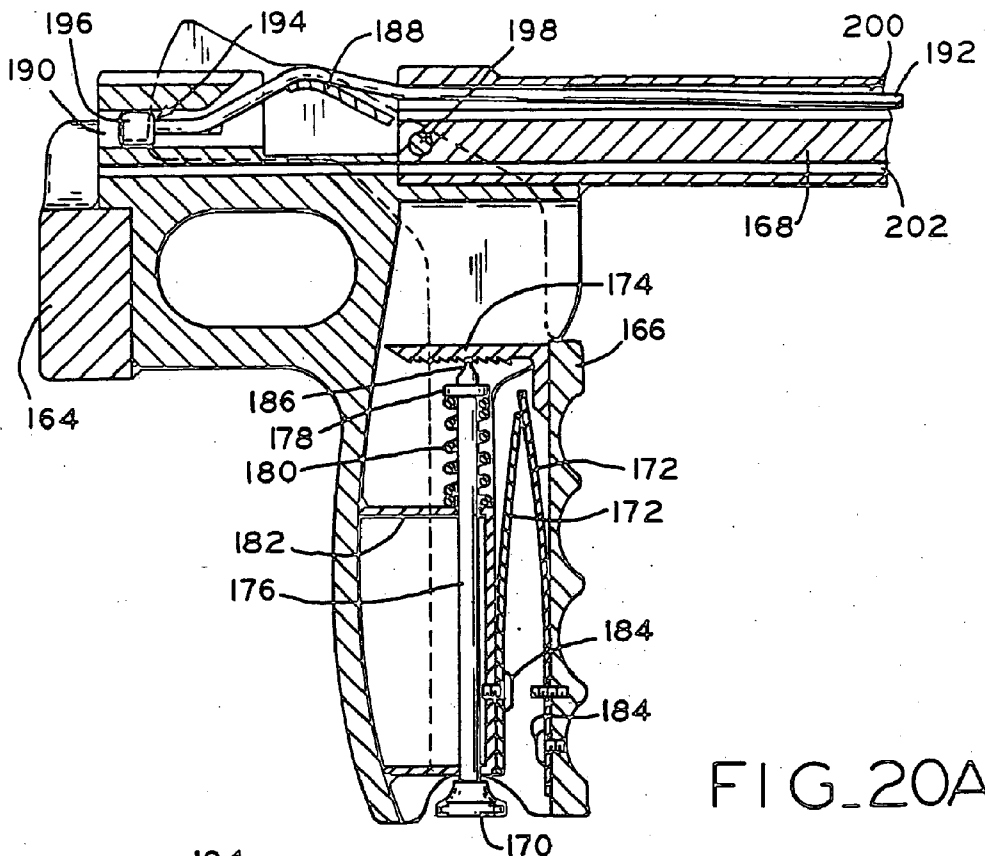

FIG. 20A

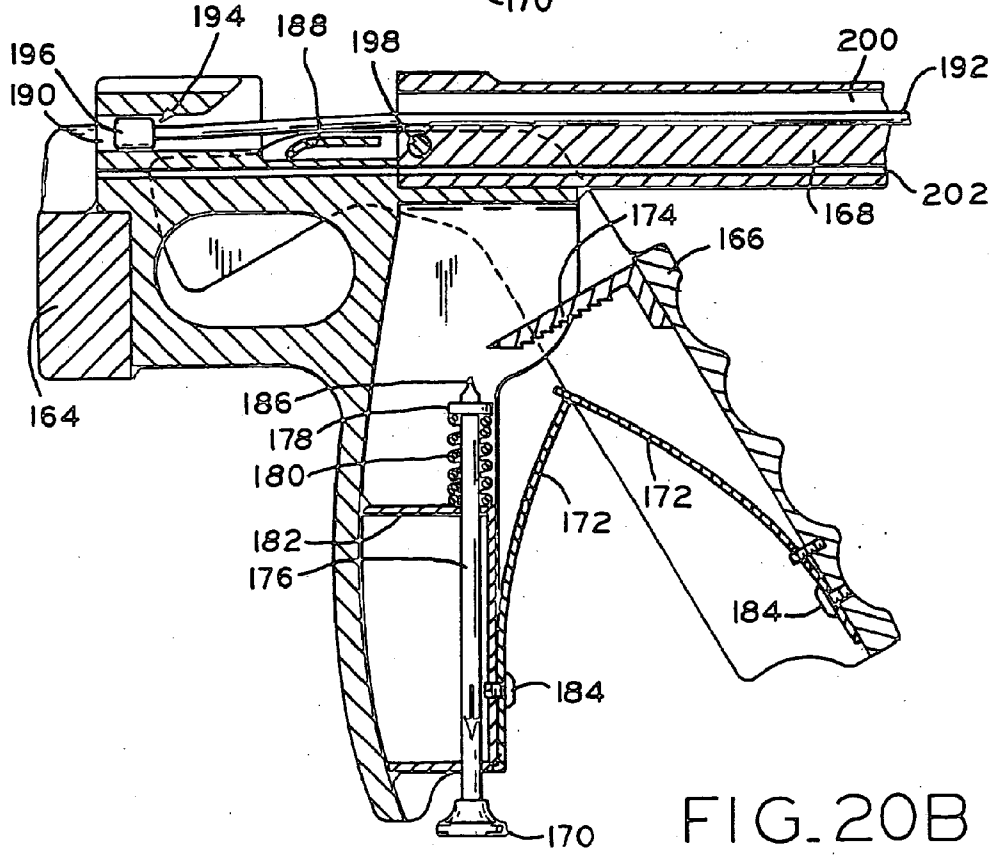

FIG. 20B

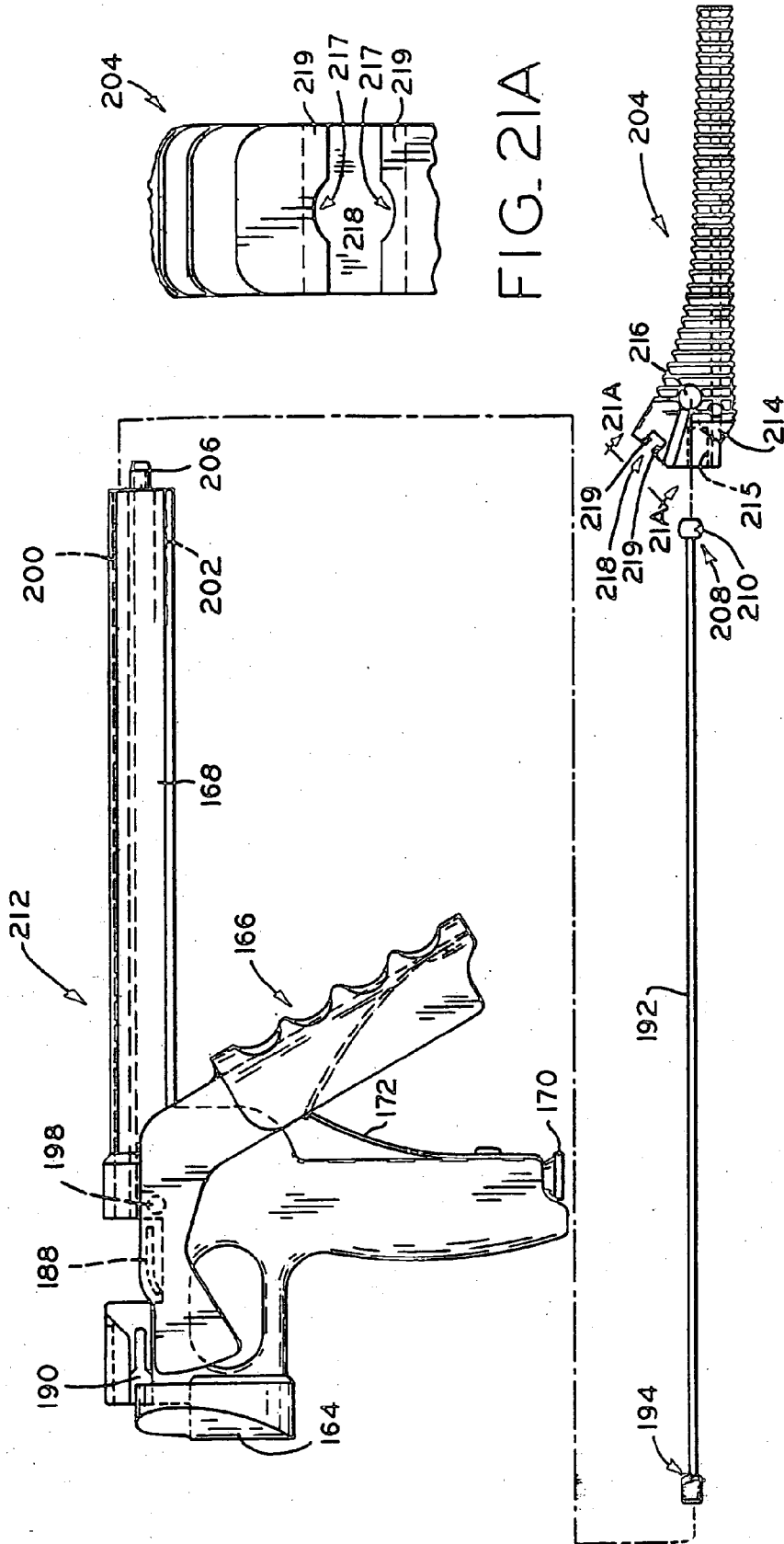

FIG. 21A

FIG. 21

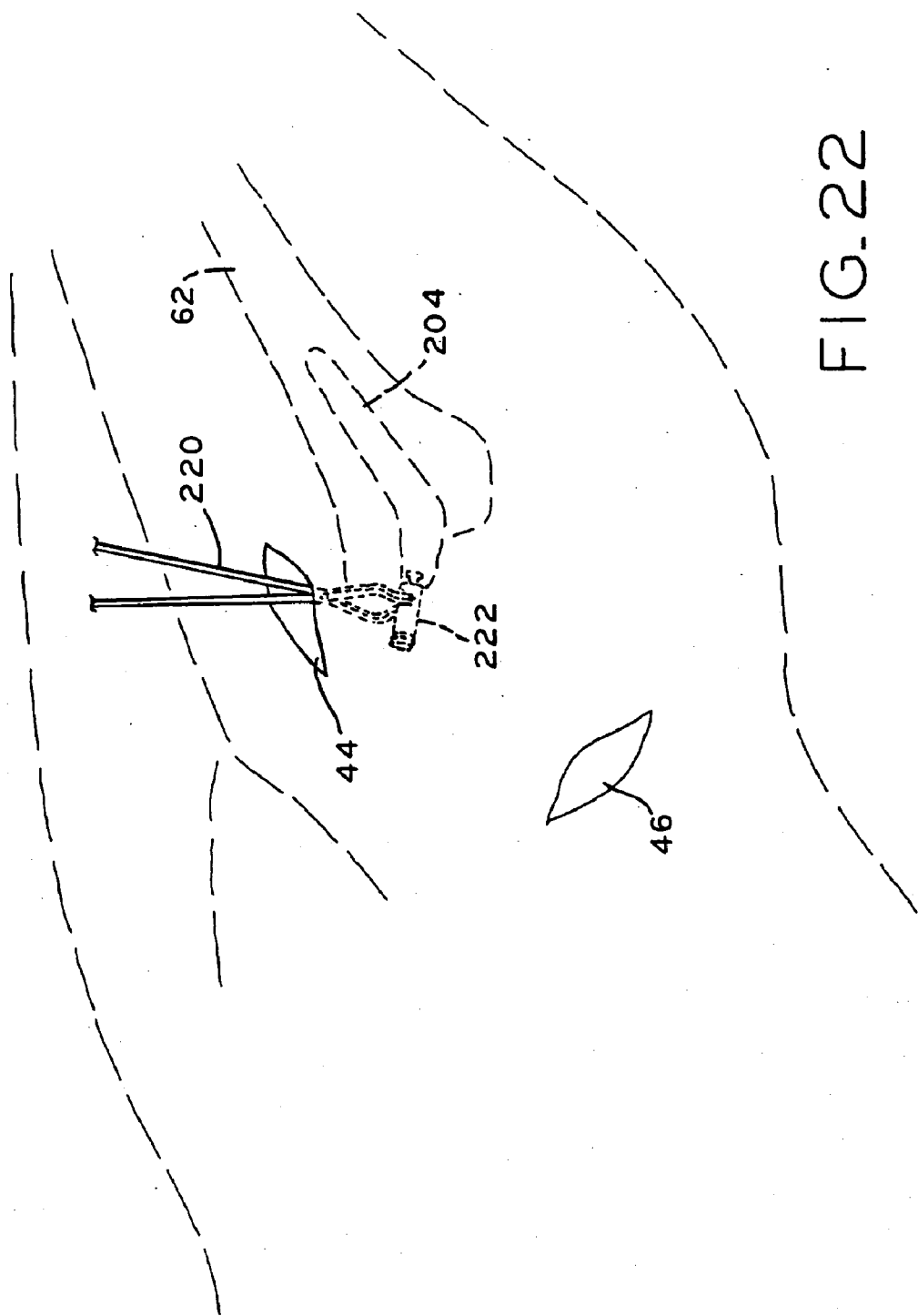

FIG. 22





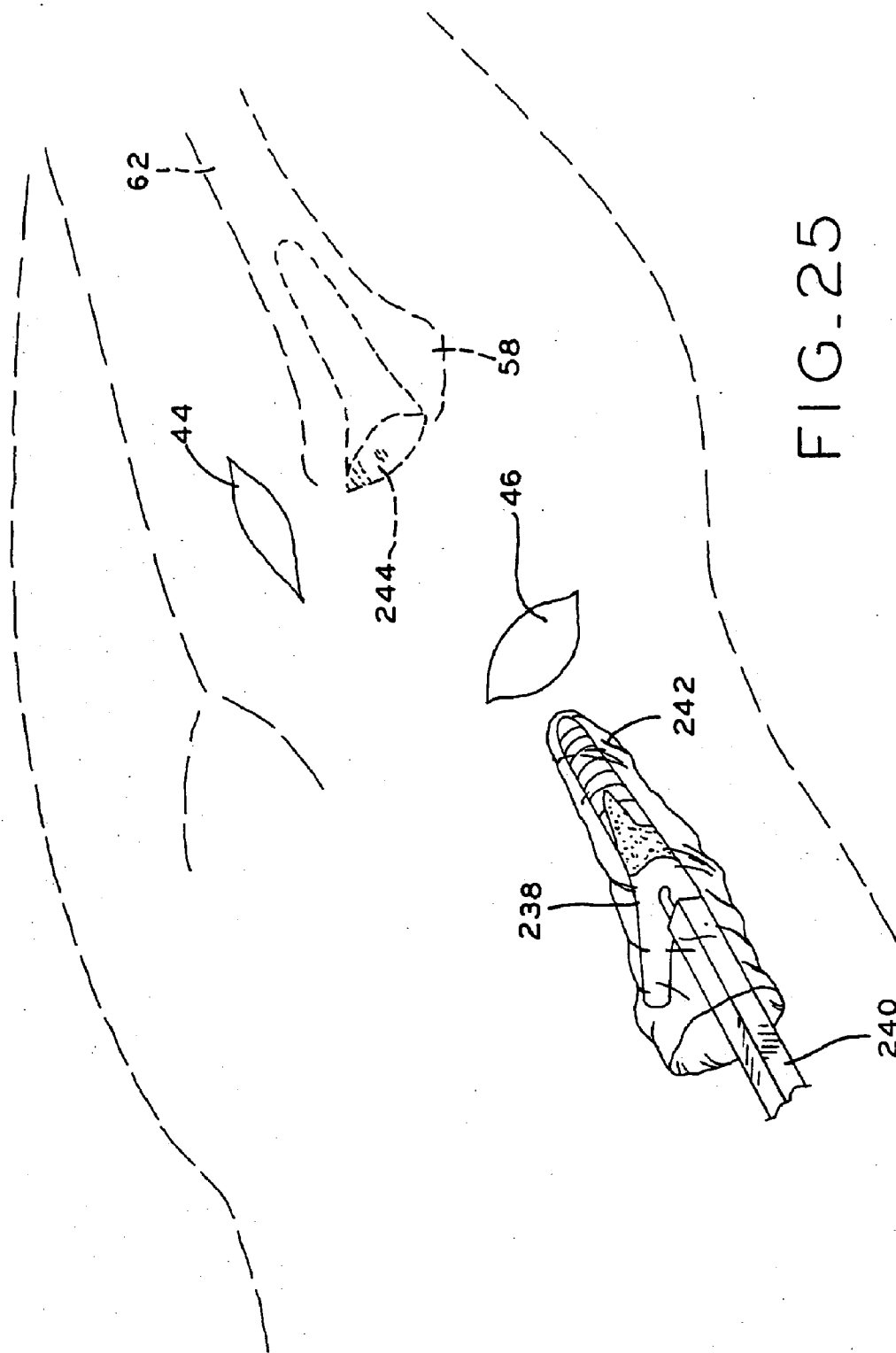

FIG-25

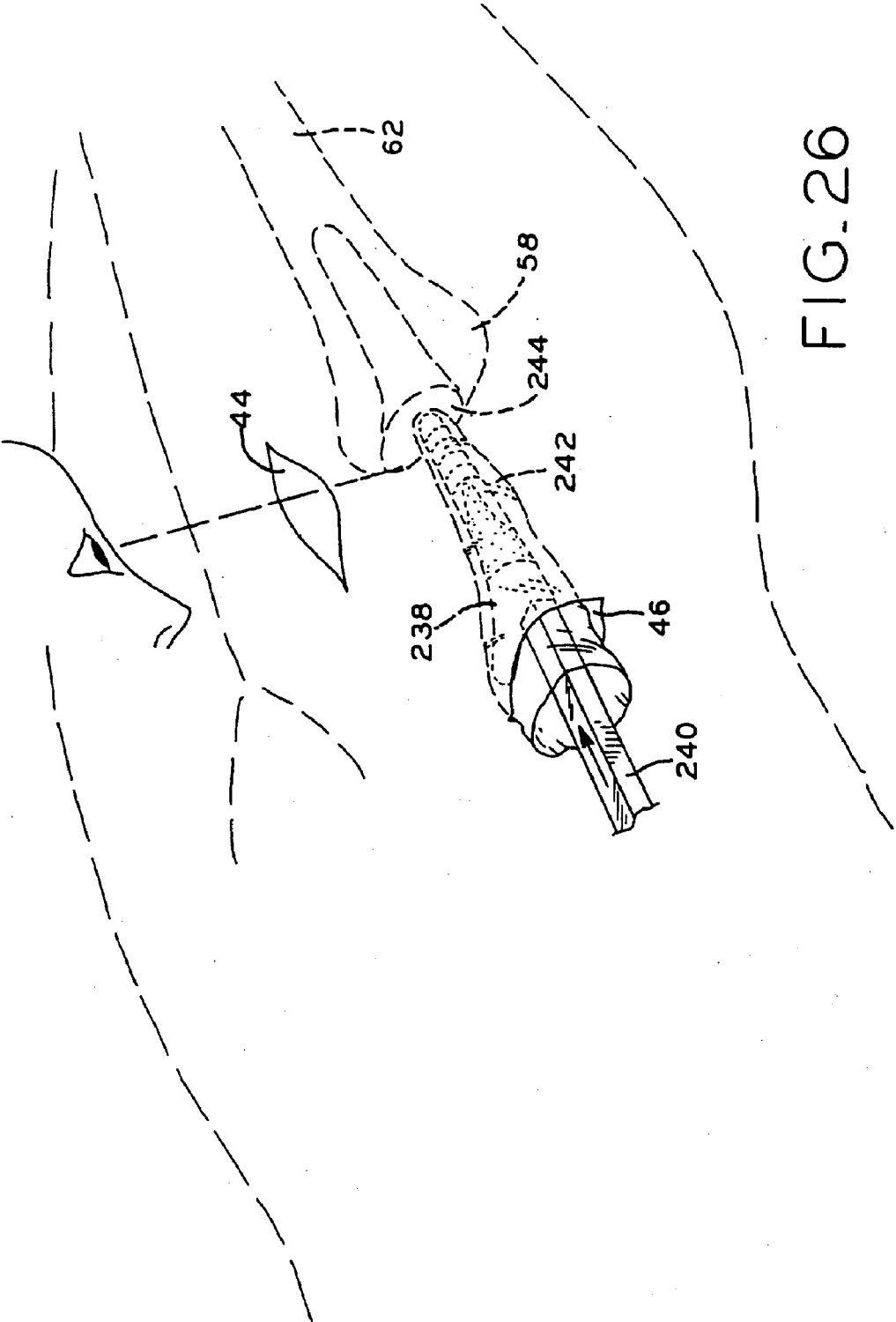

FIG. 26

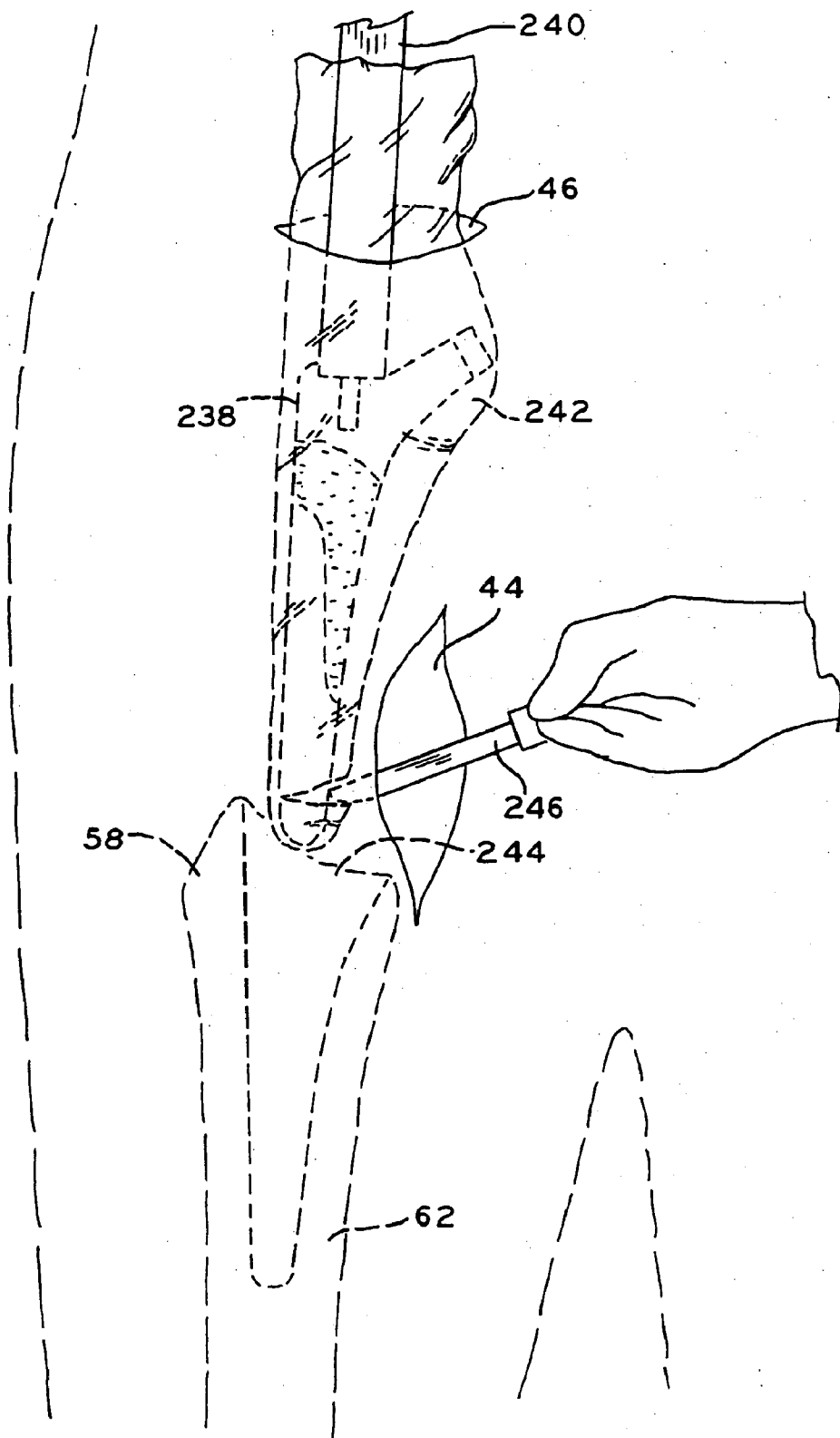

FIG. 27

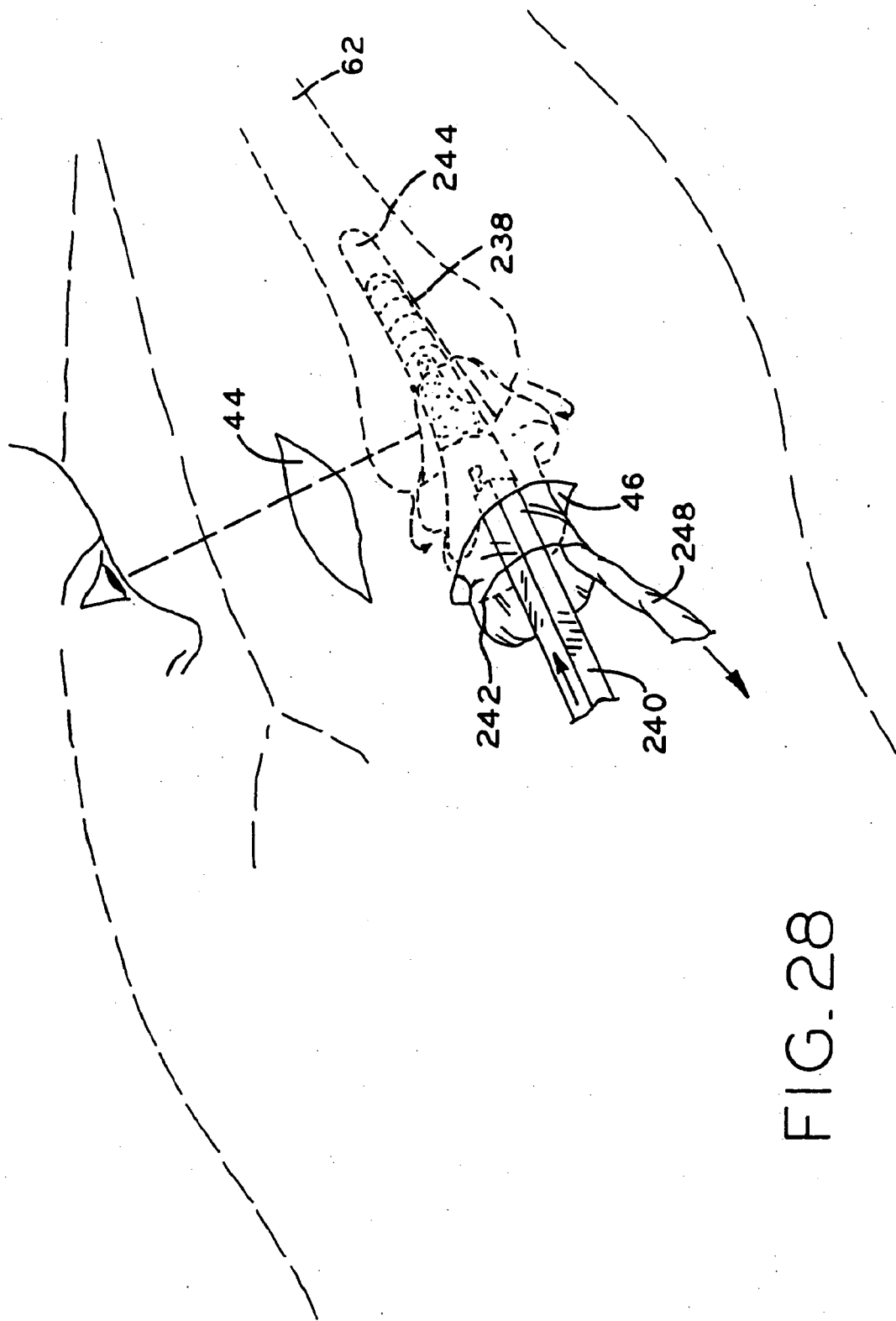

FIG. 28

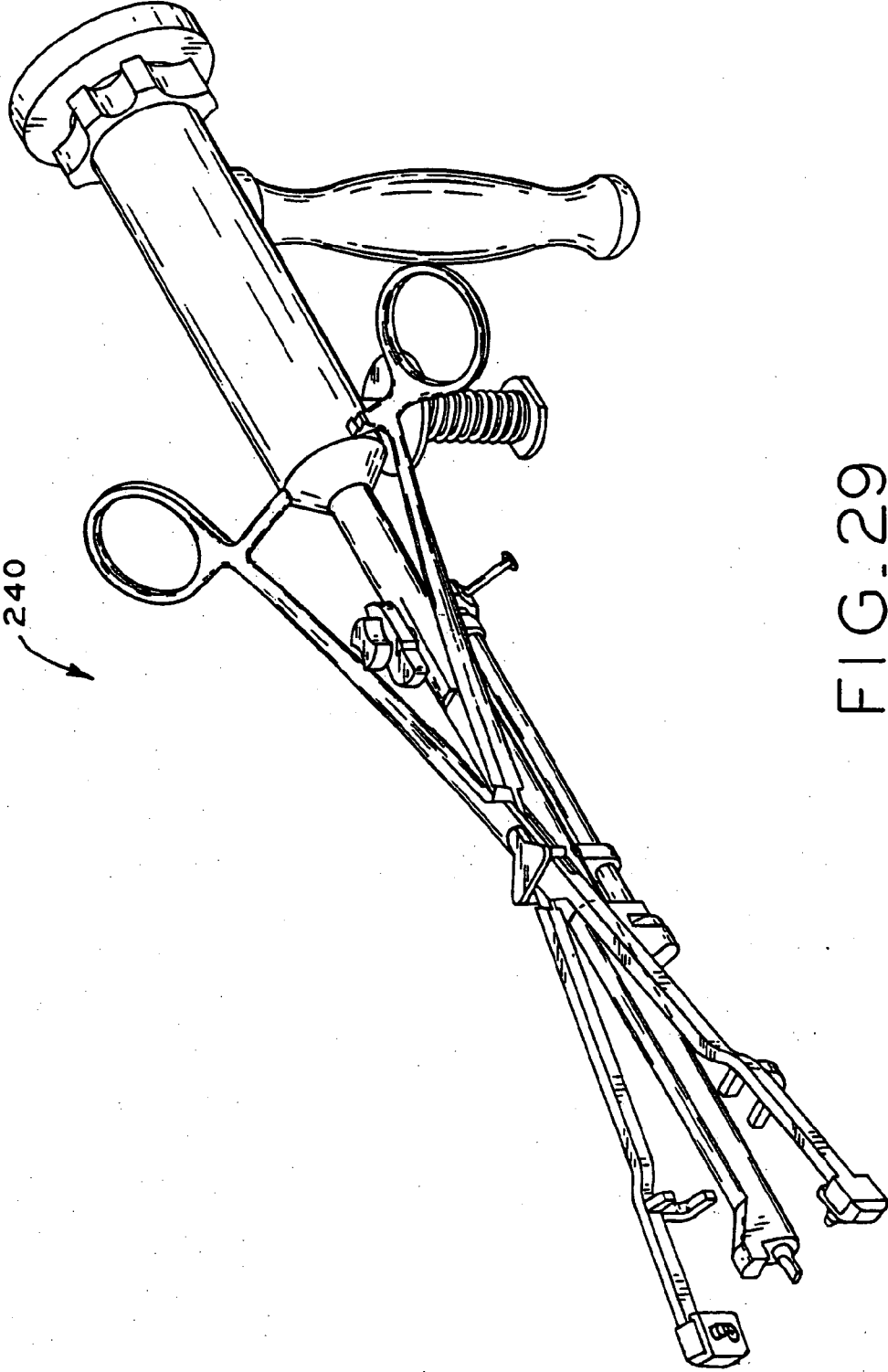

FIG. 29

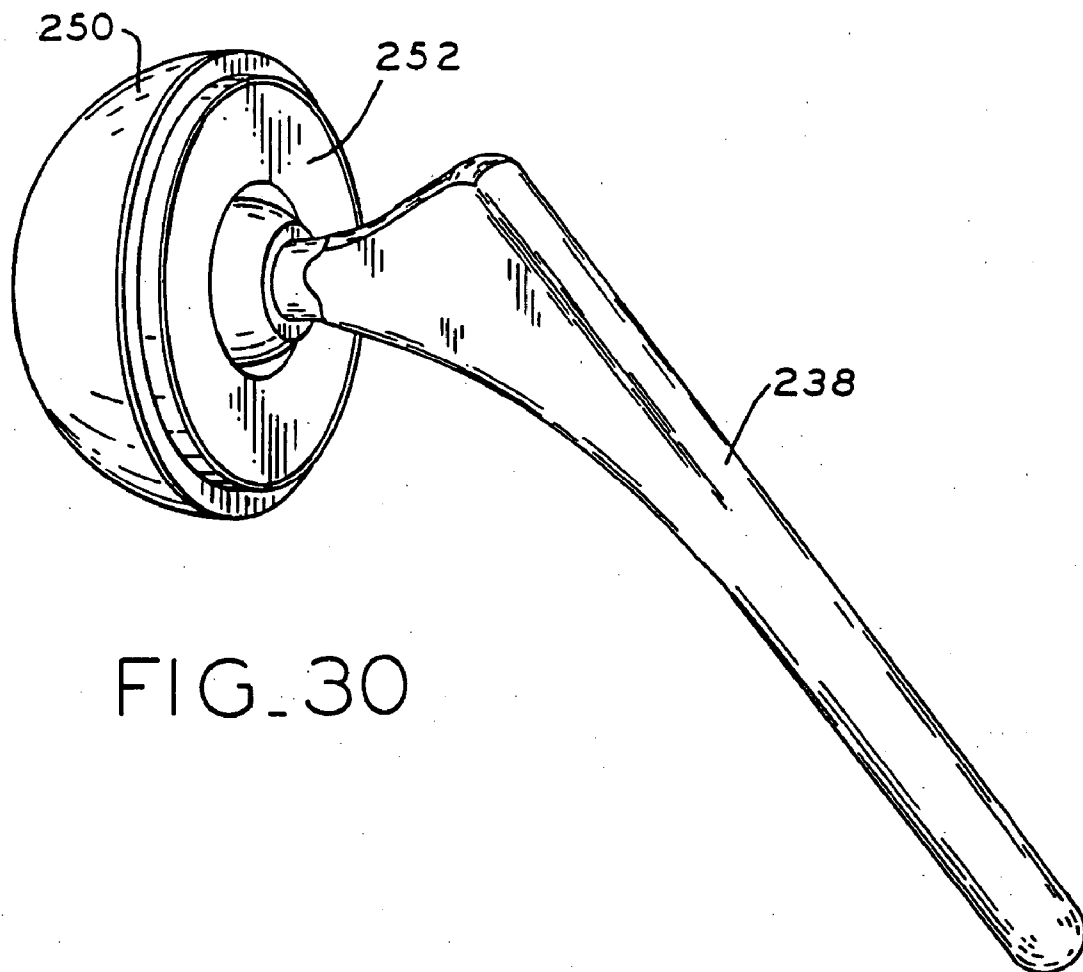
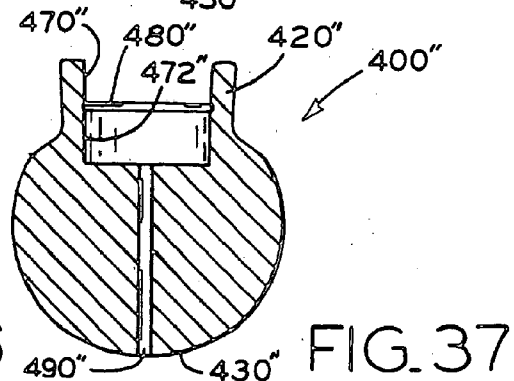
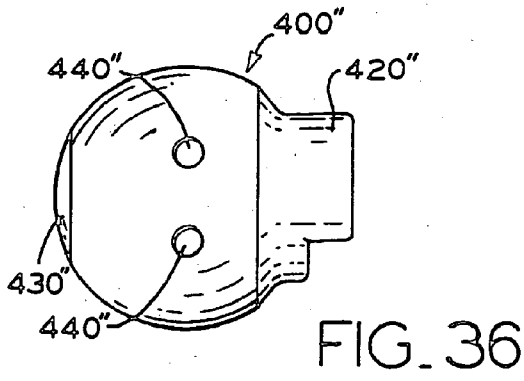
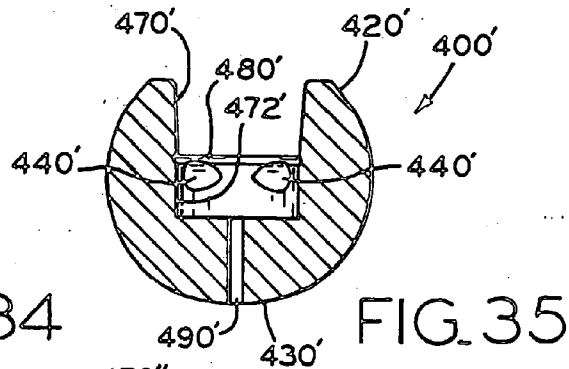
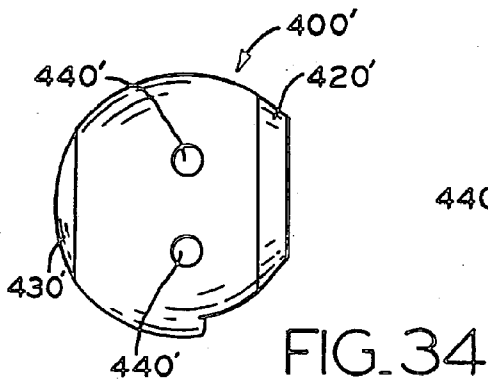
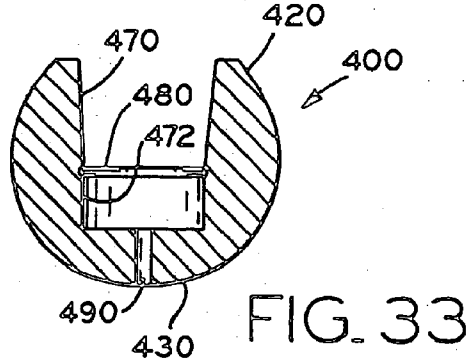
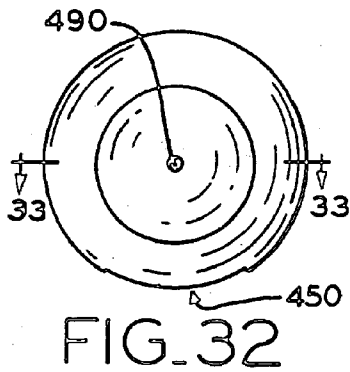
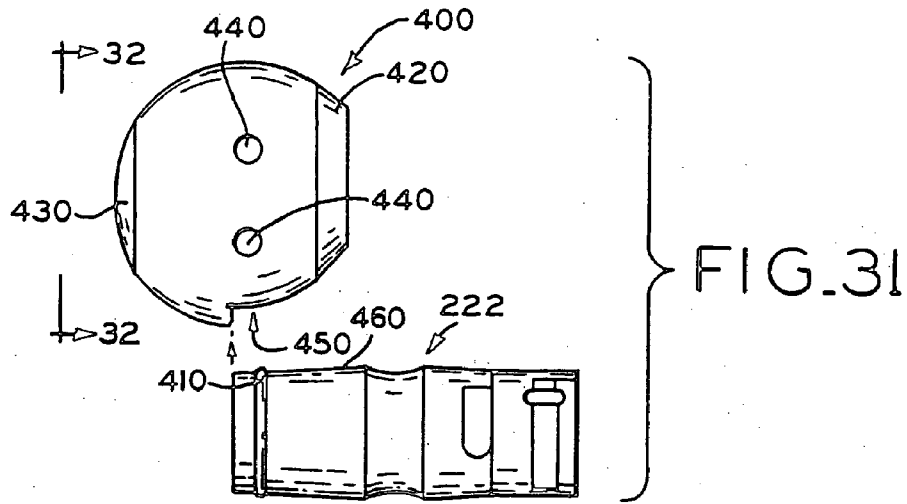

FIG. 30





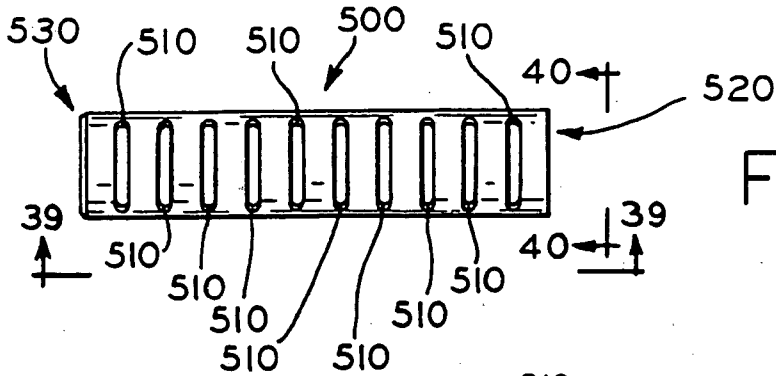

FIG. 38

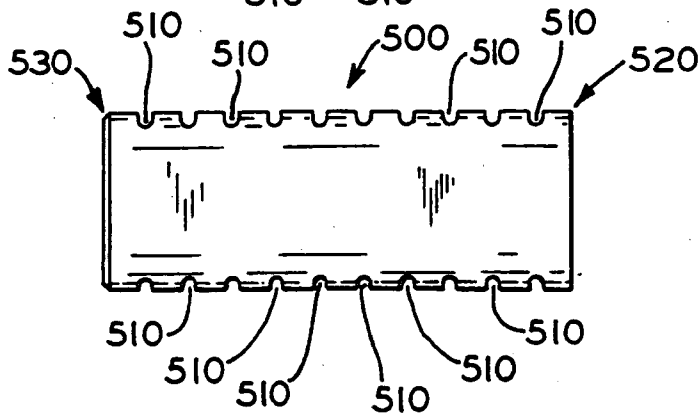

FIG. 39

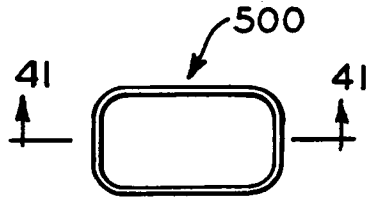

FIG. 40

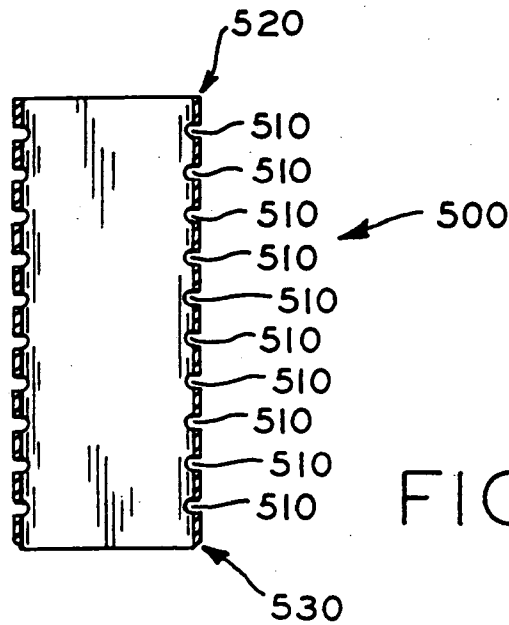

FIG. 41

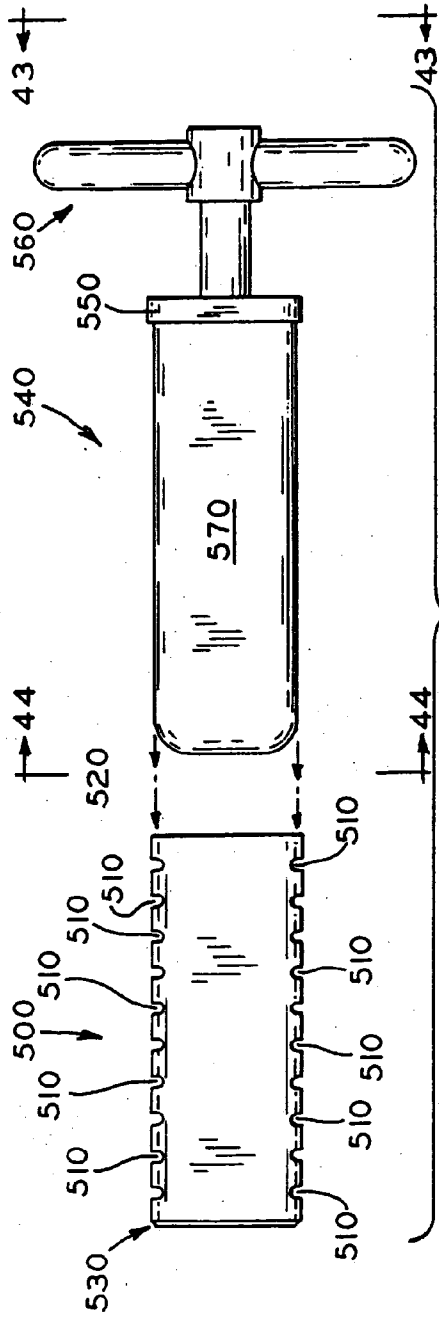

FIG. 42

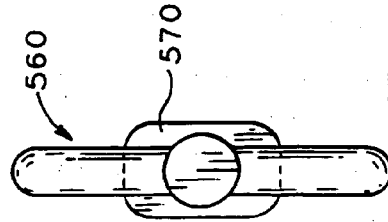

FIG. 43

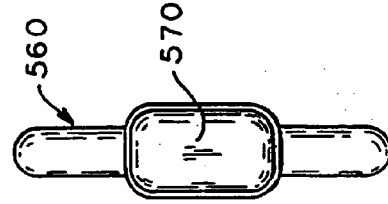

FIG. 44

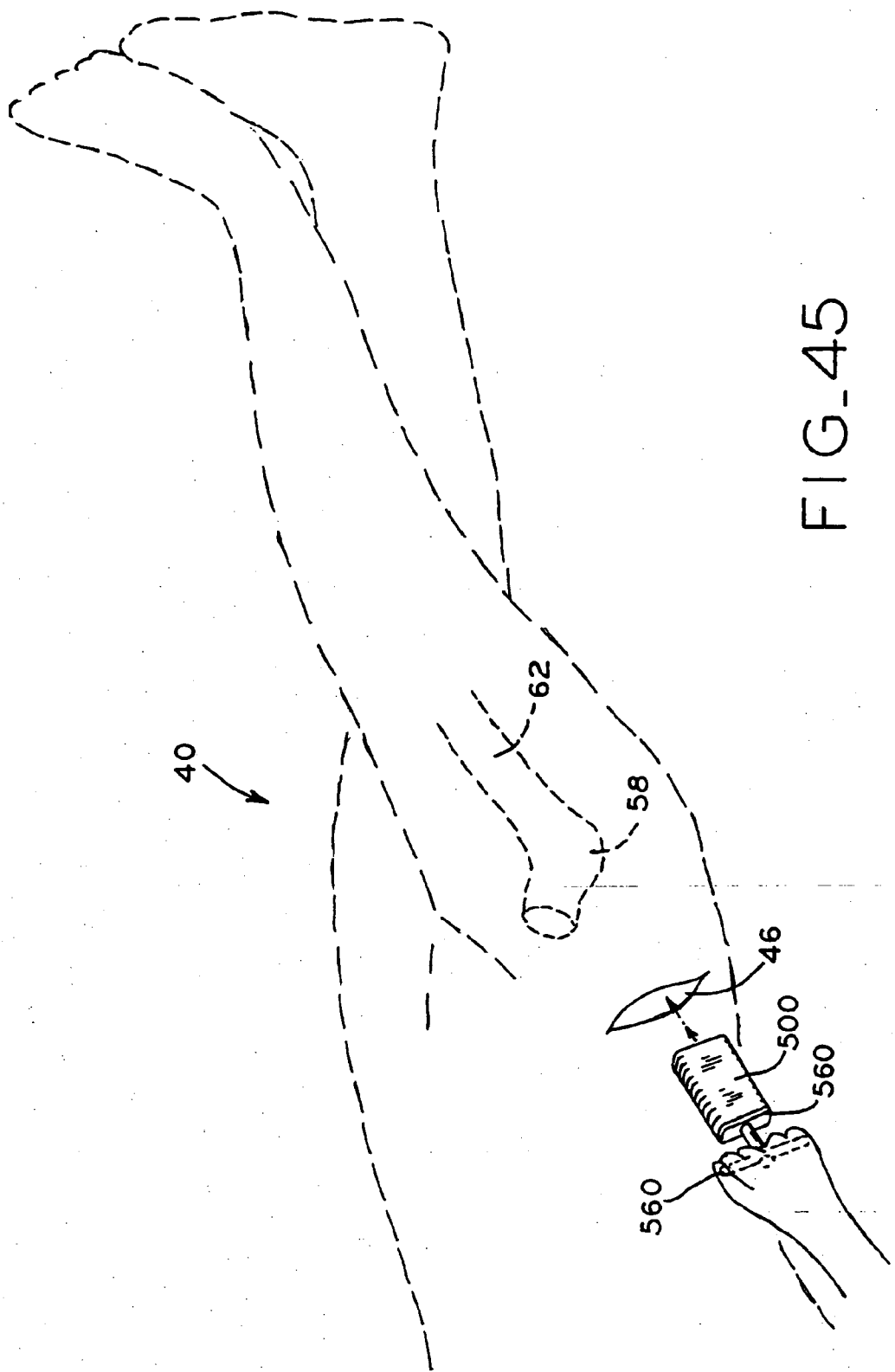

FIG. 45

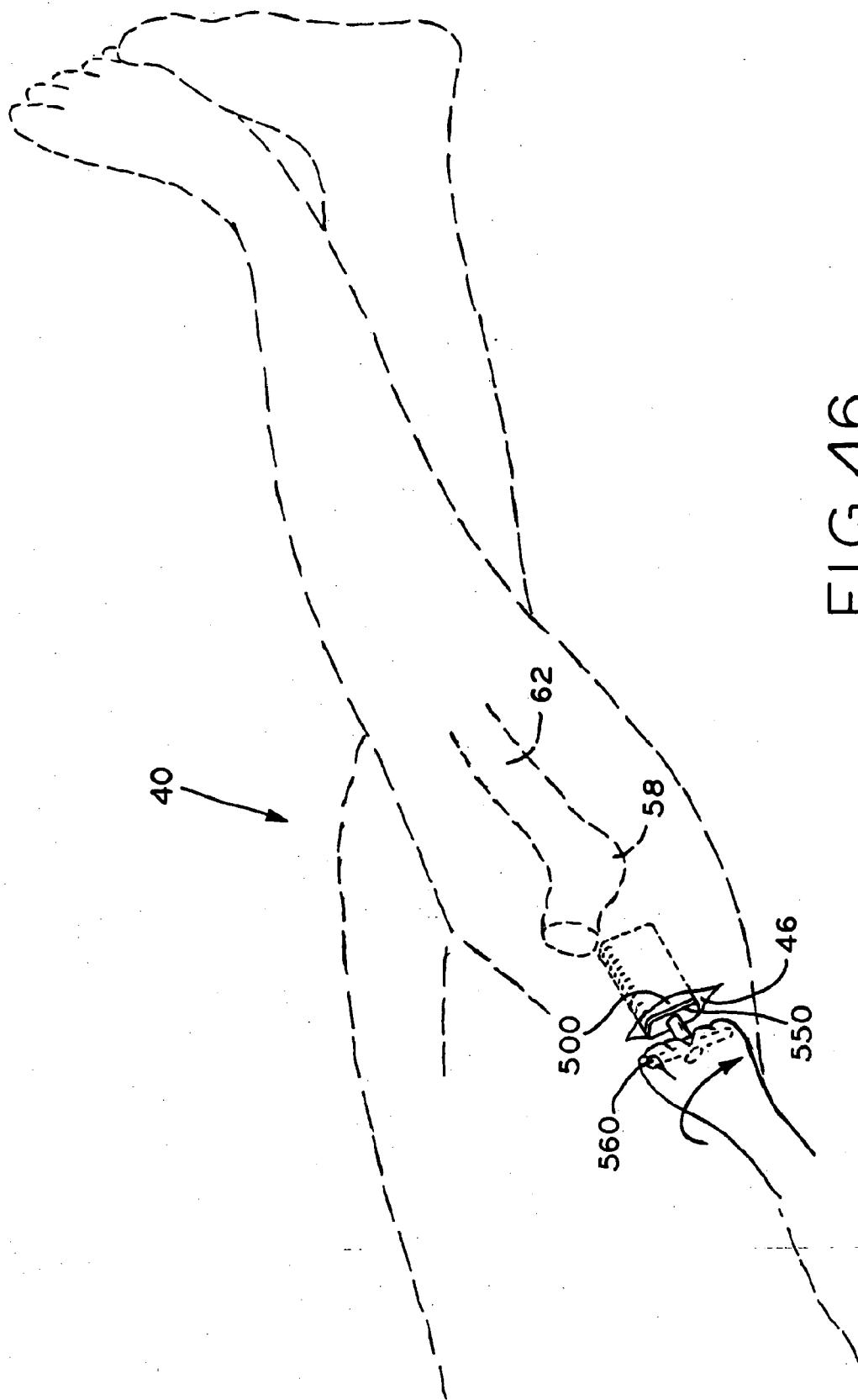

FIG. 46

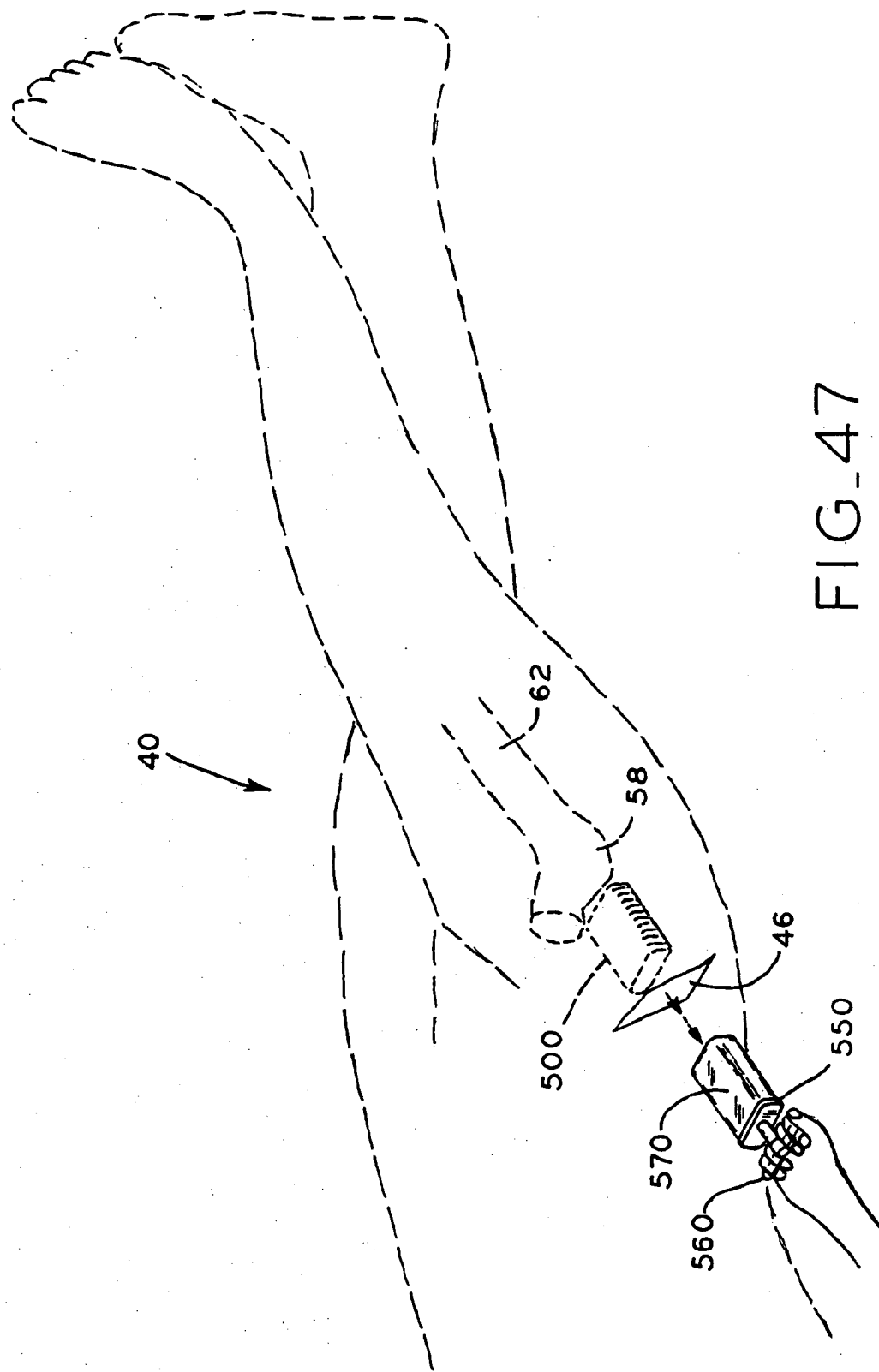

FIG. 47

**METHOD AND APPARATUS FOR PERFORMING A MINIMALLY INVASIVE TOTAL HIP ARTHROPLASTY**

**CROSS-REFERENCE TO RELATED APPLICATIONS**

[0001] This application is a divisional of co-pending U.S. patent application Ser. No. 10/952,301, filed on Sep. 28, 2004, published as U.S. Patent Application Publication No. U. S. 2005/0043810, which is a divisional of U.S. patent application Ser. No. 09/992,639, filed on Nov. 6, 2001, now U.S. Pat. No. 6,860,903, which is a continuation-in-part of U.S. patent application Ser. No. 09/558,044, filed on Apr. 26, 2000, now U.S. Pat. No. 6,676,706, the disclosures of which are hereby explicitly incorporated by reference herein.

**BACKGROUND**

[0002] 1. Field of the Invention

[0003] The present invention relates to total hip arthroplasty, and, more particularly, to a method and apparatus for performing a minimally invasive total hip arthroplasty.

[0004] 2. Description of the Related Art

[0005] Orthopedic procedures for the replacement of all, or a portion of, a patient's joint have been developed over the last 30 years. Currently, the procedures used to prepare the bone and seat the implants are generally referred to as open procedures. For the purpose of this discussion, the term open procedure will refer to a procedure wherein an incision is made through the skin and underlying tissue to fully expose a large portion of the particular joint surface. In the case of a total hip arthroplasty, the typical incision required is approximately 25 centimeters (10 inches) long. After the initial incision in the skin, the internal wound may be enlarged in order to fully expose the areas to be prepared. While this approach provides surgeons with an excellent view of the bone surface, the underlying damage to the soft tissue, including the muscles, can lengthen a patient's rehabilitation time after surgery. While the implants may be well fixed at the time of surgery, it may be several weeks or perhaps months before the soft tissues violated during surgery can fully heal.

**SUMMARY**

[0006] The present invention provides an improved method and apparatus for performing a minimally invasive total hip arthroplasty. A total hip arthroplasty can be performed in accordance with the teachings of the current invention utilizing two incisions, with the size of each of the wounds developed on the surface being substantially constant throughout the depth of the wound. The first incision is an anterior incision approximately 3.75-5 centimeters (1.5-2 inches) in length made in line with the femoral neck and the central axis of the acetabulum. The second incision is a posterior incision approximately 2.5-3.75 centimeters (1-1.5 inches) positioned to be generally in axial alignment with the femoral shaft. Access from the posterior incision to the femoral shaft is provided by a tubular retractor.

[0007] The femoral head is severed from the femoral shaft and removed through the anterior incision. The acetabular cup is placed in the acetabulum through the anterior incision, while the posterior incision is used to prepare the femoral

shaft to receive a femoral stem. After preparation of the femoral shaft, a trial reduction is performed, with a provisional femoral neck and provisional femoral head being operably positioned through the anterior incision. Once the trial reduction is satisfactorily completed, the hip is dislocated and the provisional head and neck are removed. A final femoral stem is then inserted through the posterior incision and positioned in the femoral shaft. Procedures performed through the posterior incision may be observed through the anterior incision and vice versa.

[0008] For the purpose of the following discussion, a total hip arthroplasty is defined as a replacement of the femoral head with or without the use of a separate acetabular component. The specific designs which can be utilized in accordance with the present invention include a total hip replacement and a bipolar or monopolar endoprosthesis. The technique is suitable for cemented or cementless anchorage of the components.

[0009] In one form thereof, the disclosure provides a provisional femoral head, including a spherical body having a generally cylindrical internal aperture formed in a distal end of the spherical body, the internal aperture sized to accommodate a provisional femoral neck, the spherical body further including a first clamp aperture sized to receive a first blade end of a clamp.

[0010] In another form thereof, the disclosure provides a provisional femoral head, including a spherical body having a generally cylindrical internal aperture formed in a distal end of the spherical body, the internal aperture sized to accommodate a provisional femoral neck, the spherical body further including a first clamp aperture sized to receive a first blade end of a clamp and a second clamp aperture sized to receive a second blade end of the clamp, the first and second clamp apertures extending through an exterior wall of the spherical body, the first and second clamp apertures forming a first opposing pair of clamp apertures into which the first and second blades of the clamp can be positioned to secure the provisional femoral head to the clamp.

[0011] The provisional femoral head of the present invention advantageously allows for positioning thereof on a provisional femoral neck in a radial fashion with respect to the provisional femoral neck, thus facilitating placement of the provisional femoral head through the relatively small sized anterior incision of the present invention.

[0012] The apparatus and method of the current invention advantageously allow a total hip arthroplasty to be performed in a minimally invasive way, which hastens patient recovery.

**BRIEF DESCRIPTION OF THE DRAWINGS**

[0013] The above-mentioned and other features and advantages of this invention, and the manner of attaining them, will become more apparent and the invention itself will be better understood by reference to the following description of an embodiment of the invention taken in conjunction with the accompanying drawings, wherein:

[0014] FIG. 1 is a side elevational view of a patient illustrating a pair of incisions made according to the current invention as well as the incision utilized in prior art procedures;

[0015] FIG. 2 is an anterior elevational view of a hip joint illustrating the femoral neck axis;

[0016] FIG. 2A is an anterior elevational view illustrating the capsule of the hip joint;

[0017] FIG. 3 is an anterior elevational view of the femoral neck exposed by incising the hip capsule;

[0018] FIG. 4 is an anterior elevational view of the femoral neck with an osteotomy guide of one form of the current invention operably positioned to designate a cut line thereon;

[0019] FIG. 5A is a side elevational view of an alternative embodiment of an osteotomy guide in accordance with the present invention;

[0020] FIG. 5B is an elevational view thereof taken along the longitudinal axis of the handle;

[0021] FIG. 6 is an anterior elevational view illustrating the femoral head and neck severed along the cut line indicated by the osteotomy guide;

[0022] FIG. 7 is an anterior elevational view illustrating the removal of a portion of the femoral head and neck;

[0023] FIGS. 8A and 8B illustrate preparation of the acetabulum to receive the acetabular cup;

[0024] FIG. 9 is a side elevational view of an acetabular cup inserter relative to a patient lying in the supine position;

[0025] FIG. 10 is an anterior elevational view of a portion of the cup inserter illustrated in FIG. 9 and a patient lying in the supine position;

[0026] FIG. 11 is a side elevational view illustrating the use of a curved awl to locate a posterior incision;

[0027] FIG. 12 is a side elevational, partial sectional view of an awl in accordance with the present invention;

[0028] FIG. 13 is a perspective view illustrating the insertion of a posterior retractor in the posterior incision;

[0029] FIG. 14 is a perspective, exploded view of one embodiment of a tubular retractor in accordance with the present invention;

[0030] FIG. 14A is a side elevational view of an alternative embodiment of the tubular retractor;

[0031] FIG. 15 is a perspective view illustrating the insertion of a guide wire into the tubular retractor;

[0032] FIG. 16 is a perspective view illustrating reaming of the femoral shaft;

[0033] FIG. 17A is a perspective view of an end cutter;

[0034] FIG. 17B is a perspective view of a femoral reamer;

[0035] FIG. 18 is a side elevational, partial sectional view of an end cutter inserted into a tubular retractor of the present invention;

[0036] FIG. 19 is a perspective view of a rasp handle after inserting a rasp into the femoral shaft;

[0037] FIG. 19A is a perspective view illustrating an inserted rasp, with the rasp handle removed, and with the cable used to affix the rasp to the rasp handle protruding from the posterior incision;

[0038] FIGS. 20A and 20B are partial sectional views of the rasp handle;

[0039] FIG. 21 is an exploded view of the rasp handle and a rasp to be connected thereto;

[0040] FIG. 21A is a partial elevational view along line 21A-21A of FIG. 21;

[0041] FIG. 22 is a perspective view illustrating placement of a provisional neck of the present invention;

[0042] FIG. 23 is a perspective view of the provisional neck and mating forceps of the present invention;

[0043] FIG. 24A is a partial sectional, radial elevational view of the provisional neck;

[0044] FIGS. 24B and 24C are radial elevational views thereof;

[0045] FIG. 25 is a perspective view illustrating the insertion of a femoral stem with a protective bag through the posterior incision;

[0046] FIG. 26 is a perspective view illustrating alignment of the femoral stem while observing through the anterior incision;

[0047] FIG. 27 illustrates an incision into the femoral stem protective bag prior to insertion of the femoral stem into the femoral shaft;

[0048] FIG. 28 is a perspective view illustrating removal of the femoral stem protective bag while inserting the femoral stem, with observation through the anterior incision;

[0049] FIG. 29 is a perspective view of a femoral stem insertion tool in accordance with the teachings of the present invention;

[0050] FIG. 30 is a perspective view of a hip prosthesis which can be implanted according to the method of the current invention;

[0051] FIG. 31 is a plan view of a provisional neck and a provisional head in accordance with the present invention;

[0052] FIG. 32 is a proximal plan view of the provisional head of FIG. 31;

[0053] FIG. 33 is a sectional view thereof;

[0054] FIGS. 34 and 35 are plan and sectional views, respectively, of an alternative embodiment provisional head in accordance with the present invention;

[0055] FIGS. 36 and 37 are plan and sectional views, respectively, of another alternative embodiment provisional head in accordance with the present invention;

[0056] FIGS. 38-40 are plan views of a posterior retractor sleeve of the present invention;

[0057] FIG. 41 is a sectional view thereof;

[0058] FIG. 42 is a plan view of the posterior retractor sleeve of FIGS. 38-41 and a mating occluder;

[0059] FIGS. 43 and 44 are end views of the occluder of FIG. 42; and

[0060] FIGS. 45-47 are perspective views illustrating insertion of the posterior retractor sleeve of FIGS. 38-41 into patient 40.

[0061] Corresponding reference characters indicate corresponding parts throughout the several views. The exemplification set out herein illustrates one preferred embodiment of the invention, in one form, and such exemplification is not to be construed as limiting the scope of the invention in any manner.

#### DETAILED DESCRIPTION

[0062] A total hip arthroplasty can be performed, according to the teachings of the current invention through two incisions, each no more than 5 centimeters (2 inches) in length. An anterior incision is made along the axis of the femoral neck, while a posterior incision is made generally in axial alignment with the femoral shaft. Referring to FIG. 1, a partial illustration of a patient 40 including torso 52, buttock 50, and leg 48 illustrates prior art incision 42 as well as anterior incision 44 and posterior incision 46 of the current invention. Prior art incision 42 is approximately 25 centimeters (10 inches) long, while anterior incision 44 and posterior incision 46 are each no more than 5 centimeters (2 inches) in length.

[0063] According to the method of total hip arthroplasty of the current invention, patient 40 is initially placed in a supine position on a conventional operating table. Referring now to FIG. 2, with leg 48 in a neutral position, two prominent bony landmarks are palpated, the anterior superior iliac spine (ASIS) 59 and the greater trochanter 58 of femur 62. Ilium 64 and pubis 66 of hip 68 are shown to better illustrate the relevant area of the body. The approximate anterior incision starting point 71 is identified two fingerbreadths inferior and two fingerbreadths anterior to the tubercle of greater trochanter 58. The approximate finish point for the anterior incision is identified three fingerbreadths inferior and two fingerbreadths lateral to the anterior superior iliac spine (ASIS) 59. With the use of a spinal needle, the appropriate starting point 71 and the path of the anterior incision are identified by impaling the skin down to bone to confirm the central axis 70 of femoral neck 60.

[0064] An oblique incision of approximately 3.75-5 centimeters (1.5-2 inches) is made from the starting site 71 toward the prominence of the greater trochanter along the axis 70 of the femoral neck 60 and the central axis of acetabulum 54. The incision is extended along the same plane through subcutaneous tissues, exposing the underlying fascia lata. The internervous plane between the tensor fascia lata muscle and the sartorius is identified by palpation and developed by curved scissors and blunt dissection. The sartorius can be made more prominent by externally rotating the leg to apply tension on the muscle. Deep to the tensor fascia lata and the sartorius is an internervous interval between the rectus femoris and the gluteus medius. This plane is developed by blunt dissection. A lateral retraction of the tensor fascia lata permits a visualization of the capsule 74 of the hip joint as illustrated in FIG. 2A.

[0065] Leg 48 is externally rotated to create tension on capsule 74. Capsule 74 is incised along the axis 70 (FIG. 2)

of femoral neck 60 from the equator of femoral head 56 to the intertrochanteric ridge on the femur 62. The capsular incision takes the form of an "H-shaped" window formed by incisions 72. The H-shaped window is formed by adding supplementary perpendicular limbs around the equator of the femoral head 56 and the base of the femoral neck 60 to the initial incision along the axis 70 of femoral neck 60. As a form of retraction, heavy sutures are used to provisionally attach the capsular flaps 73 to the subcutaneous tissues. As illustrated in FIG. 3, retractors 76 are placed inside capsular flaps 73 and underneath the superior and inferior borders of femoral neck 60 to expose the entire length of femoral neck 60 from the inferior aspect of femoral head 56 to the intertrochanteric ridge. In one exemplary embodiment, each retractor houses a light source and can also serve to anchor an endoscope. The retractors 76 thereby provide continuous visualization and illumination of the wound.

[0066] Referring now to FIG. 4, a femoral cutting tool 86, e.g., an oscillating saw or a power burr is used to excise femoral neck 60. A custom osteotomy guide 78 is placed through anterior incision 44 (FIG. 1) and functions to guide the femoral neck cut. Alignment portion 82 of osteotomy guide 78 is aligned with the longitudinal axis of femur 62, while cut guide 84 is positioned on femoral neck 60. Handle 80 of osteotomy guide 78 facilitates positioning and repositioning of osteotomy guide 78 through anterior incision 44. After placement of osteotomy guide 78, cut line 85 is scored as is known in the art. Osteotomy guide 78 is thereafter removed through anterior incision 44 and femoral cutting tool 86 is inserted through anterior incision 44 and utilized to cut along cut line 85 and displace portion 88 (FIG. 6) from femur 62.

[0067] Retractors 76 are repositioned around the anterior and posterior rims of the acetabulum. As is known in the art, a custom curved cutting tool. (i.e., the "ligamentum teres cutter") is passed behind femoral head 56 to sharply incise the ligamentum teres, thus mobilizing cut portion 88 as illustrated in FIG. 6. Cut portion 88 includes femoral head 56 as well as a portion of femoral neck 60 (FIG. 4). Cut portion 88 is thereafter removed through anterior incision 44 with a custom femoral head bone grasper 94 (FIG. 7). If there is difficulty removing cut portion 88 in one piece, it may be in situ morselized using cutting tool 87 (FIG. 6), e.g., a power burr. Morsels 92 may then be removed through anterior incision 44. Morselizing of cut portion 88 is accomplished making cuts which substantially mirror the cuts in hip capsule 74. Irrigation and suction devices can be used to cool the bone and facilitate the removal of bony debris in hip capsule 74. In one exemplary embodiment, a fiber optic endoscope is placed into the hip joint to confirm the complete removal of bony debris.

[0068] As illustrated in FIG. 8A, the fibro-fatty tissue within the cotyloid fossa of acetabulum 54 is removed with the use of, e.g., a high-speed acorn-tipped cutting tool 96, Rongeur forceps, and a curette. Thereafter, the acetabular labrum is trimmed with a scalpel. As illustrated in FIG. 8B, acetabulum 54 is then progressively reamed with standard acetabular reamer 98. Acetabular reamers within a predetermined size range are utilized until the optimal size of the acetabulum is reached. Sizing of the acetabulum is facilitated by the use of pre-operative templates and radiographs as is known in the art. Once again, an endoscope can be used to aid in visualization during the reaming process. Typically



the acetabulum is under reamed by approximately 2 mm with respect to the diameter of the anticipated acetabular cup so as to create an interference fit. High speed acorn-shaped cutting tool **96**, and acetabular reamer **98** enter the body through anterior incision **44**.

[0069] After a trial fitting, a press-fit acetabular cup of the appropriate size is firmly seated with cup inserter **100** as illustrated in FIG. **9** and impacted into the acetabular recess as is known in the art. Proper positioning of the acetabular cup is achieved with a custom anteflexion and pelvic alignment guide. Patient **40** is placed in supine position on operating table **102**. Aligning rod **104** is aligned with the mid lateral axis of torso **52** while main shaft **105** is maintained approximately 30° from operating table **102** for proper seating of the acetabular cup. To augment fixation of the cup, a flexible drill can be used to guide the placement of one or more acetabular screws. The insertion of the acetabular liner is deferred until the proximal femur has been prepared for the insertion of a trial stem. As illustrated by the anterior elevational view of FIG. **10**, patient **40** remains in the supine position on operating table **102** (FIG. **9**) while cup inserter **100** is utilized to seat the acetabular cup.

[0070] For preparation of the femur, the patient is repositioned with a pad placed under the ipsilateral hip. The hip is slightly flexed, adducted approximately 30°, and maximally externally rotated. Retractors **76** are repositioned around the medial and lateral aspects of femur **62**. Alternatively, a self-retaining retractor with a light source attachment and an endoscope holder can be positioned in anterior incision **44** to provide constant visualization and illumination of femur **62**.

[0071] With a scalpel or curved osteotome, the soft tissues along the anterior surface of femur **62** just inferior to the intertrochanteric ridge are subperiosteally reflected to expose the bone for a width of approximately 1 cm. This sharp subperiosteal elevation continues superolaterally onto the anterior margin of the greater trochanter. Then with curved Mayo scissors a pathway is developed by blunt dissection that is directed superficially to the anterior fibers of the gluteus minimus towards buttock **50** (FIG. **11**).

[0072] As illustrated in FIG. **11**, awl **106** is inserted through the anterior incision **44**, directed superficially to the cleft in the gluteus minimus, and advanced into the soft tissues of buttock **50** until its pointed distal end **108** can be palpated on the surface of the skin. Distal end **108** of awl **106** is generally aligned with the longitudinal axis of femur **62**. At the point where distal end **108** is palpated, posterior incision **46** of approximately 2.5-3.75 cm (1-1.5 inches) is made and extended through the subcutaneous tissues and fascia lata to expose the underlying gluteus maximus. A tract to femur **62** is developed along the path created by awl **106**. The gluteus maximus is split bluntly in line with its fibers with curved Mayo scissors. Into this pathway via posterior incision **46**, custom elliptical posterior retractor **122**, complete with its inner sleeves, is threaded (FIG. **13**) down to the osteotomized femoral neck. In one exemplary embodiment, elliptical posterior retractor **122** includes posterior lip **128** (FIG. **14**). In this embodiment, retractor **122** is threaded down to the osteotomized femoral neck until posterior lip **128** lies beneath the posterior intertrochanteric ridge. FIG. **14A** illustrates an embodiment of rasp tunnel **130** without posterior lip **128**. In an alternative embodiment, each component of posterior retractor **122** (i.e., guide tube **124**,

reamer tunnel **126**, and rasp tunnel **130**) is individually inserted and removed as necessary. In an embodiment in which guide tube **124**, reamer tunnel **126**, and rasp tunnel **130** are individually inserted and removed into posterior incision **46**, each individual tunnel may be provided with a posterior lip similar to posterior lip **128** illustrated in FIG. **14**.

[0073] In an alternative embodiment, posterior retractor sleeve **500** (FIG. **38**) is used in lieu of elliptical posterior retractor **122**. As illustrated in FIGS. **38-41**, retractor sleeve **500** comprises a generally rectangular tube having proximal end **520**, distal end **530**, and apertures **510**. As illustrated, e.g., in FIGS. **38, 39**, and **41**, apertures **51** are generally elongate apertures formed in opposing side walls of posterior retractor sleeve **500**. Apertures **510** are oriented generally perpendicular to a longitudinal axis of posterior retractor sleeve **500**. Both elliptical posterior retractor **122** and posterior retractor sleeve **500** have a hollow interior sized to accommodate passage of surgical instruments therethrough. For the purposes of this document, "surgical instruments" refers to hand-held tools or implements generally used by health professionals for the performance of surgical tasks, including, e.g., the various instruments utilized to prepare the femur to receive the femoral stem.

[0074] Referring now to FIG. **42**, occluder **540** includes extension **570** sized to be placed within retractor sleeve **500**. When retractor sleeve **500** is placed about extension **570**, flange **550** abuts proximal end **520** of retractor sleeve **500**. Occluder **540** includes handle **560** to facilitate use thereof to place retractor sleeve **500** in patient **40** as illustrated in FIGS. **45-47**. As illustrated in FIG. **45**, posterior retractor sleeve **500** is placed about occluder **540**, with flange **550** abutting posterior retractor **500**. Handle **560** is manipulated to place posterior retractor sleeve **500** in posterior incision **46** as illustrated in FIG. **46** and is thereafter utilized to turn posterior retractor sleeve **500** to the final position illustrated in FIG. **47**. Occluder **540** is then removed from posterior retractor sleeve **500** as illustrated in FIG. **47**. In operable position, apertures **510** of posterior retractor sleeve **500** are occupied with tissue of patient **40** to thereby maintain the position of posterior retractor sleeve **500** within patient **40**. The remainder of this document refers to use of elliptical posterior retractor **122**, however, retractor sleeve **500** can be utilized in lieu of posterior retractor **122** to provide access to femur **62** through posterior incision **46**.

[0075] Referring now to FIG. **15**, blunt tipped guide wire **146** is inserted through guide tube **124** of posterior retractor **122** and advanced into femoral canal **148**. While FIG. **15** illustrates guide tube **124** nested in reamer tunnel **126** and rasp tunnel **130**, guide tube **124** may be directly inserted through posterior incision **46**. If the cancellous bone of femur **62** is too dense to permit insertion of blunt tipped guide wire **146**, then a conical cannulated reamer or end mill is used to prepare the femoral metaphysis. If a nested posterior retractor configuration is utilized, guide tube **124** must be removed so that the reamer can be inserted through reamer tunnel **126** of posterior retractor **122**. Similarly, if a nested configuration is not utilized, reamer tunnel **126** must be inserted into posterior incision **46**. In any event, blunt tipped guide wire **146** is inserted about halfway down femoral canal **148**. The following detailed description of the invention makes reference to a nested posterior retractor configuration. It will be understood by those skilled in the art

that if the nested configuration is not utilized, each individual component of posterior retractor 122 will be inserted and removed through posterior incision 46 as necessary.

[0076] FIG. 16 illustrates preparation of femoral canal 148 to receive rasp 204 (FIG. 19). Guide tube 124 is removed from posterior retractor 122 and end cutter 150 (FIG. 17A) is inserted through reamer tunnel 126. FIG. 18 illustrates end cutter 150 positioned within reamer tunnel 126. End cutter 150 includes elongate aperture 160 through which guide wire 146 passes and guides end cutter 150. End cutter 150 is actuated by any of the many actuating devices known in the art. After end cutting is complete, end cutter 150 is removed through reamer tunnel 126 and reamer 151 (FIG. 17B) is inserted therethrough. Reamer 151 includes reamer guide aperture 161 through which guide wire 146 passes and guides reamer 151 as it reams femoral canal 148. Reamers of progressive increase in their outer diameter are sequentially placed over guide wire 146 and femoral canal 148 is reamed until cortical "chatter" is felt. As is known in the art, the optimal diameter of femoral canal 148 is provisionally determined by preoperative templating. Some surgeons may choose to avoid reaming of the femoral shaft and instead utilize a broach as is known in the art. A broach may be inserted in accordance with the current invention as described hereinbelow with respect to rasp insertion.

[0077] After the correct diameter of femoral canal 148 is reamed out, reamer tunnel 126 (FIG. 14) is removed from posterior retractor 122 so that rasp 204 and rasp handle 212 (FIG. 19) can be inserted over guide wire 146 to complete preparation of femur 62. Guide wire 146 is inserted into rasp guide aperture 214 and rasp handle guide aperture 202 to guide rasp 204 to prepared femur 62. Impact surface 164 is struck, as is known in the art, to place rasp 204 in femur 62. While rasp 204 is being impacted, the rotational alignment can be assessed by direct visual scrutiny of femur 62 through anterior incision 44. Furthermore, assessment of the alignment of rasp handle 212 with respect to the patella, lower leg, and foot facilitates alignment.

[0078] Progressively larger rasps are inserted to achieve the optimal fit and fill in femur 62. Once the final rasp is fully seated, rasp handle 212 is removed along with guide wire 146 and posterior retractor 122, leaving distal end 208 of flexible cable 192 (FIG. 19A) attached to the proximal end of rasp 204 and proximal end 194 of flexible cable 192 protruding from posterior incision 46. The operation of rasp handle 212 will be further explained below.

[0079] After the final rasp is seated in femoral canal 148, a trial acetabular liner is placed through anterior incision 44 and into the seated acetabular cup with the use of a liner inserter as is known in the art. Provisional neck 222 is inserted through anterior incision 44 and locked to the top end of the seated rasp, as illustrated in FIG. 22. A trial femoral head is thereafter placed on the Morse taper of provisional neck 222 through anterior incision 44. Referring to FIGS. 31-37, provisional head 400 is adapted for placement on provisional neck 222. Provisional head 400 includes a spherical body having a generally cylindrical internal aperture formed of tapered portion 470 and proximal portion 472. Provisional head 400 further includes cutout 450 positioned to allow radial placement of provisional head 400 on provisional neck 222 as illustrated in FIG. 31. After provisional neck 222 traverses cutout 450,

provisional head 400 is axially displaced along proximal neck 222 until snap ring 410 on provisional neck 222 engages snap ring groove 480 on provisional head 400 and taper 460 on provisional neck locks with taper 470 on provisional head 400. Clamp apertures 440 are positioned in provisional head 400 to receive the blade end(s) of a clamp (not shown) utilized to position provisional head 400. Provisional head 400 further includes vent hole 490 to allow bodily fluid and debris to be ejected from the internal aperture of provisional head 400 when provisional head 400 is positioned on provisional neck 222. FIGS. 34 and 35 illustrate an alternative embodiment of provisional head 400 having shallower tapered portion 470' relative to tapered portion 470 of the provisional head illustrated in FIGS. 31-33. FIGS. 36 and 37 illustrate another alternative embodiment of provisional head 400 in which distal end 420" forms a generally cylindrical extension from the spherical body of provisional head 400". After placement of provisional head 400, the hip joint is reduced for an assessment of stability of the hip joint and limb length. Where necessary, a second assessment is made.

[0080] Once the trial reduction is satisfactorily completed, the hip is dislocated and the provisional head and provisional neck 222 are removed. Rasp handle 212 is reinserted through posterior incision 46 over the free end of flexible cable 192. Rasp handle 212 is advanced until it can be locked with the seated rasp so that impact surface 164 can be impacted and the entire tool (i.e., rasp 204 and rasp handle 212) can be removed. The trial acetabular liner is removed through anterior incision 44.

[0081] Via anterior incision 44, the final acetabular liner 252 (FIG. 30) is seated into acetabular cup 250 (FIG. 30) with a liner inserter that permits its impaction in place, as is known in the art. Femoral implant 238 (FIG. 30) is anchored to femoral stem insertion tool 240 (FIG. 29) and placed through posterior incision 46. As illustrated in FIG. 25, femoral implant 238 is placed in protective, disposable bag 242 prior to its introduction into posterior incision 46. Protective, disposable bag 242 keeps femoral implant 238 clean as it is inserted through posterior incision 46. Note that FIG. 25 illustrates femoral implant 238 oriented as it will be when placed in femur 62. To insert femoral implant 238 through posterior incision 46, femoral implant 238 must be rotated 180° from this position to prevent impingement on the body. Femoral implant 238 is then rotated 180° after being completely inserted through posterior incision 46.

[0082] FIG. 26 illustrates femoral stem 238 and bag 242 inserted through posterior incision 46. When the tip of femoral stem 238 approaches the osteotomized femoral neck, the distal end of bag 242 is incised as illustrated in FIG. 27. Scalpel 246 is inserted into anterior incision 44 to incise bag 242. As femoral stem 238 is driven into femoral canal 148, bag 242 is progressively removed through posterior incision 46 as illustrated in FIG. 28. After femoral stem 238 is fully seated, femoral stem insertion tool 240 (FIG. 29) is removed through posterior incision 46. Through anterior incision 44, the final femoral head is positioned on the femoral neck Morse taper using a standard holding device and secured with a standard impaction tool and mallet. The hip is then reduced and assessed for stability.

[0083] After appropriate antibiotic irrigation, the hip capsule and the soft tissues are repaired with heavy sutures or

staples. A suitable local anesthetic solution is injected into the closed hip joint as well as the capsular layer and the subcutaneous tissues, allowing superior postoperative pain relief. The fascial layers, subcutaneous tissues, and skin of both anterior and posterior wounds are closed in a conventional method and dressings are applied. A suction drain may be used at the discretion of the surgeon.

[0084] Osteotomy guide **78**, illustrated in use in FIG. 4, includes handle **80**, alignment portion **82**, and cut guide **84**. In one exemplary embodiment, cut guide **84** and alignment portion **82** form a 60° angle. In one exemplary embodiment, alignment portion **82** includes a tapered distal end as illustrated in FIGS. 5A and 5B. Osteotomy guide **78** is inserted through anterior incision **44** and is positioned with alignment portion **82** being placed on femur **62** so that alignment portion **82** generally aligns with the longitudinal axis of femur **62**. Handle **80** protrudes through anterior incision **44** and may be utilized to position osteotomy guide **78**. After osteotomy guide **78** is properly positioned, cut guide **84** is utilized to mark cut line **85** on femoral neck **60** as illustrated in FIG. 4. Osteotomy guide **78** can be formed to function on either side of the body. FIG. 4 illustrates an osteotomy guide designed to function on the right femur, while FIG. 5B illustrates an osteotomy guide operable to function on the left femur.

[0085] As discussed supra, awl **106** (FIG. 12) is designed for insertion through anterior incision **44** to locate posterior incision **46** (FIG. 11). Awl shaft **116** includes proximal end **110** designed for insertion into handle **112**. Handle **112** includes a longitudinal channel **120** into which proximal end **110** of awl shaft **116** may be inserted. Locking screw **118** is operably positioned in handle **112** and may be actuated by locking knob **114**. Locking knob **114** is utilized to place locking screw **118** in locking engagement with proximal end **110** of awl **106**. In one exemplary embodiment, proximal end **110** of awl **106** includes a flat portion to engage locking screw **118** and facilitate the locking engagement of awl shaft **116** to handle **112**. Awl shaft **116** further includes distal end **108**. Distal end **108** is generally straight and is utilized to generally align with a longitudinal axis of femur **62** (FIG. 11). As illustrated in FIG. 12, distal end **108** of awl shaft **116** includes a tapered end to facilitate insertion of awl **106** through anterior incision **44** to locate posterior incision **46**. Additionally, distal end **108** of awl **106** may be of smaller diameter than the body of awl shaft **116** as illustrated in FIG. 12. In an alternative embodiment, awl **106** is formed in one piece and is disposable.

[0086] Referring now to FIG. 14, posterior retractor **122** comprises three nested parts. Guide tube **124** is nested in reamer tunnel **126** while reamer tunnel **126** is nested in rasp tunnel **130**. When posterior retractor **122** is threaded into posterior incision **46**, guide tube **124**, reamer tunnel **126**, and rasp tunnel **130** can be nested together to form a single unit. Rasp tunnel **130** includes exterior threads **132** to facilitate threading of posterior retractor **122** through posterior incision **46**. Rasp tunnel **130** includes rasp aperture **134** through which reamer tunnel **126** may be inserted and, in one alternative embodiment, posterior lip **128** for positioning posterior retractor **122**, as discussed above. Reamer tunnel **126** includes flange **136** which is operable to retain the position of reamer tunnel **126** within rasp tunnel **130**. Reamer tunnel **126** includes reamer aperture **138** through which guide tube **124** may be inserted. Guide tube **124**

includes a tapered distal end **140** to facilitate its insertion into reamer aperture **138**. Guide tube **124** includes guide wire aperture **144** through which guide wire **146** (FIG. 15) may be inserted. Reamer aperture **138** is sized to allow insertion of end cutter **150** (FIG. 18), or femoral reamer **151** as discussed above. As illustrated in FIG. 18, guide tube **124** is removed from reamer tunnel **126** and end cutter **150** is inserted through reamer aperture **138**. Longitudinal reamer aperture **138** is sized to accommodate guide cylinders **156** and to thereby provide guidance and stability to end cutter **150**. After end cutting (and reaming, if desired) is complete, reamer tunnel **126** is removed from rasp tunnel **130**. Rasp aperture **134** is sized to accommodate insertion of rasp **204** as well as cannular insertion member **168** of rasp handle **212**. For surgeries which do not utilize reaming, the posterior retractor can comprise a rasp tunnel with a guide tube nested therein and not include a reamer tunnel as described above. As described above, posterior retractor **122** is not always utilized in its nested configuration. In one exemplary embodiment, guide tube **124**, reamer tunnel **126**, and rasp tunnel **130** are each inserted into and removed from posterior incision **46** as necessary.

[0087] Referring now to FIG. 21, rasp handle **212** includes cannular insertion member **168**, impact surface **164**, grip **166**, elongate guide aperture **202**, elongate aperture **200**, and engagement channel **190**. Rasp **204** includes an aperture **216** sized to receive and retain retainer **210** on distal end **208** of flexible cable **192**. Retainer **210** is placed in aperture **216** and flexible cable **192** follows cable channel **217** to exit rasp **204**. Proximal end **194** of flexible cable **192** is inserted through elongate aperture **200** of cannular insertion member **168** and distal rasp engagement guide **206** is piloted to guide channel **215** of rasp **204**. After exiting the proximal end of elongate aperture **200**, proximal end **194** of flexible cable **192** may be received in engagement channel **190**. Engagement channel **190** is sized to accommodate and retain retainer **196**. After retainer **196** is operably positioned in engagement channel **190**, grip **166** may be actuated to tension flexible cable **192**.

[0088] Referring now to FIG. 20B, retainer **196** is operably positioned in engagement channel **190**. Attaching means **184**, such as, e.g., rivets, belts, etc. are utilized to affix biasing elements **172** to grip **166** and internal handle surface **182**. Grip **166** is outwardly biased by handle biasing elements **172** and pivots about pivot point **198**. Grip **166** includes tensioning member **188** and ratchet **174**. Ratchet **174** is designed for engagement with tapered end **186** of pawl **176**. Pawl **176** includes pawl flange **178**. Spring **180** engages internal handle surface **82** and pawl flange **178** to bias pawl **176** toward cannular insertion member **168**. Actuation of grip **166** against the biasing force of biasing elements **172** rotates grip **166** about pivot point **198**, causes ratchet **174** to come into operative engagement with tapered end **186** of pawl **176**, and causes tensioning member **188** to contact flexible cable **192**. FIG. 20A illustrates grip **166** retained by pawl **176** in the closed position. As illustrated, tensioning member **188** contacts and tensions flexible cable **192**, thus locking rasp **204** to rasp handle **212**. Lock disengagement knob **170** can be pulled against the biasing force of spring **180** to unlock grip **166**.

[0089] Referring now to FIG. 23, provisional neck **222** can be locked to rasp **204** utilizing forceps **220**. Forceps **220** include blade ends **230**, **232**. Blade ends **230**, **232** are sized

for insertion into provisional head apertures **234**, **236**, respectively (FIGS. **24B** and **24C**). As illustrated in FIG. **24A**, provisional neck **222** includes locking cylinder **224** and spring **228**. Spring **228** upwardly biases locking cylinder **224**. Upon insertion into apertures **234**, **236**, blade ends **230**, **232** can contact tapered portion **226** of locking cylinder **224**. Actuation of blade ends **230**, **232** against tapered portion **226** causes locking piston **224** to move in a direction opposite to the biasing force of spring **228**. Provisional neck **222** is clamped to forceps **220** and slid in a radial direction into provisional neck engagement area **218** (FIGS. **21** and **21A**) on rasp **204**. After provisional neck **222** is fully slid onto rasp **204**, forceps **220** may be released, thereby allowing locking piston **224** to return to its locked position under the biasing force of spring **228**. Rasp **204** includes circular cut outs **217** which can be engaged by locking cylinder **224** to lock provisional neck **222** in place.

[0090] Channels **225** (FIG. **24A**) on provisional neck **222** accommodate protrusions **219** (FIG. **21**) on rasp **204**. Provisional neck **222** is slid onto rasp **204** with protrusions **219** occupying channels **225** of provisional neck **222**. Stop **223** of provisional neck **222** abuts protrusions **219** when provisional neck **222** is completely slid onto rasp **204**. When stop **223** abuts protrusions **219**, locking cylinder **224** may be locked (i.e., forceps blades **230**, **232** released) so that locking cylinder **224** engages circular cut outs **217**, locking provisional neck **222** to rasp **204**.

[0091] While the method of the current invention has been described with reference to a particular hip prosthesis, this is not meant to be limiting in any way and it will be understood that the method of the current invention could be used with many prosthetics, including, e.g., a cementless prosthesis, a hybrid prosthesis having a cemented stem and a cementless acetabular cup, a cemented prosthesis having both a cemented stem and a cemented acetabular cup, or an Endo prosthesis for replacing only the femoral head. In a procedure in which a cemented femoral stem is utilized, the bone cement will generally be inserted through the anterior incision. It should also be understood by those skilled in the art that in a smaller patient the method of the current invention could be performed entirely through the anterior incision with no need to make a posterior incision as described above.

[0092] While this invention has been described as having an exemplary design, the present invention can be further modified within the spirit and scope of this disclosure. This application is therefore intended to cover any variations, uses, or adaptations of the invention using its general principles. Further, this application is intended to cover such departures from the present disclosure as come within known or customary practice in the art to which this invention pertains and which fall within the limits of the appended claims.

What is claimed is:

1. A provisional femoral head, comprising:

a spherical body having a generally cylindrical internal aperture formed in a distal end of said spherical body, said internal aperture sized to accommodate a provisional femoral neck, said spherical body further including a first clamp aperture sized to receive a first blade end of a clamp.

2. The provisional femoral head of claim 1, wherein said spherical body includes a cutout intersecting said internal aperture.

3. The provisional femoral head of claim 2, wherein said cutout is sized whereby a provisional femoral neck can traverse said cutout to be positioned within said internal aperture.

4. The provisional femoral head of claim 1, wherein said cylindrical internal aperture defines a curved interior wall of said spherical body.

5. The provisional femoral head of claim 4, further including a recess formed in said interior wall, said recess sized to accommodate a projection on the provisional femoral neck, whereby the provisional femoral head and the provisional femoral neck are engaged in an interference engagement.

6. The provisional femoral head of claim 5, wherein said interference engagement comprises a snap-fit engagement.

7. The provisional femoral head of claim 5, wherein said recess extends at least partially circumferentially around said curved interior wall.

8. The provisional femoral head of claim 5, wherein said projection extends at least partially circumferentially around the provisional femoral neck.

9. The provisional femoral head of claim 1, further comprising an extension portion extending from said spherical body and further defining said cylindrical internal aperture.

10. The provisional femoral head of claim 9, wherein said extension portion comprises a substantially cylindrical extension portion.

11. The provisional femoral head of claim 1, further comprising a second clamp aperture sized to receive a second blade end of said clamp, said first and said second clamp apertures extending through an exterior wall of said spherical body, said first and said second clamp apertures forming a first opposing pair of clamp apertures into which said first and said second blades of said clamp can be positioned to secure the provisional femoral head to said clamp.

12. The provisional femoral head of claim 11, further comprising a third clamp aperture and a fourth clamp aperture, said third and said fourth clamp apertures forming a second opposing pair of clamp apertures.

13. The provisional femoral head of claim 1, further comprising a vent aperture fluidly connecting said internal aperture and a proximal end of said spherical body.

14. A provisional femoral head, comprising:

a spherical body having a generally cylindrical internal aperture formed in a distal end of said spherical body, said internal aperture sized to accommodate a provisional femoral neck, said spherical body further including a first clamp aperture sized to receive a first blade end of a clamp and a second clamp aperture sized to receive a second blade end of said clamp, said first and said second clamp apertures extending through an exterior wall of said spherical body, said first and said second clamp apertures forming a first opposing pair of clamp apertures into which said first and said second blades of said clamp can be positioned to secure the provisional femoral head to said clamp.

15. The provisional femoral head of claim 14, further comprising a third clamp aperture and a fourth clamp

aperture, said third and said fourth clamp apertures forming a second opposing pair of clamp apertures.

**16.** The provisional femoral head of claim 14, wherein said spherical body includes a cutout intersecting said internal aperture.

**17.** The provisional femoral head of claim 16, wherein said cutout is sized whereby a provisional femoral neck can traverse said cutout to be positioned within said internal aperture.

**18.** The provisional femoral head of claim 14, wherein said cylindrical internal aperture defines a curved interior wall of said spherical body.

**19.** The provisional femoral head of claim 18, further including a recess formed in said interior wall, said recess sized to accommodate a projection on the provisional femoral neck, whereby the provisional femoral head and the provisional femoral neck are engaged in an interference engagement.

**20.** The provisional femoral head of claim 14, further comprising a vent aperture fluidly connecting said internal aperture and a proximal end of said spherical body.

\* \* \* \* \*