

(19)



Europäisches Patentamt

European Patent Office

Office européen des brevets



(11)

EP 0 572 700 B1

(12)

EUROPEAN PATENT SPECIFICATION

(45) Date of publication and mention
of the grant of the patent:
03.09.1997 Bulletin 1997/36

(51) Int. Cl.⁶: **B41J 13/22**, B41J 2/325

(21) Application number: **92109483.5**

(22) Date of filing: **04.06.1992**

(54) Paper holder of video printer

Papierhalter für einen Videodrucker

Support papier pour une imprimante vidéo

(84) Designated Contracting States:
DE FR GB

(43) Date of publication of application:
08.12.1993 Bulletin 1993/49

(73) Proprietor: **SAMSUNG ELECTRONICS CO., LTD.**
Suwon-City, Kyonggi-Do 441-370 (KR)

(72) Inventors:
• **Ro, Kwang-Ho**
Suwon-city, Kyonggi-do (KR)
• **Park, Moon-Bae**
Suwon-city, Kyonggi-do (KR)

(74) Representative: **Grünecker, Kinkeldey,**
Stockmair & Schwanhäusser
Anwaltssozietät
Maximilianstrasse 58
80538 München (DE)

(56) References cited:
EP-A- 0 340 925 **EP-A- 0 403 775**
EP-A- 0 495 411 **GB-A- 2 110 045**
US-A- 4 698 646 **US-A- 4 891 655**

• **PATENT ABSTRACTS OF JAPAN** vol. 11, no. 50
(M-562)17 February 1987 & JP-A-61 213 179
(MATSUSHITA ELECTRIC IND CO LTD) 22
September 1986

EP 0 572 700 B1

Note: Within nine months from the publication of the mention of the grant of the European patent, any person may give notice to the European Patent Office of opposition to the European patent granted. Notice of opposition shall be filed in a written reasoned statement. It shall not be deemed to have been filed until the opposition fee has been paid. (Art. 99(1) European Patent Convention).

Description

The present invention relates to a printing device enabling printing of various colors in sequence.

Generally, a video printer is used to print pictures recorded by momentarily acquiring a video signal and the picture to be reproduced on a monitor through a recording device such as a still camera. There has previously been disclosed a method of heat conductive sublimation for sublimating each of three colors of yellow (Y), magenta (M) and cyan (C) successively; this method enables a gradation of the color to be expressed freely, thus enabling expression with all of the colors from the video signal.

In conventional, commercially available multi-color printers, the platen drum must necessarily rotate after completion of printing in order to discharge the completely printed paper. In some models, even the direction of platen drum rotation must be reversed to be discharged. Generally, in currently available multi-color printers, to assure rotation of the completely printed paper during the discharge rotation of the platen drum, the thermal print head is positioned to press the printed paper and a portion of the dye-bearing color ribbon against the platen drum. This portion of the dye-bearing ribbon adjoins the three-color array of dyes used to print the paper, and is itself not necessary for printing of the paper. Consequently, the currently available printers and their processes require an additional length of ribbon solely to accommodate the frictional force required to be used between the platen, paper, ribbon and thermal print head during the final steps of advancing the finished paper toward discharge. In order to engage the additional portion of the ribbon however, the platen drum must rotate incrementally by the length of the additional portion of the ribbon, thereby further slowing the printing process. In summary, currently available printers and multi-color printing processes are unnecessarily wasteful of ribbon material and time.

EP-A-495 411 published on July 22, 1992 has a priority date of January 12, 1991 and designates contracting states DE, FR, GB, thus being state of the art pursuant Art 54(3) EPC.

In EP-A-495,411 a printing device is disclosed comprising a plate and a drum which provides a circumferential outer surface and a pair of brackets which are arranged in proximity to the axially opposite bases of the drum. The two brackets are connected by means of a holding bar which is urged against the circumferential outer surface of the drum for holding a piece of paper.

The object of the present invention is to provide a printing device which is simple in structure and thus, reliable in operation and may be manufactured with low costs.

This object is solved by a printing device comprising the features of claim 1. Preferred embodiments of the invention are subject to various dependent claims.

A more complete appreciation of this invention and many of the attendant advantages thereof will be readily

apparent as the same becomes better understood by reference to the following detailed description when considered in conjunction with the accompanying drawings in which like reference symbols indicate the same or similar components, and wherein:

Fig 1 is a schematic diagram of a conventional video printer;

Fig. 2 is a schematic diagram of a conventional paper holder and a bracket of a video printer;

Fig. 3 is a schematic diagram of another conventional paper holder and a bracket of a video printer, for addressing problems of the device of Fig. 2;

Fig. 4A and 4B are schematic diagrams illustrating a color ribbon cassette and the pattern of the color ribbon in a cassette suitable for the device of Fig. 3; Fig. 5 is block diagram for a video color printer constructed according to the principles of the present invention;

Fig 6 is an exploded perspective view of the paper holder and the bracket for a device constructed to incorporate the features of the embodiment of Fig. 5;

Fig. 6A is an exploded perspective view of an alternative embodiment of the paper holder and bracket; Fig. 6B is a perspective view of a print head assembly;

Figs. 7A to 7H are operational diagrams illustrating a sequence of relative portions of a paper holder of the inventive video printer constructed and operated according to the principles of the present invention; and

Figs. 8A and 8B are schematic diagrams illustrating a flow chart for the controller of Fig. 5.

Turning now to the drawings, Fig. 1 shows a video printer with an ink bearing ribbon 16 containing a dye of three consecutively arranged colors arranged, for example, is a sequence of yellow (Y), magenta (M) and cyan (C), a heat sensitive record medium paper such as a sheet of commercially available cut sheet or fan-fold paper 11, a platen drum 12 for moving the heat sensitive paper 11 and the ink bearing ribbon 16, and a thermal printing head (T.P.H.) 13 for selectively pressing the ribbon 16 and paper 11 against the platen drum 12.

If the platen drum 12 rotates after fixing paper 11 onto its outside surface, paper 11 and ink ribbon 16 advance at the speed of the platen drum 12. Each of the dyes Y, M and C is sublimated by the heat value generated by the thermal printing head 13, and is absorbed on paper 11. Different rates of the absorbed dyes Y, M and C of the ink borne by the ribbon enables various synthesized colors to be printed on paper 11 with different gradations so that the printing of all kinds of colors is made possible.

A device disclosed in US-A-4,815,870, is shown in Fig. 2. Heat sensitive paper 20 is supplied through the supplying port S to a clamp 25. A bracket 23 is rotated around a rotating axis 24 by a projecting pin 22 to ride

against an outside surface of a cam 21, with the result that clamp 25 presses against paper 20.

In printing of the Y, M and C ink dyes, platen drum 26 rotates counter-clockwise to complete the printing of the selected Y, M and C colors, by rotating three times. Platen drum 26 continuously rotates in a counter-clockwise direction so that the tip of paper 20 is delivered to an entrance of a discharging port O. Thereafter, the platen drum 26 rotates clockwise to discharge paper 20. At the time of discharge, clamp 25 releases paper 20 through action of cam 21.

As shown in Fig. 2, the supply port S and discharge port O are installed in approximately radially opposite directions from each other. Thus, the platen drum 26 rotates in a counter-clockwise direction in order to print the Y, M and C dyes. In order to discharge the completely printed paper (not shown), the platen drum 26 rotates counter-clockwise until the leading edge of paper 20 reaches the tip of the discharging port O, and thereafter the platen drum 26 rotates clockwise to discharge the printed paper.

Accordingly, in the configuration shown in Fig. 2, in addition to actual printing time required for printing of the Y, M and C dyes, more time is required for rotating the platen drum counter-clockwise so as to position the completely printed paper at the entrance of the discharging port O, and additional time is then required for rotating the platen drum clockwise to discharge the paper. Also, installation of a mechanism for rotating the platen drum in both directions is inevitable.

As shown in Fig. 3, there has previously been disclosed a holder for fixing or releasing paper 35 on or from the platen drum, wherein the holder 33 is installed around a shaft 31 of the platen drum 30, which is held around shaft 31 by a spring 32. A clamp bracket 34 actuates a side end of the holder 33 so as to let the holder fix or release the paper.

Paper 35 is transferred through a supply port SS to a front of holder 33. Bracket 34 is rotated around a shaft 36 counter-clockwise by a driving part (not shown) so that one arm 34a of bracket 34 pushes one arm 33a of holder 33. Therefore, holder 33 is lifted from the surface of platen drum 30 so as to receive paper 35. The voltage supply of the driving part (not shown) is then stopped so that bracket 34 returns to its original position under a restoring force of spring 32, with the result that holder 33, in unison with bracket 34, presses against, and thereby secures the position of paper 35 against drum 30.

In the device shown in Fig. 3, during the printing of the Y, M and C dyes, platen drum 30 rotates counter-clockwise. In order to discharge the completely printed paper after printing, platen drum 30 should rotate somewhat additionally until the holder 33 reaches the entrance of discharge port OO. Then, platen drum 30 rotates clockwise, the other arm 34b of bracket 34 pushes the other arm 33b of holder 33, and holder 33 is detached from platen drum 30. Accordingly, the forward tip of the completely printed paper is released, thereby

discharging the print-completed paper. At this time, the thermal print head (not shown) should press the printed paper to create a frictional force between the paper, the ribbon dye, and the platen drum.

Fig. 4A illustrates the conventional structure of a cassette for the ink bearing ribbon shown in Fig. 4B, which has a consecutive series of patterns each containing the yellow (Y), magenta (M) and cyan (C) color dyes. Conventional video color printers such as represented by Figures 1, 2 and 3, first print yellow, next print magenta, and finally print cyan after conforming the position of the paper at an initial printing position for the previous color, in order to thereby complete printing of one multi-color picture.

The platen drum of conventional multi-color printing devices should rotate somewhat in order to discharge the paper after completion of the printing of one picture under a scheme in which the thermal print head presses the record paper and region C' of the ink ribbon. Consequently, region C' of the cyan dye C on the ribbon is wasted. That is, in addition to the actual ribbon region of the dyes required for printing of one picture, the additional ribbon region C' is then consumed by the frictional engagement during the paper discharge steps. Also, because the platen drum should rotate further by the length of ribbon region C', printing speed is slow. In short, the device of Fig. 3 wastes printing time and ribbon material.

Referring now to Fig. 5, a device constructed to address the deficiencies of convention printers is illustrated. This device has a paper holder with a mechanism assembly 100, a buffer 200, a controller 300 and a mechanism driver 400. Mechanism assembly 100 includes a paper sensor 101, a print head contact sensor 102, a thermal printing head 103 heated according to concentration and density of color of the picture to be printed, a flange 104 for driving a bracket (not shown), and a platen drum 105 for moving the paper in the printing processes.

The record paper sensor 101 senses whether paper has been introduced through a supply port (not shown). Head contact sensor 102 detects the distance between the platen drum and the thermal print head when the head is lifted away from the platen drum. Sensory signals from sensor 101 indicating whether paper has been inserted into the supply port, and from sensor 102 indicating the distance between the thermal print head and the surface of the platen drum, are transmitted to buffer 200.

The controller 300 receives video signals for printing of video images, and controls the mechanism assembly 100 according to the sensory signals. A counter of controller 300 counts line numbers, and thereby enables sensing of the distance by which the paper moves along the circumference of platen drum 105. In dependence upon control signals from the controller 300, mechanism driver 400 drives the mechanism assembly 100. Driver 400 has a platen drum motor 402 for driving platen drum 105, a solenoid 401 for driving

flange 104, and a head motor 403 for driving thermal print head 103.

Fig. 6 is a detailed drawing of a pair of brackets 61, 61' with paper holders 60 installed adjacent the opposite ends of platen drum 105 of Fig. 5. Left and right brackets 61, 61' that are connected to both opposite base ends 107 respectively, so as to rotate around an axle 62 formed in each bracket 61, 61'. Each bracket 61, 61' has first 61a, second 61b, and third arms 61c joined together in a unitary, monolithic structure. The first and second arms 61a, 61b of each bracket define a centrally disposed recess 67 having spaced-apart curved sides positioned to ride along corresponding circumferential grooves 66a in each axle 66 of platen drum 105. Each pivot 62 is received into a corresponding conforming aperture 62' in the corresponding base 107 of drum 105. Pivots 62 and pins 63, 64 project from bracket 61. Thus, a distal end flange 104 of a solenoid 410 (see Figs. 7B, 7G) may contact pins 63, 64 and thereby rotate bracket 61 around pivot 62. Springs 65 are installed between point 69 of one arm 61a of bracket 61 and aperture 69' in the bases 107 of drum 105 so as to individually impose restoring forces on arms 61a of brackets 61 and the opposite bases 107 of the platen drum, thus pulling the paper holder 60, 60' toward the circumferential surface 109 of the platen drum 105. Curved recess 67 formed into the surface of bracket 61, accommodates, and is guided by, a flanged circumferential recess 66a of a shaft 66 coaxially extending from axially opposite bases of platen drum 105 as paper holder 60, 60' is moved toward, or from, platen drum 105. During movement of bracket 61 about pivot 62, a curved centerline of recess 67 travels along the axis "A" of axle 66 as the opposite curved surfaces of recess 67 ride along recess 66a. In one design, the curved sides of recess 67 define arcs of different radii having centers substantially coincidental with pivot 62, and paper holders 60, 60' define an arc having a center substantially coincidental with pivot 62 and a radius greater than the different radii defined by the curved sides of recess 67, as paper holders 60a, 60a' travel from a first orientation (see, *e.g.*, Figure 7A) where paper holders 60a, 60a' engage the circumferential surface 109, and around pivot 62 relative to opposite bases 107, to a second orientation (see, *e.g.*, Figure 7B) where paper holders 60a, 60a' are spaced apart from the circumferential surface 109.

Fig. 6B illustrates a thermal print head 103 with a pair of spaced-apart brackets 108 holding a shaft supporting a pair of rollers 72.

The operation of one embodiment of the present invention can be described with reference to Figs. 7A through 7H.

In Fig. 7A, if sensor 101 detects the presence of paper 70 (*i.e.*, the leading edge of a cut-sheet of paper 70) at a supply port SS at the leading edge of paper holder 60, controller 300 drives solenoid 401. Then, as is shown in Fig. 7B, flange 104 of the solenoid pushes each pin 64 (*n.b.*, only one base 107 of drum 105, and

thus only one bracket 61 is shown) in the direction of arrow "B" so that bracket 61 rotates around axle 62 in a counter-clockwise direction along the curved recess 67. As is shown in Fig. 7B, paper holder 60 is then forced away from the circumferential surface 107 of platen drum 105 to be spaced apart from the circumferential surface 107 of the platen drum 105 while a leading edge of a sheet of paper 70 is inserted between the paper holder 60 and circumferential surface 107 of drum 105.

Referring again to Fig. 7B, bracket 61 is rotated in a clockwise direction while being guided along the curved slides of recess 67 by the restoration force of spring 65, and returned to its original position, when an electric current through solenoid 401 is interrupted by a control signal from controller 300. Accordingly, the leading edge of paper 70 is fixed between paper holder 60 and the platen drum 105, as is shown in Fig. 7C (and as is also shown in Figures 7D, 7E and 7F).

Thus, drum 105 is rotated in a counter-clockwise direction by a platen drum motor 402 and simultaneously the counter of controller 300 counts printing lines, that is, each line of rotation by platen drum 105 which constitutes one of the 654 possible lines of rotation in single revolution by the circumference of drum 105.

Turning now to Fig. 7D, if a sheet of paper 70 is held by paper holder 60 while platen drum 105 is rotated through 400 lines and the line counter counts by 400 lines, the sheet of paper is delivered to position "D" at which position the line counter indicates 400 lines; rotation of drum 105 is then stopped and the thermal printing head 103 is lifted apart, and separated from, platen drum 105. Thereafter, platen drum 105 is rotated from the first position "D" in a counter-clockwise direction while the line counter counts through 64 lines until paper holder 60 arrives at point "E", at which position the counter indicates 64 lines, as is shown in Fig. 7E. The platen drum stops rotating, and printing head 103 presses multi-color ribbon 71 onto paper 70 under the force supplied by head motor 403 to provide a frictional force between surface 107 and paper 70. Thereafter, platen drum 105 is continuously rotated in a counter-clockwise direction and simultaneously the thermal printing head 103 is heated to sublimate a yellow color dye onto paper 70, with the result that part of the printing operation is performed as is shown in Fig. 7F. The printing operation for one color begins with the count made by the counter of controller 300, and is finished when that counter has counted 512 lines.

When the paper holder 60 is delivered through counter-clockwise rotation of platen drum 105, to point "F" after completion of the printing of the yellow color, as is shown in Fig. 7D, point "F" begins at 512 lines from the start of printing, platen drum 105 stops rotating and thermal printing head 103 is again lifted away from surface 107 separating paper holder 60 from platen drum 105. Platen drum 105 rotates further to deliver the heading edge of paper 70 to point "E" (of 142 lines, *i.e.*, rotation through 78 lines of the bottom margin of each sheet of paper 70 plus rotation through 64 lines of the

top margin of the sheet), and thereafter magenta color is printed onto paper 70 by repeating the same operation as is shown in Figs. 7E and 7F.

When the paper holder 60 arrives at point "E" after printing the yellow and magenta colors in the foregoing operations, platen drum 105 stops rotating, and head motor 403 causes head 103 to press ribbon 71 against paper 70. Then, head motor 403 stops and solenoid 401 drives flange 104 to engage projecting pin 63. Bracket 61, which is a unitary structure with projecting pin 63 and the paper holder 60, rotates around axle 62 in a counter-clockwise direction so as to move the paper holder 60 from point "E" in the direction of arrow "G". As is shown in Fig. 7G, the leading edge of the partially printed paper 70 (*i.e.*, only yellow and magenta colors have been printed onto paper 70 at this point) is released from paper holder 60 and is lifted by its intrinsic resilient force away from surface 107. At this time, if the electric current of solenoid 401 is interrupted, the restoring force of spring 65 returns the bracket to its original position and paper holder 60 again contacts surface 107 of platen drum 105 while the record paper is outside of paper holder 60, that is, with paper 70 being separated from surface 107 by holder 60 as is shown in Fig. 7H.

In Fig. 7H, the platen drum 105 continues to rotate for printing the last color, cyan, wherein the partially printed paper 70 upon which only yellow and magenta colors have been printed, is firmly held on the platen drum by the frictional force of roller 72 attached to the distal end of print head 103. A pair of discharging rollers 73 transmits the print-completed paper to a discharge tray immediately after completion of the printing of the cyan color component onto paper 70.

Figs. 8A and 8B illustrate flow charts of a micro-computer in the controller 300 interpolated into an embodiment of the present invention. After printing of yellow and magenta is completed in step 501, a control signal of logical "high" for driving head motor 403 is produced in order to lift the thermal print head away from the circumferential surface 107 of the platen drum 105. If the head 103 is lifted from the platen drum by a given distance, the control signal goes to a logical "low".

A drum motor control signal with a logical "high" state, for driving the platen drum 402, is produced to move the sheet of paper 70 to an initial printing position of cyan color in step 503. At step 502 the counter of the control part 300 counts the lines simultaneously with step 501. When the count number reaches 142, a control signal of logical "low" is generated by controller 300 and provided to the platen drum motor 402, thereby enabling motor 402 to stop platen drum 105 in step 505. Platen drum 105 and paper holder 60 are located at point "E" of Fig. 7E. Then, if the control signal of logic "high" is provided to head motor 403 in step 507, the head presses paper 70, and ribbon 71 onto the circumferential surface 107 of the platen drum 105 with a given pressure, the head being in a three-point contact position.

If the head 103 is in a three-point contact position in step 509, a control signal of logic "low" is provided to head motor 403, thereby stopping head 103 in step 511 and generating a control signal of logic "high" for solenoid 401 in step 513. Consequently, and as is shown in Fig. 7G, flange 104 rotates bracket 61 so that the paper holder is forced away from the platen drum and the leading edge of paper 70 is released.

If a given time is determined in step 515 to have passed after the control signal of logic "high" is applied to solenoid 401 in step 515, that control signal of logic "high" goes to logic "low" in step 517. Then the electric current through solenoid 401 is interrupted, thereby returning the flange to its original position, releasing the leading edge of paper 70 from platen drum 105 and causing the paper holder to ride upon the circumferential surface 107 of the platen drum 105.

The platen drum rotates counter-clockwise by a control signal of logic "high" applied to the drum motor in step 519, the thermal printing head is heated according to the concentration of the various color components in the picture to print in step 521. Simultaneously, the counter of controller 300 counts the printing lines by 512 lines in step 522. Thereafter, the drum motor and thermal heating of the head are stopped by the controller 300 in step 523. After completion of the printing of the last color, cyan, the print-completed paper is guided by a guide (not shown) to discharge rollers 73, and is discharged right after completion of printing of the last one of the colors, as is shown in Fig. 7H in step 525. Finally, the drum motor is stopped in step 527.

In conclusion, the paper holder increases the printing speed by preventing the platen drum from rotating unnecessarily and prevents waste of the ribbon by discharging the printing paper right after completion of the printing of all colors, without a need to either re-engage the colored ribbon with the print head to consume an additional length of the ribbon, or to reverse the direction of rotation of the platen drum. Advantageously, the platen drum while rotated in a single direction, transports the paper to be printed from a supply port, through a sequence of multi-colored printing, through disengagement with the paper holder, completion of multi-color printing and discharge without need from rotation in the opposite direction.

The embodiments disclosed in the foregoing paragraphs contemplate the use of sheets of paper with six hundred fifty-four possible lines of rotation, and thus the same number of possible lines of color printing. Actually, it is necessary to have a top and bottom margin for each sheet of paper; the embodiment has been disclosed with an exemplary top margin of sixty-four lines and a bottom margin of seventy-eight lines. Controller 300 may be set by a user to vary either, or both, the top and bottom margins of a sheet of paper. Additionally, controller 300 may be set by a user to vary the number of lines of printing, thereby enabling controller 300 to terminate printing in response to a different byline count by its internal counter and thus accommodate different

sizes of paper in response to the instructions of a user. Consequently, controller 300 may be readily set to accommodate a different size of paper; in one exemplar, sheets of paper with 607 lines of possible rotation were processed with the device and process disclosed.

While the present invention has been shown and described with reference to the preferred embodiment thereof, it will be understood by those skilled in the art that foregoing and other changes in form and detail may be made. For example, although it is desirable to have separate, spaced-apart paper holders 60a, 60a', it is possible to construct an embodiment as shown in Figure 6A, with a single bail extending between brackets 61, 61a, to serve as a paper holder 60a.

Claims

1. A printing device enabling printing of various colors in sequence, comprising:

an axle (66) coaxially positionable to extend axially outwardly from axially opposite bases of a platen drum providing a circumferential outer surface disposed between the opposite bases, said axle having circumferential grooves terminated by corresponding flanges;

a pair of brackets (61) each having first, second and third arms joined together in a unitary monolithic structure with said first and second arms defining a centrally disposed recess having spaced-apart curved sides positioned to ride along corresponding ones of said circumferential grooves, pivoting means (62) for pivotally connecting said second arms to the opposite bases of the platen drum, and means (60) for holding edges of sheets of paper against the circumferential outer surface (109) projecting axially inwardly from distal ends of said third arms across the circumferential outer surface; and

means (69) for biasing said bracket toward a first orientation relative to said pivot.

2. The device of claim 1, characterized by said bracket further comprises means (69) located at a position approximately diametrically opposite said axle (66) from said pivot means (62), for coupling said biasing means (65) to said bracket (61).

3. The device of claim 1 or 2, further comprised of:

means for engaging one of said first and second arms while in a first operational mode, and for causing rotation of said brackets (61, 61') from said first orientation where said holding means (60, 60') engages the circumferential surface (109), and around said pivoting means

(62) relative to said opposite bases, to a second orientation where said holding means is spaced apart from said circumferential surface.

4. The device of one of claims 1 to 3, characterized in that said curved sides define arcs of different radii having centers substantially coincidental with said pivoting means (62,62').

5. The device of claim 4, characterized in that said holding means (60,60') defines an arc having a center substantially coincidental with said pivoting means and a radius greater than said different radii, as said holding means travels from said first orientation where said holding means (60,60') engages the circumferential surface (109), and around said pivoting means (62,62') relative to said opposite bases, to a second orientation where said holding means is spaced apart from said circumferential surface.

6. The device of one of claims 1 to 4, characterized in that said holding means (60,62') are spaced apart from said pivoting means (62,62'), and positioned to travel along an arc spaced-apart from said pivoting means from a first position engaging edges of the circumferential outer surface to a second position spaced-apart from the circumferential surface.

7. The device of at least one of claims 1 to 6, characterized in that said holding means comprises a projection forming a distal terminal end of said third arm (61c) of each said brackets (61).

Patentansprüche

1. Druckvorrichtung, die das Drucken verschiedener Farben in Folge ermöglicht, umfassend:

eine Achse (66), die koaxial positionierbar ist, um sich axial nach außen von axial gegenüberliegenden Böden einer Druckwalze aus zu erstrecken, die eine zwischen den gegenüberliegenden Böden angeordnete äußere Umfangsoberfläche bereitstellt, wobei die Achse durch entsprechende Flansche abgeschlossene Umfangsrillen aufweist;

ein Paar Gabeln (61) mit je einem ersten, zweiten und dritten Arm, die in einer monolithischen Einheitsstruktur miteinander verbunden sind, wobei der erste und zweite Arm eine zentral angeordnete Vertiefung mit beabstandeten gekrümmten Seiten definieren, die positioniert sind, längs entsprechender der Umfangsrillen zu fahren, eine Drehzapfeneinrichtung (62) zum schwenkbaren Verbinden der zweiten Arme mit den gegenüberliegenden Böden der Druckwalze, eine Einrichtung (60) zum Halten der Kanten von Papierblättern gegen die

äußere Umfangsoberfläche (109), die von entfernten Enden der dritten Arme quer über die äußere Umfangsoberfläche axial nach innen vorspringt, und eine Einrichtung (65) zum Vorspannen der Gabel in Richtung auf eine erste Ausrichtung relativ zu dem Drehzapfen.

2. Vorrichtung nach Anspruch 1, dadurch gekennzeichnet, daß die Gabel weiter eine Einrichtung (69) umfaßt, die an einer Stelle ungefähr diametral gegenüber der Achse (66) der Drehzapfeneinrichtung (62) gelegen ist, zum Verbinden der Vorspannungseinrichtung (65) mit der Gabel (61).

3. Vorrichtung nach Anspruch 1 oder 2, weiter umfassend:

eine Einrichtung zum Einkuppeln eines der ersten und zweiten Arme während einer ersten Betriebsart und zum Bewirken einer Drehung der Gabeln (61, 61') von der ersten Ausrichtung, wo die Halteeinrichtung (60, 60') an der Umfangsoberfläche (109) anliegt, und um die Drehzapfeneinrichtung (62) herum relativ zu den gegenüberliegenden Böden zu einer zweiten Ausrichtung, wo die Halteeinrichtung von der Umfangsoberfläche beabstandet ist.

4. Vorrichtung nach einem der Ansprüche 1 bis 3, dadurch gekennzeichnet, daß die gekrümmten Seiten Bögen verschiedener Radien mit Mitten definieren, die im wesentlichen mit der Drehzapfeneinrichtung (62, 62') zusammenfallen.

5. Vorrichtung nach Anspruch 4, dadurch gekennzeichnet, daß die Halteeinrichtung (60, 60') einen Bogen mit einer Mitte, die im wesentlichen mit der Drehzapfeneinrichtung zusammenfällt, und einem Radius größer als die verschiedenen Radien definiert, wenn die Halteeinrichtung von der ersten Ausrichtung, wo die Halteeinrichtung die Umfangsoberfläche (109) berührt, und um die Drehzapfeneinrichtung (62, 62') herum relativ zu den gegenüberliegenden Böden zu einer zweiten Ausrichtung läuft, wo die Halteeinrichtung von der Umfangsoberfläche beabstandet ist.

6. Vorrichtung nach einem der Ansprüche 1 bis 4, dadurch gekennzeichnet, daß die Halteeinrichtungen (60, 60') von der Drehzapfeneinrichtung (62, 62') beabstandet und positioniert sind, längs eines von der Drehzapfeneinrichtung beabstandeten Bogens von einer ersten Position, die die Kanten der äußeren Umfangsoberfläche berührt, zu einer zweiten Position zu laufen, die von der Umfangsoberfläche beabstandet ist.

7. Vorrichtung nach einem der Ansprüche 1 bis 6, dadurch gekennzeichnet, daß die Halteeinrichtung

einen Vorsprung umfaßt, der ein entferntes Abschlußende des dritten Arms (61c) jeder der Gabeln (61) bildet.

5 Revendications

1. Dispositif d'impression permettant d'imprimer diverses couleurs à la suite, comprenant :

un axe (66) pouvant être positionné coaxialement pour s'étendre axialement vers l'extérieur à partir des surfaces de base axialement opposées d'un cylindre d'impression produisant une surface extérieure circonférentielle située entre les surfaces de base opposées, ledit axe ayant des rainures circonférentielles terminées par des collerettes correspondantes ;

deux supports (61) ayant chacun des premier, second et troisième bras réunis dans une structure unitaire monobloc dont lesdits premier et second bras définissent un évidement situé de façon centrale ayant des côtés écartés et recourbés positionnés de façon à chevaucher les côtés correspondants desdites rainures circonférentielles, un moyen de pivotement (62) pour relier de façon pivotante lesdits seconds bras aux surfaces de base opposées du cylindre d'impression, et un moyen (60) faisant saillie axialement vers l'intérieur à partir des extrémités distantes desdits troisièmes bras pour maintenir les bords des feuilles de papier contre la surface extérieure circonférentielle (109) sur toute la longueur de la surface extérieure circonférentielle ; et un moyen (69) pour incliner ledit support en direction d'une première orientation par rapport audit pivot.

2. Dispositif de la revendication 1, caractérisé par ledit support qui comprend de plus un moyen (69) situé à un emplacement approximativement diamétralement opposé audit axe (66) depuis ledit moyen de pivotement (62), pour coupler ledit moyen d'inclinaison (65) audit support (61).

3. Dispositif de la revendication 1 ou 2, comprenant de plus :

des moyens pour coopérer avec l'un desdits premiers et seconds bras pendant qu'ils sont dans un premier mode fonctionnel, et pour provoquer la rotation desdits supports (61, 61') à partir de ladite première orientation dans laquelle lesdits moyens de maintien (60, 60') coopèrent avec la surface circonférentielle (109), et autour dudit moyen de pivotement (62) par rapport auxdites surfaces de base opposées, jusqu'à une seconde orientation dans laquelle lesdits moyens de maintien sont écartés de ladite surface circonférentielle.

4. Dispositif de l'une des revendications 1 à 3, caractérisé en ce que lesdits côtés recourbés définissent des arcs de rayons différents ayant leurs centres qui coïncident sensiblement avec lesdits moyens de pivotement (62, 62'). 5
5. Dispositif de la revendication 4, caractérisé en ce que lesdits moyens de maintien (60, 60') définissent un arc ayant son centre qui coïncide sensiblement avec lesdits moyens de pivotement et un rayon supérieur auxdits rayons différents, lorsque lesdits moyens de maintien se déplacent depuis ladite première orientation dans laquelle lesdits moyens de maintien (60, 60') coopèrent avec la surface circonférentielle (109), et autour desdits moyens de pivotement (62, 62') par rapport auxdites surfaces de base opposées, jusqu'à une seconde orientation dans laquelle lesdits moyens de maintien sont écartés de ladite surface circonférentielle. 10
15
20
6. Dispositif de l'une des revendications 1 à 4, caractérisé en ce que lesdits moyens de maintien (60, 60') sont écartés desdits moyens de pivotement (62, 62'), et sont positionnés de façon à se déplacer le long d'un arc écarté desdits moyens de pivotement depuis une première position coopérant avec les bords de la surface extérieure circonférentielle jusqu'à une seconde position écartée de la surface circonférentielle. 25
30
7. Dispositif d'au moins l'une des revendications 1 à 6, caractérisé en ce que lesdits moyens de maintien comprennent une saillie formant une extrémité limitative distante dudit troisième bras (61c) de chacun desdits supports (61). 35
40
45
50
55

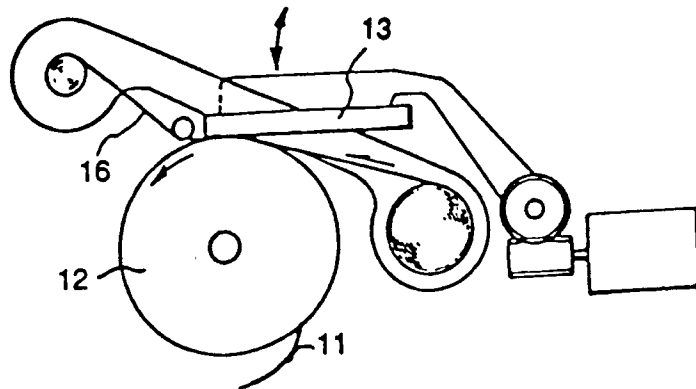

FIG. 1
(PRIOR ART)

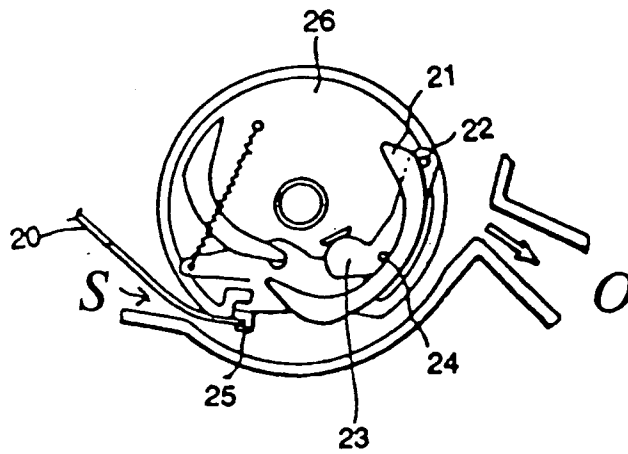

FIG. 2
(PRIOR ART)

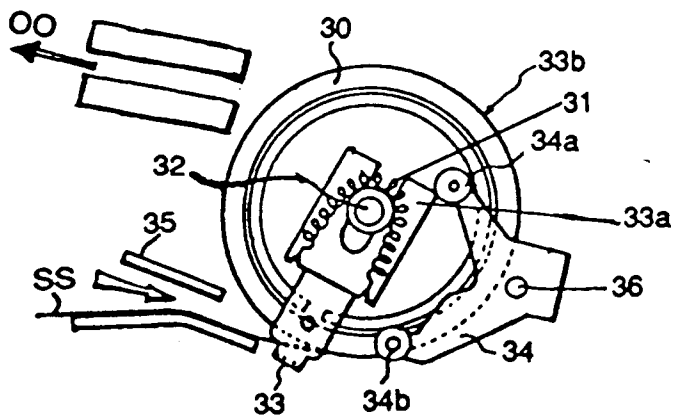

FIG. 3
(PRIOR ART)

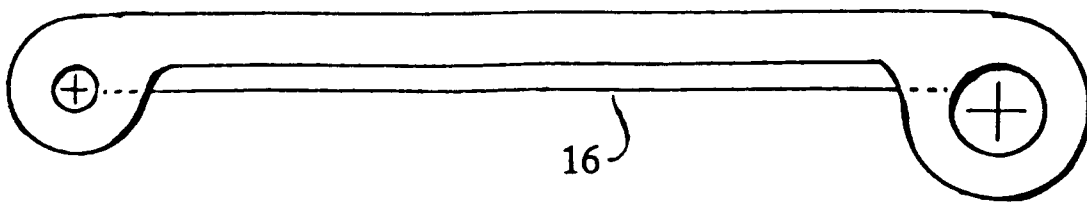

FIG. 4A
(Prior Art)

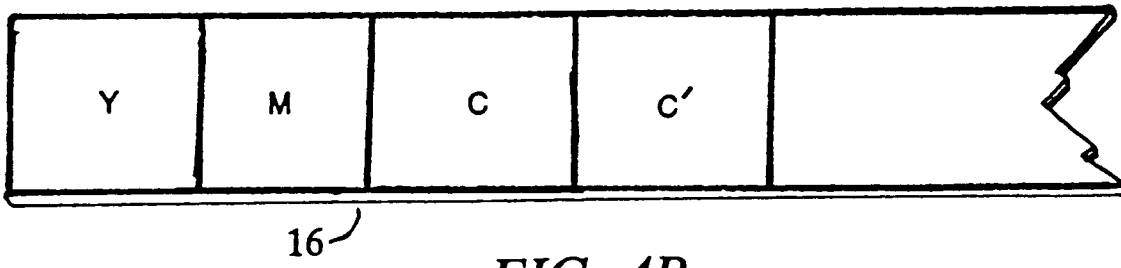
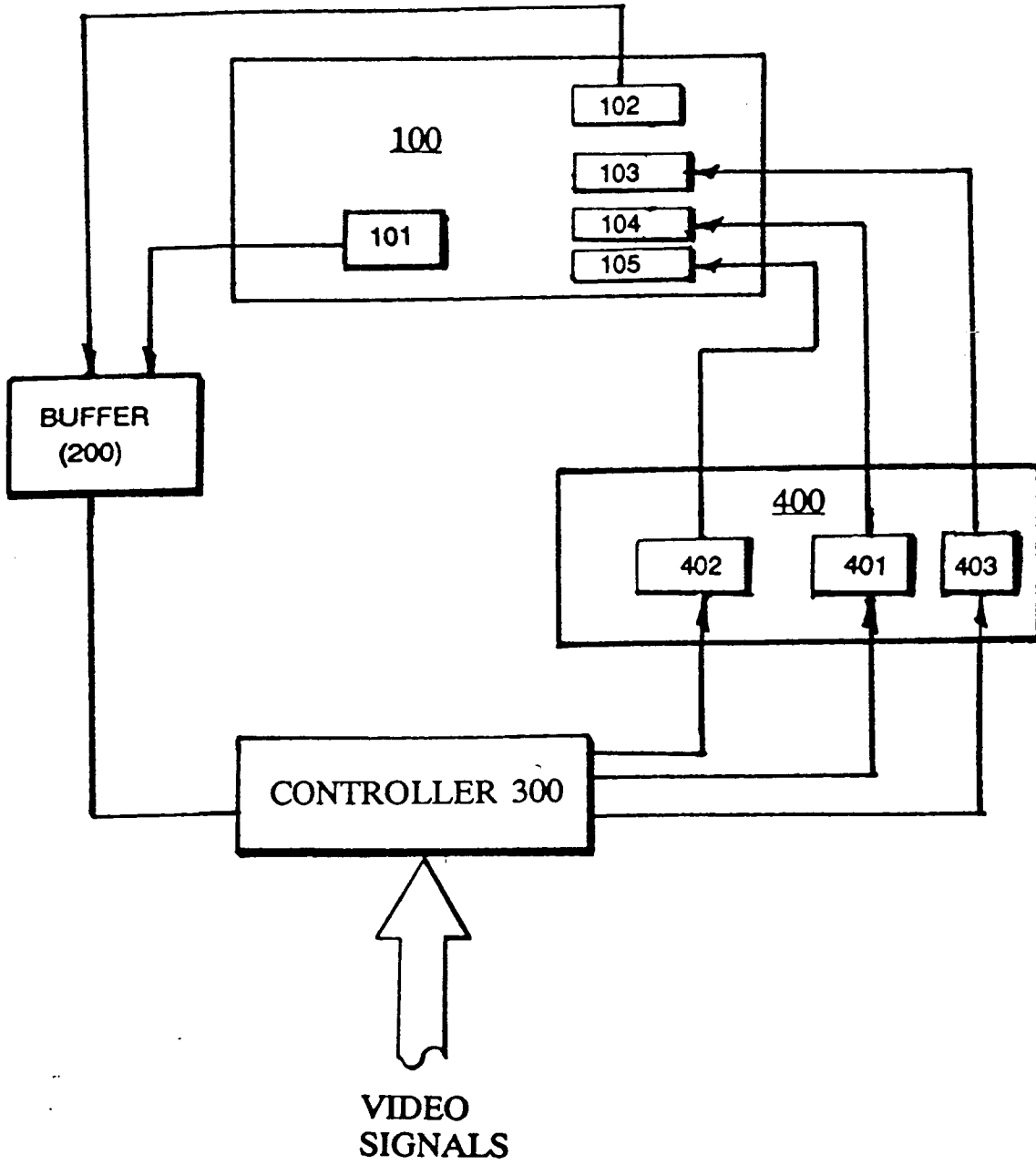

FIG. 4B
(Prior Art)

FIG. 5



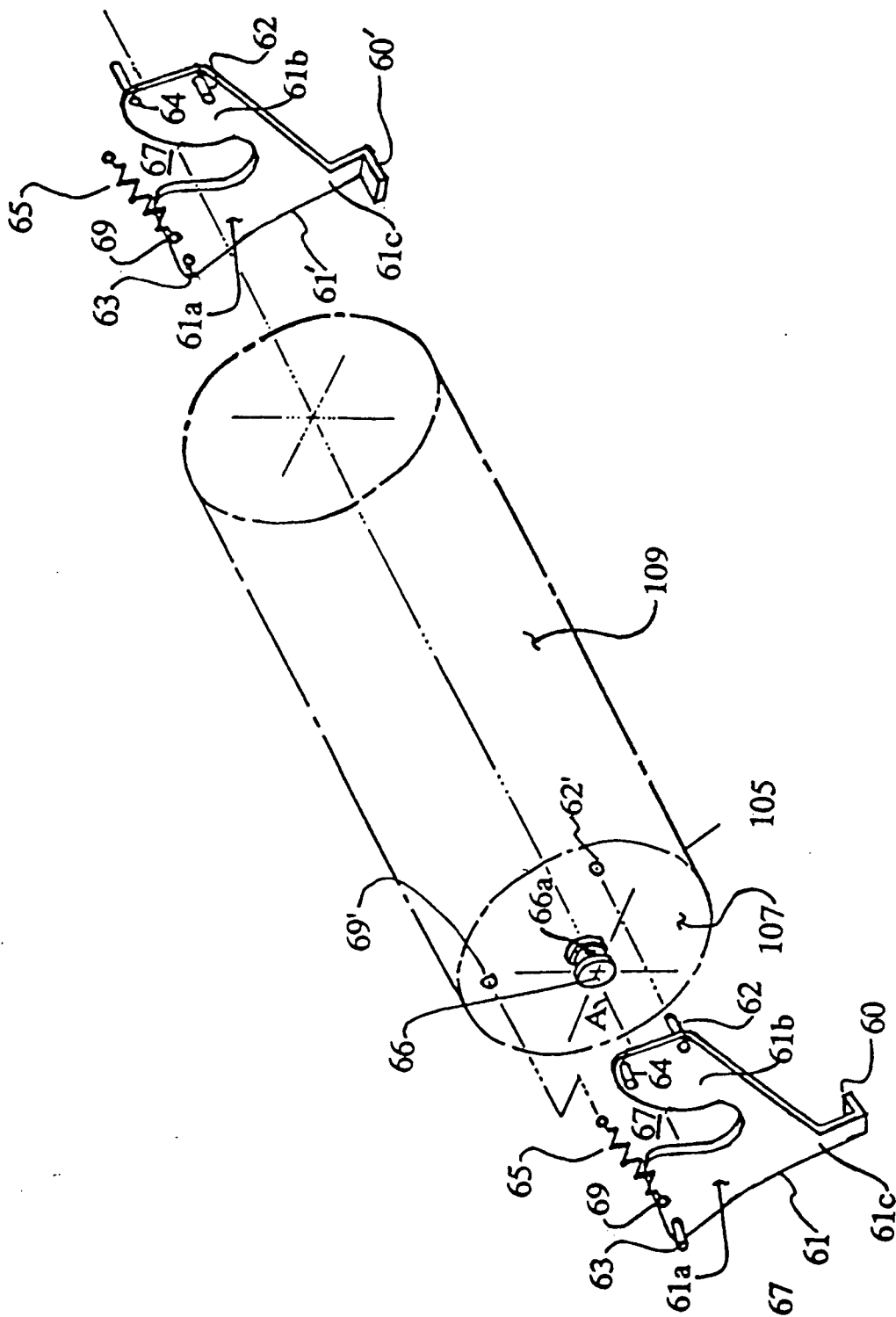

FIG. 6

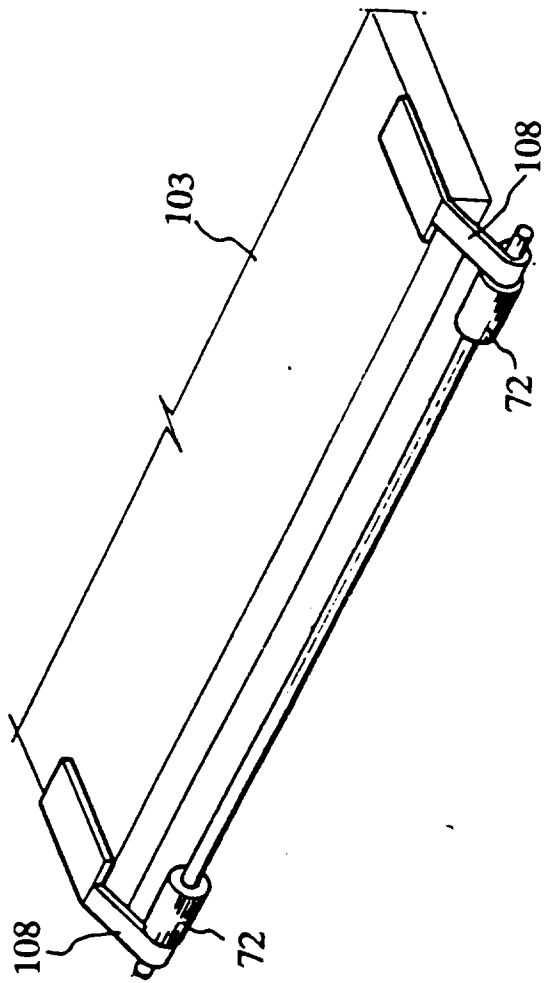

FIG. 6B

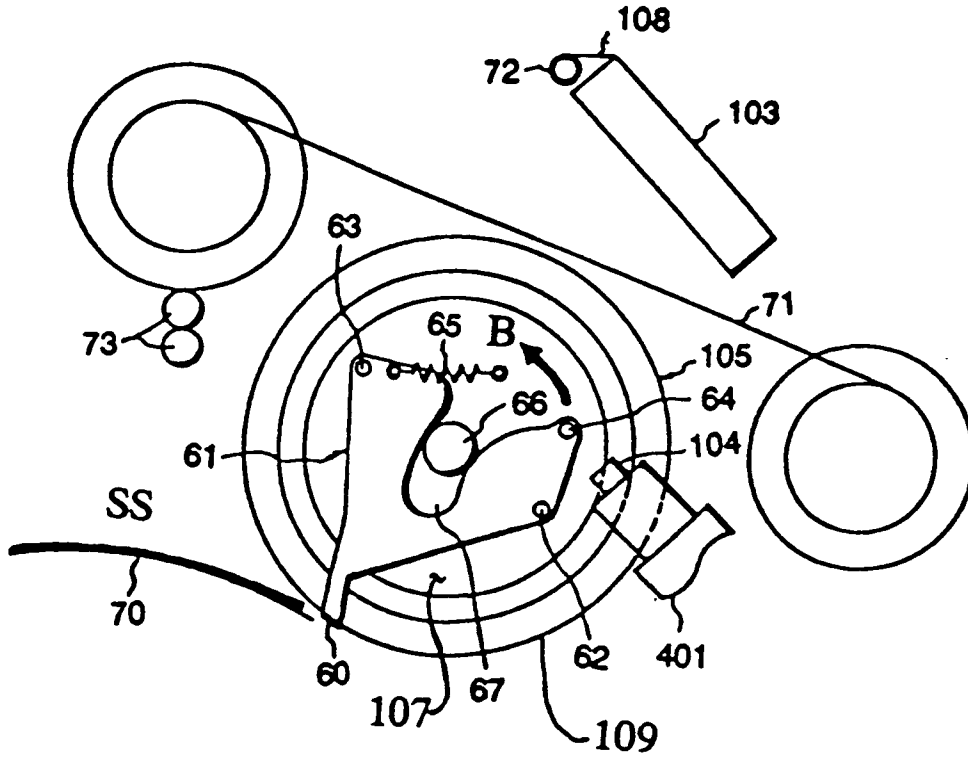

FIG. 7 A

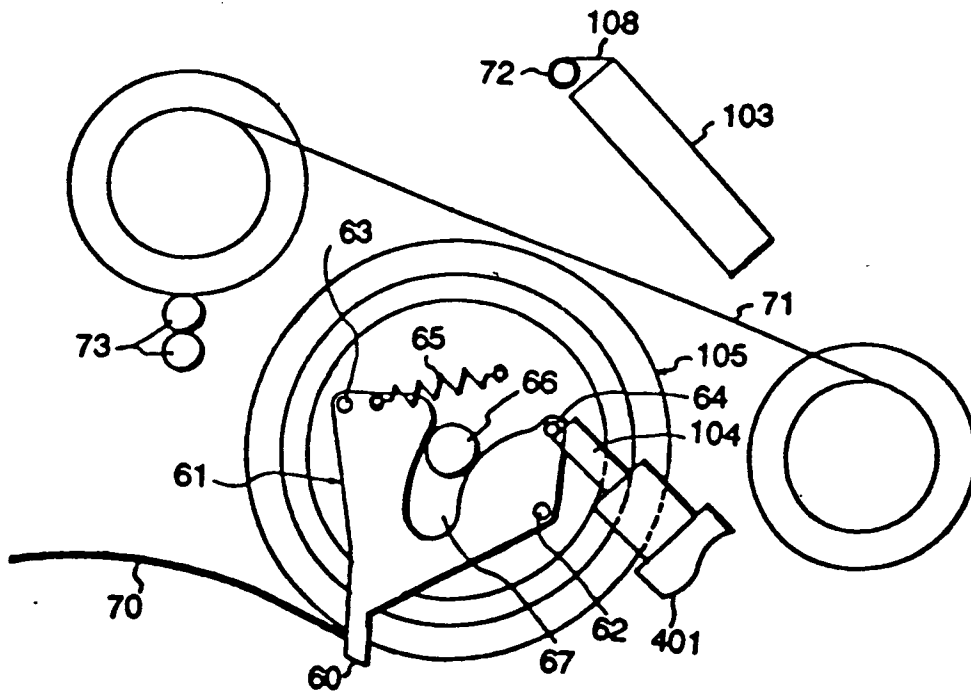

FIG. 7 B

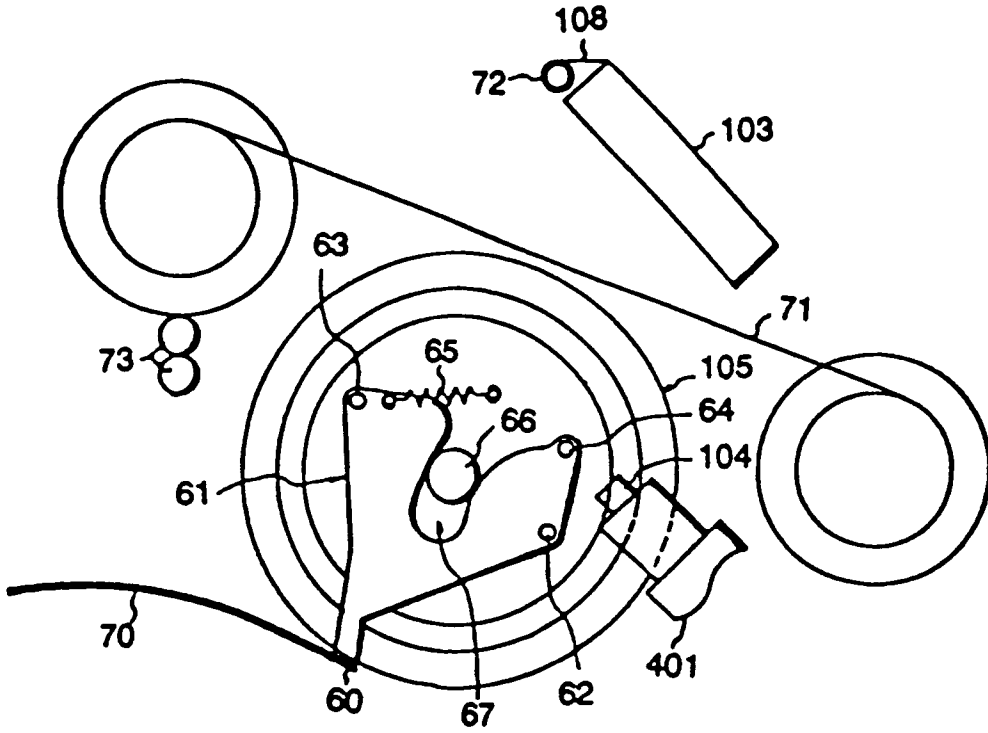

FIG. 7 C

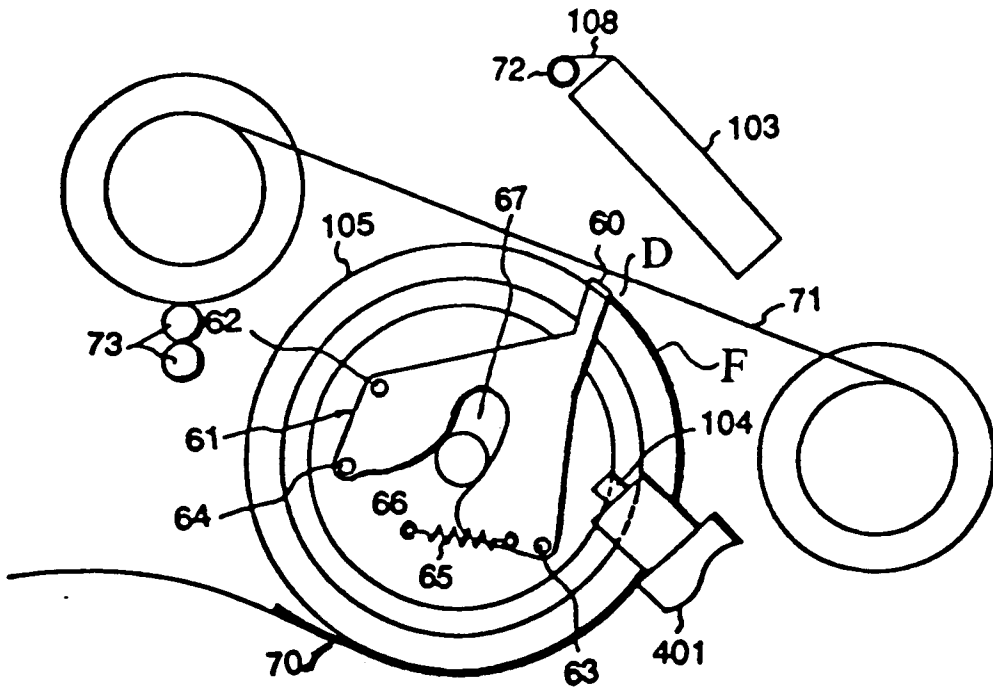

FIG. 7 D

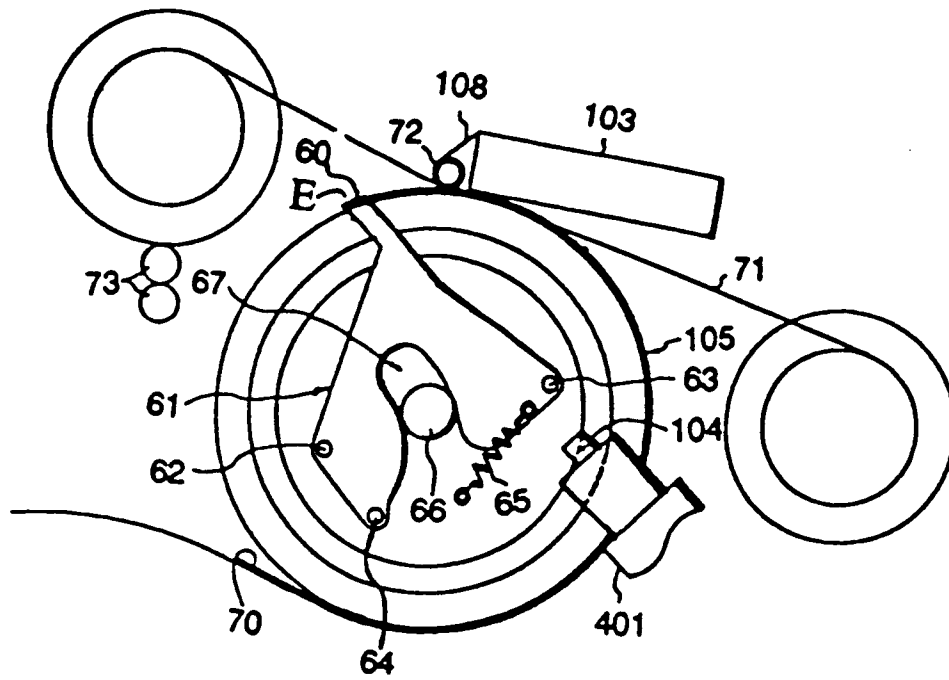

FIG. 7 E

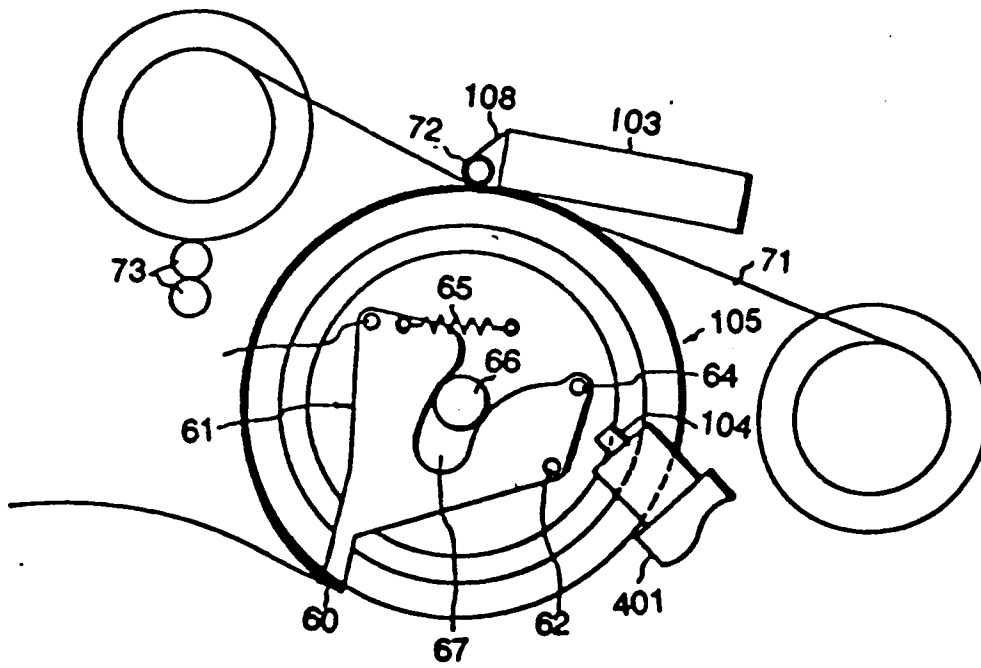

FIG. 7 F

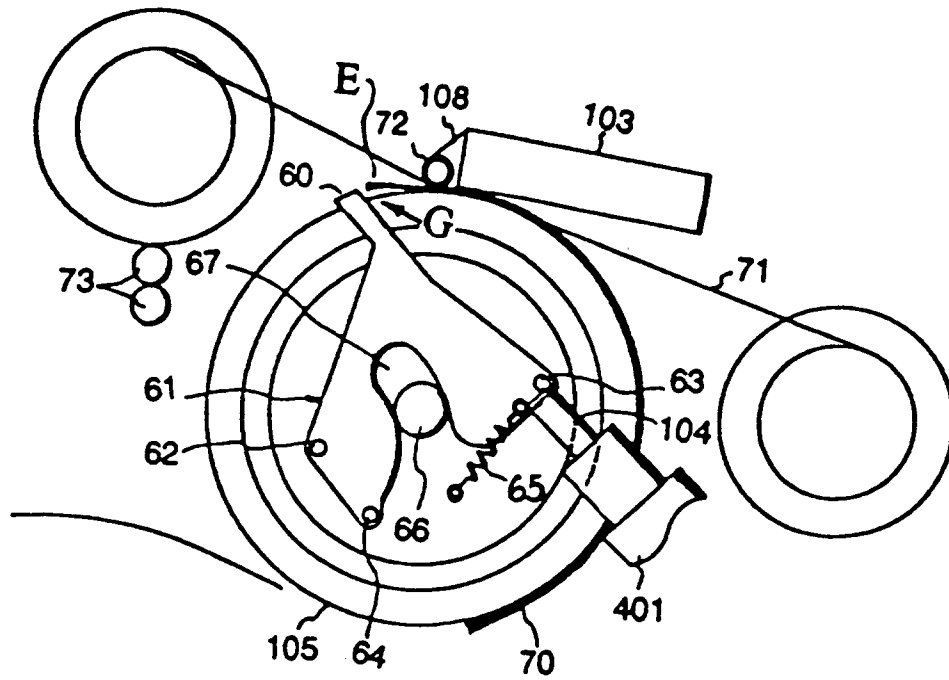

FIG. 7 G

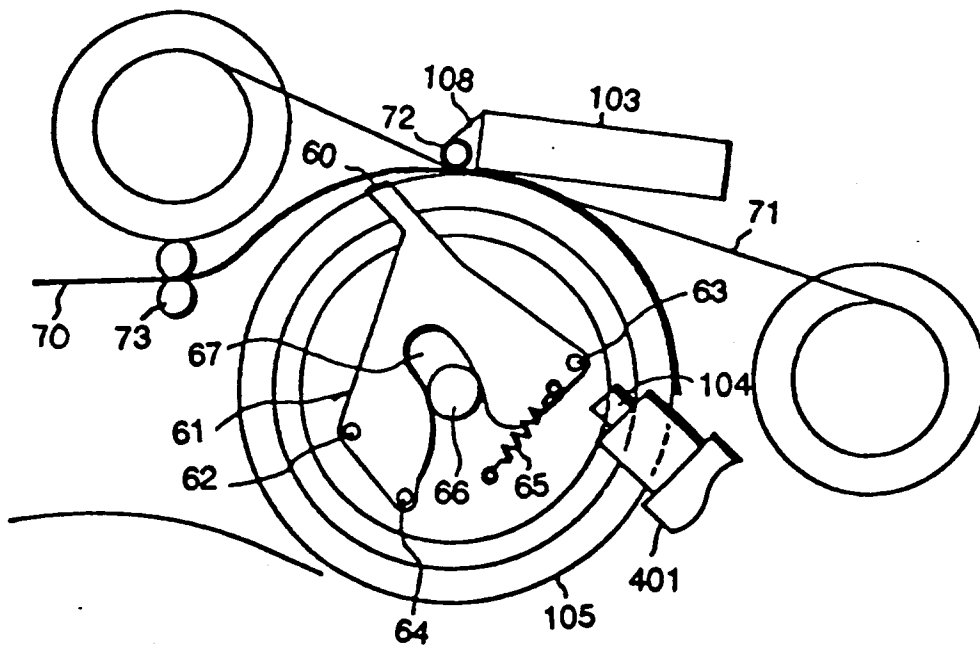

FIG. 7 H

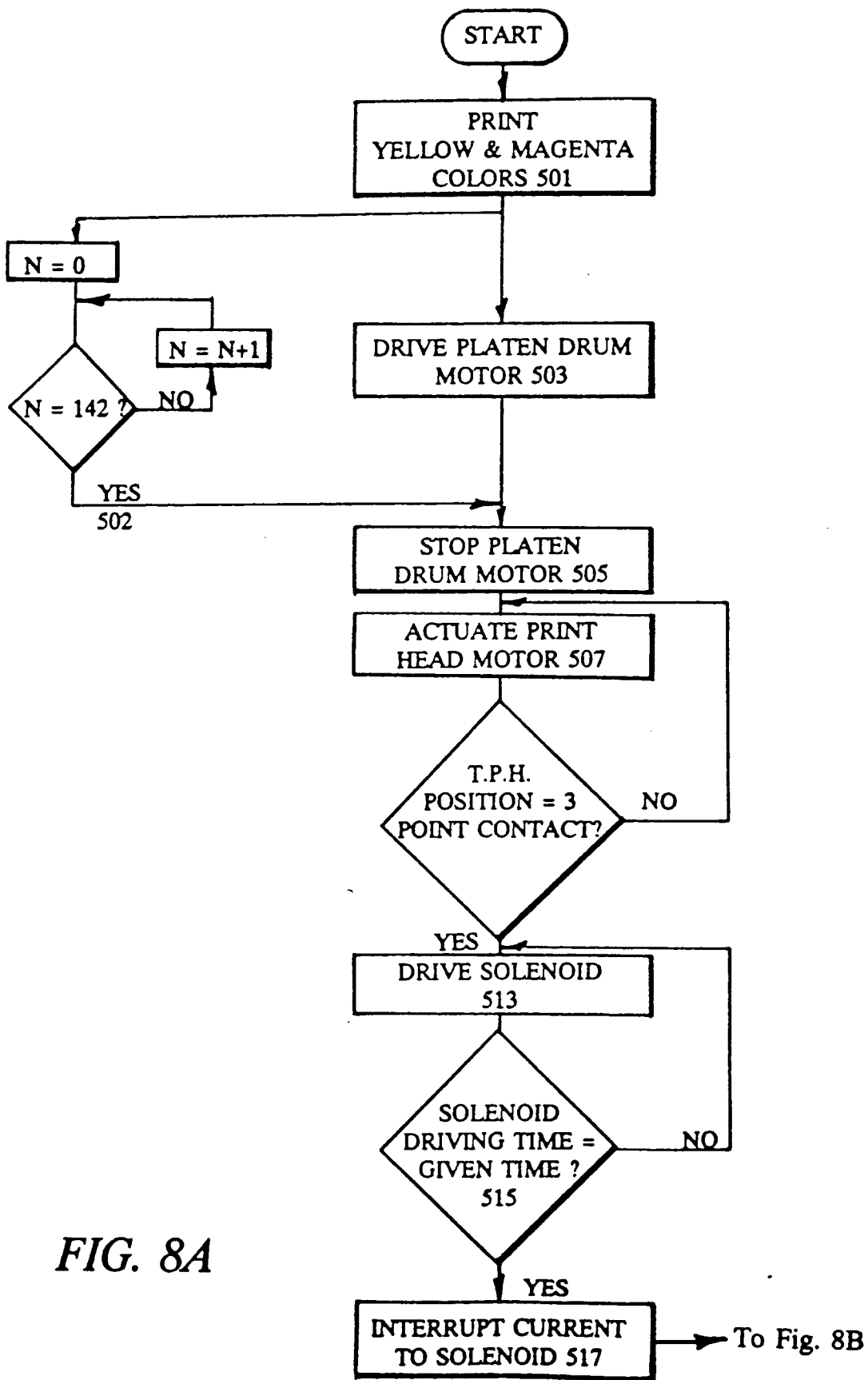

FIG. 8A

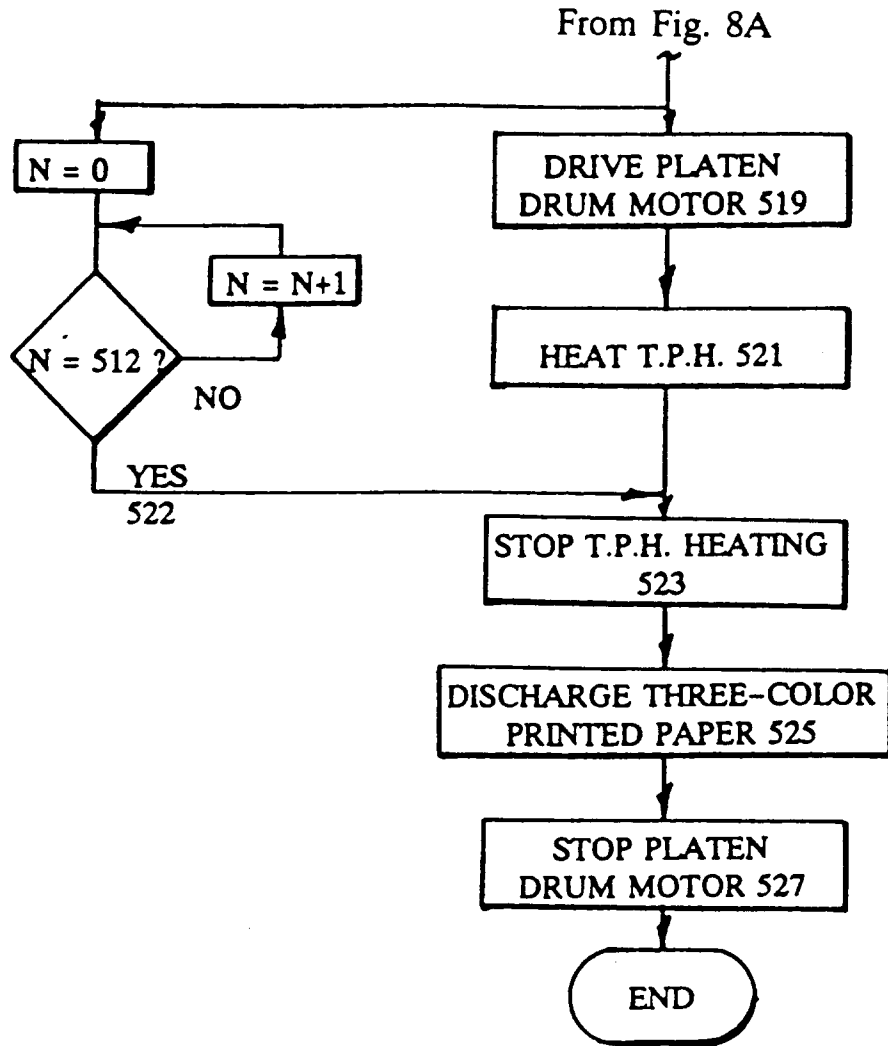

FIG. 8B