

(No Model.)

F. B. YERGER.
STONE POLISHING WHEEL.

No. 522,546.

Patented July 3, 1894.

Fig. 1.

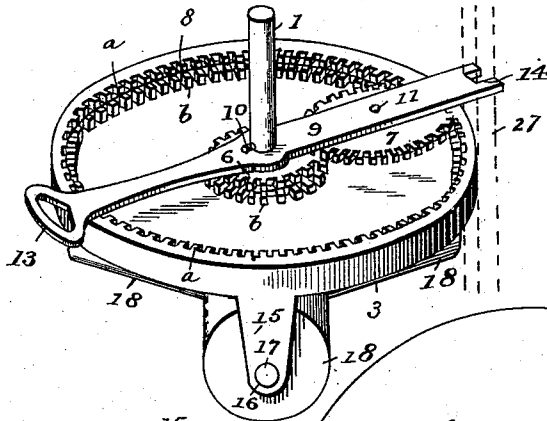

Fig. 4.

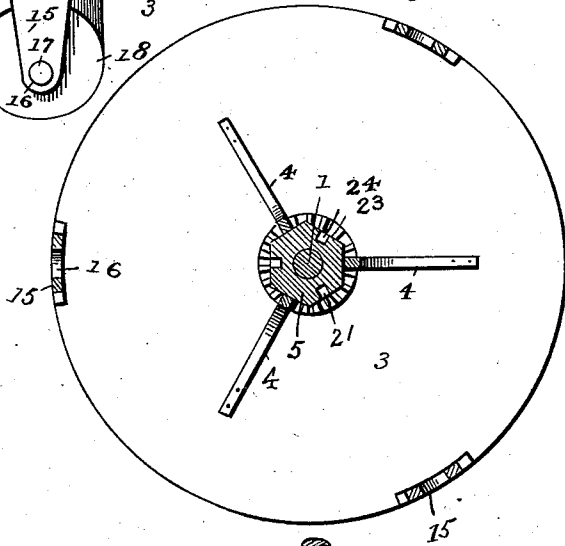

Fig. 2.

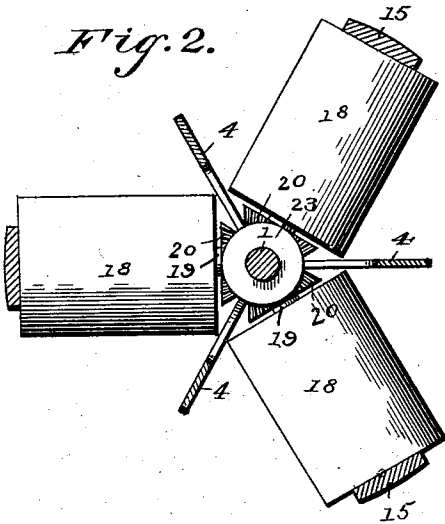

Fig. 3.

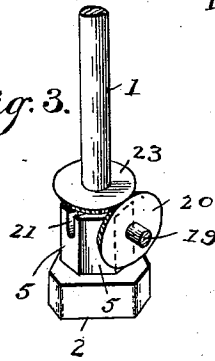
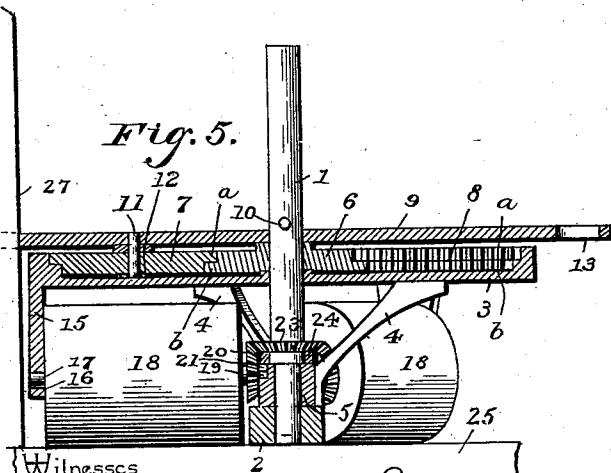

Fig. 5.



Inventor

Francis B. Yerger,

Witnesses
Julius Ulke, Jr. By his Attorneys.
A. R. Owens

C. A. Snow & Co.

UNITED STATES PATENT OFFICE.

FRANCIS B. YERGER, OF NIANTIC, RHODE ISLAND.

STONE-POLISHING WHEEL.

SPECIFICATION forming part of Letters Patent No. 522,546, dated July 3, 1894.

Application filed April 6, 1894. Serial No. 506,624. (No model.)

To all whom it may concern:

Be it known that I, FRANCIS B. YERGER, a citizen of the United States, residing at Niantic, in the county of Washington and State of Rhode Island, have invented a new and useful Stone-Polishing Wheel, of which the following is a specification.

My invention relates to an improved polishing wheel or head adapted for use in stone polishing, and to engage with the stone to be polished, and by such arrangement to effect the polishing operation; and the principal point of the invention lies in certain improved features of construction and combination and arrangement of parts, whereby the stone is polished with more efficacy than ordinarily.

In the accompanying drawings: Figure 1 represents a perspective view of my invention showing its use; Fig. 2, a horizontal section taken just below the gearing plate; Fig. 3, a view showing the drive-shaft and its gears for driving the rolls; Fig. 4, a bottom sectional view of the gearing plate or disk, and showing the attached arms; Fig. 5, a vertical longitudinal section.

The reference numeral 1 indicates the drive-shaft from which power for driving the rolls is derived, and which is connected at its upper end to any suitable source of power. The shaft 1 extends vertically and is provided at its lower extremity with the triangular block 2, which is adapted to bear on the stone, and which is thickened to compensate for the wearing which will attend its operations.

Mounted loosely upon the shaft 1 is the large disk 3, which is arranged horizontally and which is provided on its under side with the three downwardly and inwardly extending arms 4 which are rigidly secured to the disk, and are provided at their lower ends with the block 5. The block 5 is also rigidly secured to the arms and is preferably shaped hexagonally, the arms being secured to every alternate side thereof. This block is adapted to loosely embrace the shaft 1, and to bear at its lower end upon the block 2. By these means the disk 3 is supported upon the shaft 1, so as to be capable of free independent movement thereon, and this movement is imparted to it through the medium of the gears 6, 7, and 8. The gear 6 is rigidly secured to the

shaft, at a point directly above the disk 3, and lies flush therewith and meshes with the intermediate gear 7, imparting a rotary movement thereto.

Gear 7 is supported by the horizontal plate or bar 9, which is revolubly mounted at its middle upon the shaft 1, and projects across the disk and beyond its periphery on opposite sides thereof, a pin 10 being provided whereby the bar is held incapable of vertical movement. Formed on the under side of the bar 9, and projecting downwardly therefrom, is the stud 11, upon which the gear 7 is revolubly mounted, and a plate 12, is fixed to the lower end of the stud and operates to hold the gear in place. Thus the gear 7 is affixed to the plate or bar 9, and it is adapted to engage with the internal crown-gearing 8, formed integral with the outer periphery of the disk 3.

The teeth of gears 6, 7, and 8 may be of any form, but I prefer to make them with two faces *a* and *b*, axially coincident and provided each with a separate series of teeth. All of this may, however, be varied at will. By these means the movements of the shaft 1 are imparted to the disk 3, and the disk made to revolve thereon, as will be more fully described hereinafter. The left-hand or outer end of the bar 9 is formed with the hand-bail 13, by which the bar may be conveniently grasped, and by which the device may be steadied, while the remaining end of the bar is notched, at 14, to facilitate connecting the bar to a rigid post or standard 27, which may be affixed to any stationary object and by which the wheel is held stationary.

Rigidly secured to or formed integral with the periphery of the disk 3, and depending downwardly therefrom are the lugs or arms 15, which are three in number, and arranged equidistant from each other. Formed in the lower extremity of the arms 15 are the openings 16, in which the outer trunnions 17, of the rolls 18, are revolubly mounted. The rolls 18 are three in number, one for each of the arms 15, and are of a diameter equal to about the length of the arms 15, while the length of the rolls 18 is equal to the radius of the disk 3. The rolls 18 extend radially from the shaft 1 and are provided at their inner ends, or those adjacent to the shaft, with the trunnions 19, which have fixed thereto and lying flush

with the inner ends of the rolls, the beveled gear-wheels 20.

The trunnions 19 extend beyond the gears 20, and are journaled in the lower ends of the vertically-extending slots 21, of the block 5, which openings are formed in the sides of block 5 that are not occupied by the arms 4. Fixed to the shaft 1, at a point just above the block 5, is the pinion-gear 23, which is provided at its lower side with the flange or boss 24. This boss projects downwardly and engages the upper side of the block 5, whereby the trunnions 19, and consequently the rolls, are prevented from rising out of the slots 21. Gear 23 is adapted to mesh with the gears 20 of the rolls 18, and by this means the rolls are rotated in unison with the shaft 1.

From the foregoing it will be seen that as the shaft 1 revolves the disk 3 will be rotated in one direction, carrying with it the rolls 18 and causing them to move over the surface of the stone 25, polishing it in such movement. In addition to the revolution of disk 3 and rolls 18 as a unit, the rolls will each be given an independent rotary movement, owing to the operation of the gears 20 and 23, and this movement will be in a direction opposite to the direction taken by the disk 3. When the surface of the stone directly under the wheel has been sufficiently treated, the wheel may be moved along the stone, or the stone may be moved under the wheel, whichever may be the most convenient.

The wheel may be moved by changing the position of the bar 27, or by any other means, since all of this will be understood, and I will not describe it further.

Having described my invention, what I claim is—

1. A stone-polishing device, comprising the combination of a revolving shaft, a horizontal plate or disk loosely mounted on the shaft, gearing connecting the shaft and disk where-

by the latter is revolved in unison with the shaft, a box rigidly secured to the disk and loosely embracing the shaft below the disk, polishing rolls revolubly journaled in the box and disk, and on the under side thereof, and gearing connecting the shaft and rolls, whereby the rolls are revolved independently and in unison with the disk, substantially as described.

2. A stone-polishing device, comprising the combination of a revolving shaft, a horizontal disk loosely mounted thereon, a bar loosely mounted on the shaft and extending across the disk, and a gear fixed to the shaft just above the disk, and a second gear fixed to the bar and meshing with the gear on the shaft and with a cog-rim on the disk, whereby the disk is revolved, the bar being adapted to be secured to a stationary object, polishing rolls journaled in the disk and on the lower side thereof and adapted to move therewith, and gearing connecting the shaft and rolls, whereby they are driven independently in addition to their movements with the disk, substantially as described.

3. A stone polishing device comprising a vertical revoluble shaft, a disk loosely mounted thereon, a bar loosely mounted upon the shaft and directly above the disk, gearing connecting the shaft and disk, a box fixed to the under side of the disk and loosely embracing the shaft, a polishing roller journaled in said box and in the disk, and gearing connecting the shaft and roller, substantially as described.

In testimony that I claim the foregoing as my own I have hereto affixed my signature in the presence of two witnesses.

FRANCIS B. YERGER.

Witnesses:

BENJAMIN H. BARBER,
THEODORE E. BLACK.