

A. WORTHINGTON.
STEAM BOILER.

No. 424,528.

Patented Apr. 1, 1890.

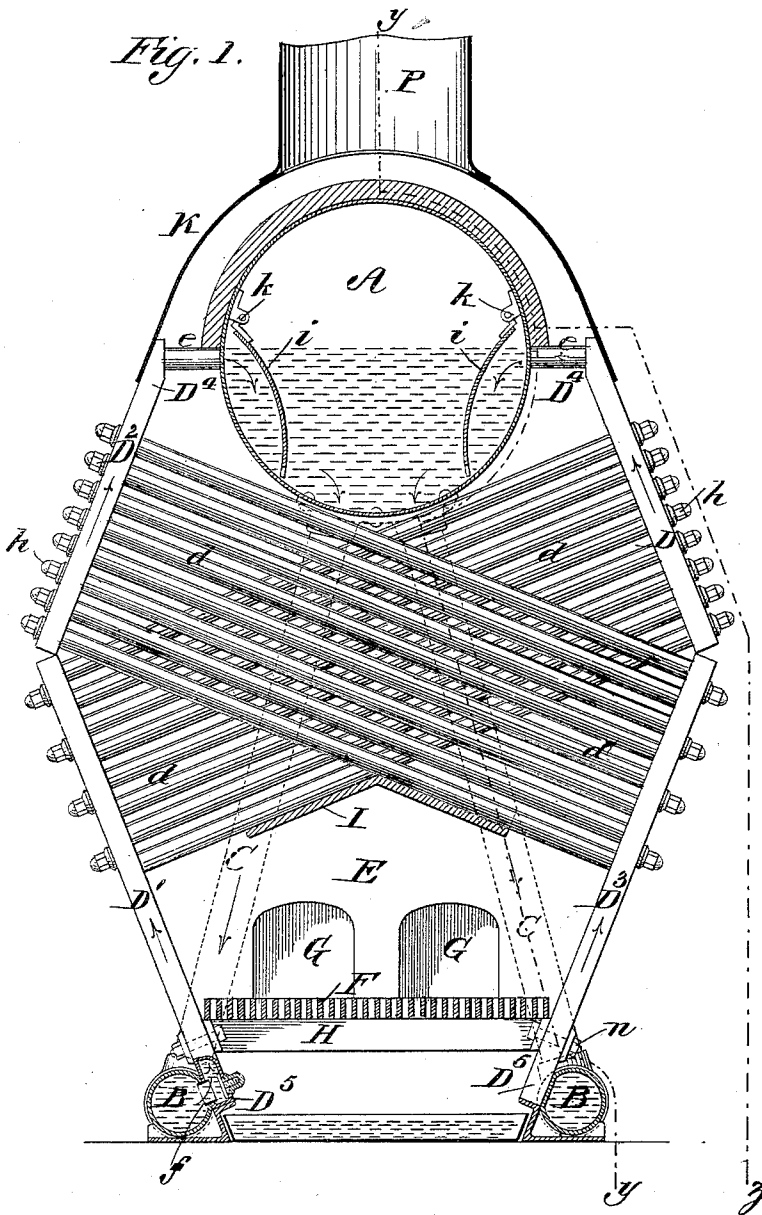

WITNESSES:

H. F. Parker.

Chas. Heimmann.

INVENTOR

Amasa Worthington

BY

Chas W. Forbes
ATTORNEY

A. WORTHINGTON.
STEAM BOILER.

No. 424,528.

Patented Apr. 1, 1890.

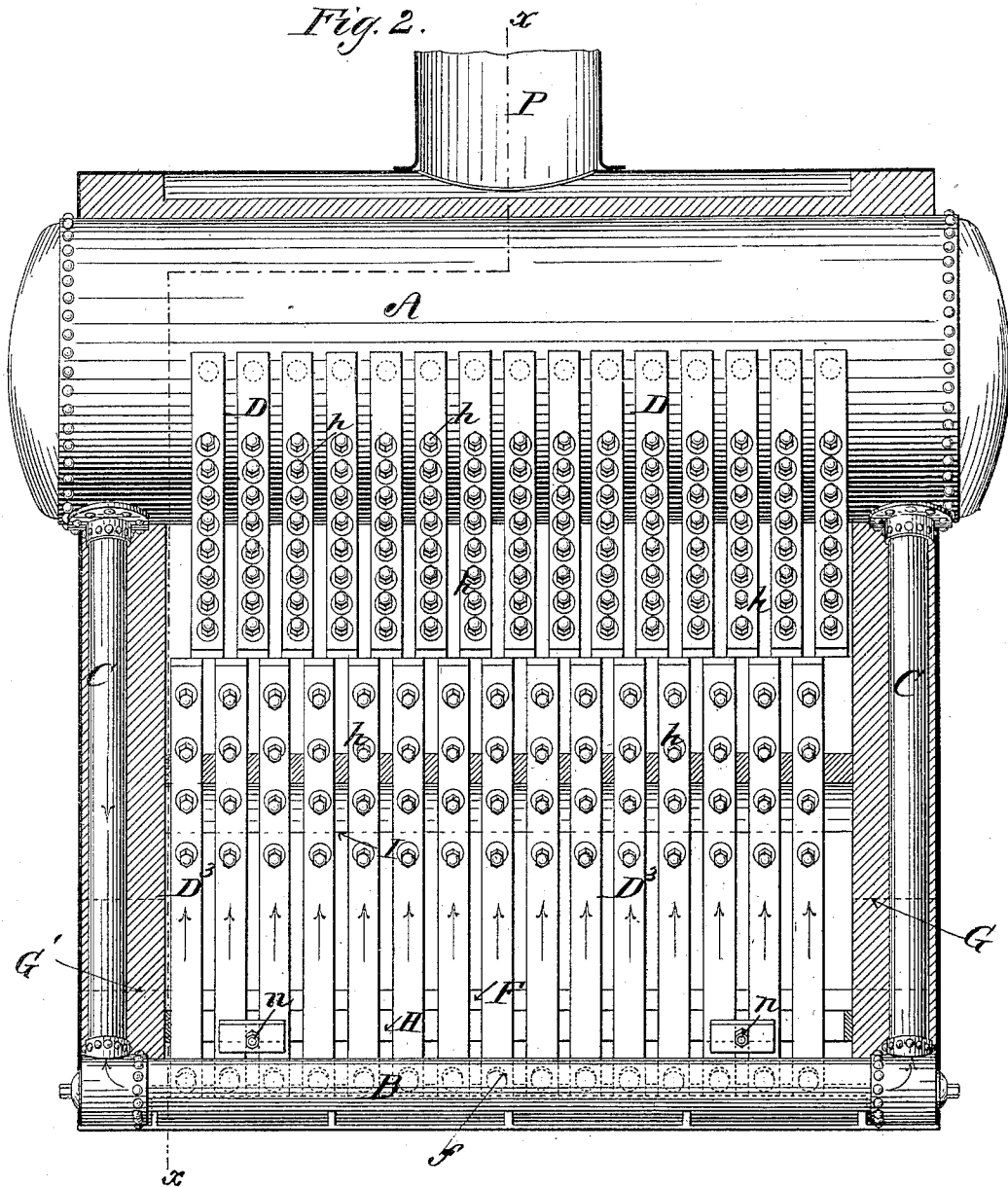

WITNESSES:
H. F. Parker,
Chas Hanimann

INVENTOR
Amasa Worthington
 BY
Chas W. Corbin
 ATTORNEY

UNITED STATES PATENT OFFICE.

AMASA WORTHINGTON, OF BROOKLYN, NEW YORK.

STEAM-BOILER.

SPECIFICATION forming part of Letters Patent No. 424,528, dated April 1, 1890.

Application filed July 11, 1889. Serial No. 317,225. (No model.)

To all whom it may concern:

Be it known that I, AMASA WORTHINGTON, a citizen of the United States, residing at the city of Brooklyn, county of Kings, and State of New York, have invented certain new and useful Improvements in Sectional Water-Tube Steam-Boilers, of which the following is a specification.

The object of my invention is to promote rapid and direct circulation, and thereby equalize the temperature of different parts of the boiler, to avoid conflicting currents in the water-circulation, and to obtain compactness of structure.

My invention consists in a structure composed of oppositely-inclined single vertical series of water-tubes which are interlocked, the lower ends connecting by means of headers with the water-drums and the upper ends connecting by means of separate headers with the steam drum or drums above the tubes.

My invention also consists in certain details of construction applicable to the present structure.

Referring to the accompanying drawings, in which like reference-letters indicate corresponding parts throughout, Figure 1 is a transverse section on the line $x x$, Fig. 2; Fig. 2, a side view of Fig. 1, partly in section on the line $y y$, Fig. 1, and partly viewed exterior to the line $y y$ and within the line $y z$. Fig. 3 is a transverse section of a modification, and Fig. 4 a partial side elevation of Fig. 3; Figs. 5 to 8, inclusive, are detail views hereinafter more fully referred to, showing a manner of constructing the headers.

In Figs. 1 and 2, A is the steam and water drum.

B B are the water-drums, and C C C C the water-legs or downflow-pipes—four in number—connecting the water-space of the steam and water drum at either end with the respective ends of the water-drums B B. The water-drums also serve as repositories for sediment, and may be provided with usual suitable blow-off cocks for the removal of such sediment.

D D' D² D³ are the water-tube headers, into which the ends of the water-tubes d are expanded. The headers D D' at opposite sides of the boiler, pertaining to the one inclination

of tubes, lie in common transverse planes, while the headers D² D³, pertaining to the oppositely-inclined tubes, lie in alternate or intervening transverse planes, so that the adjacent abutting ends of the headers break joints, as seen in Fig. 2. The ends D⁴ D⁴ of the headers D D² are connected independently with the steam-drum A at or near the water level by series of connecting-tubes e , while the ends D⁵ D⁵ of the headers D' D³ have independent communication with the water-drums B by means of connecting-nipples f .

The headers D D² are provided with hand-holes h , having cap-nuts, such as more fully shown in Figs. 5 and 6, and these are located opposite each tube to afford access for cleaning, while similar hand-holes are provided to the headers D' D³ at less frequent intervals sufficient for the discharge of material cleaned from the tubes d .

Opposite the entrance of the connecting-tubes e to the drum A and within the same are provided deflecting shields or partitions i , swinging on hinges at k . An opening is left above the shields i sufficient for the issue of steam to the steam-space of the drum, while the inclined and yielding surfaces of the shields which are freely suspended serve to direct the general current downward into the water-space, preventing any water that is entrained with the steam being thrown upward toward the point of delivery.

The interspaces between the headers which appear in Fig. 2 are filled with suitable fire-brick or other refractory filling, such as to form complete walls at the sides of the furnace and draft-passage above.

The fire-grate F and furnace E extend entire length of the boiler in the present illustration, the fire-doors G G' being located at one or both ends.

The construction of the furnace may be modified in various ways, such as may be found expedient in different sizes of the generator or location of the same.

The fire-grate is supported upon a frame H, bolted to the headers D' D³ by bolts n , or otherwise suitably secured in the cradle formed by the converging headers.

I is a reflecting or radiating crown provided to the furnace to intensify combustion, and also to delay the gases until perfect igni-

tion is effected. The upper portion of the structure is confined by the hood K, forming a draft-passage toward the smoke-flue P.

The headers represented in Figs. 1 and 2 are constructed as appears in horizontal cross-section in Fig. 5 or in vertical section in Fig. 6. The cap-nuts *n* fit upon the beveled seats of the apertures, being screwed to the shank of the yoke *p*.

Fig. 7 illustrates a double construction of the header, which is formed by collapsing a single tube into the desired form and uniting the intermediate portion by means of rivets. Fig. 8 illustrates a similar manner of forming any desired number of such headers by the uniting of corrugated sheets of metal M N by means of rivets. The latter construction composes a complete wall, and in this instance the fire-brick filling hereinbefore referred to between the headers may be dispensed with.

The essential feature of difference in the carrying out of my invention (illustrated in Figs. 3 and 4) consists in the substitution for the downflow water-legs C C of the upper tubes *d' d'* of each series, which tubes *d' d'* are connected directly to the lower portion of the water-space in the steam-drum, and act as downflow-pipes, equivalent in function to the pipes C C. The downward current is distributed over the lowermost ends of the remaining series of tubes *d d* within the headers D' D'. The drums B B in this instance, being located in a direct vertical line beneath a downward current in the headers D' D', accumulate the sediment which is thrown down or gravitates into them, and may be blown off from time to time, the circulation not, however, passing through the drums B B, as in the first instance described. The drums B B are connected by cross-tubes L, which serve as grate-supporters, and which virtually unite the drums B B into a single water-chamber. In other respects the form of the apparatus illustrated in Figs. 3 and 4 corresponds to that illustrated in Figs. 1 and 2, it being immaterial whether the headers be inclined or vertical.

The vertical headers in Figs. 3 and 4 are of peculiar construction, each consisting of a vertical central tube *r* and a series of oblique pockets *s s* at each side thereof, being composed of an integral piece. A double series of tubes are thereby expanded into the inclined apertures of the pockets communicating in common with the central tube *r*. This feature of construction of the headers I claim as a part of the subject-matter of a separate patent application to be filed.

It is to be remarked that the vertical headers are provided with flanges *u*, whereby their edges may be united to form a continuous wall, or whereby a suitable fire-brick filling may be sustained between them. Plates *v* are also provided in the construction of Figs. 3 and 4 to close the combustion-space.

In the operation of my invention the circulation occurs independently through the sev-

eral sections of the generator. The directions of the currents are opposite in their independent courses, thereby equalizing the absorption of caloric, and due to the peculiar arrangement of the tubes I obtain the maximum effect of the furnace before the heat has become reduced by a long passage.

By means of the divergent and convergent shape of the combustion-space represented in Fig. 1 I obtain an enlarged combustion-space above the grate in proportion to the grate-surface and a slow passage of the hot gases among the tubes where the volume of the chamber is greatest, the draft subsequently having an accelerated eduction as the gases are cooled and the space contracts.

I claim as my invention—

1. The combination, in a sectional steam-generator, of a steam chamber or chambers, a water chamber or chambers below the level thereof, interlocked series of oppositely-inclined water-tubes, and separate headers connecting the same at their upper and lower ends, respectively, with the said steam and water chambers.

2. The combination, in a sectional steam-generator, of an upper steam chamber or chambers, lower water-chambers parallel to said upper steam chamber or chambers, an interlocked assemblage of oppositely-inclined single vertical series of water-tubes, headers connecting the upper ends of each member of one or more of such series together and with the said steam chamber or chambers, headers connecting the lower ends of one or more of such series together and with the said lower water-chambers, and the downflow-pipes C, connecting the said upper steam chamber or chambers with the said lower water-chambers.

3. The combination, in a sectional steam-generator, of a longitudinal steam and water drum, parallel water-drums below the level of the same, oppositely-inclined single vertical series of water-tubes interlocking in successive vertical planes transverse to the said drums, and headers connecting the upper and lower ends of each such series independently and respectively with the said steam and water drum and the said water-drums.

4. The combination, in a sectional steam-generator, of a longitudinal steam and water drum above the furnace, parallel water-drums below the sides of the furnace, oppositely-inclined single vertical series of water-tubes interlocking in successive vertical planes transverse to the said drums, and headers connecting to the upper ends of the tubes extended in said vertical planes to connect with the sides of the steam and water drum, and headers connecting to the lower ends of the tubes extended in said vertical planes to form the side walls of the furnace and connect with the water-drums.

5. The combination, with series of water-tubes lying in vertical planes, of headers composed of vertically-corrugated sheets of metal united between each said vertical planes of

the series, in the form substantially as specified, having vertical water-channels and composing a continuous wall.

5 6. The combination, with the steam and water drum of a water-tube boiler, of the deflecting-plates suspended from hinges and located within the drum opposite the steam-induction tubes, said plate being inclined toward

the bottom of the drum and having a steam-passage above the portion which is inclined, 10 for the purposes set forth.

AMASA WORTHINGTON.

Witnesses:

H. F. PARKER,
CHAS. HANIMANN.