

J. W. ELLIOT.

Track Clearer.

No. 108,894.

Patented Nov. 1, 1870.

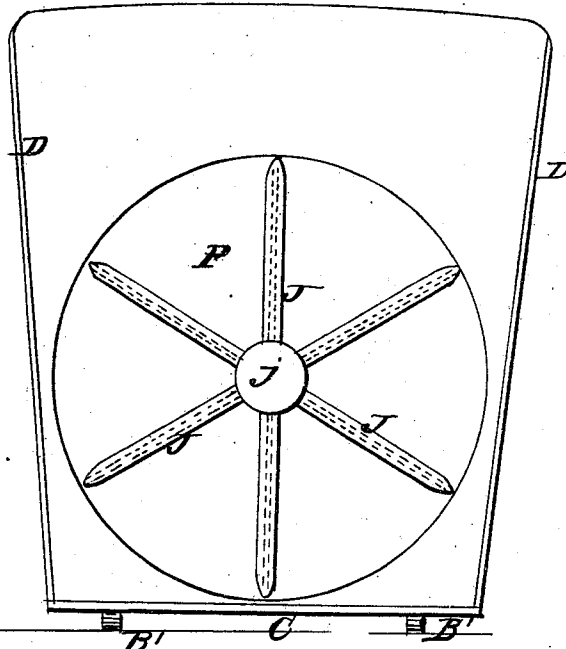
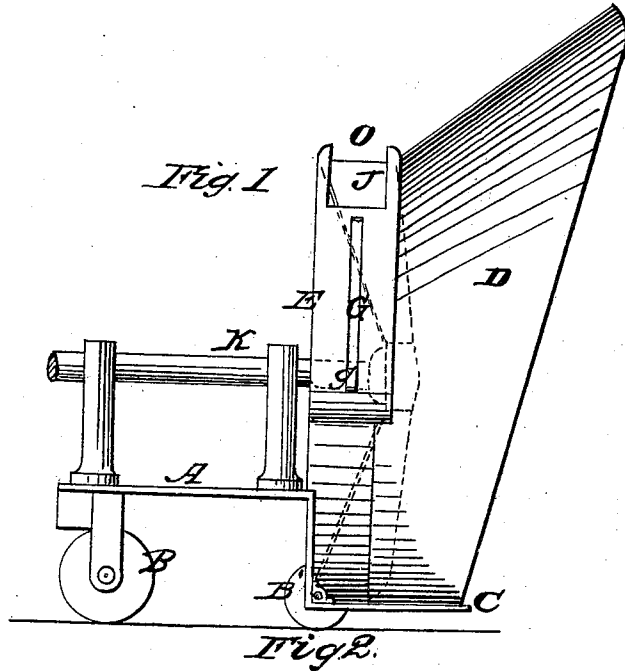

Witnesses
R. Hauptmann
J. C. Campbell

Inventor
J. W. Elliot
Wm. French Hamner

J. W. ELLIOT.

Track Clearer.

No. 108,894.

Patented Nov. 1, 1870.

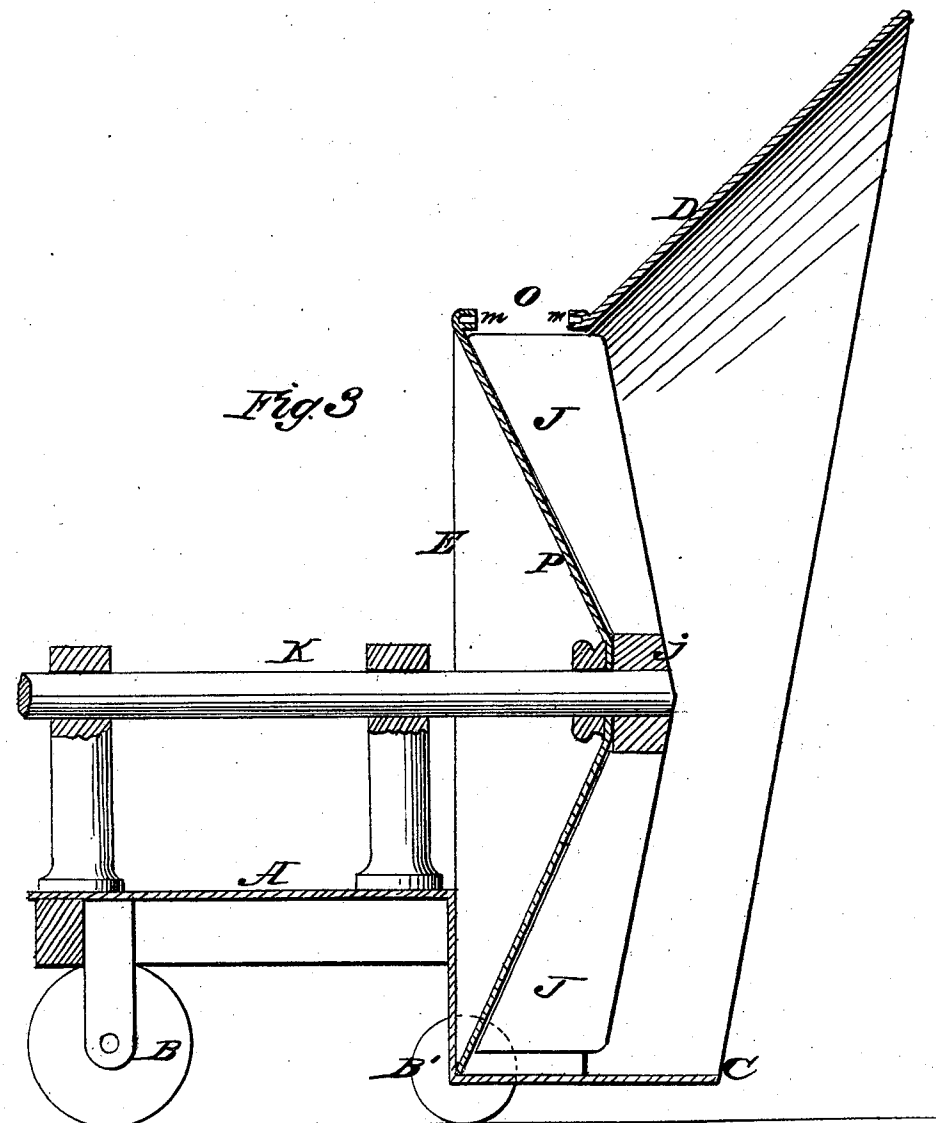

Witnesses.
R. S. Campbell
J. W. Campbell

Inventor
J. W. Elliot
Wm. Henschel Lawrence

United States Patent Office.

JOHN WHEELER ELLIOT, OF TORONTO, CANADA.

Letters Patent No. 108,894, dated November 1, 1870.

IMPROVEMENT IN RAILWAY SNOW-SHOVELS.

The Schedule referred to in these Letters Patent and making part of the same.

To all whom it may concern :

Be it known that I, JOHN WHEELER ELLIOT, formerly of Leicester, Massachusetts, but now of Toronto, in the Dominion of Canada, have invented a new and improved Railroad Snow-Shovel; and I do hereby declare that the following is a full, clear, and exact description thereof, reference being had to the accompanying drawing making part of this specification, in which—

Figure 1, plate 1, is an elevation of one side of the improved snow-shovel.

Figure 2, plate 1, is a front view of the same.

Figure 3, plate 2, is a vertical section taken longitudinally through the center of the shovel and its truck.

Similar letters of reference indicate corresponding parts in the several figures.

The object of this invention is to apply in front of a locomotive engine a contrivance which will effectually clear snow from the track as the locomotive proceeds thereon, and discharge it laterally from the upper side of the cylindrical portion of the machine.

The nature of my invention consists—

First, in combining, with a broad flaring shovel or scoop, having a concavo-convex back, a revolving discharging device, composed of radial blades, which will rapidly expel the snow gathered into the shovel through an opening made through the upper side of the same, as will be hereinafter explained.

Second, in providing the opening, through which the snow is discharged from the shovel, with movable covers, for the purpose of causing the discharge of the snow from whichever side of the shovel it may be desired, as will be hereinafter explained.

To enable others skilled in the art to understand my invention, I will explain its construction and operation.

In the accompanying drawing—

A represents a truck, which is mounted upon wheels B B', and made of such size and strength as to adapt it for receiving and supporting the shovel or scoop, the revolving discharger, and the boiler and engine for operating the latter independently of the power which is applied to propel the locomotive.

The front part of this truck has a depressed horizontal shovel, C, which is somewhat wider than the width of the track, and which is arranged very near the tops of the rails.

Upon this shovel O is constructed a flaring scoop or gatherer, D, which may be of the form represented in the drawing, and which may be made of boiler-iron, strongly braced, to sustain the pressure of snow

which is brought against it while clearing the track. This scoop has upwardly and outwardly a flaring top, and it terminates behind in a cylindrical portion E, having a back, which presents in front a conical or convex surface.

Within the cylindrical portion E, and keyed upon the front end of a longitudinal shaft, K, is a revolving discharger, which is composed of blades J J, radiating from a central hub, *j*, as shown in the drawing.

The blades J of the discharger taper from their outer ends to the hub *j*, and their rear edges sweep close to the convex back P; thus they present broadest surfaces nearest the circumference of the cylindrical portion E.

Through the upper portion of the cylinder E a transversely oblong opening, O, is made, which is provided on each side of the central line with a slide, G, which can be moved by the piece *g*.

By means of these slides one-half of opening O on the right-hand side can be closed for discharging the snow laterally to the left-hand side of the track, or the opposite half of the opening O can be made for discharging the snow on the right-hand side of the track.

The slides are held in place in the grooves *m m*, formed into the longitudinal edges of the cylinder E, bounding the opening O.

The shaft K is supported by suitable bearings on the truck A, and rotated by a motive-power independent of that which drives the locomotive, to which motive-power there should be a reversing appliance for giving either a right or left motion to the discharger, according to which side of the track it is desired to deliver the snow.

I am aware that revolving blades arranged in front of a locomotive, for clearing snow from the track, have been used before the invention herein explained, but with such contrivances it was never contemplated to employ a shovel and receiver, having a convex back, for gathering in the snow preparatory to its discharge from the track.

I am also aware that scoops or plows of various shapes have been used for gathering in and discharging snow from railroad-tracks in front of locomotives. I do not, therefore, claim as my invention any of these contrivances, separately considered.

The principle object of the covers of the snow-escape is to discharge the snow at a greater elevation at one time than at another, as, for instance, in deep cuts, or while passing trains. I close the slide, in such cases, on the side the snow was thrown.

Having described my invention,

What I claim as new, and desire to secure by Letters Patent, is—

1. The shovel C, surmounted by a flaring scoop, D, and provided with a revolving discharger, J, substantially as described.

2. The convex back P to the shovel and scoop, in combination with a revolving discharger, substantially as described.

3. The shovel and scoop, terminating in a cylindri-

cal portion E, through which is an escape-opening, O, provided with slides G, substantially as described.

4. The combination, with the truck A, of the depressed horizontal shovel C, having flaring sides and revolving blades J, substantially as described.

JOHN WHEELER ELLIOT.

Witnesses:

J. D. EDGAR,

S. M. WHITE.