

*W. Fuzzard.
Felting Machine.*

No. 12386.

Patented Feb. 13. 1855.

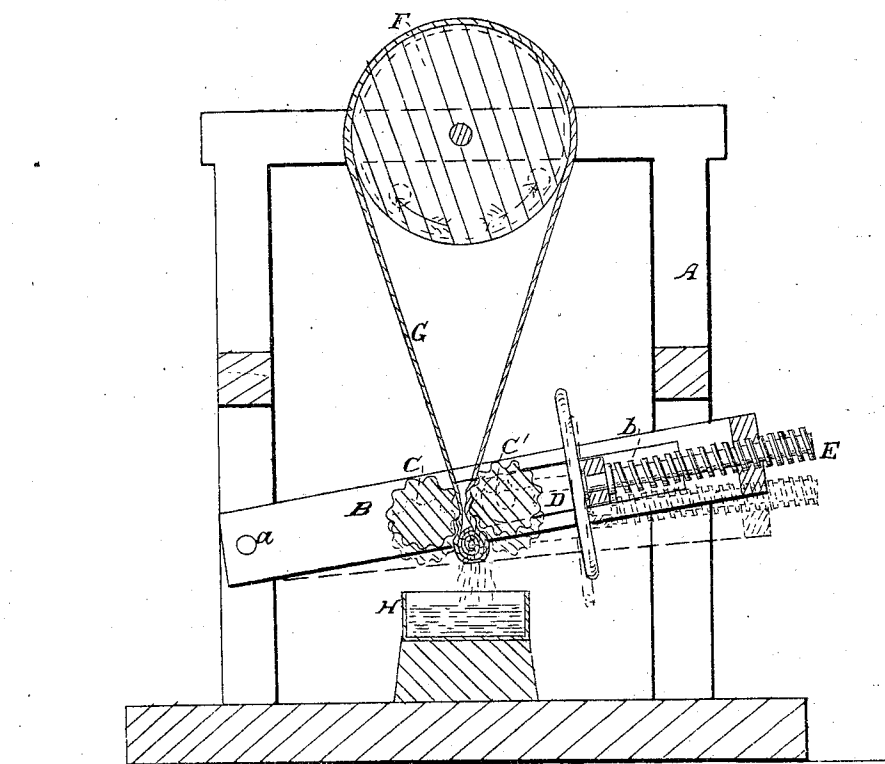

UNITED STATES PATENT OFFICE.

WILLIAM FUZZARD, OF NEWARK, NEW JERSEY.

MACHINERY FOR FELTING HAT-BODIES.

Specification forming part of Letters Patent No. 12,386, dated February 13, 1855; Reissued July 10, 1855, No. 314.

To all whom it may concern:

Be it known that I, WILLIAM FUZZARD, of Newark, in the county of Essex and State of New Jersey, have invented a new and
5 Improved Machine for Felting Hat-Bodies; and I do hereby declare that the following is a full, clear, and exact description of the same, reference being had to the annexed drawing, making a part of this specification,
10 said drawing being a longitudinal vertical section of my improved machine, the plane of section being through the center.

The nature of my invention consists in the employment or use of a pair of corrugated rollers, placed in a swinging frame,
15 in combination with an endless apron working over a driving drum or cylinder and between the corrugated rollers. The above parts being constructed, arranged and operating, as will be hereafter fully shown
20 and described.

To enable others skilled in the art to fully understand and construct my invention, I will proceed to describe it.

25 A, represents a rectangular frame, having a swinging frame B, secured within it, one of the pivots on which the swinging frame works, being shown at (a). The swinging frame is of rectangular form, and
30 is provided with two corrugated rollers, C, C', placed transversely within it. The axis of the roller, C, works in permanent bearings in the frame, B, but the axis of the roller, C', has its bearings in slides, D,
35 which work in grooves (b) in the inner surfaces of the side pieces of the frame B, the slides being operated by a screw, E, so that the roller, C', may be adjusted nearer to, or farther from the roller, C, as desired.

40 F, is a drum, the axis or shaft of which runs in suitable bearings on the upper part of the frame, A. The drum is placed transversely on the frame A, and parallel with the rollers, C, C', in the swinging frame,
45 B. Around the drum, F, there is an endless apron G, formed of any suitable material. This apron is of sufficient length to pass between the rollers, C, C', and extend a short distance below them.

50 H, is a trough or basin secured to the lower part of the frame, A, and underneath the rollers, C, C',—the length of the trough or basin corresponding with that of the rollers.

Operation: The roller, S', is first moved 55 a suitable distance from the roller, C, by operating the screw, E, and the hat bodies to be felted are rolled up by hand, a suitable number together and placed in the fold at the lower part of the endless apron, G. 60 The roller, C', is then moved near the roller C, and a rotary, reciprocating motion is given the drum, F, by hand, or otherwise, and the hat bodies receive a similar motion within the apron, G, underneath the rollers, 65 C, C', and the requisite pressure is given the hat bodies against the rollers, by depressing or bearing with the hand upon the outer end of the swinging frame, B.

The advantage of the above invention is 70 that the pressure of the rollers-upon the hat bodies may be graduated with the greatest nicety. This is important, for the hat bodies when first acted upon, or when first put in the machine, are extremely 75 tender and liable to be ruptured. By my improved machine, a very slight pressure may be first given them, and precisely similar to that of hand pressure. After the bodies are somewhat felted and have sufficient strength the pressure may be increased 80 by depressing the swinging frame still more, and a continuous rotary motion given the drum, F.

The hat bodies are moistened as usual before 85 being operated upon by the machine, and the trough or basin, H, receives the moisture expressed from them, by the pressure of the rollers, C, C'.

I do not claim the corrugated rollers, 90 C, C', separately, for they have been previously used, although differently arranged from those herein described; but

What I claim as new and desire to secure 95 by Letters Patent is,

The employment or use of the corrugated rollers, C, C', placed in a swinging frame, B, in combination with the endless apron, G, the above parts being constructed, arranged, and operating, in the manner and 100 for the purpose as herein shown and described.

WILLIAM FUZZARD.

Witnesses:

S. H. WALES,
J. G. MASON.