



INTERNATIONAL APPLICATION PUBLISHED UNDER THE PATENT COOPERATION TREATY (PCT)

<p>(51) International Patent Classification <sup>7</sup> : <b>H04L 29/12, G06F 17/30</b></p>	<p><b>A1</b></p>	<p>(11) International Publication Number: <b>WO 00/56035</b> (43) International Publication Date: 21 September 2000 (21.09.00)</p>
<p>(21) International Application Number: PCT/US00/03687 (22) International Filing Date: 14 February 2000 (14.02.00) (30) Priority Data: 60/124,956 18 March 1999 (18.03.99) US 09/358,043 21 July 1999 (21.07.99) US (71) Applicant (for all designated States except US): WALID, INC. [US/US]; State Technology Park, 2245 South State Street, Ann Arbor, MI 48104 (US). (72) Inventor; and (75) Inventor/Applicant (for US only): TOUT, Walid, R. [US/US]; 1938 Upland Drive, Ann Arbor, MI 48105 (US). (74) Agent: KRAGULJAC, Petar; Calfee, Halter &amp; Griswold LLP, 1400 McDonald Investment Center, 800 Superior Avenue, Cleveland, OH 44114-2688 (US).</p>	<p>(81) Designated States: AL, AM, AT, AU, AZ, BA, BB, BG, BR, BY, CA, CH, CN, CU, CZ, DE, DK, EE, ES, FI, GB, GE, GH, GM, HR, HU, ID, IL, IS, JP, KE, KG, KP, KR, KZ, LC, LK, LR, LS, LT, LU, LV, MD, MG, MK, MN, MW, MX, NO, NZ, PL, PT, RO, RU, SD, SE, SG, SI, SK, SL, TJ, TM, TR, TT, UA, UG, US, UZ, VN, YU, ZW, ARIPO patent (GH, GM, KE, LS, MW, SD, SL, SZ, TZ, UG, ZW), Eurasian patent (AM, AZ, BY, KG, KZ, MD, RU, TJ, TM), European patent (AT, BE, CH, CY, DE, DK, ES, FI, FR, GB, GR, IE, IT, LU, MC, NL, PT, SE), OAPI patent (BF, BJ, CF, CG, CI, CM, GA, GN, GW, ML, MR, NE, SN, TD, TG).</p> <p><b>Published</b> <i>With international search report. Before the expiration of the time limit for amending the claims and to be republished in the event of the receipt of amendments.</i></p>	

(54) Title: METHOD AND SYSTEM FOR INTERNATIONALIZING DOMAIN NAMES

(57) Abstract

A method and system for internationalizing domain names is provided which allows domain names to be entered in any language without having to modify the existing Internet domain name servers. When a user enters a domain name including non-English characters into an internet program, a domain name transformer intercepts the domain name prior to reaching the resolver. The domain name is converted to a standard format which can represent all language character sets, such as UNICODE. The UNICODE string is then transformed to be in RFC1035 compliant format. Redirector information is then appended to the compliant string which identifies the delegation of authoritative root servers and/or domain name servers responsible for the domain name. The compliant domain string is then resolved by the authoritative domain name server just as any English domain name.

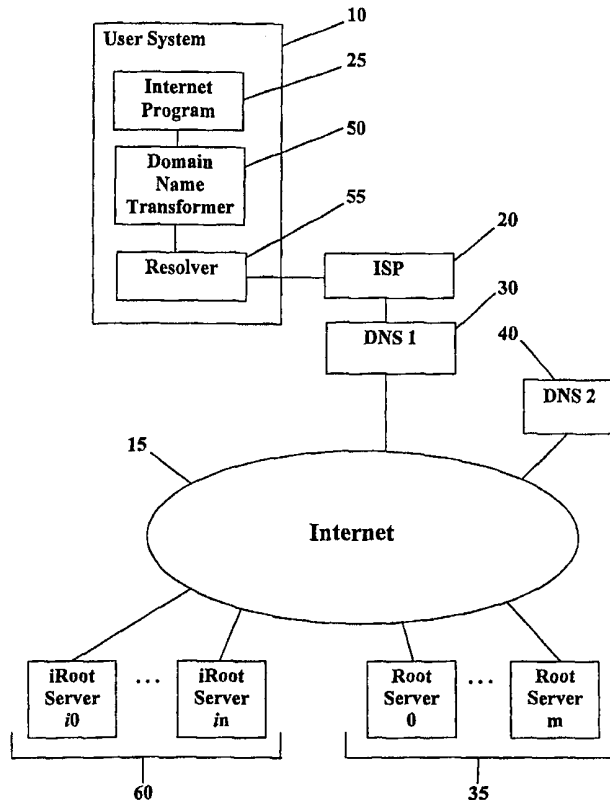

**FOR THE PURPOSES OF INFORMATION ONLY**

Codes used to identify States party to the PCT on the front pages of pamphlets publishing international applications under the PCT.

AL	Albania	ES	Spain	LS	Lesotho	SI	Slovenia
AM	Armenia	FI	Finland	LT	Lithuania	SK	Slovakia
AT	Austria	FR	France	LU	Luxembourg	SN	Senegal
AU	Australia	GA	Gabon	LV	Latvia	SZ	Swaziland
AZ	Azerbaijan	GB	United Kingdom	MC	Monaco	TD	Chad
BA	Bosnia and Herzegovina	GE	Georgia	MD	Republic of Moldova	TG	Togo
BB	Barbados	GH	Ghana	MG	Madagascar	TJ	Tajikistan
BE	Belgium	GN	Guinea	MK	The former Yugoslav Republic of Macedonia	TM	Turkmenistan
BF	Burkina Faso	GR	Greece			TR	Turkey
BG	Bulgaria	HU	Hungary	ML	Mali	TT	Trinidad and Tobago
BJ	Benin	IE	Ireland	MN	Mongolia	UA	Ukraine
BR	Brazil	IL	Israel	MR	Mauritania	UG	Uganda
BY	Belarus	IS	Iceland	MW	Malawi	US	United States of America
CA	Canada	IT	Italy	MX	Mexico	UZ	Uzbekistan
CF	Central African Republic	JP	Japan	NE	Niger	VN	Viet Nam
CG	Congo	KE	Kenya	NL	Netherlands	YU	Yugoslavia
CH	Switzerland	KG	Kyrgyzstan	NO	Norway	ZW	Zimbabwe
CI	Côte d'Ivoire	KP	Democratic People's Republic of Korea	NZ	New Zealand		
CM	Cameroon			PL	Poland		
CN	China	KR	Republic of Korea	PT	Portugal		
CU	Cuba	KZ	Kazakstan	RO	Romania		
CZ	Czech Republic	LC	Saint Lucia	RU	Russian Federation		
DE	Germany	LI	Liechtenstein	SD	Sudan		
DK	Denmark	LK	Sri Lanka	SE	Sweden		
EE	Estonia	LR	Liberia	SG	Singapore		

**METHOD AND SYSTEM FOR INTERNATIONALIZING DOMAIN  
NAMES**

**BACKGROUND OF THE INVENTION**

5

The present invention relates to the internet arts. It finds particular application to a method and system for internationalizing internet domain names such that a non-compliant international domain name can be processed by the existing internet structure.

10

With the proliferation and extremely fast adoption of the Internet around the globe, the need for international capabilities on the Net has become a matter of absolute necessity. A lot of work has been done so far on the subject of localization of scripts and the internationalization (I18N) of systems. However, up to this date, the Internet has remained more associated and very tightly dependent upon the English language since the current Domain Name System (DNS) is presently restricted to the monospace 7 bit ASCII English language alphabet.

15

20

The Domain Name System is the part of the Internet infrastructure that translates human-readable domain names into the Internet Protocol (IP) numbers needed to establish TCP/IP communication over the Internet. So far, existing domain name server systems accept only domain names according to RFC1035. RFC1035 specifies the alphabet (set of allowed symbols), the syntax and all restrictions for permissible/valid domain names. Currently, only A to Z upper case, a to z lower case, the "-" and "." are permitted.

25

30

There have been proposals which suggest changing the domain name server system to accommodate I18N. While the proposed solution could work, it requires major changes to the Internet as it exists today. Domain name servers around the globe, which number in the thousands, would have to be changed or updated. In the meantime, existing domain name servers would not be able to handle the new queries sent to them by I18N-enabled domain name

servers. Results of these I18N queries can vary anywhere from single rejection to a complete crash of the non-enabled domain name servers.

5 The present invention provides a solution to this problem in that the present invention would allow users of the Internet to use international domain names mainly in their own script or characters. The present invention works with the existing domain name servers around the world and does not require any updates to be applied to these servers nor any changes to be made to their configurations.

10

The present invention provides a new and unique method and system for internationalizing domain names which cures the above problems and others.

### SUMMARY OF THE INVENTION

15

In accordance with the present invention, a method of converting an internet international domain name to an RFC1035 compliant format is provided. The international domain name includes non-English characters which are RFC1035 non-compliant. The international domain name is intercepted and transformed to an RFC1035 compliant domain name. A  
20 redirector string is generated which includes information for resolving the RFC1035 compliant domain name. The redirector string is then appended to the RFC1035 compliant domain name.

25 In accordance with a more limited aspect of the present invention, the intercepting is transparent to the user and occurs on a user's computer.

In accordance with a more limited aspect of the present invention, the international domain name is converted to a UNICODE string which includes a  
30 16-bit format. The 16-bit format is then transformed to a 5-bit format which is RFC1035 compliant.

In accordance with another aspect of the present invention, in a system for accessing the Internet from an user computer by obtaining a domain name where a domain name server requires the domain name to be in a first format, a method for requesting an international domain name which is in a second  
5 format is provided. The international domain name is obtained and transformed from the second format to the first format which is acceptable by the domain name server. The transformed international domain name is then transmitted to the domain name server. The domain name server resolves the transformed name to obtain an IP number corresponding to the international domain name.  
10 The user can then access the internet using the IP number.

In accordance with a more limited aspect of the present invention, the international domain name is transparently intercepted on the user computer and analyzed to determine the second format.  
15

In accordance with another aspect of the present invention, a system for requesting international domain names with a user machine in communication with the Internet is provided. A domain name server is connected to the Internet which resolves a domain name request by retrieving an IP number  
20 corresponding to the domain name. The domain name server requires the domain name to be in a first character format. An Internet program provides communication between the user machine and the Internet. The internet program allows the user to request communication to an internet location by obtaining a domain name of the internet location which is an international  
25 domain name having a second character format that is different than the first character format. A domain name transformer transforms the international domain name to a compliant domain name which has the first character format. The domain name transformer is installed on the user machine. The transformation is performed transparent to both the user and the domain name  
30 server. A resolver receives and resolves the compliant domain name from the domain name transformer into an IP number of the internet location by transmitting the compliant domain name to the domain name server which

returns an IP number of the internet location corresponding to the compliant domain name and thus allows communication with the internet location.

5 In accordance with a more limited aspect of the present invention, the domain name transformer appends a redirector string to the compliant domain name which provides delegation instructions for resolving the complaint domain name.

10 One advantage of the present invention is that domain name transformer is provided at the user level which allows any character to be used in a domain name. The transformation is performed transparent to the user and transparent to the current Internet protocols.

15 Another advantage of the present invention is that international domain names are converted to RFC1035 compliant format such that current domain name servers do not have to be modified in order to accept international domain names inputted by an user. The invention allows the use of international domain names with the existing Internet infrastructure and does not require its modification.

20

Another advantage of the present invention is that it works on the user's machine and is totally transparent to all standard, compliant software programs. Not only will the browser, e-mail, ftp, telnet, gopher, news and other common internet programs function with the present invention, but all compliant Internet programs will work transparently with the present invention.

25

Another advantage of the present invention is that transformation of a domain name and generation of the redirector information is performed on an user's computer prior to being received by a domain name server. In this manner, the domain name server is unaware that domain name requests are being processed by an international root server.

30

Another advantage of the present invention is that the domain name transformation allows for a reverse look-up transformation such that an IP number can be reverse transformed to obtain its corresponding international domain name.

5

Still further advantages of the present invention will become apparent to those of ordinary skill in the art upon reading and understanding the following detailed description of the preferred embodiments.

10

### **BRIEF DESCRIPTION OF THE DRAWINGS**

The following is a brief description of each drawing used to describe the present invention, and thus, are being presented for illustrative purposes only and should not be imitative of the scope of the present invention, wherein:

15

**Figure 1** illustrates an Internet and user configuration in accordance with the present invention; and

**Figure 2** illustrates the domain name transformation process in accordance with the present invention.

20

### **DETAILED DESCRIPTION OF THE PREFERRED EMBODIMENTS**

With reference to **Figure 1**, a user system **10** is typically connected to the Internet **15** through an Internet service provider (ISP) **20**. The following description works with any Internet compliant programs such as a browser, email, ftp, telnet, gopher, news, and others as is know in the art. A browser is used here for exemplary purposes. An Internet program **25**, such as a browser, runs on the user's computer and provides an interface between the user **10** and the Internet **15**. The browser **25** helps the user maneuver through sites on the Internet **15** and communicate information between the user **10** and the sites.

30 The user establishes a connection to a site by requesting a domain name of the site into the browser **25**. The browser initiates resolution of the domain name

which ultimately results in obtaining an Internet protocol number (hereinafter "IP number") that is an Internet address of the website or other Internet location identifier corresponding to the domain name as is known in the art.

5 A domain name server (DNS1) **30** is connected to the internet service provider **20** and processes domain name requests to retrieve a corresponding IP number. Currently, there are about 300,000 domain name servers throughout the world each being responsible for the domain names of a group of domains which were registered to that domain name server. Each domain name server includes a database containing registered domain names, their corresponding IP  
10 number/address, and other domain related information. If the domain name requested is unknown to the domain name server **30**, it will consult a root server selected from a group of root servers **35**. Currently, there are about 13 main root servers throughout the world.

Each root server **35** handles a pre-determined set of domain names based  
15 on its top level domain. For example, there are a few root servers responsible for handling all domain names with ".com" as their top level domain. Another set of root servers is responsible for all domain names having ".org" as its top level domain and so on. For each domain name registered within a root server, the root server identifies which domain name server (or another root server) is  
20 responsible for the domain name. Current root servers are configured to store a primary domain name server address and up to four back-up domain name servers which are responsible for resolving the domain name requested. The processing is then transmitted by DNS1 **30** to the appropriate domain name server, for example, domain name server (DNS2) **40** which returns an IP  
25 number for the domain name requested. This resolution process many involve more intermediate DNS servers along the way but will always function in a similar manner to what was explained here. The user may then connect to the site corresponding to that IP number. Of course, once the IP number is known, any Internet connection (e.g. Telnet, ftp, etc.) can be made.

As mentioned in the background section, current domain name servers are limited to receiving domain names which are RFC1035 compliant. In other words, domain names must be in the English alphabet. The present system cures this short coming by allowing a user **10** to request a domain name that includes non-English characters (which is hereinafter called an “international domain name”). In order to avoid modifying the domain name servers to handle such a request, the international domain name is converted by the present system to an RFC1035 compliant domain name before it is received by the domain name server.

With further reference to **Figure 1**, a domain name transformer **50** is installed in the user’s system **10** and includes a software layer that is inserted inside the TCP/IP stack on the computer system. This layer is positioned to intercept all domain resolution calls on the user’s system prior to reaching the resolver **55**. In a Windows based system, if Winsock 1.x (a Windows socket layer) is operating on the user’s system, the winsock.dll is shifted in the processing sequence by a new winsock.dll. The new winsock.dll is positioned before the original winsock.dll so that domain name function calls, such as GetXbyY, are intercepted. The new winsock.dll then transforms the international domain names as described below. After the transformation, the new winsock.dll passes the processing to the original winsock.dll with the transformed domain name. Other function calls directed to Winsock that are not related to domain name functions pass-through the new winsock.dll to the original winsock.dll. Another version of Winsock, Winsock 2, includes Layered Service Provider (LSP) and Name Space Provider (NSP) which are both layers. The NSP provides the GetXbyY function so that queries that have to resolve a domain name are performed by this component. In the case of Winsock 2, the present system installs a new version of the NSP which is a domain name server NSP replacing the original NSP or adds an additional NSP layer to function with the original NSP. When the new NSP receives a domain name, it applies the transformation logic of the present invention to transform an international domain name to a compliant format, and then calls the original resolver function **55** (e.g. GetXbyY, WSAGetXbyY) with the transformed

name. Regardless of the user's original software, it will be appreciated that the present invention can be installed at any desired position in the processing sequence on the user's machine such that an international domain name is intercepted/obtained, and transformed before it reaches a domain name server  
5 (e.g. between the origination of the domain name and the resolving of the domain name).

With the present transformation software in place, when the user requests an international domain name, the domain name transformer **50** intercepts the request and converts the international domain name to an  
10 RFC1035 compliant format. The transformation is performed transparent to the user and to the other components of the system so that additional modifications to the system are not required. Once the international domain name is transformed to a proper format, it is then passed to the resolver **55** which completes the domain resolution call function. The resolver **55** communicates  
15 to the domain name server **30** where the domain name is resolved as usual. Thus, the current domain name servers are unaware of the transformation and do not have to be modified in order to process an international domain name. The present invention, using redirector information, allows an existing domain name server to resolve an international domain name in the same manner as  
20 domain names are currently resolved.

With reference to **Figure 2**, the transformation process is shown. When an international domain name is requested **100**, the domain name is intercepted **110** before it reaches the system's domain name resolver **55**. In other words, the domain name is obtained by the present system whether it is entered by the  
25 user, activated from a hyperlink, or obtained in any other manner as is known in the art. The domain name is traversed to determine if any character exists which is not RFC1035 compliant. If any such character exists, then the domain name is considered to be an international domain name. Depending on the user's version of software, UNICODE is either supported or not. If UNICODE  
30 is not supported, the present system performs the additional steps of determining the language **115** of the international domain name and then

converting **120** the international domain name to its corresponding UNICODE string. The language of the domain name is determined from the active code page ID from the user's system. The code page ID identifies what language the domain name is in and, thus, identifies its character set. By knowing the  
5 character set, the international domain name is converted to its UNICODE string as is known in the art. If, however, the user's system supports UNICODE, these previous two steps are skipped because the domain name will already be put in UNICODE format by the system. The UNICODE string is then transformed **125** to an RFC1035 compliant format which is described as  
10 follows.

The current domain name protocol RFC1035 includes only 37 characters. Using binary format, at least 5-bits are required to represent 37 values. UNICODE, however, is a 16-bit format. Thus, in the preferred embodiment, the 16-bit format of the UNICODE string is transformed to a 5-bit  
15 format that is RFC1035 compliant. This transformation, called UTF-5, is described in the memorandum "Internationalization Of Domain Names," by H. Duerst, July 1998 which is incorporated herein by reference.

Several encodings for the Universal Character Set (UCS), so called UCS Transform Formats (UTF), exist already, namely UTF-8 [RFC2044], UTF-7  
20 [RFC1642], and UTF-16 [UNICODE]. Unfortunately, none of them is suitable for the present transformation from 16-bits to 5-bits. Therefore, UTF-5 is defined to perform this encoding using the following principles:

- To accommodate the slanted probability distribution of characters in UCS4 (Universal Character Set four bytes long), a variable-length encoding is used.
- 25 - Each target letter encodes 5 bits of information. Four bits of information encode character data, the fifth bit is used to indicate continuation of the variable-length encoding.
  - Continuation is indicated by distinguishing the initial letter from the subsequent letter.
- 30 - Leading four-bit groups of binary value 0000 of UCS4 characters are discarded, except for the last two groups (i.e. the last octet). This means that

looking at the UNICODE layout map of languages, ASCII and Latin-1 characters need two target letters, the main alphabets up to and including Tibetan need three target letters, the rest of the characters in the BMP need four target letters, all except the last (private) plane in the UTF-16/Surrogates area  
 5 [UNICODE] need five target letters, and so on.

- The letters representing the various bit groups in the various positions are chosen according to the following table:

Nibble Value		Initial
Hex	Binary	
10	0	0000 G 0
	1	0001 H 1
	2	0010 I 2
	3	0011 J 3
	4	0100 K 4
15	5	0101 L 5
	6	0110 M 6
	7	0111 N 7
	8	1000 O 8
	9	1001 P 9
20	A	1010 Q A
	B	1011 R B
	C	1100 S C
	D	1101 T D
	E	1110 U E
25	F	1111 V F

As an example, suppose a current domain is “is.s.u-tokyo.ac.jp” with the components standing for information science (is), science (s), the University of Tokyo (u-tokyo), academic (ac), and Japan (jp). This might be represented by  
 30 “JOUHOU.RI.TOUDAI.GAKU.NIHON” (a transliteration of the kanji that might probably be chosen to represent the same domain). Writing each character in U+HHHH notation as in UNICODE (represented by a “U+” and four hexadecimal digits HHHH), this results in the following:

35 U+60c5U+5831.U+7406.U+6771U+5927.U+5b66.U+65e5U+672c

This UNICODE string is given for reference only. It is not the actual encoding or something being typed in by the user. The UNICODE string is then transformed to RFC1035 compliant format according to UTF-5 before

submitting it to the domain name server resolver. The UNICODE string becomes:

M0C5L831.N406.M771L927.LB66.M5E5M72C

5

Using the above table, it is seen that the HHHH component "60c5" is transformed to "M0C5" since "6" is encoded to "M." The "5831" becomes "L831" and so on.

10

Of course, the transformations of the present invention are dependent on the current protocols and standards. Thus, if the protocols are changed such that different character sets are used, the transformation would change to adopt the new protocols. It will be appreciated that if RFC1035 is no longer the complaint standard for domain names, the present invention can be easily modified such that the transformation converts the international domain names to the new domain name standard format.

15

The following is an another example that illustrates the present translation process:

صفحة وليد	Domain name as it appears on the screen as typed by user in Arabic.
d5 dd cd c9 dc e6 el ed cf	Corresponding system character code representation
	Code Page ID as returned by system is charset1256 (Arabic). The corresponding UNICODE Range 0x0600-0x06ff
0635 0641 062d 0629 0640 0648 0644 064a 062f	Translation of character codes into the corresponding UNICODE codes
M35M41M2dM29M40M48M44M4aM2f	Apply the restricted mapping from UNICODE to a RFC1035 compliant name (using the UDM - United Data Mapper)
ar.il8n.net	Use UDM to determine the redirector information including an iroot server set based on the UNICODE range; Select the candidate iroot server from the returned set
M35M41M2dM29M40M48M44M4aM2f.ar.il8n.net	Construct the final domain name by appending the redirector information to the RFC1035 compliant domain

	name obtained above
	Pass the final domain name to the TCP/IP layer below to perform name resolution per the normal operation.

With further reference to **Figure 2**, after the above transformation, the international domain name is in RFC1035 compliant format. The string “ar.il8n.net” is redirector information **130** that is appended to the converted string and functions like a top level domain, and identifies the authoritative domain name server responsible for the current domain name. Once the redirector information is appended to the domain name, the domain name becomes a fully qualified domain name (FQDN). A fully qualified domain name includes at least a top level domain and a secondary domain which is enough information to resolve the domain name. As explained previously, the domain name server **30** resolves a domain name by inquiring the root server **35** (the root server responsible for the top level domain found in the domain name) about which domain name servers are authoritative domain name servers for the given domain name. The responsibility of top level domains such as, “.com”, “.net”, “.org”, “.edu”, etc., is assigned to a pre-selected set of root servers. Thus, the inquiry for a domain name such as “abc.net” would be directed to one of the root servers in the root server set responsible for “.net” domains.

The above redirector information “ar.il8n.net” provides the following exemplary delegation instructions for resolving the international domain name. Of course, any identifiers can be used to represent a domain set. The “il8n” identifies the domain name as “international” and the “ar” further identifies it as being in Arabic which is determined from the UNICODE range of the domain name characters. The domain resolution is explained as follows. The transformed compliant domain name including the redirector information is received by the domain name server **30** where it is attempted to be resolved. The domain name server **30** identifies the top level domain “.net” for which it is not an authoritative DNS. As such, the domain name server consults an authoritative root server which is responsible for .net domains, for example, root

server **m** from the root server group **35**. Examining the second level domain “i18n”, root server **m** determines from its database that the authoritative domain name server for this domain is, for example, DNS2 **40**. DNS1 **30** then communicates the entire domain to DNS2 **40**. DNS2 **40** first determines whether it is authoritative and delegated for this domain by scanning its database of registered domains. In this case, DNS2 **40** determines from the redirector information that the delegated server for “ar.i18n.net” (Arabic domains) is the *ir*oot server **i3** from *ir*oot server group **60**. The resolution continues in the predescribed manner until the authoritative DNS for the current domain is determined which returns the IP number of the domain name. The foregoing example assumes that the domain “i18n.net” and sub-domain “ar.i18.net” were properly pre-assigned and registered to the appropriate root servers and domain name servers.

In the preferred embodiment, the redirector information controls the delegation path for resolving the domain name. The redirector information can be a single unique top level domain which identifies an international root server (*ir*oot server) or may include multiple levels of identifiers such as “ar.i18n.net”. As shown in **Figure 1**, a group of *ir*oot servers **60** are connected to the Internet. For exemplary purposes, the *ir*oot servers are identified as **i0, i1, . . . in**. Of course, any type of identifiers can be used to name the root servers. Each *ir*oot server **60** is configured to function in the same manner as any other root server **35** which handle English domain names.

Another example of using the redirector information would include appending “.**i3**” to the converted domain name string. To generate the redirector information, the system determines which *ir*oot server is responsible for the domain name. For this purpose, the UNICODE string is examined using a Unified Domain Mapper (UDM). The character values of the UNICODE string will belong to a specific character range. The character range in turn identifies the character set/language of the international domain name (e.g. Arabic, Japanese, etc.) Thus, if it is determined that the international domain name was entered in Arabic, the system selects the *ir*oot server which is

responsible for Arabic domain names (e.g. “i3”) and “.i3” becomes the top level domain. The domain name server 30 then knows to direct the domain name request to the proper *ir*oot server to query for the user’s specified domain/host based on the redirector information, in this case, *ir*oot server *i3*. Alternately, the  
5 redirector information may be generated from a predetermined string that covers all or a sub-set of the international domains. For example, “.i” can represent all international domains, “.ap” can represent a sub-set “Asia pacific”, “.ar” can represent a sub-set “Arabic” or any other predetermined identifiers. This predetermined redirector can be appended to the transformed domain name by  
10 the software. Of course, any predetermined string can be used to identify an international domain and identify a responsible server. Alternately, the user or internet program can supply the redirector information along with the domain name, thus generating the redirector information. In this way, the user or program adds a “.i” to a domain name which identifies it as international.

15

With further reference to **Figure 2**, after the transformation, the RFC1035 compliant domain name includes the transformed domain name and the appended redirector information which makes it a fully qualified domain name. The compliant domain name is sent to the resolver where it is resolved  
20 135 according to the resolver functions as described above. The resolver function communicates with the domain name server 30 and the process continues until the proper IP number corresponding to the original domain name is returned.

25 With the present invention, the international domain name transformation allows for the reverse look-up of domain names from their corresponding IP number. Each domain name server contains a data base of registered domain names and their corresponding IP number. Given an IP number, the domain name can be retrieved. This name, of course, is an  
30 RFC1035 compliant name which can be converted back to a UNICODE formatted string. The UNICODE string can then be translated back to its original character set in the original international language.

The present system also provides for dynamic modification of its software. When root servers are re-assigned or new root servers added, the redirector information must reflect these changes so that international domain names are properly resolved. The present system includes a periodic look-up  
5 function which periodically looks to root servers or other predefined locations on the internet to determine if changes have been made. If changes are made, modified software (such as a new UDM mapper) is provided automatically to the user system. In this manner, the present invention modifies and updates itself.

10

The present invention is transparent to the existing infrastructure of the Internet and is totally hidden in operation from both ends of the communication path, namely, the user **10** and the domain name server **30**. With the present invention, users are not required to add or change any configuration information  
15 on their computer systems. Users can keep the same Internet Service Provider **20**, the same computer system and the same network configuration. All that is required is to install the present system in the user's computer system **10** as described above. Once the present system is installed, the user can start using international domain names immediately. The Internet Service Provider (ISP)  
20 and the Domain Name Servers (DNS) do not have to change their present configurations.

The invention has been described with reference to the preferred embodiment. Obviously, modifications and alterations to others upon a reading  
25 and understanding of this specification. It is intended to include all such modifications and alterations insofar as they come within the scope of the appended claims are the equivalence thereof.

I claim:

1. A method of converting an internet international domain name to an RFC1035 compliant format, where the international domain name includes non-English characters which are RFC1035 non-compliant, the method  
5 comprising:
  - intercepting the international domain name;
  - transforming the international domain name to an RFC1035 compliant  
domain name;
  - 10 generating a redirector string which includes information for resolving the RFC1035 compliant domain name; and
  - appending the redirector string to the RFC1035 compliant domain name.
2. The method of converting as set forth in claim 1 further  
15 including obtaining the international domain name on a user system and, the intercepting being transparent to the user and occurring in the user system.
3. The method of converting as set forth in claim 2 wherein the  
20 intercepting occurs in a Windows socket layer where, if the Windows socket layer is Winsock 1.1, the converting includes shifting the Windows socket layer and adding a new winsock layer which performs the intercepting and transforming.
4. The method of converting as set forth in claim 3 wherein if the  
25 Windows socket layer includes a name space provider, the converting includes replacing the name space provider with another name space provider which performs the intercepting and transforming.
5. The method of converting as set forth in claim 3 wherein if the  
30 Windows socket layer includes a name space provider, the converting includes adding a new name space provider layer which performs the intercepting and transforming.

6. The method of converting as set forth in claim 1 further including, after the intercepting, converting the international domain name to a UNICODE string if the international domain name is not in a UNICODE  
5 format, and wherein the transforming includes transforming the UNICODE string to the RFC1035 compliant domain name.

7. The method of converting as set forth in claim 6 wherein the UNICODE string is a sixteen bit string and the transforming includes  
10 transforming the sixteen bit UNICODE string to a five bit string, the five bit string being in an RFC1035 compliant format.

8. The method of converting as set forth in claim 6 wherein the UNICODE string includes a plurality of characters, and the generating of the  
15 redirector string being based on the plurality of characters.

9. The method of converting as set forth in claim 1 wherein the redirector string includes a plurality of domain levels.

20 10. The method of converting as set forth in claim 1 wherein the redirector string is generated from a predetermined string.

11. In a system for accessing the internet from a user computer by obtaining a domain name where a domain name server requires the domain  
25 name to be in a first format, a method of accessing the internet with an international domain name comprising the steps of:

obtaining the international domain name being in a second format;

transforming the international domain name from the second format to the first format which is acceptable by the domain name server;

30 transmitting the transformed international domain name to the domain name server;

resolving the transformed international domain name by the domain name server to obtain an IP number corresponding to the international domain name; and

accessing the internet by the user computer using the IP number.

5

12. The method of accessing the internet as set forth in claim 11 further including, after the obtaining:

transparently intercepting the international domain name on the user computer, and;

10 analyzing the international domain name to determine the second format.

13. The method of accessing the internet as set forth in claim 12 further including converting the second format into UNICODE before  
15 transforming into the first format.

14. The method of accessing the internet as set forth in claim 13 wherein the first format is an RFC1035 compliant format and the second format is an RFC1035 non-compliant format.

20

15. The method of accessing the internet as set forth in claim 11 further including generating a redirector string and appending the redirector string to the transformed international domain name prior to transmitting to the domain name server, the redirector string identifying an authoritative server  
25 which is responsible for the international domain name such that the domain name server communicates with the authoritative server to obtain the IP number.

16. The method of accessing the internet as set forth in claim 15  
30 wherein the redirector string includes a plurality of domain levels.

17. The method of accessing the internet as set forth in claim 15 wherein the redirector string is generated from a predetermined identifier.

18. The method of accessing the internet as set forth in claim 12 wherein the intercepting is performed in a Windows socket layer.

5 19. The method of accessing the internet as set forth in claim 18 wherein if the Windows socket layer is Winsock 1.1, the method further includes adding an additional winsock layer which performs the intercepting and transforming before the Windows socket layer.

10 20. The method of accessing the internet as set forth in claim 18 wherein if the Windows socket layer includes a name space provider, the converting includes replacing the name space provider with a new name space provider which performs the intercepting and transforming.

15 21. The method of accessing the internet as set forth in claim 18 wherein if the Windows socket layer includes a name space provider, the converting includes adding a new name space provider layer which performs the intercepting and transforming.

20 22. A system for requesting international domain names with a user machine in communication with an internet where the internet includes a domain name server which resolves a domain name request by retrieving an IP number corresponding to the domain name, the domain name server requiring the domain name to be in a first character format, the system comprising:

25 an internet program for providing communication between the user machine and the internet, the internet program allowing a user to request communication to an internet location by obtaining a domain name of the internet location, the domain name being an international domain name having a  
30 second character format different than the first character format;

a domain name transformer for transforming the international domain name to a compliant domain name having the first character format, the domain

name transformer being installed on the user machine, the transforming being performed transparent to both the user and the domain name server; and

5 a resolver for receiving and resolving the compliant domain name from the domain name transformer into an IP number of the internet location, the resolver transmitting the compliant domain name to the domain name server, the domain name server returning the IP number of the internet location corresponding to the international domain name to allow communication between the user machine and the internet location.

10 23. The system as set forth in claim 22 wherein the domain name transformer converts the international domain name to a UNICODE string if the international domain name includes a non-UNICODE format, and the UNICODE string being transformed to the first character format.

15 24. The system as set forth in claim 22 further including an international root server which communicates with the domain name server, the international root server identifying a location of a domain name server responsible for the international domain name and maintains a corresponding IP number.

20 25. The system as set forth in claim 24 wherein the domain name transformer further appends a redirector string to the compliant domain name, the redirector string identifying the international root server.

26. The system as set forth in claim 25 wherein the domain name transformer generates the redirector string based on the UNICODE string.

25 27. The system as set forth in claim 25 wherein the domain name transformer generates the redirector string based on a predetermined string.

30 28. The system as set forth in claim 22 further including a redirector generator for generating a redirector string including at least one domain level, the redirector string being appended to the compliant domain name for providing delegation instructions for resolving the complaint domain name.

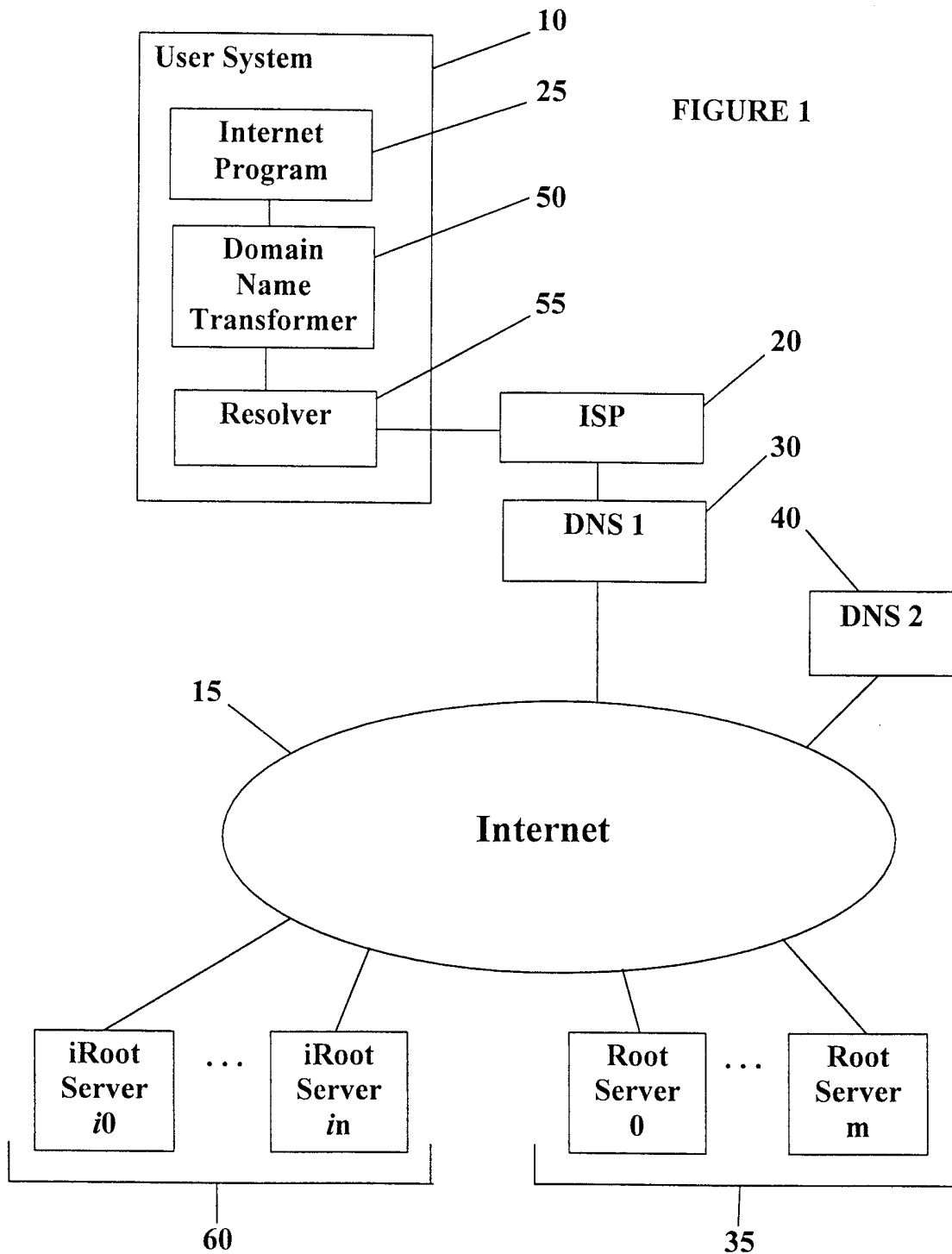

FIGURE 1

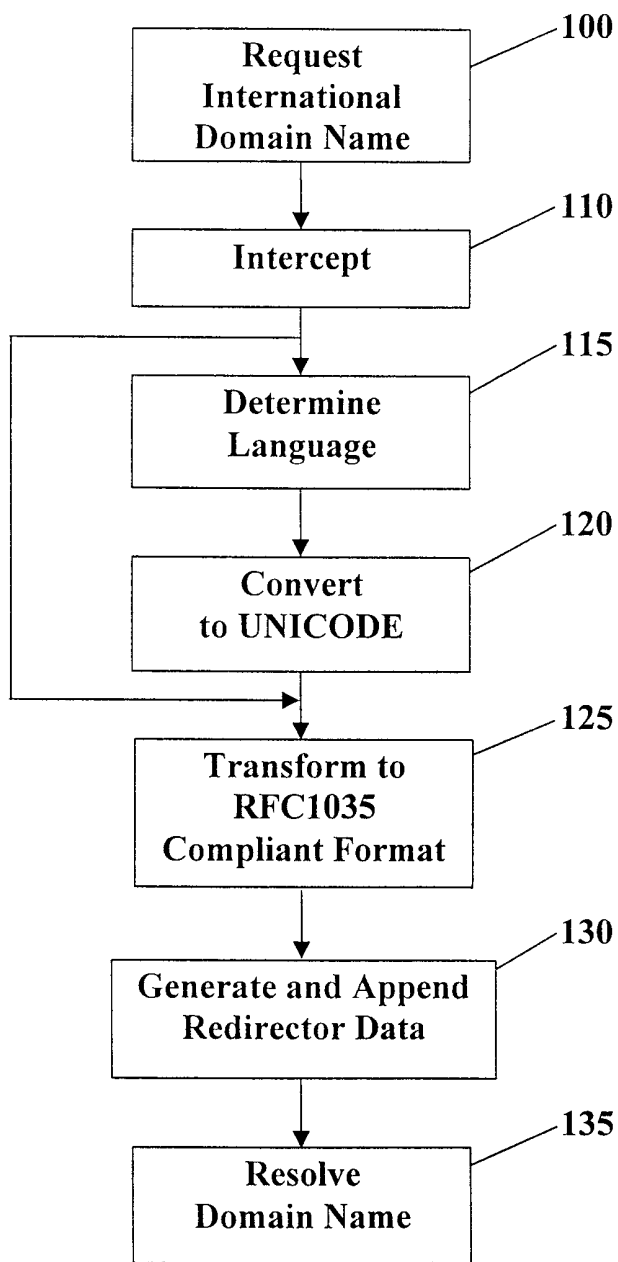

FIGURE 2

# INTERNATIONAL SEARCH REPORT

International Application No

PCT/US 00/03687

**A. CLASSIFICATION OF SUBJECT MATTER**  
 IPC 7 H04L29/12 G06F17/30

According to International Patent Classification (IPC) or to both national classification and IPC

**B. FIELDS SEARCHED**

Minimum documentation searched (classification system followed by classification symbols)

IPC 7 H04L G06F

Documentation searched other than minimum documentation to the extent that such documents are included in the fields searched

Electronic data base consulted during the international search (name of data base and, where practical, search terms used)

EPO-Internal, WPI Data, PAJ, INSPEC, IBM-TDB

**C. DOCUMENTS CONSIDERED TO BE RELEVANT**

Category	Citation of document, with indication, where appropriate, of the relevant passages	Relevant to claim No.
P,X	WO 99 39280 A (REFUAH AVIV ;ROTH ROBY (IL); DAYAGI GIL (IL); EASYNET ACCESS INC ) 5 August 1999 (1999-08-05)  abstract page 3, line 19 -page 4, line 18 page 11, line 32 -page 12, line 15; figure 2  ---	1-3, 9-12, 15-18, 22, 24, 25, 27, 28
P,X	WO 99 19814 A (POUFLIS JASON) 22 April 1999 (1999-04-22)  abstract page 1, line 30 -page 2, line 22 page 8, line 34 -page 12, line 24  --- -/--	1-3, 9-12, 15-18, 22, 24, 25, 27, 28

Further documents are listed in the continuation of box C.

Patent family members are listed in annex.

**Special categories of cited documents :**

- "A" document defining the general state of the art which is not considered to be of particular relevance
- "E" earlier document but published on or after the international filing date
- "L" document which may throw doubts on priority claim(s) or which is cited to establish the publication date of another citation or other special reason (as specified)
- "O" document referring to an oral disclosure, use, exhibition or other means
- "P" document published prior to the international filing date but later than the priority date claimed

- "T" later document published after the international filing date or priority date and not in conflict with the application but cited to understand the principle or theory underlying the invention
- "X" document of particular relevance; the claimed invention cannot be considered novel or cannot be considered to involve an inventive step when the document is taken alone
- "Y" document of particular relevance; the claimed invention cannot be considered to involve an inventive step when the document is combined with one or more other such documents, such combination being obvious to a person skilled in the art.
- "&" document member of the same patent family

Date of the actual completion of the international search

20 July 2000

Date of mailing of the international search report

08/08/2000

Name and mailing address of the ISA

European Patent Office, P.B. 5818 Patentlaan 2  
 NL - 2280 HV Rijswijk  
 Tel. (+31-70) 340-2040, Tx. 31 651 epo nl,  
 Fax: (+31-70) 340-3016

Authorized officer

Adkhis, F

# INTERNATIONAL SEARCH REPORT

International Application No

PCT/US 00/03687

C.(Continuation) DOCUMENTS CONSIDERED TO BE RELEVANT		
Category	Citation of document, with indication, where appropriate, of the relevant passages	Relevant to claim No.
A	<p>MAURO, M.: "Cultural issues in planet-wide internet management and administration"                      TECHNOLOGY AND SOCIETY, 1998. ISTAS '98, 'Online! 12 - 13 June 1998, pages 167-169, XP002143039                      Brussels, Belgium                      ISBN: 0-7803-4327-1                      Retrieved from the Internet:                      &lt;URL:http://ieeexplore.ieee.org&gt;                      'retrieved on 2000-07-19!                      abstract                      page 168, left-hand column, line 9 - line 22</p> <p style="text-align: center;">---</p>	1-28
A	<p style="text-align: center;">---</p> <p>"METHOD TO ALLOW A WINDOWS USER TO USE EXTENDED ANSI CHARACTERS SUPPORTED BY WINDOWS WHEN SPECIFYING USER IDS, PASSWORDS OR DOMAIN NAMES TO BE USED ON AN OS/2 NETWORK"                      IBM TECHNICAL DISCLOSURE BULLETIN, US, IBM CORP. NEW YORK,                      vol. 34, no. 10B,                      1 March 1992 (1992-03-01), page 362                      XP000302764                      ISSN: 0018-8689                      the whole document</p> <p style="text-align: center;">-----</p>	1-28

# INTERNATIONAL SEARCH REPORT

Information on patent family members

Int. l. Application No

PCT/US 00/03687

Patent document cited in search report	Publication date	Patent family member(s)	Publication date
WO 9939280 A	05-08-1999	AU 2183299 A AU 2296999 A WO 9939281 A	16-08-1999 16-08-1999 05-08-1999
WO 9919814 A	22-04-1999	AU 9524098 A	03-05-1999