

(19) **DANMARK**

(10) **DK/EP 2097613 T3**



(12) **Oversættelse af  
europæisk patentskrift**

Patent- og  
Varemærkestyrelsen

- 
- (51) Int.Cl.: **E 21 B 37/00 (2006.01)** **E 21 B 37/02 (2006.01)** **E 21 B 37/08 (2006.01)**
- (45) Oversættelsen bekendtgjort den: **2018-06-18**
- (80) Dato for Den Europæiske Patentmyndigheds bekendtgørelse om meddelelse af patentet: **2018-05-02**
- (86) Europæisk ansøgning nr.: **07865592.5**
- (86) Europæisk indleveringsdag: **2007-12-12**
- (87) Den europæiske ansøgnings publiceringsdag: **2009-09-09**
- (86) International ansøgning nr.: **US2007087287**
- (87) Internationalt publikationsnr.: **WO2008073986**
- (30) Prioritet: **2006-12-12 US 869712 P**
- (84) Designerede stater: **AT BE BG CH CY CZ DE DK EE ES FI FR GB GR HU IE IS IT LI LT LU LV MC MT NL PL PT RO SE SI SK TR**
- (73) Patenthaver: **Halliburton Energy Services, Inc., 3000 N. Sam Houston Parkway E., Houston, TX 77032, USA**
- (72) Opfinder: **KNOBLOCH, Benton T., 6127 Highway 90 E, Broussard, LA 70518, USA**  
**ROY, Todd J., 6127 Highway 90 E, Broussard, LA 70518, USA**
- (74) Fuldmægtig i Danmark: **NORDIC PATENT SERVICE A/S, Bredgade 30, 1260 København K, Danmark**
- (54) Benævnelse: **FORBEDRET BOREHULSSKRABE- OG/ELLER BØRSTEVÆRKTØJ OG RELATEREDE FREMGANGSMÅDER**
- (56) Fremdragne publikationer:  
**WO-A1-01/66907**  
**WO-A1-98/37305**  
**GB-A- 2 411 919**  
**US-A- 4 479 538**  
**US-A1- 2003 000 704**  
**US-A1- 2006 207 796**  
**US-B1- 6 464 010**



## DESCRIPTION

**[0001]** US6464010 describes a downhole cleaning assembly and method of cleaning a tubular according to the preamble of claims 1 and 8 in which the assembly comprises a mandrel connected to a work string. The mandrel has an opening and a pad member is received within the opening. The pad member has a groove within which is mounted a wire brush member for cleaning the internal diameter of the casing string.

### SUMMARY OF THE INVENTION

**[0002]** Various embodiments of the present invention generally relate to enhanced and improved wellbore cleaning tool or tool for casing surface cleaning. Generally, a downhole tool of the present invention is connected to a string of casing, such as a drill string used in a downhole environment.

**[0003]** In an embodiment, a downhole tool of the present invention comprises a mandrel operatively connected to a drill string, the mandrel having at least a first slot and at least a second slot therein. A first insert with a passageway therethrough is operatively received within the first slot and a second insert with a passageway therethrough is operatively received within the second slot. In varying embodiments, the first and/or the second insert is either a spring loaded scraping insert or a spring loaded brush insert comprising individually spring loaded pods or a spring loaded wire brush insert, both of which spring loaded wire inserts are capable of floating within the first insert and the second insert.

**[0004]** Various embodiments of the present invention generally provide for enhanced casing cleaning by at least one of contoured blade design(s) to provide superior tubular coverage, engagement and/or contact; contoured blade design to promote enlarged internal bore diameters for both the scraping insert and the brushing insert; for an embodiment comprising a brushing means, independent spring loaded pods for increased; enhanced; and/or, improved brushing operations by allowing independent extension of each pod or insert; interchangeable and adaptable construction to allow for various design components; and, improved component retention designs and apparatuses to reduce incidence of tool failure.

**[0005]** Downhole tools of the present invention are capable of use for cleaning an internal surface of a casing string. Various modifications to various profiles of embodiments of the present invention can be made to adapt tool embodiments to varying wellbore/casing situations, such as, but not limited to agglomerations of cement, downhole isolation and cleaning plugs, downhole collars, float equipment, casing scale, casing film, casing hydrate, agglomerations of substrate, pieces of drill string, casing deviation, including highly deviated casing, and/or the like. Various profiles include, but are not limited to drilling profiles, milling profiles, slick profiles, tapered profiles, tru-gauging/drift profiles and/or the like.

**[0006]** Further interchangeable adaptations possible with embodiments of the present invention include interchangeable housing portions located between the first insert and the second insert. Various embodiments of interchangeable housing portions include, but are not limited to, a blanking portion, a magnetic portion, a tru-gauge portion, combinations of the aforesaid, and/or the like.

**[0007]** Various other embodiments of the present invention generally comprise methods for brushing and/or scraping a surface of a casing; methods of constructing a brushing and/or scraping tool as herein described; and/or the like.

**[0008]** These and other features and advantages of the invention will be apparent to those skilled in the art from the following detailed description of a preferred embodiment, taken together with the accompanying figures and claims, in which:

### **BRIEF DESCRIPTION OF THE FIGURES**

**[0009]** In order that the manner in which the above-recited and other enhancements and objects of the invention are obtained, a more particular description of the invention briefly described above will be rendered by reference to specific embodiments thereof which are illustrated in the appended drawings. Understanding that these drawings depict only typical embodiments of the invention and are therefore not to be considered limiting of its scope, the invention will be described with additional specificity and detail through the use of the accompanying drawings in which:

Figure 1 is an illustration of an embodiment of a spring loaded scraping downhole tool.

Figure 2 is an illustration of a mandrel without any inserts, profdes or clamps.

Figure 3 is an illustration of a cross-section of the spring loaded blade insert from Figure 1.

Figure 4 is an illustration of the spring loaded blade insert from Figure 1.

Figure 5 is an illustration of a spring loaded wire brush downhole tool of the present invention.

Figure 6 is an illustration of the spring loaded wire pod insert with a passageway therehrough from Figure 5.

Figure 7 is an illustration of pod-loaded insert with a passageway therehrough from Figure 5.

Figure 8 is an illustration of an embodiment of an interchangeable profile capable of use with embodiments of the present invention.

Figure 9 is an illustration of an alternate embodiment of an interchangeable profile capable of use with embodiments of the present invention.

Figure 10 is an illustration of an alternate embodiment of an interchangeable profile capable of

use with embodiments of the present invention.

Figure 11 is an illustration of an embodiment of an interchangeable housing capable of use with various embodiments of the present invention.

Figure 12 is an illustration of an alternate embodiment of an interchangeable housing capable of use with various embodiments of the present invention.

Figure 13 is an illustration of an alternate embodiment of an interchangeable housing capable of use with various embodiments of the present invention.

Figure 14 is an illustration of a geared stabilizer spline for securing a profile.

Figure 15 is an illustration of an insert with a passageway therethrough of use with an alternate embodiment of the present invention.

Figure 16 is an illustration of the insert of Figure 15 from an underside perspective.

Figure 17 is an illustration of a brush insert for use in the insert of Figures 15 and 16.

## **DETAILED DESCRIPTION OF THE INVENTION**

**[0010]** The particulars shown herein are by way of example and for purposes of illustrative discussion of the preferred embodiments of the present invention only and are presented in the cause of providing what is believed to be the most useful and readily understood description of the principles and conceptual aspects of various embodiments of the invention. In this regard, no attempt is made to show structural details of the invention in more detail than is necessary for the fundamental understanding of the invention, the description taken with the drawings making apparent to those skilled in the art how the several forms of the invention may be embodied in practice.

**[0011]** The following definitions and explanations are meant and intended to be controlling in any future construction unless clearly and unambiguously modified in the following examples or when application of the meaning renders any construction meaningless or essentially meaningless. In cases where the construction of the term would render it meaningless or essentially meaningless, the definition should be taken from Webster's Dictionary, 3<sup>rd</sup> Edition.

**[0012]** As used herein, the term "attaches," or any conjugation thereof describes and refers the at least partial connection of two items.

**[0013]** As used herein, a "fluid" is a continuous, amorphous substance whose molecules move freely past one another and that has the tendency to assume the shape of its container, for example, a liquid or a gas.

**[0014]** As used herein, the term "integral" means and refers to lacking nothing essential after assembly.

**[0015]** Other than in the operating examples, or where otherwise indicated, all numbers expressing quantities of ingredients or reaction conditions used herein are to be understood as modified in all instances by the term "about".

**[0016]** Various embodiments of the present invention generally provide for enhanced casing cleaning by at least one of a contoured blade design to provide superior tubular coverage, engagement and/or contact; a contoured blade design to promote enlarged internal bore diameters for both the scraping insert and the brushing insert; for an embodiment comprising a brushing means, independent spring loaded pods and/or independent spring loaded wire brush insert for increased, enhanced, and/or improved brushing operations by allowing independent extension of each pod or wire brush insert; interchangeable and adaptable construction to allow for various design components; and/or, improved component retention designs and apparatuses to reduce incidence of tool failure.

**[0017]** Referring to Figure 1, an embodiment of a wellbore cleaning tool is disclosed as a spring loaded downhole tool 1 with scraping inserts is disclosed. Downhole tool 1 is commonly inserted as an integral one-piece or portion of a drill string within a wellbore. In various embodiments, tool 1 is positioned intermediate various other tools and/or drill string portions and connected through male portion 25 and female portion 26. Tool 1 is most preferred for use in casing strings that are to be cleaned. Generally downhole tool 1 comprises a mandrel 10, a first mounting portion 50, a second mounting portion 16, at least one first insert 2, at least one second insert 4, a first profile 5, and a second profile 30.

**[0018]** Generally, in an embodiment, mandrel 10 is of a generally similar size and/or circumference along its length with at least three cut away portions 60, 70, and 80. Cut away portion 60 is of a sufficient depth to allow mounting of insert 2 to a mounting slot within mounting portion 50. Likewise, cut away portion 80 is of a sufficient depth to allow mounting of insert 4 to a mounting slot within mounting portion 16. Cut away portion 70 is an optional component and allows for interchangeable mounting of various tool enhancers, such as, but not limited to a magnetic portion, a tru-gauge portion, a flow area enhancement portion, and/or the like.

**[0019]** In an alternate embodiment, first mounting portion 50 is an enlarged portion of mandrel 10 of sufficient thickness to allow machining of a mounting slot for at least one first insert 2. Likewise, in this alternate embodiment, second mounting portion 16 is an enlarged portion of mandrel 10 of sufficient thickness to allow machining of a mounting slot for at least one second insert 4.

**[0020]** In an alternate embodiment, mandrel 10 is of generally uniform circumference and the various further components of this invention are mounted to the mandrel.

**[0021]** Inserts of the present invention are inserted into at least one slot 54 cut into the mounting portions from the outermost ends and not from the center. In an embodiment, at least one insert 2 is inserted into a slot in mounting portion 50 from the outermost side and slid towards the center. Likewise, at least one insert 4 is inserted into a slot in mounting portion 16 from the outermost side and slid towards the center. All embodiments of a spring loaded brush insert comprise an insert with a passageway therehthrough.

**[0022]** Slots in mounting portion 50 and/or mounting portion 16 can generally be any size desired that is capable of accepting an insert. In an embodiment, the slots are wedged shaped. In an alternate embodiment, the slots are L-shaped. In an alternate embodiment, the slots allow for insertion of a tongued member. Examples of slots suitable for use with various embodiments of the present invention can be found in US 4,479,538.

**[0023]** Slots in mounting portion 50 and/or mounting portion 16 can generally be cut at any orientation and/or angle from the longitudinal axis of the mandrel that allows at least one first and at least one second insert to be inserted from the outermost side. In an embodiment, all of the slots in mounting portion 50 are cut at generally the same angle. Likewise, in an embodiment, all of the slots in mounting portion 16 are cut at generally the same angle. Any number of slots can be used in each of mounting portion 50 and mounting portion 16. In an embodiment, the angle of orientation of the at least one slot is greater than 10 degrees from the longitudinal axis of the mandrel. In an alternate embodiment, the angle of orientation is greater than 20 degrees from the longitudinal axis of the mandrel. In an alternate embodiment, the angle of orientation is greater than 30 degrees from the longitudinal axis of the mandrel. In an alternate embodiment, the angle of orientation is greater than 40 degrees from the longitudinal axis of the mandrel. In an alternate embodiment, the angle of orientation is greater than 50 degrees from the longitudinal axis of the mandrel. In an alternate embodiment, the angle of orientation is greater than 60 degrees from the longitudinal axis of the mandrel. In an alternate embodiment, the angle of orientation is greater than 70 degrees from the longitudinal axis of the mandrel. In an alternate embodiment, the angle of orientation is greater than 80 degrees from the longitudinal axis of the mandrel.

**[0024]** Generally, the orientation/angle and number of slots is chosen to provide 360° coverage around mounting portion 50 and/or mounting portion 16. In an alternate embodiment, 360° coverage is provided by combination of mounting portion 50 and mounting portion 16.

**[0025]** A brush insert comprising individually spring loaded pods is illustrated in Figure 5 and are more fully disclosed with reference to Figure 6.

**[0026]** Further interchangeable adaptations possible with embodiments of the present invention include interchangeable mid sections / portions located between the first insert and the second insert. Various embodiments of interchangeable housing portions include, but are not limited to, a blanking portion, a magnetic portion, a tru-gauging portion, combinations of the aforesaid, and/or the like. The embodiment in Figure 1 illustrates a magnetic housing 15 held

in place on mandrel 10 by locking dog 20, in this case, a pair of locking dogs.

**[0027]** As well, retaining sleeves of the present invention are interchangeable. In an embodiment, the lower retaining sleeve, retaining sleeve 30 in Figure 1, is interchangeable between a tapered mill profile, a top dress profile, a flow area enhancement profile and/or the like. In a tapered mill profile, a degree of taper is capable of selection relative to the desired drilling, milling, fishing, displacement, workover or well intervention operation and/or the like. As well, the upper retaining sleeve, retaining sleeve 5 in Figure 1, is also interchangeable.

**[0028]** Figure 2 is an illustration of mandrel 10 from Figure 1 without inserts, housings, or profiles. In general, at least one slot 54 is cut into of mounting portion 50 and one slot 56 is cut into mounting portion 16. Figure 2 also illustrates a hex connection 83 and a hex connection 85.

**[0029]** Now referring to Figure 3, an illustration of a cross-section of scraper blade insert 51 is disclosed. The cross-section illustrated discloses a blade 2, a tongue or foot 9, a spring loaded base 12, and wear indicator 7. Generally, insert 51 has a series of biased members or multiple biased members, such as springs and/or the like, counter-sunk into base 12. In an embodiment, foot 9 is the biased member. Insert 51 is slid into slot 54 such that the biased member is positioned between the mounting portion, or mandrel, and the insert, biasing the insert outwardly from the mandrel towards the casing. Wear indicator 7 is capable of use to indicate when insert 51 should be replaced. In various embodiments, no foot or tongue is present.

**[0030]** Now referring to Figure 4, an illustration of a spring loaded blade insert 51 is disclosed. Generally, scraper blade insert 51 is contoured generally to the shape of the mandrel such that insert 51 slides into slot 54 and/or slot 56 from Figure 2. In an embodiment, the shape of insert 51 is arcuate. The edges 53, 57, 58, and 59 of scraper blade insert 51 are generally beveled to dull the edges of the insert. Beveled edges are less likely to gouge the casing as the tool is raised and lowered in the wellbore.

**[0031]** In an embodiment, the scraper insert has blades on each side such that the scraper insert is capable of scraping a surface of the wellbore as the tool is both raised and lowered in the wellbore.

**[0032]** Now referring to Figure 5, an illustration of a spring loaded downhole tool 100 with brush inserts comprising at least one individually spring loaded pod is disclosed. Tool 100 generally comprises at least one insert 105, with a passageway therethrough, with at least one individually spring loaded pod 110, mandrel 120, profile 115, and profile 117.

**[0033]** Generally, in an embodiment, mandrel 120 is of a generally similar size and/or circumference along its length with at least three cut away portions 140, 150, and 160. Cut away portion 140 is of a sufficient depth to allow mounting of insert 105 to a mounting slot within mounting portion 102. Likewise, cut away portion 150 is of a sufficient depth to allow

mounting of insert 107 to a slot within mounting portion 104. Cut away portion 150 is an optional component and allows for interchangeable mounting of various tool enhancers, such as, but not limited to a magnetic portion, a tru-gauge portion, a flow area enhancement portion, and/or the like.

**[0034]** In an alternate embodiment, first mounting portion 102 is an enlarged portion of mandrel 120 of sufficient thickness to allow machining of a mounting slot for at least one first insert 105. Likewise, in this alternate embodiment, second mounting portion 104 is an enlarged portion of mandrel 120 of sufficient thickness to allow machining of a mounting slot for at least one second insert 107.

**[0035]** Inserts of the present invention are inserted into at least one slot cut into the mounting portions from the outermost ends and not from the center. In an embodiment, at least one insert is inserted into a slot in mounting portion from the outermost side and slid towards the center. Likewise, at least one insert is inserted into a slot in mounting portion from the outermost side and slid towards the center.

**[0036]** Slots in mounting portion 102 and/or mounting portion 104 can generally be any size desired that is capable of accepting an insert. In an embodiment, the slots are wedged shaped. In an alternate embodiment, the slots are L-shaped. In an alternate embodiment, the slots will provide the biasing member. In an alternate embodiment, the slots allow for insertion of a retaining tongue.

**[0037]** Slots in mounting portion 102 and/or mounting portion 104 can generally be cut at any orientation and/or angle from the longitudinal axis of the mandrel that allows at least one first and at least one second insert to be inserted from the outermost side. In an embodiment, all of the slots in mounting portion 102 are cut at generally the same angle. Likewise, in an embodiment, all of the slots in mounting portion 104 are cut at generally the same angle. Any number of slots can be used in each of mounting portion 102 and mounting portion 104. In an embodiment, the angle of orientation of the at least one slot is greater than 10 degrees from the longitudinal axis of the mandrel. In an alternate embodiment, the angle of orientation is greater than 20 degrees from the longitudinal axis of the mandrel. In an alternate embodiment, the angle of orientation is greater than 30 degrees from the longitudinal axis of the mandrel. In an alternate embodiment, the angle of orientation is greater than 40 degrees from the longitudinal axis of the mandrel. In an alternate embodiment, the angle of orientation is greater than 50 degrees from the longitudinal axis of the mandrel. In an alternate embodiment, the angle of orientation is greater than 60 degrees from the longitudinal axis of the mandrel. In an alternate embodiment, the angle of orientation is greater than 70 degrees from the longitudinal axis of the mandrel. In an alternate embodiment, the angle of orientation is greater than 80 degrees from the longitudinal axis of the mandrel.

**[0038]** Generally, the orientation/angle and number of slots is chosen to provide 360° coverage around mounting portion 102 and/or mounting portion 104. In an alternate embodiment, 360° coverage is provided by combination of mounting portion 102 and mounting

portion 104.

**[0039]** Further interchangeable adaptations possible with embodiments of the present invention include interchangeable housing portions (clamp) located between the first insert and the second insert. Various embodiments of interchangeable housing portions include, but are not limited to, a blanking portion, a magnetic portion, a flow area enhancement portion, combinations of the aforesaid, and/or the like. The embodiment in Figure 5 illustrates a tru-gauge clamp 125 held in place on mandrel 120 by locking dog 135, in this case, a pair of locking dogs and/or retention clamps.

**[0040]** Profiles of the present invention are interchangeable. In an embodiment, the lower profile, profile 117 in Figure 5, is interchangeable between a tapered mill profile, a top dress profile, a flow area enhancement profile and/or the like. In a tapered mill profile, a degree of taper is capable of selection relative to the desired drilling, milling, fishing, workover or any other cased hole intervention operation and/or the like. As well, the upper profile, profile 115 in Figure 5, is also interchangeable.

**[0041]** Further embodiments of the preset invention generally comprise a combination of inserts, both scraper and brush, on the same tool. In an embodiment, one mounting portion has scraper inserts and another mounting portion has brush inserts. In an alternate embodiment, a third or more mounting portion is added with any or both of brush inserts and scraper inserts.

**[0042]** Now referring to Figure 6, an illustration of a spring loaded insert 110 is disclosed. In an embodiment, insert 110 generally comprises at least one individually spring loaded wire pod 151 comprising at least one port, a insert member 111 comprising tongue or foot 114 with at least one passageway 113 extending therethrough, a biasing member 145, and a wire filament 112. Pod 151 generally encases an end of wire filament 112 wherein an end of the filament 112 is crimped over a support, such as by bending over a bar. In other embodiments, the wire may be notched and secured on a shelf or extending structure from the pod. In other embodiments, at least one of the wire filaments is bent over the support. In all embodiments with pods, the pod is biased against/from the mandrel and insert 110 is capable of floating relative to the mandrel within the slot. The mandrel and the pod are therefore the biasing members. In various embodiments, at least one passageway extends through insert member 111 for each pod 151. In various embodiments, insert member 111 is not tongued and is retained by other means, such as being wedge shaped and/or the like.

**[0043]** An embodiment of the present invention comprises a spring loaded wire brush insert positioned within the passageway of the insert and biased outwardly from the mandrel, the spring loaded wire brush insert comprising a body with at least one passageway; at least one wire filament secured at least partially within the spring loaded wire brush insert, and wherein the at least one wire filament at least partially extends through the port on the body, whereby the at least one wire filament is capable of contacting a surface of a casing. Further embodiments comprise a drill string and a housing portion, wherein the spring loaded wire

brush insert is slidingly received within a slot on a first mounting portion on the mandrel

**[0044]** In various embodiments, the insert is slidingly received from the outermost end.

**[0045]** Further embodiments secure the insert by a retaining sleeve or profile.

**[0046]** Various embodiments are assembled in various biasing arrangements. In an embodiment, the at least one pod and the at least one biasing member, such as a spring, are associated with one another. In an alternate embodiment, multiple pods are associated with one biasing member. In an alternate embodiment, multiple biasing members are associated one pod. In an alternate embodiment, multiple pods are associated with multiple biasing members.

**[0047]** Several advantages are realized by using spring loaded wire brush inserts of the present invention, such as in the case of repair, allowing for individual pod and/or brush insert replacement, allowing for varied biased members across the insert, allowing for greater casing contact in deviated section of the casing, allowing of ease of change between scraper inserts and brush inserts, allowing for float of the pod inserts and/or the wire brush inserts regardless of casing ovality/inner casing diameter variances thereby reducing and/or eliminating the occurrences of tram lines where fixed radiuses don't match up; allowing for an improved high contact system; allowing for ease of removal of brush inserts, improving safety of personnel during removal and/or changing operations, and/or the like.

**[0048]** No embodiments of the present invention comprise a first spring loaded brush insert and a second spring loaded brush insert operatively associated with the tool, wherein the spring loaded brush insert comprises a mandrel having a slot; an insert received within the slot, wherein the insert has a first section containing an opening for placing a wire filament therethrough; a spring, positioned between the mandrel and the brush insert for biasing the brush insert against the inner diameter of the casing string. All embodiments of brush inserts the present invention comprise at least one individually spring loaded pod or spring loaded insert for enhanced casing cleaning.

**[0049]** Figure 7 is an illustration of a pod-loaded insert 175 comprising at least one individually spring loaded pod 176, spring loaded brush insert 178, tongued insert/biasing member 183, and access passageway 181. The fixed blade will be secured to the mandrel in combination with the slot profile and blade profile. The spring loaded pods will be retained within correlating blade profiles and act independently to the blade. The spring mechanism in combination with the wire pod will be operable and secured within the bored sections of the blade. The wire filaments will be secured to the pod housing by means of a positive locking system. The wire strands, composing of the wire filament, will be folded, twisted, and/or crimped to reduce wire fatigue and improve casing wall contact and/or cleaning. The wire extension, beyond the blade outer diameter, will remain short, rigid, and/or abundant thus providing for an enhanced casing inner diameter cleaning.

**[0050]** Figure 8 is an illustration of an embodiment of a profile 250 with a gradual tapered mill. Taper 252 can be varied as desired. Profile 250 is secured to a mandrel by any means common in the art. In an embodiment, a retaining key locking feature is used to secure the retaining sleeve. In an embodiment of the locking feature, a locking mechanism will be inserted and isolated within the mounting region. In various embodiments, the retaining key locking feature is locking dogs, retaining keys 254, ball(s) 253, locking wire, screw, bolts, threaded connection, fastener, interference fit, and/or the like. In an embodiment, the retaining device(s) are capable of providing the tensile and compressional resistance necessary to secure the various inserts in the slots during drilling operations. Accordingly, the profiles of the present invention secure the various inserts in the slots.

**[0051]** In various embodiments, an additional locking mechanism, or profile, will be positioned to secure the retaining sleeve torsionally thus not allowing the sleeve to rotate opposite the mandrel. In an embodiment, the retaining sleeves will be positioned over the undercuts in the mandrel. In an alternate embodiment, the retaining sleeve is held in place by alternate means, such as, but not limited to a screw thread, at least one bolt, a pin, a hex fitting, a bearing, a gear, a spline, and/or the like. Generally, any method common in the art can be used to secure the sleeve to the mandrel.

**[0052]** In an embodiment, the undercuts will accept two stainless (or similar material) split halves with the locking profile machined to coincide with the retainer sleeve locking profile. Once aligned, the locking mechanism(s) are capable of being inserted, thus locking the two components together. These split halves are designed to be interchangeable and used to preserve the mandrel integrity and life.

**[0053]** Figure 9 is an illustration of a top dress tapered mill profile 270 with a taper 272.

**[0054]** Figure 10 is an illustration of a sharp tapered mill profile 280. The taper 282 is less than that of Figure 8, thereby illustrating that a taper of a profile on a retaining sleeve of the present invention can be modified.

**[0055]** Figure 11 is an illustration of a magnetic housing portion 200. In the embodiment illustrated in Figure 1, housing portion 200 is secured in cut away portion 70 by locking dog(s) 210. Referring back to Figure 11, housing portion 200 has ports for accepting the locking dogs. The locking dogs will prevent and/or resist rotation of the housing portion. In this embodiment, magnetic bars 220 are slid into carriers/slots on portion 200.

**[0056]** A housing portion of the present invention is generally a sheet of material or materials that is wrapped around the mandrel. The sheet can be secured by any means common in the art, such as, but not limited to bolting, welding, screwing, stabbing, and/or the like.

**[0057]** The embodiment in Figure 11 comprises magnetic portions. The magnetic portion can be added by any means. The magnetic portion can be used to remove metallic debris from the wellbore, thereby reducing the amount of metallic material in the drilling, completion, and/or

wellbore fluid and increasing and/or improving the service life and condition of those fluids, tools, subsequent wellbore activities and/or the like.

**[0058]** Figure 12 is an illustration of a tru-gauge housing portion 300. The tru-gauge is a positive casing drill and/or gauging device used to simulate other downhole equipment and/or jewelry to be utilized or deployed in the casing and/or the wellbore on subsequent well intervention runs.

**[0059]** Figure 13 is an illustration of a blanking housing portion 400. The illustration of blanking housing portion 400 provides an alternate/additional means of securing the sheet, such that a bar or key 440 can be used to connect the opposing ends of the sheet of the housing portion.

**[0060]** In an embodiment, the blanking housing provides protection to the mandrel should no other mid section option be utilized.

**[0061]** Figure 14 discloses an alternate embodiment of a profile and insert locking mechanism. In general, a cut-away portion 140 and/or cut-away portion 160 from Figure 5 has a geometrical shaped surface and profile retainer 505 has a complimentary geometrically shaped interior surface such that retainer 505 locks does not rotate when when inserted into place. Ribs or gears 520 cooperate with an interior surface of profile 530 to resist rotation. Further locking of profile 530 can be achieved with the use of a bearing system 510. In various embodiments, gaskets 500 are used to prevent or inhibit drilling fluid or other fluid from passing between profile 530 and retainer 505.

**[0062]** Figure 15 is an illustration of a spring loaded insert 600 capable of use in various embodiments of the present invention. Passageway 610 is elongated along a base of insert 600. Cut-out 620 extend through insert 600 as is better seen with reference to Figure 16. Generally, Figure 16 illustrates passageway 610 is tapered such that when a wire brush insert as disclosed in Figure 17 is inserted into passageway 610 the taper does not allow the wire brush insert to pass through passageway 610. The taper can be gradual, arcuate, shelf like, or generally any other taper common in the art and capable of resisteing the wire brush insert from passing through spring loaded insert 610.

**[0063]** Cut-out 620 is generally any shape capable of allowing a biasing member to bias the mandrel and a wire brush insert. In an embodiment, a circular wound spring is used and cut-out 620 is generally circular in shape extending at least a portion of the distance through insert 600, but not through insert 600.

**[0064]** Figure 17 discloses a wire brush insert 700 capable of use with embodiments of the present invention comprising a base 730 and at least one wire filament 710. Generally, any method of securing wire filaments 710 within insert 700 is capable of use in various embodiments. In an embodiment, wire filament 710 is secured in insert 700 by crimping of insert 700 such that insert 700 is tapered inwardly from base 730 in at least portion 720.

Generally, any manner of securing wire filament 710 is capable of use.

**[0065]** Also disclosed are methods of cleaning a wellbore comprising the steps of lowering or raising a drill string comprising at least one spring loaded wellbore cleaning tool into a wellbore to at least one section of casing that needs cleaning, the tool comprising at least one spring loaded brush insert as herein disclosed; and, cleaning the at least one section by rotating the drill string, whereby each of the at least one spring loaded pods is biased outwardly from the mandrel towards the at least one section of casing wherein the at least one section of casing is brushed. Further embodiments comprise a step of scraping the at least one section of casing. Further embodiments comprise a step of magnetically attracting metallic debris within the at least one section of casing. Further embodiments comprise the step of centering the tool within the wellbore.

**[0066]** Further embodiments comprise the step of circulating a drilling fluid through the inner diameter of the work string.

**[0067]** Methods and apparatuses of the present invention are particularly useful in drill strings with deviated sections. However, a tool of the present invention will work in any wellbore, deviated or not.

**[0068]** As such, embodiments of the present invention are particularly meant to cover a wellbore cleaning tool comprising a mandrel connected to a drill string, said mandrel comprising; at least a first insert with a passageway therethrough; at least a second insert; and, a housing portion, wherein at least said first insert comprises a spring loaded brush insert with a passageway therethrough, wherein said spring loaded brush insert is biased outwardly with a biasing member from said mandrel, and further wherein said first insert and said second insert are slidably received within a slot on a first mounting portion on said mandrel and a slot on a second mounting portion on said mandrel, from the outermost respective ends, and wherein said first insert is secured by a first retaining sleeve and said second insert is secured by a second retaining sleeve; a spring loaded wellbore cleaning tool comprising a mandrel connected to a drill string; at least a first insert with a passageway therethrough; at least a second insert; and, a mid housing portion, wherein said first insert is selected from at least one of a scraper insert for scraping a surface of at least one section of casing and at least one spring loaded brush insert selected from a spring loaded pod and a spring loaded wire brush insert, and further wherein said first insert and said second insert are slidably received within a slot on a first mounting portion on said mandrel and a slot on a second mounting portion on said mandrel, from the outermost respective ends, and wherein said first insert is secured by a first retaining sleeve and said second insert is secured by a second retaining sleeve, wherein said spring loaded brush insert is biased against the mandrel; a spring loaded brush insert comprising at least one individually spring loaded pod comprising a body with at least one passageway and at least one wire filament secured at least partially within said body and extending through said passageway; and, at least one insert member with at least one passageway extending therethrough wherein said pod is biased outwardly from said mandrel and further wherein said at least one wire filament is capable of contacting a surface of a

casing; and, a method of cleaning a wellbore comprising the steps of lowering, raising or rotating a drill string comprising at least one springy loaded wellbore cleaning tool into a wellbore to at least one section of casing that needs cleaning, said tool comprising at least one brush insert comprising a spring loaded brush insert selected from a spring loaded pod and a spring loaded wire brush insert; and, cleaning said at least one section by rotating said drill string, whereby said spring loaded pod is biased outwardly from the bottom portion of the blade towards said at least one section of casing wherein said at least one section of casing is brushed.

**[0069]** While a particular embodiment of the invention has been shown and described, numerous variations and alternate embodiments will occur to those skilled in the art. Accordingly, it is intended that the invention be limited only in terms of the appended claims.

## **REFERENCES CITED IN THE DESCRIPTION**

This list of references cited by the applicant is for the reader's convenience only. It does not form part of the European patent document. Even though great care has been taken in compiling the references, errors or omissions cannot be excluded and the EPO disclaims all liability in this regard.

### **Patent documents cited in the description**

- [US6464010B \[0001\]](#)
- [US4479538A \[0022\]](#)

**Patentkrav****1. Borehulsrengøringsværktøj (100)**

der omfatter: en dorn, hvilken dorn

(120) omfatter;

5 mindst en første indsats (105) med en passage

derigennem; mindst en anden indsats (107); og en

husdel, kendetegnet ved, at

mindst den første indsats omfatter uafhængigt fjederbelastede børsteindsatser, der

omfatter hylstre (110) med en passage (113) derigennem, hvor den fjederbelastede

10 børsteindsats forspændes udadtil med et forspændingselement (145) fra dornen, og

hvor den første indsats og den anden indsats endvidere modtages glidende inde i en

slidse på en første monteringsdel (102) på dornen og en slidse på en anden

monteringsdel (104) på dornen fra de respektive yderste ender, og hvor den første

indsats er fastgjort med en første fastholdelseskappe (115), og den anden indsats er

15 fastgjort med en anden fastholdelseskappe (117).

**2. Borehulrengøringsværktøj ifølge krav 1, der endvidere omfatter en tredje monteringsdel og/eller et andet værktøj.**

20 **3. Borehulrengøringsværktøj ifølge krav 1 eller krav 2, hvor den anden indsats er en skrabeindsats (51).**

**4. Borehulrengøringsværktøj ifølge krav 3, hvor skrabeindsatsen er i stand til at skrabe en overflade af borehullet, samtidig med at værktøjet er én eller flere af hævet, sænket og/eller roteret i borehullet.**

**5. Borehulrengøringsværktøj ifølge et hvilket som helst af kravene 1-4, der endvidere omfatter en klemmedel (125), som er lokaliseret mellem den første og den anden indsats, hvor klemmedelen er valgt blandt mindst én af en magnetisk del, en**

30 **målnøjagtig del og en slukningsdel.**

**6. Borehulrengøringsværktøj ifølge et hvilket som helst af kravene 1-3, hvor de fjederbelastede hylstre omfatter mindst ét trådfilament (112), som mindst delvis er**

fastgjort inde i det fjederbelastede hylster.

7. Borehulrengøringsværktøj ifølge et hvilket som helst af kravene 1-6, hvor borehulrengøringsværktøjet er forbundet med en borestreng.

5

8. Fremgangsmåde til rengøring af et borehul, hvilken fremgangsmåde omfatter følgende trin:

sænkning, hævning eller rotation af en borestreng, der omfatter mindst ét fjederbelastet borehulrengøringsværktøj, i et borehul til mindst ét indkapslingsafsnit, der har behov for rengøring, hvilket værktøj omfatter mindst én børsteindsats, der er fastgjort inde i en skovl, idet den mindst ene børsteindsats omfatter uafhængige fjederbelastede hylstre; og rengøring af det mindst ene afsnit ved rotation af borestrengen, hvorved de fjederbelastede hylstre forspændes udadtil fra en nederste del af skovlen mod det mindst ene indkapslingsafsnit, hvor det mindst ene indkapslingsafsnit afbørstes.

10

15

9. Fremgangsmåde ifølge krav 8, der endvidere omfatter ét eller flere af følgende trin:

- a) trinnet med skrabning af mindst ét indkapslingsafsnit;
- b) trinnet med magnetisk tiltrækning af metalrester inde i det mindst ene indkapslingsafsnit og/eller
- c) trinnet med centrering af værktøjet inde i borehullet.

20

10. Fjederbelastet børsteindsats til montering på en dorn, hvilken fjederbelastede

børsteindsats omfatter:

25

mindst ét individuelt fjederbelastet hylster (110), der omfatter en krop med mindst én passage (113) og mindst ét trådfilament (112), som mindst delvis er fastgjort inde i kroppen og strækker sig gennem passagen; og mindst ét indsatsselement (105) med mindst én passage, der strækker sig derigennem, hvor hylsteret forspændes udadtil fra dornen, og endvidere hvor det mindst ene trådfilament er i stand til at komme i kontakt med en overflade af en indkapsling.

30

**11.** Børsteindsats ifølge krav 10, der endvidere omfatter en dorn (120), som er forbundet med en borestreng; en husdel, hvor den fjederbelastede børsteindsats modtages glidende inde i en slidse på en første monteringsdel (102) på dornen.

5 **12.** Børsteindsats ifølge krav 11, hvor børsteindsatsen modtages glidende fra en yderste ende af slidsen, og/eller børsteindsatsen er fastgjort med en fastholdelseskappe (115).

10 **13.** Børsteindsats ifølge et hvilket som helst af kravene 10-12, hvor det mindst ene hylster og det mindst ene forspændte element er forbundet med hinanden, hvor børsteindsatsen endvidere omfatter multiple hylstre, og børsteindsatsen er sammennotet.

**DRAWINGS**

**FIG. 1**

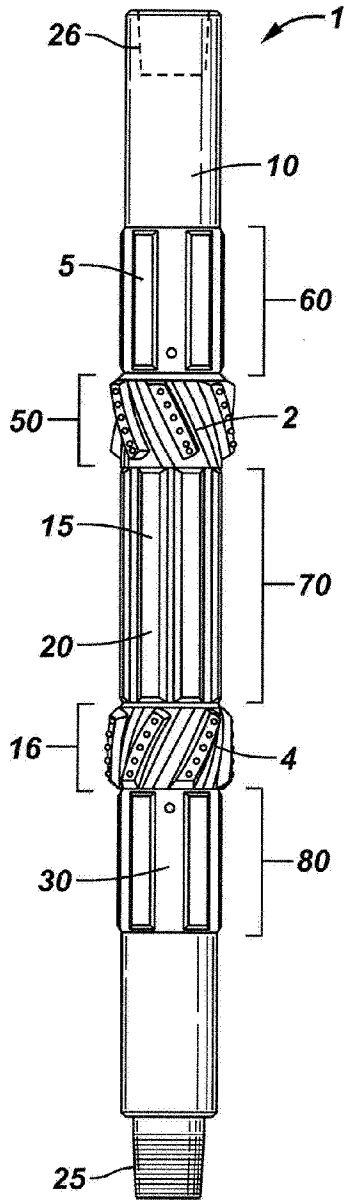

**FIG. 2**

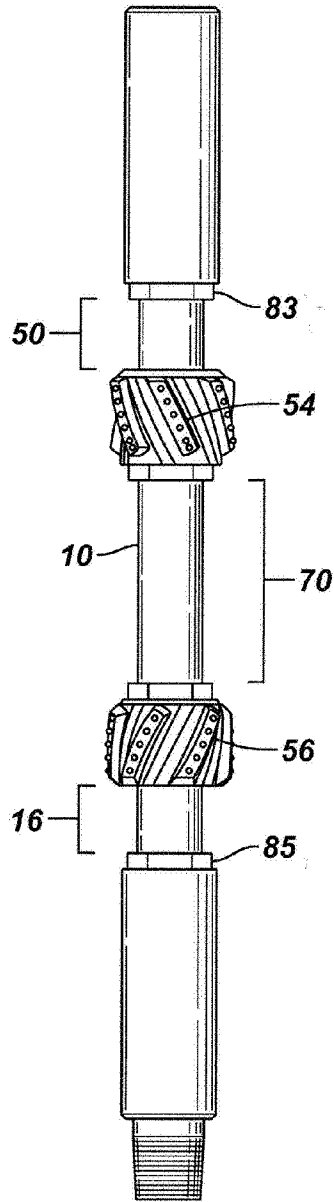

**FIG. 3**

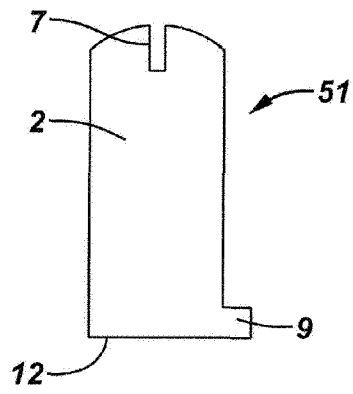

**FIG. 4**

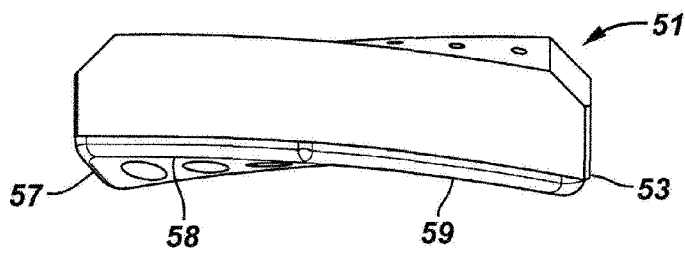

FIG. 5

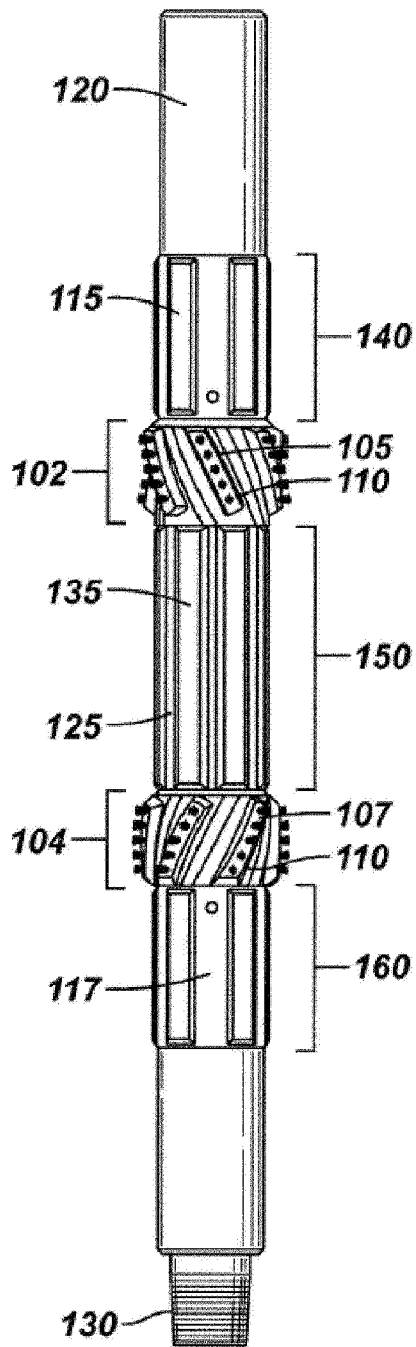

FIG. 6

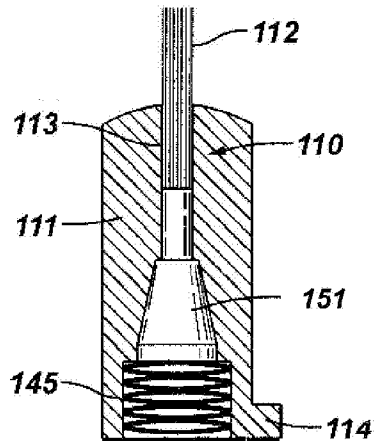

FIG. 7

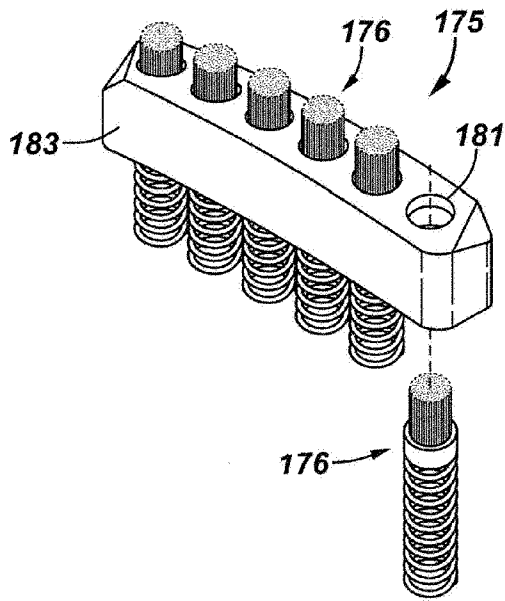

FIG. 8

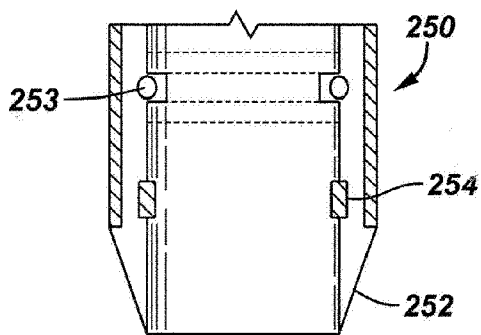

FIG. 9

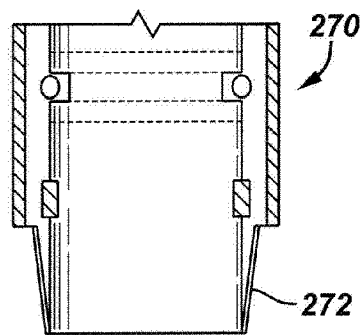

FIG. 10

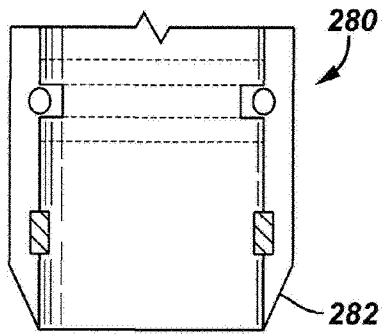

FIG. 11

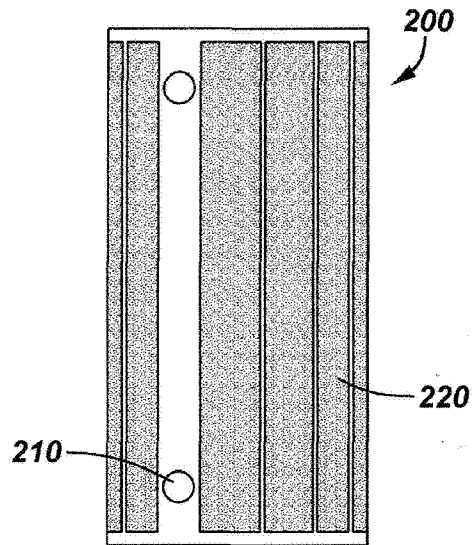

FIG. 12

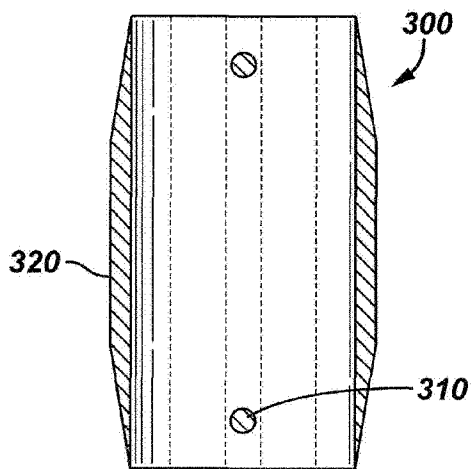
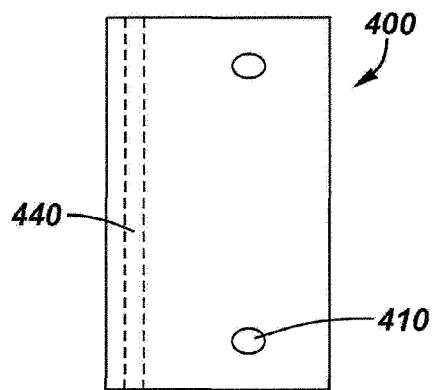
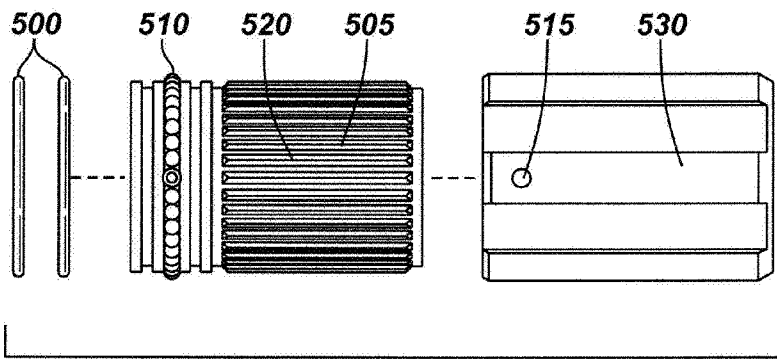

FIG. 13



**FIG. 14**



**FIG. 15**

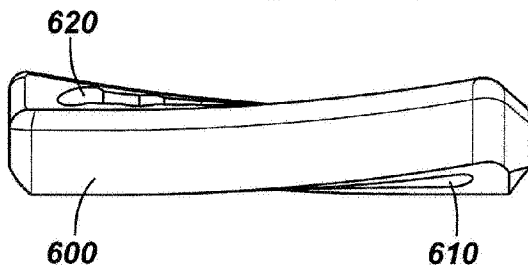

FIG. 16

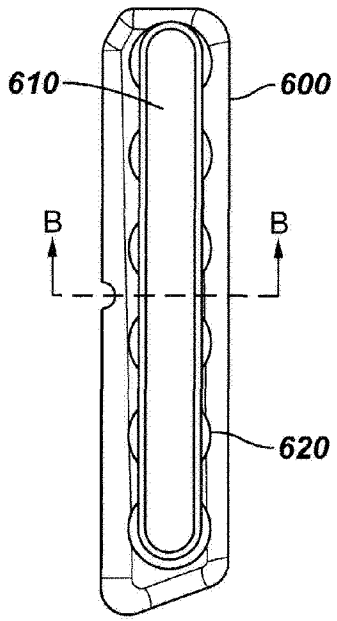

FIG. 17

