

(19) World Intellectual Property Organization  
International Bureau



(43) International Publication Date  
3 January 2003 (03.01.2003)

PCT

(10) International Publication Number  
**WO 03/001845 A1**

- (51) International Patent Classification<sup>7</sup>: **H04R 25/00**
- (21) International Application Number: PCT/SE02/01088
- (22) International Filing Date: 6 June 2002 (06.06.2002)
- (25) Filing Language: Swedish
- (26) Publication Language: English
- (30) Priority Data:  
0102207-8                      21 June 2001 (21.06.2001)    SE
- (71) Applicant (for all designated States except US): **P & B RESEARCH AB** [SE/SE]; Splintvedsgatan 7, S-416 80 Göteborg (SE).
- (72) Inventor; and
- (75) Inventor/Applicant (for US only): **WESTERKULL, Patrick** [SE/SE]; Hovås Hagstig 26A, S-436 54 Hovås (SE).
- (74) Agent: **WESTERKULL, Patrik**; Entific Medical Systems AB, Box 16024, S-412 21 Göteborg (SE).
- (81) Designated States (national): AE, AG, AL, AM, AT, AU, AZ, BA, BB, BG, BR, BY, BZ, CA, CH, CN, CO, CR, CU, CZ, DE, DK, DM, DZ, EC, EE, ES, FI, GB, GD, GE, GH, GM, HR, HU, ID, IL, IN, IS, JP, KE, KG, KP, KR, KZ, LC, LK, LR, LS, LT, LU, LV, MA, MD, MG, MK, MN, MW, MX, MZ, NO, NZ, OM, PH, PL, PT, RO, RU, SD, SE, SG, SI, SK, SL, TJ, TM, TN, TR, TT, TZ, UA, UG, US, UZ, VN, YU, ZA, ZM, ZW.
- (84) Designated States (regional): ARIPO patent (GH, GM, KE, LS, MW, MZ, SD, SL, SZ, TZ, UG, ZM, ZW), Eurasian patent (AM, AZ, BY, KG, KZ, MD, RU, TJ, TM), European patent (AT, BE, CH, CY, DE, DK, ES, FI, FR, GB, GR, IE, IT, LU, MC, NL, PT, SE, TR), OAPI patent (BF, BJ, CF, CG, CI, CM, GA, GN, GQ, GW, ML, MR, NE, SN, TD, TG).

[Continued on next page]

(54) Title: A COUPLING DEVICE FOR A TWO-PART BONE-ANCHORED HEARING AID APPARATUS

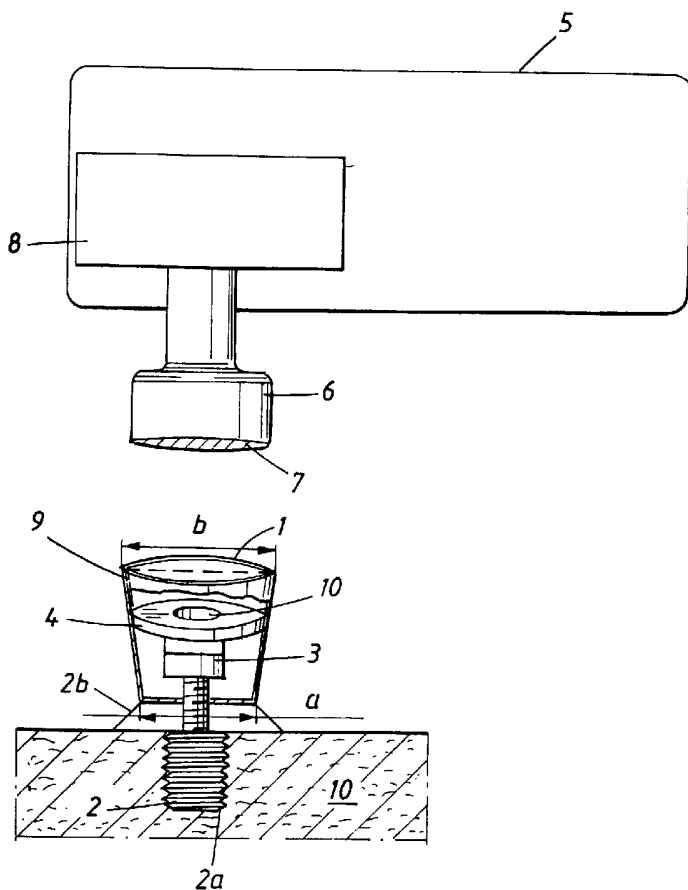

(57) Abstract: The present invention relates to a coupling device for attaching the external hearing aid part (5) to the skull bone 810) anchored part in a bone conducting hearing aid apparatus, whereby the retaining force in the coupling device is substantially established by means of a permanent magnet. The bone anchored part as well as the external hearing aid part (5) comprises a magnetic part (4 and 6, respectively) and at least one of these magnetic parts is a permanent magnet. If only one of the two magnetic parts (4, 6) is a permanent magnet, the other magnetic part should be made of a ferro-magnetic material. The magnetic part (4) of the bone anchored part of the hearing aid is preferably made as an annular device located in the skin penetrating spacer (1) of the hearing aid.

WO 03/001845 A1



**Published:**

— *with international search report*

*For two-letter codes and other abbreviations, refer to the "Guidance Notes on Codes and Abbreviations" appearing at the beginning of each regular issue of the PCT Gazette.*

## A COUPLING DEVICE FOR A TWO-PART BONE-ANCHORED HEARING AID APPARATUS

5 The present invention relates to a coupling device for attaching the external hearing aid part to the skull bone anchored part in a bone conducting hearing aid apparatus.

10 For persons who cannot benefit from traditional, air conduction hearing aids there are other types of sound transmitting hearing aids on the market, i e bone anchored hearing aids which mechanically transmit the sound information to a persons inner ear via the skull bone by means of a vibrator. The hearing aid device is connected to an anchoring element in the form of an implanted titanium screw  
15 installed in the bone behind the external ear and the sound is transmitted via the skull bone to the cochlea (inner ear), i e the hearing aid works irrespective of a disease in the middle ear or not. The bone anchoring principle means that the skin is penetrated which makes the  
20 vibratory transmission very efficient.

This type of hearing aid device has been a revolution for the rehabilitation of patients with certain types of impaired hearing. It is very convenient for the patient and  
25 almost invisible with normal hair styles. It can easily be connected to the implanted titanium fixture by means of a bayonet coupling or a snap in coupling. Examples of this type of hearing aid devices are described in US Patents No. 4,498,461 and 5,735,790. It is also referred to the  
30 BAHA<sup>®</sup> bone anchored hearing aid marketed by Entific Medical Systems in Göteborg.

The previously known coupling devices for said hearing aids are all based on mechanically spring actuated parts.  
35 The disadvantage with such coupling details is the fact that they are exposed to mechanical wear so that in course of time there is a play in the system and other troubles when connecting the hearing aid device.

One object of the present invention is to provide a coupling device for a hearing aid apparatus which is less exposed to mechanical wear compared to the previously known coupling devices with mechanically spring actuated parts.

According to the invention, the retaining force in the coupling device is substantially established by means of a permanent magnet.

According to a preferred embodiment the bone anchored part as well as the hearing aid device itself comprises a magnetic part and at least one of these magnetic parts is a permanent magnet.

In the following the invention will be described more in detail with reference to the accompanying drawing in which a bone anchored hearing aid with a coupling device according to the invention is schematically illustrated.

The figure shows the two main parts of the hearing aid apparatus, the bone anchored part and the hearing aid part which is intended to be connected to the bone anchored part. The bone anchored part comprises a skin penetrating spacer 1 which is attached by means of a connecting screw 3 to an anchoring element, a fixture 2, anchored in the skull bone 10. The fixture is preferably made of titanium which has a known ability to integrate into surrounding bone tissue, so-called osseointegration. The fixture has a main body 2a with external threads to be inserted into the skull bone, a flange 2b which functions as a stop means when the fixture is installed into the skull bone 10 and a tool engaging socket, for instance in the form of an external hex (not shown here). The main body 2a is shorter than 5 mm, in order not to go completely through the thin skull bone. One example of such a fixture is illustrated in US Des. 294,295.

The apical part of the main body 2a of the fixture can be designed with cutting edges which are self-tapping when the anchoring element is installed into a hole drilled in the bone with a hole diameter corresponding to the inner diameter of the screw thread profile. One example of such a fixture is described in Swedish patent application 0002627-8.

The skin penetrating spacer 1 comprises an annular magnetic part 4 so that the connecting screw 3 can be easily reached in the center 4a. As an alternative the magnetic part 4 can be detachable so that the connecting screw 3 can be reached in this way. As a further alternative the magnetic part can be integral with the connecting screw so that they are disengaged together.

Preferably the skin penetrating spacer has a conical form so that the spacer part adjacent to the fixture has a smaller diameter at the base compared to the upper diameter b of the spacer. In such a way the contact surface of the magnetic part 4 can be made larger without a corresponding increase of the diameter at the base of the spacer.

The hearing aid part 5 also comprises a magnetic part 6 having a magnetic surface 7 for attaching to the corresponding magnetic part 4 of the skin penetrating spacer. The magnetic contact surface 7 is mechanically connected to the vibrator 8 in the hearing aid part. The hearing aid part with the vibrator and other electronics can be of a type which is known per se and will therefore not be described in any detail here.

At least one of the two magnetic parts 4 and 6 in the skin penetrating spacer and the hearing aid part, respectively, should contain a permanent magnet. In case of a permanent magnet in only one of said magnetic parts, the other part should then be made of a ferro-magnetic material. The mag-

nets as well as the ferro-magnetic material should be surface treated in order to avoid corrosion on the surfaces of these magnetic materials.

5 Sintered magnets usually have stronger magnetic properties than other types of magnets, so therefore it could be an advantage to use such type of magnets for a good retention of the hearing aid and a possible reduction of the size of the magnetic coupling device.

10

To facilitate the connection of the external hearing aid part 5 the skin penetrating spacer is provided with an annular flange or central boss which projects outwards from the magnetic contact surface to prevent the hearing aid  
15 from sliding off the magnetic surface in a lateral direction. As an alternative such a flange or central boss could be arranged on the magnetic coupling part 6 on the hearing aid part 5.

20 In the example illustrated in the figure the skin penetrating spacer 1 and the fixture 2 are illustrated as two separate parts which are attached to each other by means of a connecting screw 3. As an alternative the spacer and the fixture can be made in one piece in which case no connecting  
25 screw is required. In this case the magnetic part can be integral with this one piece or it can be made as a replaceable piece.

30

35

## CLAIMS

1. Coupling device for attaching the external hearing aid part to the skull bone anchored part in a bone conducting hearing aid apparatus characterized in that the retaining force in the coupling device is substantially established by means of a permanent magnet.
2. Coupling device according to claim 1 characterized in that the bone anchored part as well as the hearing aid device (5) itself comprises a magnetic part (4 and 6, respectively) and at least one of these magnetic parts is a permanent magnet.
3. Coupling device according to claim 2 characterized in that in case of a permanent magnet in only one of the magnetic parts (4,6), the other part should then be made of a ferro-magnetic material.
4. Coupling device according to claim 2 characterized in that the magnetic part (4) of the bone anchored part of the hearing aid comprises an annular part arranged in the skin penetrating spacer (1) of the hearing aid.
5. Coupling device according to claim 4 characterized in that the magnetic part (4) of the bone anchored part of the hearing aid is integral with the connecting screw (3) which connects the skin penetrating spacer (1) with the hearing aid anchoring screw, the fixture (2).
6. Coupling device according to claim 2 characterized in that the skin penetrating spacer (1) and the hearing aid anchoring screw, the fixture (2), is made in one piece so that the magnetic part (4) is integral with this detail.

7. Coupling device according to claim 2 characterized in that the magnetic part (4) of the bone anchored part of the hearing aid is replaceable by snap-in or screw retaining means in the skin penetrating spacer (1).

8. Coupling device according to claim 2 characterized in that the permanent magnet is made by means of sintering technique.

9. Coupling device according to claim 2 characterized in that the magnetic material has a non-corrosive surface layer material.

10. Coupling device according to claim 4 characterized in that the magnetic part (4) of the bone anchored part of the hearing aid is disposed in the skin penetrating spacer (1) in such a way that at least a part of the skin penetrating spacer projects outwards from the magnetic contact surface (7).

11. Coupling device according to claim 4 characterized in that the diameter (a) of the skin penetrating spacer (1) adjacent to the skull bone (10) is smaller compared to the diameter (b) of that part of the skin penetrating spacer which is located close to the hearing aid part (5).

30

35



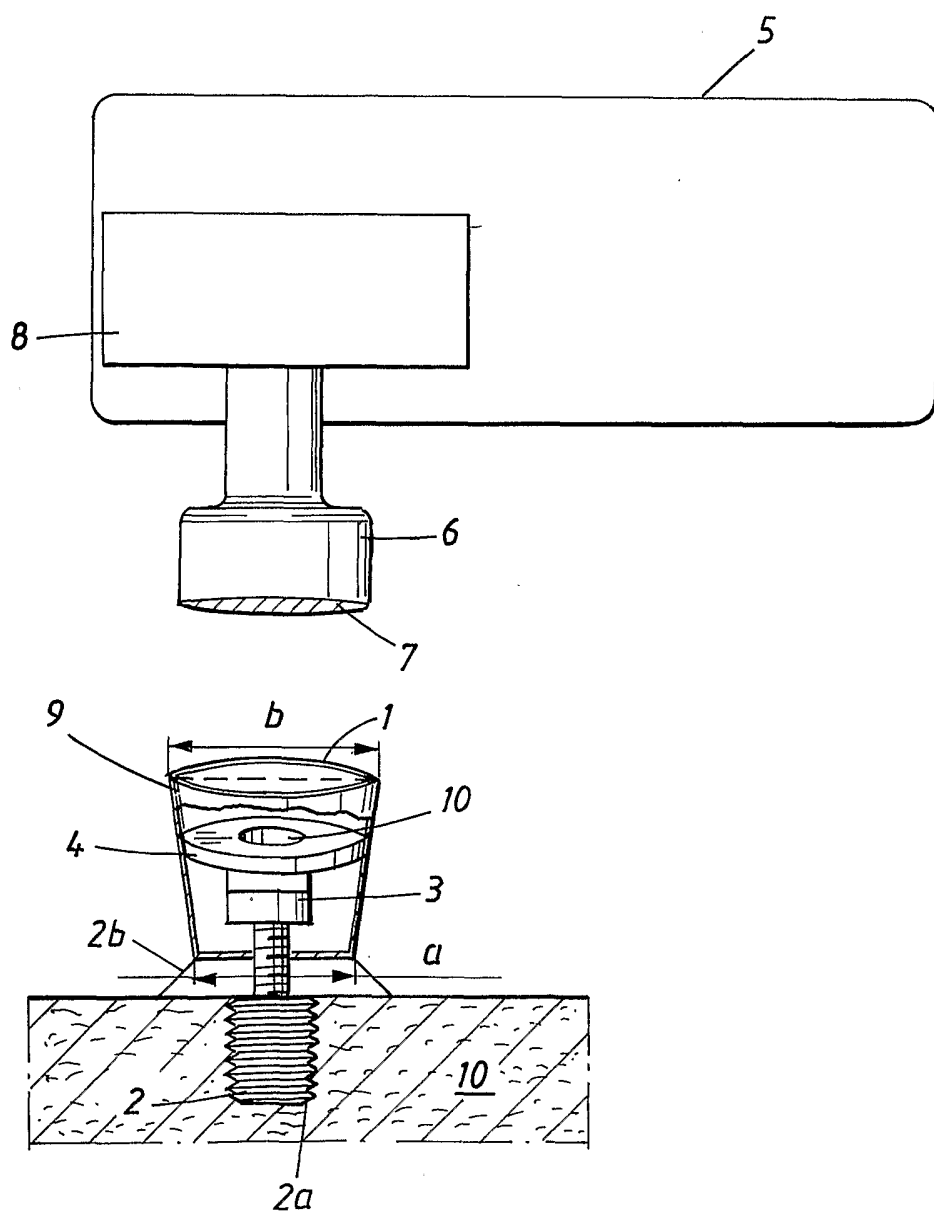

## INTERNATIONAL SEARCH REPORT

International application No.

PCT/SE 02/01088

## A. CLASSIFICATION OF SUBJECT MATTER

IPC7: H04R 25/00

According to International Patent Classification (IPC) or to both national classification and IPC

## B. FIELDS SEARCHED

Minimum documentation searched (classification system followed by classification symbols)

IPC7: H04R, A61F

Documentation searched other than minimum documentation to the extent that such documents are included in the fields searched

SE,DK,FI,NO classes as above

Electronic data base consulted during the international search (name of data base and, where practicable, search terms used)

EPO-INTERNAL, WPI DATA

## C. DOCUMENTS CONSIDERED TO BE RELEVANT

Category*	Citation of document, with indication, where appropriate, of the relevant passages	Relevant to claim No.
X	US 4612915 A (J.V.D. HOUGH ET AL), 23 Sept 1986 (23.09.86), column 5, line 37 - line 41; column 6, line 27 - line 49, figure 6 --	1-11
X	US 4957478 A (A.J. MANIGLIA), 18 Sept 1990 (18.09.90), column 10, line 31 - line 57; column 12, line 50 - line 61, "positioning magnets"76, 78 in fig. 5 and 15 --	1-3
X	US 5015224 A (A.J. MANIGLIA), 14 May 1991 (14.05.91), column 10, line 35 - line 61; column 12, line 55 - line 66, "positioning magnets"76, 78 in fig. 5 and 15 --	1-3

 Further documents are listed in the continuation of Box C. See patent family annex.

\* Special categories of cited documents:

"A" document defining the general state of the art which is not considered to be of particular relevance

"E" earlier application or patent but published on or after the international filing date

"L" document which may throw doubts on priority claim(s) or which is cited to establish the publication date of another citation or other special reason (as specified)

"O" document referring to an oral disclosure, use, exhibition or other means

"P" document published prior to the international filing date but later than the priority date claimed

"T" later document published after the international filing date or priority date and not in conflict with the application but cited to understand the principle or theory underlying the invention

"X" document of particular relevance: the claimed invention cannot be considered novel or cannot be considered to involve an inventive step when the document is taken alone

"Y" document of particular relevance: the claimed invention cannot be considered to involve an inventive step when the document is combined with one or more other such documents, such combination being obvious to a person skilled in the art

"&amp;" document member of the same patent family

Date of the actual completion of the international search

19 Sept 2002

Date of mailing of the international search report

01-10-2002

Name and mailing address of the ISA/

Swedish Patent Office

Box 5055, S-102 42 STOCKHOLM

Facsimile No. +46 8 666 02 86

Authorized officer

Leif Vingård / MRo

Telephone No. +46 8 782 25 00

## INTERNATIONAL SEARCH REPORT

International application No.

PCT/SE 02/01088

## C (Continuation). DOCUMENTS CONSIDERED TO BE RELEVANT

Category*	Citation of document, with indication, where appropriate, of the relevant passages	Relevant to claim No.
A	US 5217011 A (M.E. BISCH), 8 June 1993 (08.06.93), column 3, line 5 - line 44, magnet 36, fig. 1  ---	1-3
A	US 6171229 B1 (K. KROLL ET AL), 9 January 2001 (09.01.01), magnets 105, 110, fig. 1-5, text  -- -----	1-3

INTERNATIONAL SEARCH REPORT

Information on patent family members

02/09/02

International application No.

PCT/SE 02/01088

Patent document cited in search report	Publication date	Patent family member(s)	Publication date
US 4612915 A	23/09/86	AU 593251 B	08/02/90
		AU 5780386 A	27/11/86
		BE 904809 A	15/09/86
		CA 1251274 A	14/03/89
		DE 3617089 A	27/11/86
		DK 238086 A	24/11/86
		ES 555252 A	16/07/87
		ES 8707067 A	16/09/87
		FR 2582216 A,B	28/11/86
		GB 2176078 A,B	10/12/86
		GB 8610605 D	00/00/00
		IL 78724 A	21/06/92
		IT 1189678 B	04/02/88
		IT 8667425 D	00/00/00
		JP 1839181 C	25/04/94
		JP 5052747 B	06/08/93
		JP 61273100 A	03/12/86
		NL 8601286 A	16/12/86
		SE 468374 B,C	21/12/92
		SE 8602251 A	24/11/86
US 4957478 A	18/09/90	US 5015224 A	14/05/91
US 5015224 A	14/05/91	US 4957478 A	18/09/90
US 5217011 A	08/06/93	NONE	
US 6171229 B1	09/01/01	NONE	