

(19) World Intellectual Property Organization  
International Bureau



(43) International Publication Date  
27 April 2006 (27.04.2006)

PCT

(10) International Publication Number  
**WO 2006/044641 A2**

- (51) International Patent Classification: Not classified
- (21) International Application Number:  
PCT/US2005/036992
- (22) International Filing Date: 13 October 2005 (13.10.2005)
- (25) Filing Language: English
- (26) Publication Language: English
- (30) Priority Data:  
60/619,087 15 October 2004 (15.10.2004) US  
60/707,623 12 August 2005 (12.08.2005) US
- (71) Applicants (for all designated States except US): **DONNELLY CORPORATION** [—/US]; 414 East Fortieth Street, Holland, Michigan 49423-5368 (US). **CLARION TECHNOLOGIES, INC.** [—/US]; 38 West Fulton, Suite 300, Grand Rapids, Michigan 49503 (US).
- (72) Inventors; and
- (75) Inventors/Applicants (for US only): **PICKEN, Alan, D.** [US/US]; 2150 Hickory Ridge, Milford, Michigan 48380 (US). **BECKMAN, William** [US/US]; 2021 Lakeway Drive, Holland, Michigan 49423 (US). **NESTELL, David, E.** [US/US]; 18427 Fruitport Road, Spring Lake, Michigan 49456 (US). **REPP, R., Scott** [US/US]; 17170 Eighth Street, Holland, Michigan 49424 (US). **SCHROEDER, Kevin, J.** [US/US]; 4794 Country Ridge Court, Holland, Michigan 49423 (US).
- (74) Agent: **VAN DYKE, GARDNER, LINN & BURKHART, LLP**; c/o Timothy A. Flory, 2851 Charlevoix Drive SE, P.O. Box 888695, Grand Rapids, Michigan 49588-8695 (US).
- (81) Designated States (unless otherwise indicated, for every kind of national protection available): AE, AG, AL, AM, AT, AU, AZ, BA, BB, BG, BR, BW, BY, BZ, CA, CH, CN, CO, CR, CU, CZ, DE, DK, DM, DZ, EC, EE, EG, ES, FI, GB, GD, GE, GH, GM, HR, HU, ID, IL, IN, IS, JP, KE, KG, KM, KP, KR, KZ, LC, LK, LR, LS, LT, LU, LV, LY, MA, MD, MG, MK, MN, MW, MX, MZ, NA, NG, NI, NO, NZ, OM, PG, PH, PL, PT, RO, RU, SC, SD, SE, SG, SK, SL, SM, SY, TJ, TM, TN, TR, TT, TZ, UA, UG, US, UZ, VC, VN, YU, ZA, ZM, ZW.
- (84) Designated States (unless otherwise indicated, for every kind of regional protection available): ARIPO (BW, GH, GM, KE, LS, MW, MZ, NA, SD, SL, SZ, TZ, UG, ZM, ZW), Eurasian (AM, AZ, BY, KG, KZ, MD, RU, TJ, TM), European (AT, BE, BG, CH, CY, CZ, DE, DK, EE, ES, FI, FR, GB, GR, HU, IE, IS, IT, LT, LU, LV, MC, NL, PL, PT, RO, SE, SI, SK, TR), OAPI (BF, BJ, CF, CG, CI, CM, GA, GN, GQ, GW, ML, MR, NE, SN, TD, TG).
- Declarations under Rule 4.17:**
- as to applicant's entitlement to apply for and be granted a patent (Rule 4.17(ii))
  - as to the applicant's entitlement to claim the priority of the earlier application (Rule 4.17(iii))

[Continued on next page]

(54) Title: REFRIGERATOR SHELF ASSEMBLY

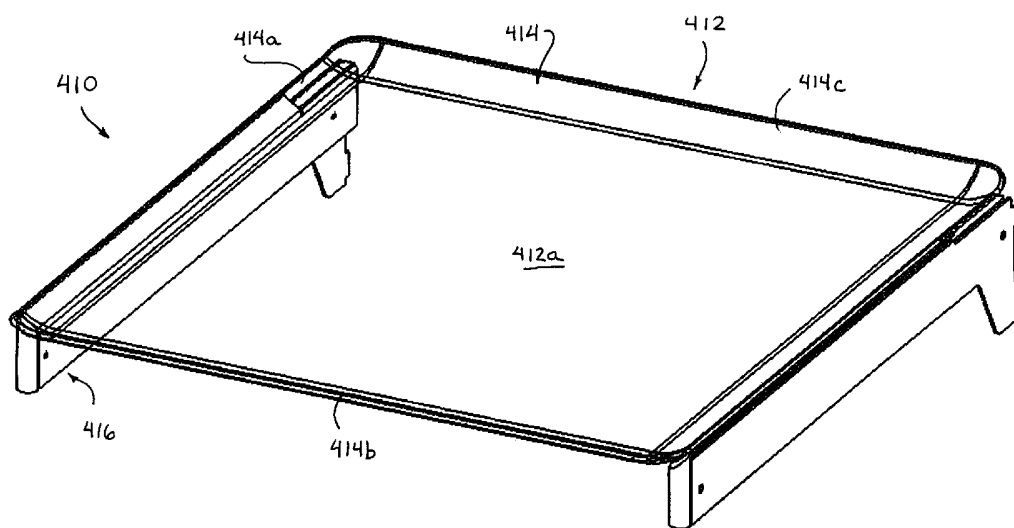

(57) Abstract: A shelf assembly (410) for use in a refrigerator includes a shelf panel (412) and a pair of opposite support rails (416). The shelf panel has upwardly angled perimeter regions (414) and may comprise a strengthened glass material, such as a transparent strengthened glass material, such as tempered glass. Each of the support rails includes a base portion (416a) and an angled portion (416b) that extends at an angle from the base portion. The angled portions of the support rails are bonded along the lower surface (414d) of the upwardly angled side perimeter regions (414a) of the shelf panel.

WO 2006/044641 A2



— of inventorship (Rule 4.17(iv))

**Published:**

— without international search report and to be republished upon receipt of that report

*For two-letter codes and other abbreviations, refer to the "Guidance Notes on Codes and Abbreviations" appearing at the beginning of each regular issue of the PCT Gazette.*

PATENT  
DON06 FP-1242(PCT)  
Express Mail No. EV708292723US

## REFRIGERATOR SHELF ASSEMBLY

### CROSS REFERENCE TO RELATED APPLICATIONS

The present application claims benefit of U.S. provisional applications, Ser. No. 60/619,087, filed Oct. 15, 2004 (Attorney Docket DON06 P-1182); and Ser. No. 60/707,623, filed Aug. 12, 2005 (Attorney Docket DON06 P-1235), which are hereby incorporated herein by reference in their entireties.

### FIELD OF THE INVENTION

The present invention relates to shelving and, more particularly, to glass shelving for refrigerators and the like.

### BACKGROUND OF THE INVENTION

It is known to provide a substantially transparent glass shelf for a refrigerator, where the shelf is supported on a pair of supports extending at least partially along the side edges of the glass shelf. The supports receive the edges of the shelf along side caps or the like to retain the shelf to the supports and to provide a lip along the upper surface of the shelf to form a "spill proof" shelf. Such lips or caps may limit spillage over the edges of the shelves, but may interfere with the upper surface of the shelves and may not be aesthetically pleasing to look at. Examples of such shelves are described in U.S. Pat. Nos. 6,786,562; 6,113,206; 6,120,720; 5,228,764; 6,488,347; 6,679,573; 6,604,800; 4,934,541; and 6,729,704, which are hereby incorporated herein by reference.

### SUMMARY OF THE INVENTION

The present invention provides a shelf assembly, such as a shelf assembly for a refrigerator, where a lower surface of the shelf panel is bonded to a support or rail or slide or roller mechanism extending along each side region of the shelf panel. The shelf panel may have curved or turned or bent edge regions along the support (and optionally along the front and/or rear edges or regions of the shelf panel) to provide a spill proof shelf without end caps or the like along the edges of the shelf panel. The glass shelf panel may include a frit layer or the like along the lower surface of the panel and along the bonded region to provide an enhanced appearance to the shelf assembly.

According to an aspect of the present invention, a shelf assembly for use in a refrigerator includes a shelf panel and at least one support rail or slide or roller mechanism. The shelf panel has a lower surface and comprises a substantially transparent glass material. The support rail is bonded along the lower surface of the shelf panel.

- [0006] The shelf assembly may include a frit layer along the lower surface of the shelf panel, and the support rail may be bonded to the frit layer. Optionally, a frit layer or concealing or substantially non-transparent layer may be provided along the upper surface of the shelf panel and generally at and above the region of the shelf panel where the support rail is located. The support rail may include a generally horizontal support portion that is bonded to the lower surface of the shelf panel, and the generally horizontal support portion may comprise a curved portion.
- [0007] The shelf panel may have at least one perimeter region that is curved, such as upwardly and/or downwardly curved depending on the particular application of the shelf assembly. The shelf panel may comprise a substantially transparent strengthened or toughened or tempered glass material. The opposite side regions of the shelf panel may be curved, and the support rail may bond to the shelf panel along each of the curved side regions of the shelf panel. Optionally, a front region of the shelf panel may also be curved, and/or a rear region of the shelf panel may also be curved.
- [0008] According to another aspect of the present invention, a shelf assembly for use in a refrigerator includes a shelf panel comprising a glass material and a pair of opposite support rails. The shelf panel comprises a generally planar shelf portion, a front perimeter region, a rear perimeter region and opposite side perimeter regions. The front perimeter region, the rear perimeter region and the perimeter side regions are upwardly angled along respective perimeter regions of the generally planar portion of the shelf panel. The upwardly angled side perimeter regions and the upwardly angled front and rear perimeter regions cooperate to provide a substantially continuous upwardly angled perimeter lip around the perimeter regions of the generally planar shelf portion. The side perimeter regions have an upwardly angled lower attachment surface. Each of the support rails have a generally vertical portion and an angled portion that extends at an angle from an upper edge region of the generally vertical portion, which is at a generally vertical orientation when mounted in a refrigerator. The angled portions of the support rails are angled to generally correspond to the angle of the upwardly angled side perimeter regions of the shelf panel. The angled portions of the support rails are bonded along a respective one of the lower attachment surfaces of the side perimeter regions of the shelf panel via a cured adhesive layer.
- [0009] Optionally, the angled portions of the support rails may include generally planar portions and may be angled to generally correspond to the angle of the upwardly angled side perimeter regions of the shelf panel. The generally planar portions of the angled portions of the support rails may be bonded along a respective one of the lower attachment surfaces of

the side perimeter regions of the shelf panel via the cured adhesive layer. Optionally, the shelf panel may be substantially transparent and the cured adhesive layer may be substantially optically matched with the optical index of the shelf panel glass material.

[0010] Therefore, the present invention provides a substantially transparent strengthened glass shelf panel, such as a tempered glass (such as thermally tempered glass or chemically tempered glass) or toughened glass shelf panel or the like, that is bonded along its lower surface and along the side regions of the panel to a pair of side shelf support rails so as to avoid interference or intrusion of the rails onto the upper surface of the shelf panel. The shelf panel may be formed to have curvatures along one or more of the side or front or rear perimeter portions or regions, in order to provide the desired appearance and function, such as a spill proof function or handle function or the like, to the shelf panel. The shelf panel may have a frit layer along its lower surface and in the bonding area along the shelf support rails to conceal the rails so that they are not readily discernible and viewable through the substantially transparent strengthened glass shelf panel.

[0011] These and other objects, advantages, purposes and features of the present invention will become apparent upon review of the following specification in conjunction with the drawings.

#### BRIEF DESCRIPTION OF THE DRAWINGS

[0012] FIG. 1 is a perspective view of a refrigerator shelf assembly in accordance with the present invention, with the side regions turned or curved upwardly along the sides of the shelf panel;

[0013] FIG. 2 is another perspective view of the refrigerator shelf assembly of FIG. 1;

[0014] FIG. 3 is a sectional view of the shelf assembly taken along the line III-III in FIG. 2;

[0015] FIG. 4 is a perspective view of another refrigerator shelf assembly of the present invention, with the side regions turned or curved to form a gutter along the sides of the shelf panel;

[0016] FIG. 5 is a sectional view of the shelf assembly taken along the line V-V in FIG. 4;

[0017] FIG. 6 is a perspective view of another refrigerator shelf assembly of the present invention, with the side regions turned or curved to form a raised bump along the sides of the shelf panel;

[0018] FIG. 7 is a sectional view of the shelf assembly taken along the line VII-VII in FIG. 6;

[0019] FIG. 8 is a perspective view of another refrigerator shelf assembly of the present invention, with a generally flat shelf panel;

[0020] FIG. 9 is a sectional view of the shelf assembly taken along the line IX-IX in FIG. 8;

- [0021] FIG. 10 is a sectional view similar to FIG. 9, showing a shelf panel bonded to a carrier in accordance with the present invention;
- [0022] FIG. 11 is a sectional view similar to FIG. 9, showing another shelf assembly having a support bracket with a spill proof lip in accordance with the present invention;
- [0023] FIG. 12 is a sectional view similar to FIG. 9, showing another shelf assembly having a shelf panel bonded to a slide or roller mechanism;
- [0024] FIG. 13 is a sectional view of the front portion of the shelf panel taken along the line XIII-XIII in FIG. 8;
- [0025] FIG. 14 is a sectional view similar to FIG. 13, showing another shelf panel of the present invention;
- [0026] FIG. 15 is a sectional view similar to FIG. 13, showing another shelf panel of the present invention, with an extruded channel member along the front edge of the shelf panel;
- [0027] FIG. 16 is a perspective view of another shelf assembly in accordance with the present invention;
- [0028] FIG. 17 is a sectional view of another shelf panel of the present invention, with a spill proof form bonded to the upper surface of the shelf panel;
- [0029] FIG. 18 is a perspective view of another shelf assembly of the present invention, with the shelf panel having all four perimeter edge portions turned upward to provide perimetral spill protection;
- [0030] FIG. 19 is an end elevation of one of the support rails along a side edge portion of a shelf panel of the present invention;
- [0031] FIG. 20 is a perspective view of another refrigerator shelf panel in accordance with the present invention;
- [0032] FIG. 21 is a plan view of the shelf panel of FIG. 20, showing planar shelf portion dimensions of an exemplary embodiment of the shelf panel;
- [0033] FIG. 22 is another plan view of the shelf panel of FIG. 20, showing exemplary dimensions of the shelf panel;
- [0034] FIG. 23 is a side elevation of the shelf panel of FIGS. 20-22;
- [0035] FIG. 24 is an enlarged sectional view of a rear portion of the shelf panel of the present invention;
- [0036] FIG. 25 is an enlarged sectional view of a front portion of the shelf panel of the present invention;
- [0037] FIG. 26 is a sectional view of a rear portion of the shelf panel of the present invention;  
and

[0038] FIG. 27 is a sectional view of a side portion of the shelf panel of the present invention.

#### DESCRIPTION OF THE PREFERRED EMBODIMENTS

[0039] Referring now to the drawings and the illustrative embodiments depicted therein, a shelf assembly 10 includes a substantially transparent shelf panel 12 that is supported at least partially along its side regions or edges 14 by respective supports or support brackets or rails 16 (FIGS. 1 and 2). The support brackets 16 are attachable or mountable to a support structure (not shown), such as to a support rack or the like within a refrigerator. The underside or lower surface 18 of shelf panel 12 is bonded to the support brackets 16, such that the support brackets are secured to the lower surface of the shelf panel and thus do not extend over or intrude onto the upper surface of the shelf panel 12. The perimeter side regions or edges 14 and/or the front edge or region 20 and/or the rear edge or region 22 of the shelf panel may be curved or bent to provide a spill proof shelf, as discussed in detail below. Although shown and described as a shelf panel assembly for a refrigerator, the shelf panel assembly of the present invention is intended for use in other types of cabinets or coolers or the like, and the term "refrigerator" is intended to include other food storage containers or cold storage containers or devices or cabinets or freezers or the like, without affecting the scope of the present invention.

[0040] Shelf panel 12 may comprise a glass panel, and preferably a substantially transparent strengthened glass panel, such as a tempered or toughened glass panel, suitable for use in a refrigerator environment. The glass panel may be cut to the desired size and shape for the shelf and may be formed to have the desired curvature along the peripheral edges or perimeter regions of the shelf. For example, the shelf panel may be pressed to bend or turn or curve the perimeter regions to the desired shape. In the illustrated embodiment, of FIGS. 1-3, the panel is press bent or pressed against a form so as to form generally upwardly turned side regions 14 to limit or substantially preclude spillage of liquids over the sides of the shelf. For example, the shelf panel may be pressed upward against a substantially flat form (with curved side or perimeter edges) while the glass shelf panel is heated, whereby the side edge portions of the shelf panel are bent at the perimeter edges of the form. The shelf panel may then be lowered away from the form and cooled or quenched to form the shelf panel. The formed shelf panel may be substantially planar or flat between the curved side edge portions or regions. Other forms may be implemented (as discussed below) to provide the desired function and appearance of the shelf panel, without affecting the scope of the present invention.

[0041] As shown in FIGS. 1 and 3, each support bracket 16 includes a generally vertical portion 16a that may include tabs 24 or the like at a rearward end of the bracket for mounting the support bracket and shelf assembly within the refrigerator, such as in a manner known in the art. As shown in FIG. 3, each support bracket 16 includes a generally horizontal support portion 16b that extends generally horizontally from an upper end of the vertical portion 16a. The support portion 16b may be curved to receive an adhesive bonding material therealong (as discussed below) and/or to generally correspond to the curvature of the side regions 14 of panel 12 (as also discussed below).

[0042] The side regions 14 of shelf panel 12 thus may rest on the support portions 16b of the brackets 16 when the shelf panel is attached to the support brackets 16. As shown in FIG. 3, the lower surface 18 of the shelf panel along the side regions 14 may be bonded to the generally horizontal support portion 16b of support brackets 16, such as via curing of a bonding or adhesive material 26 and utilizing bonding processes of the types described in U.S. Pat. Nos. 6,298,606; 6,128,860; 5,966,874; 5,704,173; and 5,551,197, which are hereby incorporated herein by reference. In the illustrated embodiment, the shelf panel 12 includes a frit layer 28 along the lower surface 18 and along the side regions 14 of the shelf panel to substantially conceal the support brackets or rails along the side regions so that the brackets or rails are not readily viewable through the shelf panel from above the shelf panel. Optionally, however, the shelf panel may not include a frit layer, and the rail or support may be bonded directly to the lower surface of the shelf panel, such as via a UV cured adhesive or the other type of cured adhesive or bonding adhesive or the like, without affecting the scope of the present invention. In such an application, the supports or rails or slide mechanisms may be viewable through the shelf panel.

[0043] The bonding adhesive 26 may be selected from a number of adhesive types or classes including moisture-activated urethanes, such as described in U.S. Pat. No. 3,707,521, which is hereby incorporated herein by reference, moisture-activated silicones, moisture-curable activated urethanes, chemically-activated adhesives, and thermally-activated adhesives, and/or the like. Other adhesives, such as aerobically-cured, anaerobically-cured, and radiation-cured adhesives can also be used, without affecting the scope of the present invention. When cured, the bond-line thickness may be in the range of about 1 micron to 10 mm, preferably about 5 microns to 5 mm, and most preferably about 25 microns to 1 mm. The adhesive may be a moisture-activated adhesive, a chemically activated adhesive, a heat or radiation or ultraviolet or microwave radiation activated adhesive or the like, and the shelf panel and brackets or rails may be exposed to the appropriate conditions or elements or



radiation to cure the adhesive and bond the shelf panel to the brackets or rails, such as described in U.S. Pat. Nos. 6,298,606; 6,128,860; 5,966,874; 5,704,173; and 5,551,197; and 5,331,784, which are hereby incorporated herein by reference.

[0044] Optionally, a temporary fixturing adhesive (not shown) may also be provided, such as a hot-melt thermoplastic, which temporarily locates or fixtures the bracket or rail against the panel or frit layer, while the bonding adhesive 26 cures and forms the permanent primary bond. The temporary fixturing adhesive may secure or hold the brackets to the shelf panel until the bonding process is complete and the bonding adhesive has cured and formed the permanent bond. Optionally, to improve and promote the bonding characteristics of the bonding adhesive, the glass surface (or frit layer if applicable), and/or the rail or bracket portion 16a, may be coated with an adhesion-promoting compound or primer, such as described in U.S. Pat. Nos. 6,298,606; 6,128,860; 5,966,874; 5,704,173; and 5,551,197, which are hereby incorporated herein by reference.

[0045] Optionally, and as shown in the illustrated embodiment, the glass panel may include a frit layer 28 disposed along the side regions of the shelf panel and in the areas or regions at which the brackets are bonded. Optionally, the frit layer may comprise a ceramic frit layer and may function to facilitate adhering or bonding of the edge regions of the shelf panel to the rails. The frit layer is preferably substantially opaque, and thus may improve the overall appearance of the shelf, since the bonding surfaces are not readily discernible or viewable through the shelf panel and the frit layers. Examples of such frit layers are described in U.S. Pat. Nos. 6,298,606; 6,128,860; 5,966,874; 5,704,173; and 5,551,197, which are hereby incorporated herein by reference. The frit layer may comprise a black or substantially opaque layer, or may comprise a white layer or other color as desired, such as to match a color scheme of the refrigerator. The frit layer may be disposed onto the lower surface 18 of the shelf panel in any desired pattern, such as stripes, dots, wave pattern or the like, to provide the desired appearance to the refrigerator shelf, depending on the particular application of the shelf assembly.

[0046] Optionally, the frit layer may be disposed or deposited on and bonded to the lower surface 18 of shelf panel 12 as an opaque frit layer, and most preferably, an opaque ceramic frit layer or coating covering and concealing a region of the surface 18 from a peripheral edge 14a inward. Shelf panel 12, which may be initially in an unstrengthened or untempered condition after cutting and sizing to its desired shape, can be painted, such as by screen coating or other techniques, with a coating of ceramic paint on its lower surface 18. Thereafter, shelf panel 12 may be heated and bent or pressed to the desired contour with a

bending furnace or other bending apparatus, followed by strengthening, such as tempering, to strengthen the glass. Such heating, bending and tempering operations cause the ceramic paint to become fused to the lower surface of the shelf panel. Thus, although starting as a layer of paint containing ceramic particles and pigment, the coating ends up as a thin frit layer of ceramic material, which is fused to the lower surface of the glass shelf panel. Since the ceramic frit coating includes a pigment of a desired color, the layer results in a permanent, second or lower surface coloration of the glass shelf panel. However, and as discussed above, the rails or supports may be bonded to the lower surface of the shelf panel without any frit layer on the shelf surface, without affecting the scope of the present invention.

[0047] The refrigerator shelf of the present invention thus provides a substantially transparent or clear shelf panel (such as a strengthened or tempered glass panel) that is mounted to or bonded to support brackets or rails with no caps or lips extending over the perimeter edges and onto the upper surface of the shelf panel. The shelf panel may be formed to have a desired raised shape or lip along one or more of the perimeter edges or regions to limit spillage of liquids over the formed or curved perimeter region or regions. The present invention thus provides a strengthened or tempered glass shelf that is bonded to the support brackets and that has upwardly turned or curved perimeter edge regions. Optionally, and desirably, the mounting or bonding portions of the supports or brackets may have bumps or raised portions or dimples or protrusions spaced along the generally horizontal portion of the supports to set the desired or appropriate bond gap or bond layer thickness between the shelf panel surface and the mating surface of the supports or rails or brackets.

[0048] Preferably, the shelf panel of the present invention comprises a substantially clear or transparent panel and the bracket comprises a polished or finished metal bracket (such as a painted or coated bracket or a brushed aluminum bracket or a brushed or polished stainless steel bracket or the like). Such a substantially clear shelf panel is often desired for various refrigerator applications or other food storage containers or cabinets or freezers or the like. The brackets and shelf panel of the present invention may be attached or secured or bonded together via a curable adhesive bonding material, and the curable adhesive bonding material may be selected to be substantially transparent or clear and, preferably, may be index matched or substantially index matched to the glass material (which may have an optical index of approximately 1.45 to approximately 1.55, more preferably about 1.48 to about 1.53, and more preferably about 1.5 to about 1.52) and may have few to no bubbles or other noticeable imperfections. Thus, a person viewing through the shelf panel from above may principally see or view the bracket and the mounting portion of the bracket under the shelf

and not the adhesive or any other materials or components of the shelf assembly. Optionally, the mounting surfaces or portions of the brackets may be textured or finished or otherwise formed/processed so as to be aesthetically pleasing or cosmetically attractive for viewing through the shelf panel and the adhesive bonding layer. Optionally, spacers or beads or the like may be positioned along the bond line to space the shelf panel the appropriate or desired amount above the mounting portion of the brackets, so as to provide a desired bond layer thickness between the mounting portions and the shelf panel. Optionally, and desirably, such spacers or beads may also be optically index matched with the adhesive material and/or the glass panel material.

[0049] Optionally, the perimeter regions of the shelf panel may be formed to have other shapes, without affecting the scope of the present invention. For example, a refrigerator shelf assembly 10' (FIGS. 4 and 5) may include a shelf panel 12' that is pressed or formed or curved to have a channel or trough 30 along the perimeter side edges or regions 14'. As shown in FIG. 5, the shelf support or rail 16' may include a curved generally horizontal portion 16b' that is curved to form a channel that generally corresponds to the shape of the side regions 14' of the shelf panel 12'. The shelf panel may be bonded to the shelf brackets via a bonding material 26', and the lower surface 18' of shelf panel 12' may include a frit layer 28' along the side regions 14', in a similar manner as described above.

[0050] Similarly, and with reference to FIGS. 6 and 7, a refrigerator shelf assembly 10" may include a shelf panel 12" that has a raised bump 32 or reversed channel or trough formed along the perimeter side edges or regions 14". As shown in FIG. 7, the shelf support or bracket or rail 16" may include a curved generally horizontal portion 16b" that is curved to form a channel for receiving the bonding material 26" therealong to bond the panel to the support bracket. The lower surface 18" of shelf panel 12" may include a frit layer 28" along the side regions 14" in a similar manner as described above.

[0051] Optionally, and with reference to FIGS. 8 and 9, the refrigerator shelf assembly 110 may include a substantially flat shelf panel 112 that is supported on support brackets or rails 116. The perimeter side regions 114 may be bonded to a generally horizontal and partially curved support portion 116b of brackets 116 via a bonding material 126 in a similar manner as described above. The shelf panel 112 may include a frit layer 128 along the lower surface 118 and along the side regions 114, such as described above.

[0052] Optionally, and as shown in FIG. 10, the support bracket 116' may include a carrier member 134 that is bonded to the shelf panel 112' and that engages or attaches to or receives a portion of the generally horizontal support portions 116b' to secure the shelf panel 112' to

the support brackets 116'. In the illustrated embodiment, the carrier member 134 is a generally C-shaped member extending along the lower surface and side regions of the shelf panel (when bonded thereto) and receives an edge or end 116c' of the horizontal portion 116b' of the support bracket 116'. The carrier member 134 may be bonded to the lower surface 118' of panel 112', and preferably to a frit layer 128' at the bonding area 126' along the edge portion 114' of the panel 112'. Such a carrier member may be suitable for use with any of the other shelf panels of the present invention, such as the upwardly curved or channel shaped shelf panels, without affecting the scope of the present invention.

[0053] Optionally, and with reference to FIG. 11, the support bracket or rail 116" of a shelf assembly 110" may include a generally vertical portion 116a" that extends upward above the generally horizontal portion 116b" and that extends or protrudes above the upper surface 136 of the shelf panel 112", in order to provide a lip 138 at least partially along the side edge of the shelf panel to provide a spill proof function to the refrigerator shelf assembly 110". The shelf panel 112" may be substantially flat or planar (as shown in FIG. 11) or may include generally flat side regions or edge portions 114" or curved or bent side regions or edge portions, without affecting the scope of the present invention. The lower surface 118" of the shelf panel 112" may include a frit layer 128" thereon and may be bonded (at bonding region 126") to the generally horizontal portion 116b" of the shelf support brackets 116", in a similar manner as described above.

[0054] Optionally, and as shown in FIG. 12, a shelf panel 112'" of a shelf assembly 110'" may be slidably or movably mounted to the support rails or brackets 116'" and may be movable along the support rails or brackets, such as via a slide mechanism or roller mechanism 144 or the like. For example, the support bracket or rail 116'" may include a roller or rollers 144a (such as two or more rollers spaced along the support bracket) that extend from the rail 116'" and rollingly engage or rotatably support a carrier or rail 144b of a shelf panel 112'". The carrier 144b may be an elongated rail that defines a channel or track 144c for rotatably receiving the rollers 144a, such that an upper surface 144d of the channel or track 144c rests on the rollers 144a when the shelf panel is mounted to the support or rail or bracket 116'". The carrier 144b may be bonded to the lower surface 118'" of shelf panel 112'" (and optionally may be bonded to a frit layer along the lower surface of the shelf panel), such as via a bonding adhesive 126'". The shelf panel 112'" thus may be slidably or movably mounted to the support rail 116'" to facilitate movement of the shelf panel along the support rails or channels. Although shown as a roller and track mechanism, other moving or rolling or sliding means may be implemented to provide relative movement between the shelf panel

and the generally fixed support that is mounted in the refrigerator, without affecting the scope of the present invention.

[0055] Optionally, the front and/or rear perimeter regions or edges of the shelf panel may be curved or formed to provide a spill proof function and/or to provide a handle or the like for a user to grasp to move the shelf, such as to lift the shelf to detach the support brackets or rails from the support within the refrigerator, such as to adjust a height or position of the shelf within the refrigerator. For example, and as shown in FIG. 13, the forward edge 120 of the shelf panel may be curved upwardly to provide a spill proof edge along the front of the shelf panel. Optionally, and with reference to FIG. 14, the forward edge 120' may be curved to form a bump 132 along the front edge of the shelf panel. Alternately, the forward edge 120" (FIG. 15) may be generally flat and may be received within and along an extruded member or lip 140 that may provide a handle function and/or a spill proof function along the front edge of the shelf panel. Other shapes or curvatures or forms may be implemented may be implemented without affecting the scope of the present invention.

[0056] As shown in FIG. 16, a shelf panel 212 may have a bump or raised curvature 232 along the front edge portion 220 and along the side portions 214 (and optionally along the rear edge portion (not shown in FIG. 16) as well) to form a shelf panel that provides a spill proof function substantially or entirely around the perimeter of the shelf panel. The curved perimeter regions may be formed by pressing the strengthened or tempered or toughened glass panel or sheet against a desired form to bend the glass to the desired shape along one or more of its perimeter regions or edges. The panel may be cut or otherwise formed to have a handle portion 242 at a generally central region along the front edge portion 220. Optionally, it is envisioned that the front region may include a frit layer along at least a portion of the front of the shelf panel to enhance the appearance of the shelf and/or to make the handle portion readily viewable and discernible, depending on the application of the shelf assembly.

[0057] Optionally, and with reference to FIG. 17, a shelf panel 312 may include an upper frame portion or form or guard 346 bonded to the upper surface 336 of shelf panel 312 and along one or more edge regions 314, 320, 322 of the shelf panel. The upper form 346 may be bonded to the upper surface 336, such as via a bonding adhesive 326, such as described above. The upper form or forms are thus bonded to the upper and often Class A finish surface (i.e. a surface readily viewable by a user of the refrigerator and thus required to be aesthetically and functionally acceptable) of the shelf panel. Optionally, the upper form or forms may be bonded to a frit layer at the upper surface of the shelf panel, without affecting the scope of the present invention. The upper form or forms may comprise a polymeric or

plastic material or may comprise a metallic material or the like, without affecting the scope of the present invention. The upper form 346 provides a spill containment function to the otherwise generally flat surface of the shelf panel along the edge region or regions.

[0058] The upper form 346 may be bonded to the upper surface along the front and/or rear perimeter regions of the shelf panel, particularly for applications where the side regions of the shelf panel are turned upwardly or otherwise formed to provide a spill containment function. Alternately, or additionally, the form may be bonded to the upper surface along the side perimeter regions of the shelf panel, particularly for applications where the front and rear perimeter regions are upwardly turned or otherwise formed to provide a spill containment function. Optionally, an upper frame portion may comprise four sections unitarily formed or joined together and bonded to the upper surface of the shelf panel and along all four perimeter regions of the shelf panel to provide a spill containment function around the perimeter of the shelf panel.

[0059] Although shown in FIG. 17 as a curved or half-moon shaped form, the upper form or forms or frame may be any other shape or form, without affecting the scope of the present invention. It is further envisioned that the upper form or forms or frame may be shaped or molded or otherwise formed to provide other functions. For example, the form or forms may be shaped or molded or otherwise formed to provide a storage or holding function for holding or storing refrigerated items, such as bottles or cans or eggs or the like. For example, the form or forms may include generally cylindrical depressions or recesses for receiving bottles or cans, or may include depressions or recesses for holding or receiving other items, such as eggs or the like. The forms or frame thus may be larger than the form shown in FIG. 17, and may encroach further onto and over the upper surface of the shelf panel to provide for sufficient sized shapes or depressions or recesses or the like for receiving and/or holding and/or retaining the appropriate items or goods thereon. The upper frame or form of the present invention thus may provide a spill containment function and/or a food/drink/etc. storage or holding or retaining function at or near or along the perimeter regions of the upper surface of the shelf panel, and optionally along other regions of the upper surface of the shelf panel as desired.

[0060] Optionally, and with reference to FIG. 18, a shelf assembly 410 includes a shelf panel 412 supported on support rails or slides or roller assemblies 416. The shelf panel 412 comprises a glass panel with a generally planar central or storage portion 412a and an upwardly turned or curved perimeter portion or spill prevention portion 414. The perimeter portion 414 includes opposite upwardly turned or curved side edge portions 414a, an

upwardly turned or curved front edge portion 414b and an upwardly turned or curved rear edge portion 414c, so that the entire perimeter edge portion of the shelf panel is curved or bent upwardly to limit or substantially preclude spillage. The shelf panel thus may provide a substantially planar support portion and a four-sided integrated spill protection portion that circumscribes the circumference or entire perimeter of the substantially planar support portion of the shelf panel.

[0061] The shelf panel may comprise a tempered glass panel and may be substantially transparent or translucent so that a person may readily view items through the shelf panel or panels of a refrigerator. Optionally, the glass may comprise a thermally tempered glass or a chemically tempered glass, whereby the glass panel may be made with a reduced thickness of about one millimeter thick or thereabouts, while providing enhanced strength over other types of glass materials. The panel may be press bent or pressed against a form so as to form generally upwardly turned perimeter regions or edge portions to limit or substantially preclude spillage of liquids over the front, rear and/or sides of the shelf panel. For example, the shelf panel may be pressed upward against a substantially flat form (with curved perimeter edges) while the glass shelf panel is heated or at an elevated temperature, whereby the perimeter edge portions of the shelf panel are bent at the perimeter edges of the form. The shelf panel may then be lowered away from the form and cooled or quenched (such as air quenched) to form the shelf panel. The formed shelf panel may be substantially planar or flat at the central, support or storage region.

[0062] Optionally, the shelf panel may be formed via other forming techniques, such as glass molding or the like, to achieve the desired form. Optionally, anchor points or bumps or the like may be molded into the lower surface of the side edge portions of the molded shelf panel to provide anchor points for setting the bracket location. Optionally, a portion of the bracket may be molded with the shelf panel so as to provide an integrally or unitarily molded shelf panel and bracket portion. Desirably, the shelf panel comprises substantially clear or transparent glass, but may comprise a tinted glass or colored glass or a plastic material or the like, and may have a pattern or frit layer or the like screened or otherwise applied to the glass or plastic material.

[0063] As shown in FIGS. 18 and 20-23, the front and side perimeter edge portions 414b, 414a of shelf panel 412 may protrude upwardly, such as, for example, about five to ten millimeters or thereabouts, while the rear perimeter edge portion 414c may protrude upwardly a greater amount, such as, for example, about ten to fifteen millimeters or thereabouts, in order to provide a greater lip or raised edge portion along the rear of the shelf

panel to substantially preclude items from falling off the rear of the shelf panel. For example, and as shown in FIGS. 23, 24 and 26, the rear edge portion may be turned upwardly to provide a spill prevention lip that extends upward about 14.5 mm from a lower surface of the shelf panel, while FIGS. 23, 25 and 27 illustrate that the front edge portion 414b and/or the side edge portions 414a may be turned upwardly to provide a spill prevention lip that extends upward about 10 mm from the lower surface of the shelf panel. The shelf panel 412 and the edge portions 414a, 414b, 414c may be formed and sized to provide the desired generally planar shelf support area and desired spill limiting perimeter lip for the refrigerator shelf. For example, and as can be seen with reference to FIGS. 21 and 22, the shelf panel may have cross dimensions X, Y (FIG. 22) of about 435 mm by about 444 mm, with a generally planar support portion having cross dimensions X', Y' (FIG. 21) of about 402 mm by about 397 mm. Such a configuration thus may provide a substantially large generally planar support portion with a reduced amount of the overall shelf length and width dimensions being dedicated to the formation of the upwardly turned spill prevention portions.

[0064] The shelf panel 412 is supported by a pair of opposite rails or support brackets 416. In the illustrated embodiment, and as can be seen in FIGS. 19 and 27, the side perimeter edge portions 414a are curved upwardly and provide a substantially planar attachment region 414d for attaching a substantially planar bracket attachment portion 416b of the support brackets 416 thereto, as discussed below. For example, and as shown in FIG. 27, the side edge portion 414a may have an upwardly turned angle of approximately 30 degrees (but could be formed at other angles, without affecting the scope of the present invention). The front edge portion and/or rear edge portion may have a similar upwardly turned angle, or may have a greater or lesser upward angle. For example, the front and side edge portions may have similar upward angles (such as about 30 degrees), while the rear edge portion is curved or bent or formed at a greater angle, such as, for example, about 60 degrees, without affecting the scope of the present invention. Such a difference in angles between the side edge portions 414a and the rear edge portion 414c can be seen with reference to FIGS. 26 and 27. The upward angle of the side edge portions may be selected to correspond to the upward angle of the angled attachment portion 416b of the support brackets, so that the support brackets substantially uniformly engage the side edge portions of the shelf panel, as can be seen in FIG. 19.

[0065] As shown in FIG. 26, the rear perimeter edge portion 414c may be curved or angled upwardly and may be curved upwardly from a location, for example, about 30 mm (or thereabouts) inward from the rear edge (which defines the rear perimeter edge region of the planar portion 412a). The rear perimeter edge portion 414c may curve upwardly at a desired



angle and may provide a generally planar or flat region of about 6 mm or thereabouts at an upper portion of the rear edge portion 414c. Likewise, and as shown in FIG. 27, the side perimeter regions or portions 414a may curve upwardly from a side perimeter edge of the planar portion 412a, such as at a location, for example, about 25 mm (or thereabouts) inward from the outer edge of the shelf panel. The side perimeter regions 414a may curve upwardly and may provide the generally planar attachment portion or surface 414d, which may have a generally planar surface of, for example, about 12 mm wide or thereabouts along the length or substantially along the length of the side perimeter portions 414a.

[0066] Support brackets 416 may be similar to the brackets described above, and may include a generally vertical arm portion 416a and an angled attachment portion 416b for attaching or adhering to the attachment portion or surface 414d of the upwardly turned perimeter side edge portions 414a of shelf panel 412. In the illustrated embodiment of FIG. 18, brackets 416 are roller assemblies that include roller bearings such that the shelf panel may be substantially smoothly moved between a retracted position and an extended position to ease loading and unloading of items on the shelf. Although shown in FIG. 18 as a roller support assembly, the bracket may comprise a static bracket or a friction slider type bracket or a roller/slider type bracket, without affecting the scope of the present invention. For example, and as shown in FIG. 19, the bracket 416' may comprise a static bracket with a generally vertical arm portion 416a' and an angled attachment portion 416d', with the angled attachment portion 416d' angling upward and laterally outward (and angled at an angled or bent region or knee region 416e') to substantially coincide with the angle of the perimeter edge portions. Optionally, the bracket attachment portion may angle downwardly and inwardly, with the vertical arm portion at the outward portion of the bracket, or the bracket attachment portion may be generally horizontal and may extend laterally inward to attach to the lower surface of the generally planar support portion of the shelf panel, without affecting the scope of the present invention. Optionally, and desirably, the mounting or bonding portions of the support rails or brackets may have bumps or raised portions or dimples or protrusions (such as protrusions 416f' in FIG. 19) spaced along the angled attachment portion to set the desired or appropriate bond gap or bond layer thickness between the shelf panel surface and the mating surface of the supports or rails or brackets.

[0067] The brackets may comprise any suitable material, such as a metallic material, such as a powder coated metallic material (such as a white powder coat or a stainless steel looking powder coat or other coatings) or other metallic materials, such as stainless steel or the like, or may comprise a plastic or polymeric material, without affecting the scope of the present

invention. Optionally, and particularly for slide out or roller bracket applications, the front portion of the shelf panel may include a handle portion formed or established thereon. For example, a handle portion or gripping or grasping element may be bonded to the front portion (such as to the lower surface of the planar support portion and/or of the upwardly turned front portion), to provide a means for a person to readily grasp the shelf panel to pull the shelf panel outward, such as for loading or unloading items at the shelf panel.

[0068] As can be seen in FIG. 19, attachment portion 416b' of bracket 416' is angled relative to arm portion 416a' to generally correspond with the planar attachment region 414d of side perimeter edge portions 414a of shelf panel 412. A bead of suitable adhesive 417 (such as discussed below) may be applied along the attachment portion of the bracket and/or along the attachment region of the side perimeter edge portion, and the bracket may then be pressed against the attachment region of the shelf panel to adhere or bond the bracket to the shelf panel. As also shown in FIG. 19, the attachment portion 416b' may include a channel or groove 416c' therealong that receives and retains excess adhesive when the bracket is pressed against the attachment region of the shelf and with a bead of adhesive therebetween.

[0069] The attachment portion 416b thus may be readily adhered to or bonded to the attachment region 414d, such as via a bead of adhesive or the like. Desirably, the adhesive may comprise a transparent adhesive, such as a transparent or substantially transparent epoxy or acrylate or the like. Optionally, the adhesive may comprise a UV curable adhesive, such as a UV curable acrylate or epoxy or a UV curable optically matching adhesive, such as the optical adhesives of the types commercially available from Norland Products of Cranbury, NJ, or other suitable transparent or substantially transparent adhesive. Such UV curable adhesives provide rapid curing or bonding of the glass shelf panel to the support bracket after the bracket is pressed against the attachment portion of the panel with the adhesive therebetween.

[0070] Preferably, the adhesive is selected to be at least partially to substantially space filling so that any tolerances or gaps between the attachment portion 416' of bracket 416' and the lower attachment region 414d of shelf panel 412 are filled in or taken up by the adhesive. Preferably, the adhesive is a clear or substantially transparent adhesive to limit viewability of the adhesive. Optionally, beads, such as index matching beads, such as glass beads or fibers or polymeric beads or fibers or the like, may be provided so that the adhesive has an enhanced space filling function between the bracket and the shelf panel.

[0071] Optionally, the attachment regions of the shelf panel may have a non-transparent coating or frit layer or paint or ink or the like disposed thereon, so as to substantially conceal

the support bracket and limit viewing of the support bracket and adhesive through the shelf panel. The frit layer may be disposed or established on the underside of the shelf panel. However, because the lower surface of the shelf panel typically may pass over and contact rollers while the glass is still hot (during manufacturing of the shelf panel), it may be desirable to dispose or establish a frit or paint or ink layer or coating on the upper surface of the shelf panel and along the side attachment regions, while the support bracket is bonded or adhered to the lower uncoated glass surface of the shelf panel. Optionally, the frit or paint or ink layer or coating may be disposed or screened onto either the lower surface or upper surface of the shelf panel after forming the shelf panel. In applications where a non-transparent frit layer or other pattern or the like may be disposed at the attachment portion of the shelf panel, the adhesive may comprise a substantially non-transparent adhesive.

[0072] Therefore, the present invention provides a substantially transparent glass shelf panel that is bonded along the side regions of its lower surface to a pair of side shelf support brackets so as to avoid interference or intrusion onto the upper surface of the shelf panel. The shelf panel may be formed to have curvatures along one or more side or front or rear perimeter portions or regions, in order to provide the desired appearance and function, such as a spill proof function or handle function or the like, to the shelf panel. The shelf panel may include a frit layer along its lower surface and in the bonding area along the shelf support brackets to conceal the brackets so that they are not readily discernible and viewable through the substantially transparent glass shelf panel. The shelf panel may include an upper frame or form bonded to the upper surface of the shelf panel to provide a spill containment function and/or a storage or holding function at the upper surface of the shelf panel.

[0073] Changes and modifications to the specifically described embodiments can be carried out without departing from the principles of the present invention, which is intended to be limited only by the scope of the appended claims as interpreted according to the principles of patent law.

[0074] The embodiments of the invention in which an exclusive property or privilege is claimed are defined as follows:

1. A shelf assembly (410) for use in a refrigerator, said shelf assembly comprising:  
a shelf panel (412) comprising a glass material;  
said shelf panel comprising a generally planar shelf portion (412a), a front perimeter region (414b), a rear perimeter region (414c) and opposite side perimeter regions (414a);  
said front perimeter region, said rear perimeter region and said perimeter side regions being upwardly angled along respective perimeter regions of said generally planar portion;  
said upwardly angled side perimeter regions and said upwardly angled front and rear perimeter regions cooperating to provide a substantially continuous upwardly angled perimeter lip around said perimeter regions of said generally planar shelf portion;  
said side perimeter regions having an upwardly angled lower attachment surface (414d); and  
a pair of opposite support rails (416'), each of said support rails having a generally vertical portion (416a') and an angled portion (416b') that extends at an angle from an upper edge region of said generally vertical portion, said angled portions of said support rails being angled to generally correspond to the angle of said upwardly angled side perimeter regions of said shelf panel, said angled portions of said support rails being bonded via a cured adhesive layer (417) along a respective one of said lower attachment surfaces of said side perimeter regions of said shelf panel.
2. The shelf assembly of claim 1, wherein said shelf panel comprises strengthened glass.
3. The shelf assembly of claim 1, wherein said angled portions of said support rails include generally planar portions that are bonded to said lower attachment surfaces of said side perimeter regions of said shelf panel.
4. The shelf assembly of claim 3, wherein said angled portions of said support rails comprise curved portions.
5. The shelf assembly of claim 1, wherein each of said support rails comprises a slide mechanism.

6. The shelf assembly of claim 5, wherein said slide mechanism comprises a fixed rail that is mountable in the refrigerator and a movable rail that includes said angled portion that is bonded to said lower attachment surface of said side perimeter regions of said shelf panel, said movable rails being movable along said fixed rails of said support rails to move said shelf panel relative to said fixed rail.
7. The shelf assembly of claim 6, wherein one of said fixed rail and said movable rail includes at least one roller and the other of said fixed rail and said movable rail defines a track therealong, said roller rolling along said track as said shelf panel moves relative to said fixed rail.
8. The shelf assembly of claim 1 including a frame portion bonded to an upper surface of said shelf panel.
9. The shelf assembly of claim 8, wherein said frame portion is bonded along at least one of said perimeter regions of said shelf panel.
10. The shelf assembly of claim 8, wherein said frame portion provides a storage function for holding at least one item.
11. The shelf assembly of claim 1 including a frit layer along said upwardly angled side perimeter regions of said shelf panel.
12. A shelf assembly (410) for use in a refrigerator, said shelf assembly comprising:
  - a shelf panel (412) comprising a tempered glass material;
  - said shelf panel comprising a generally planar shelf portion (412a), a front perimeter region (414b), a rear perimeter region (414c) and opposite side perimeter regions (414a);
  - said front perimeter region, said rear perimeter region and said perimeter side regions being upwardly angled along respective perimeter regions of said generally planar portion;
  - said upwardly angled side perimeter regions and said upwardly angled front and rear perimeter regions cooperating to provide a substantially continuous upwardly angled perimeter lip around said perimeter regions of said generally planar shelf portion;
  - said side perimeter regions having an upwardly angled lower attachment surface (414d);

a pair of opposite support rails (416'), each of said support rails having a generally vertical portion (416a') and an angled portion (416b') that extends at an angle from an upper edge region of said generally vertical portion; and

said angled portions of said support rails including generally planar portions and being angled to generally correspond to the angle of said upwardly angled side perimeter regions of said shelf panel, said generally planar portions of said angled portions of said support rails being bonded along a respective one of said lower attachment surfaces of said side perimeter regions of said shelf panel via a cured adhesive layer (417).

13. The shelf assembly of claim 12, wherein said generally planar portions include a plurality of protrusions (416f') to set a bond layer thickness of said cured adhesive layer between said support rails and said lower attachment surfaces of said shelf panel.

14. The shelf assembly of claim 12, wherein said glass shelf panel comprises a substantially transparent glass material, said cured adhesive layer comprising a substantially transparent material.

15. The shelf assembly of claim 14, wherein said cured adhesive layer comprises an optical index that generally corresponds with an optical index of said substantially transparent glass material.

16. A shelf assembly (410) for use in a refrigerator, said shelf assembly comprising:  
a shelf panel (412) comprising a substantially transparent glass material having a first optical index;

said shelf panel comprising a generally planar shelf portion (412a), a front perimeter region (414b), a rear perimeter region (414c) and opposite side perimeter regions (414a);

said front perimeter region, said rear perimeter region and said perimeter side regions being upwardly angled along respective perimeter regions of said generally planar portion;

said upwardly angled side perimeter regions and said upwardly angled front and rear perimeter regions cooperating to provide a substantially continuous upwardly angled perimeter lip around said perimeter regions of said generally planar shelf portion;

said side perimeter regions having an upwardly angled lower attachment surface (414d);

a pair of opposite support rails (416'), each of said support rails having a generally vertical portion (416a') and an angled portion (416b') that extends at an angle from an upper edge region of said generally vertical portion, said angled portions of said support rails being angled to generally correspond to the angle of said upwardly angled side perimeter regions of said shelf panel; and

said angled portions of said support rails being bonded along a respective one of said lower attachment surfaces of said side perimeter regions of said shelf panel via a cured adhesive layer (417), said cured adhesive layer having a second optical index, said first optical index substantially matching said second optical index.

17. The shelf assembly of claim 16, wherein said angled portions of said support rails include generally planar portions that are bonded to said lower attachment surfaces of said side perimeter regions of said shelf panel.

18. The shelf assembly of claim 17, wherein said generally planar portions include a plurality of protrusions (416f') to set a bond layer thickness of said cured adhesive layer between said support rails and said lower attachment surfaces of said shelf panel.

19. The shelf assembly of claim 17 including spacing elements between said generally planar portions of said support rails and said lower attachment surfaces of said shelf panel, said spacing elements having a third optical index that substantially matches said first and second optical indexes.

20. The shelf assembly of claim 17, wherein said support rails include a plurality of protrusions extending from said generally planar portions to set a thickness of said adhesive layer between said generally planar portions of said support rails and said lower attachment surfaces of said shelf panel.

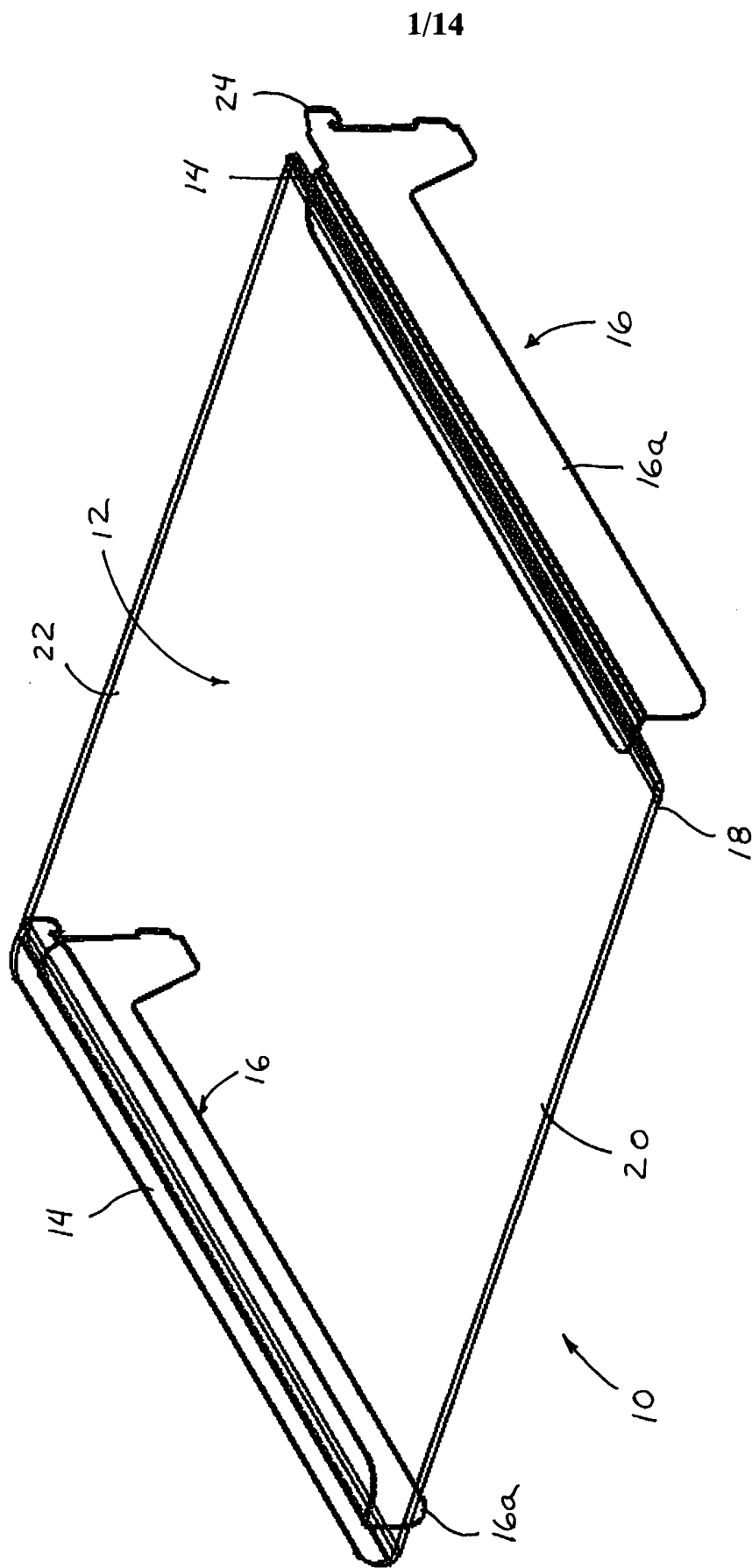

FIG. 1



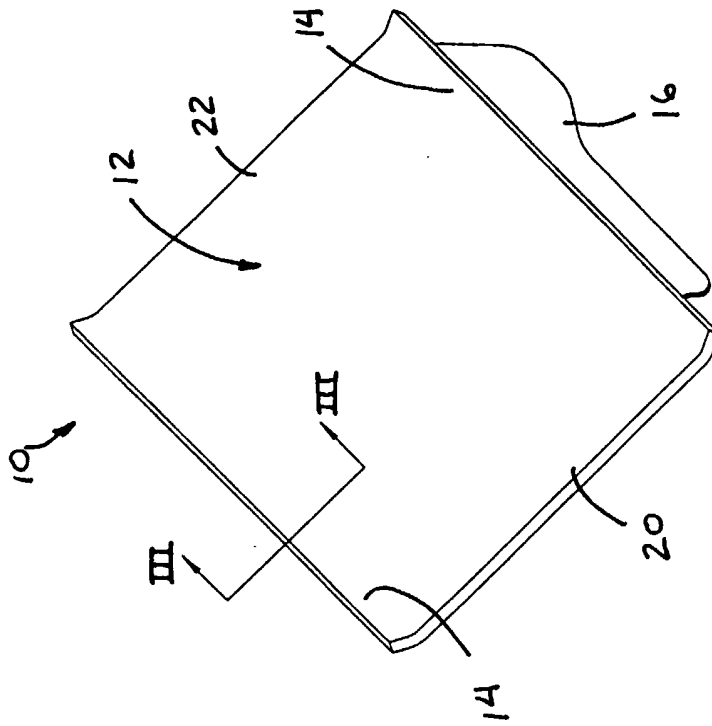

FIG. 2

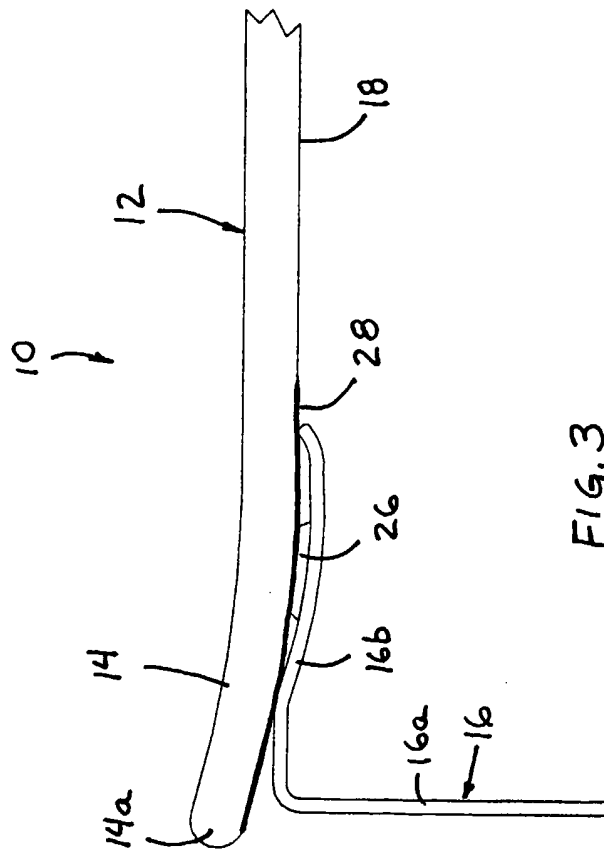

FIG. 3

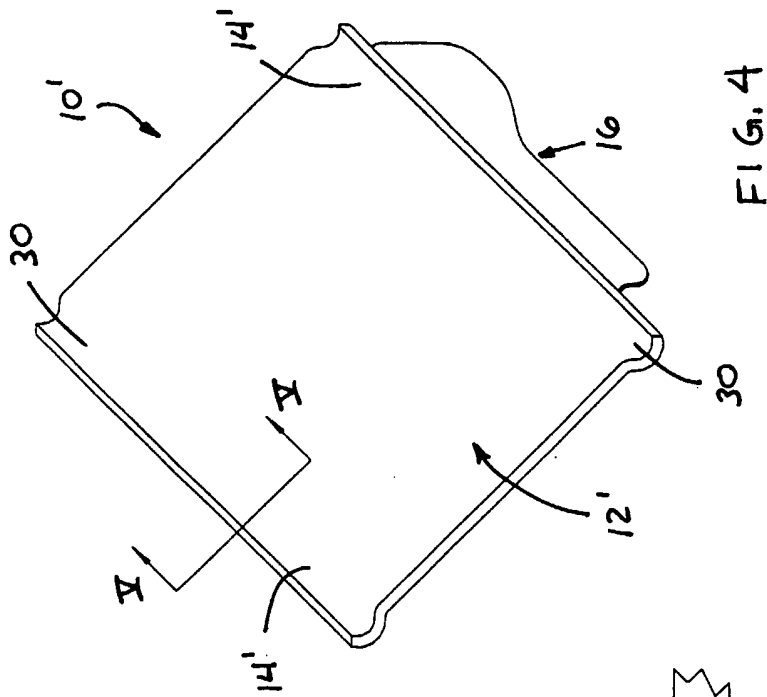

FIG. 4

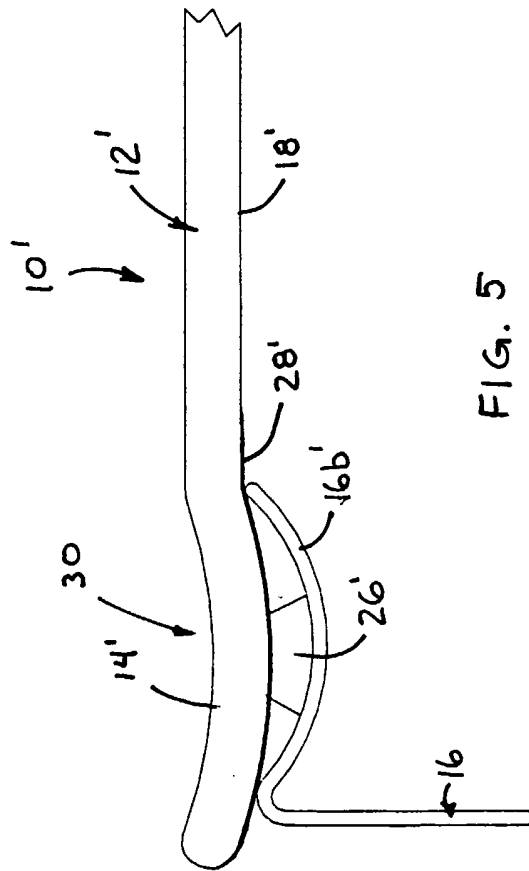
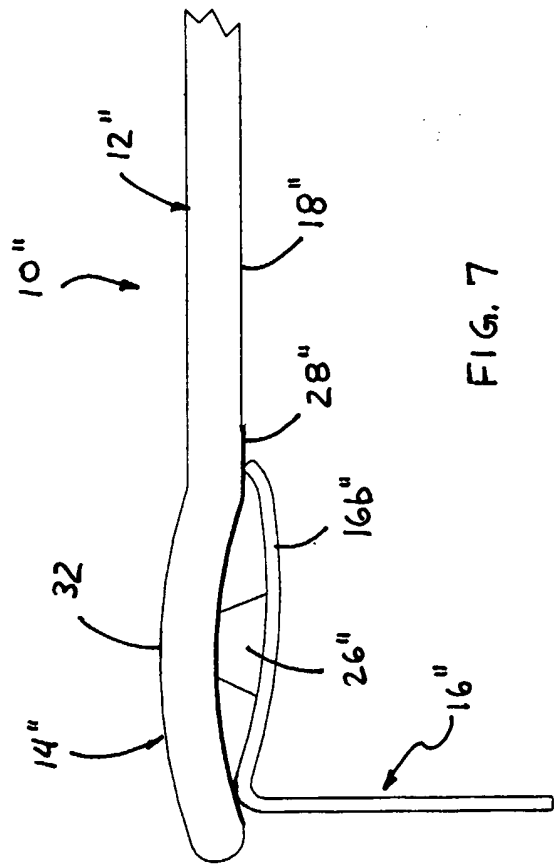
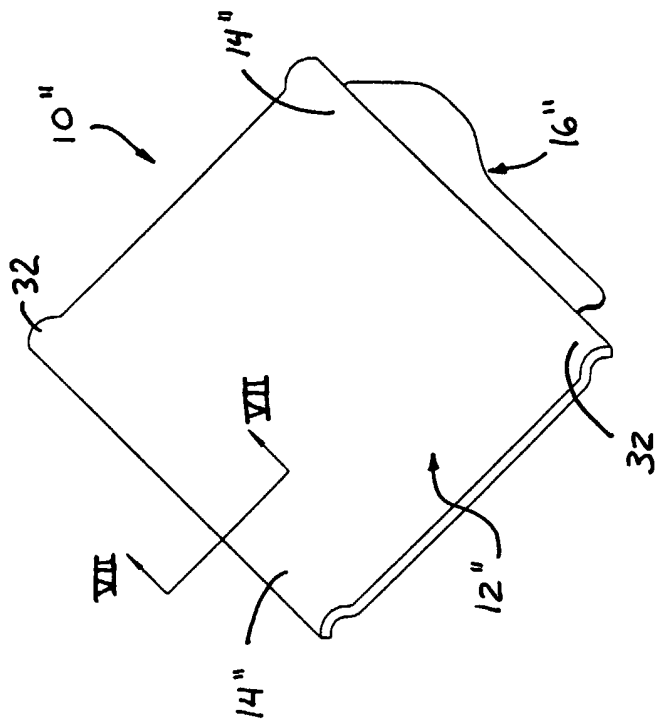

FIG. 5



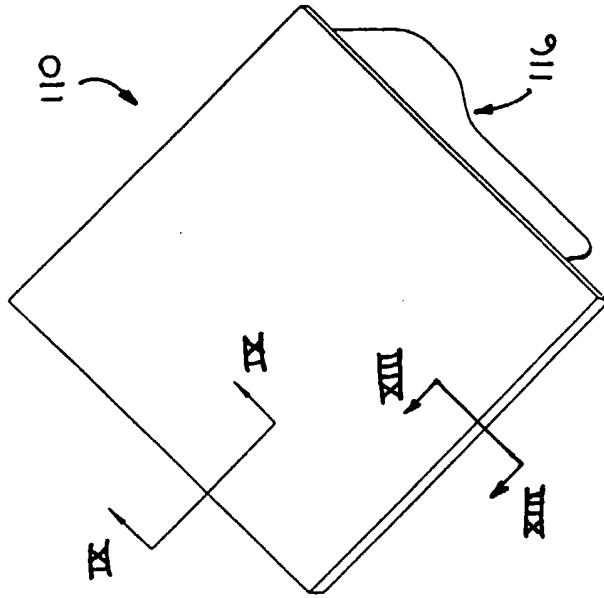

FIG. 8

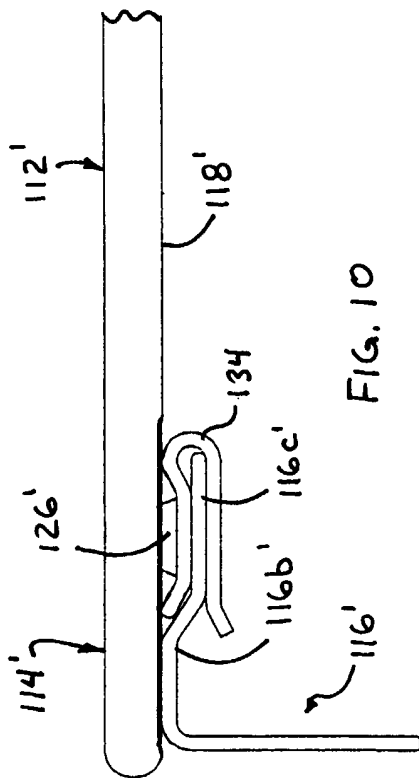

FIG. 10

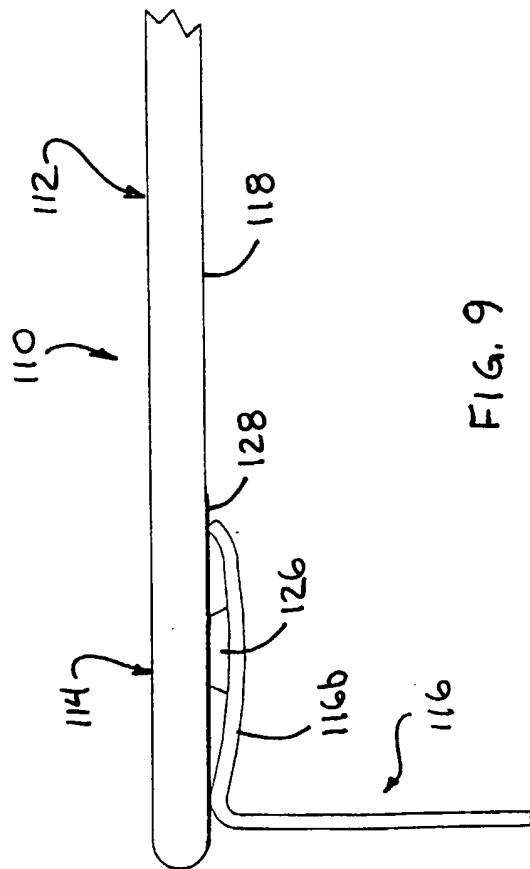

FIG. 9

FIG. 11

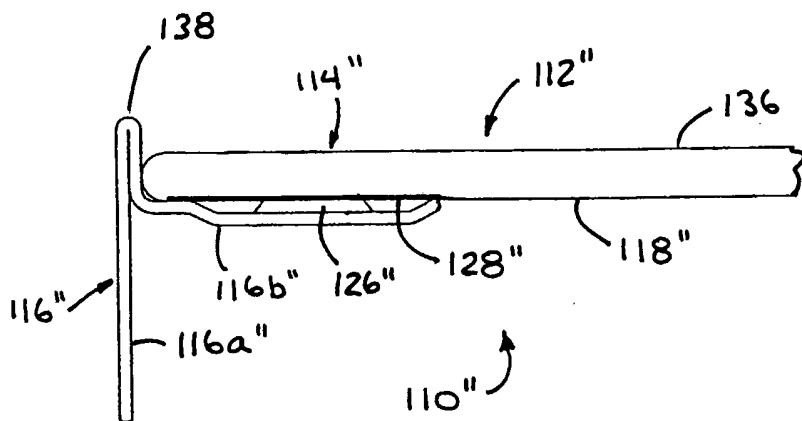

FIG. 13

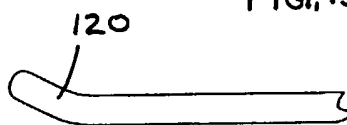

FIG. 14

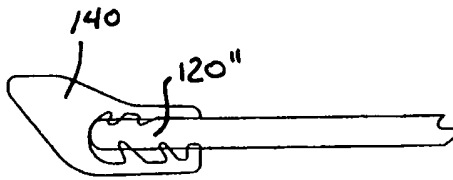
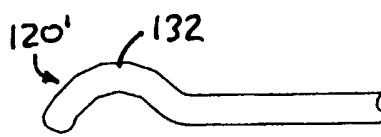
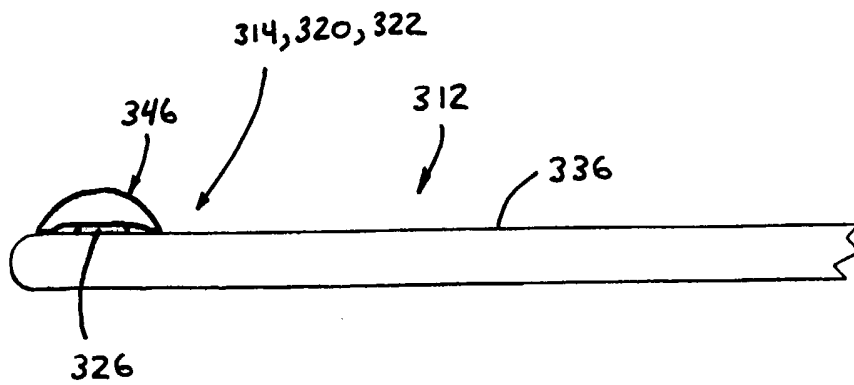
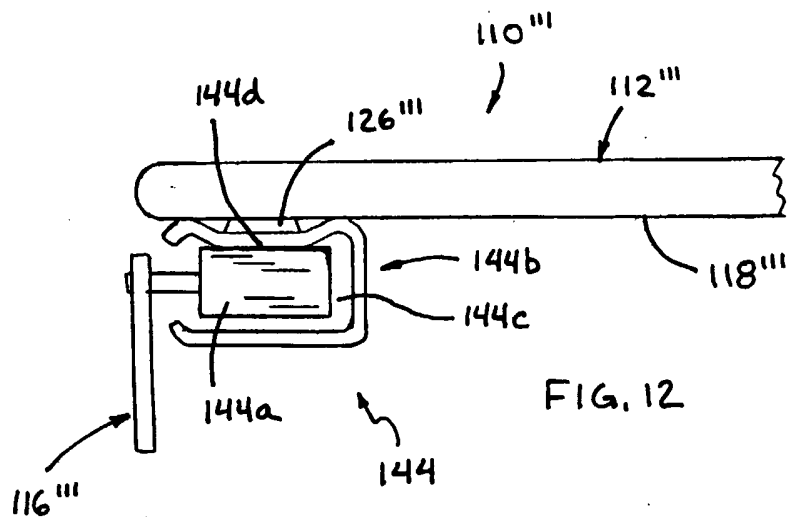

FIG. 15



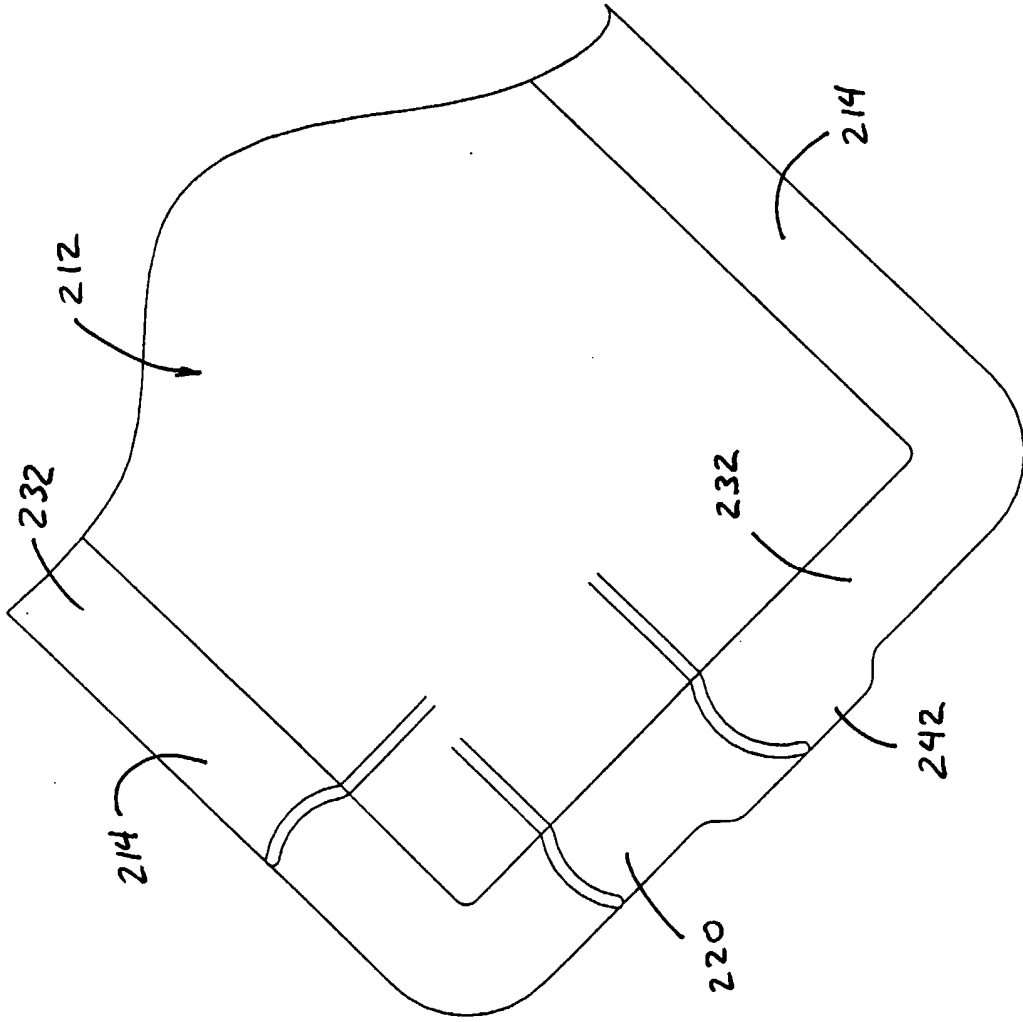

FIG. 16





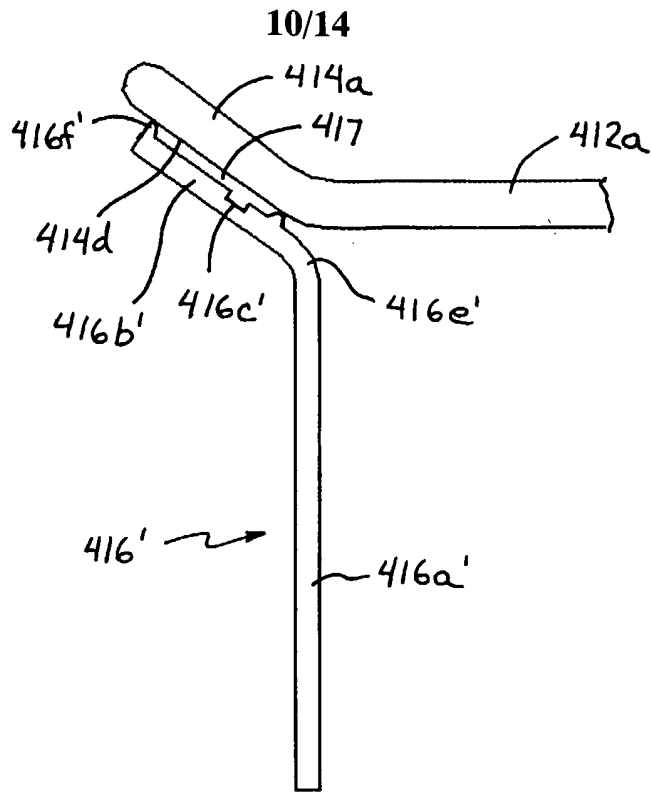

FIG. 19

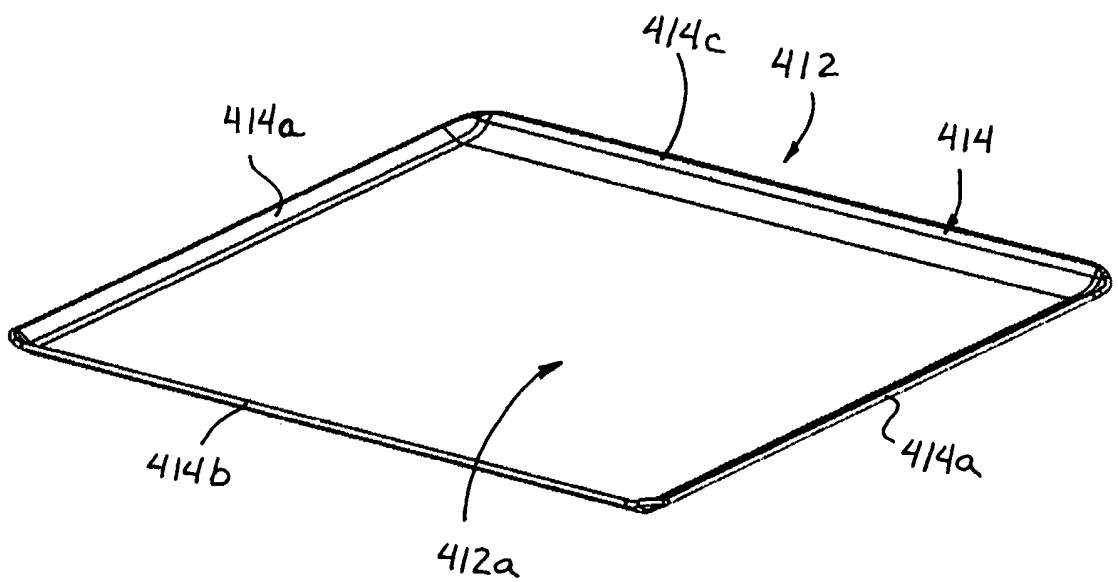

FIG. 20

11/14

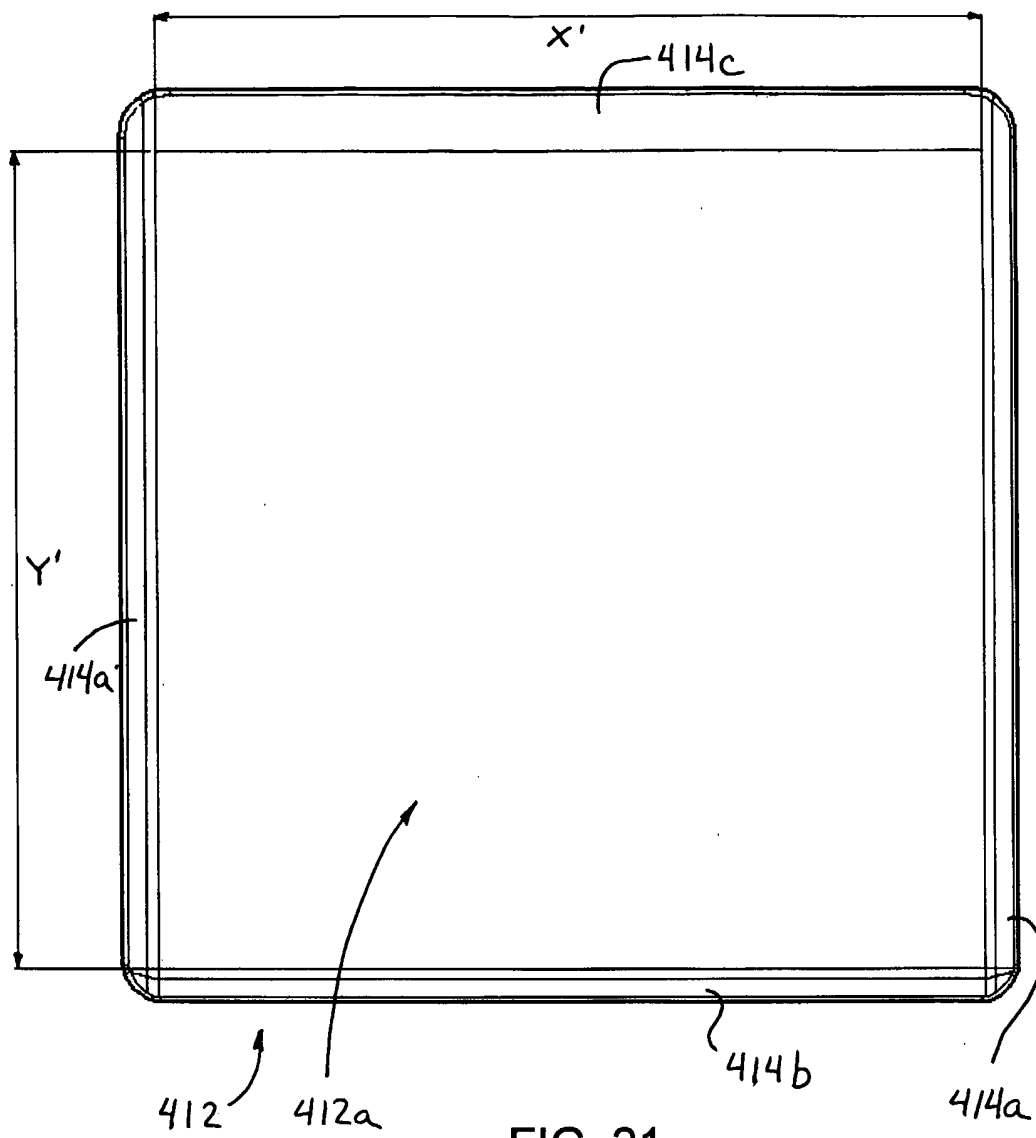

FIG. 21

12/14

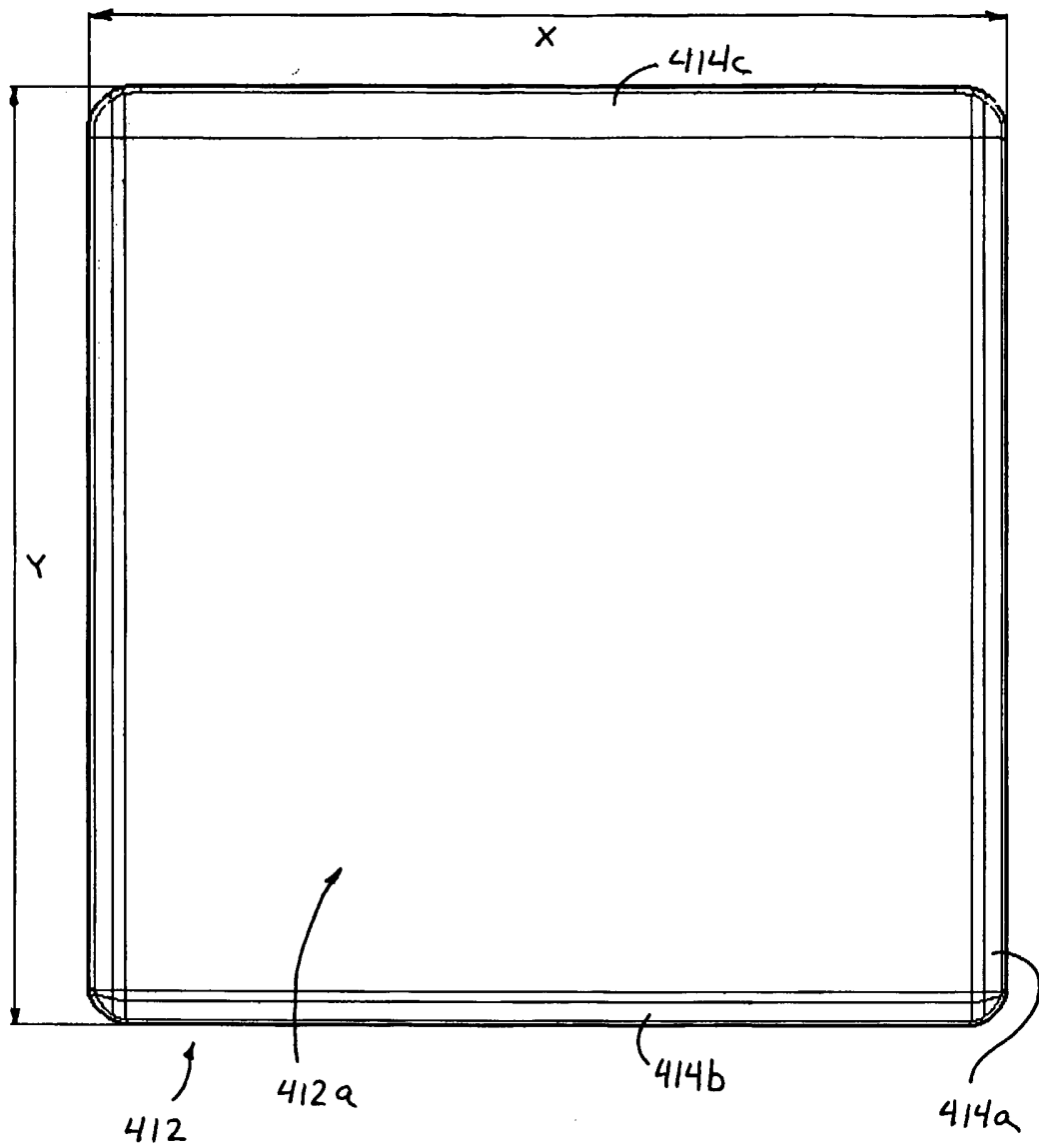

FIG. 22

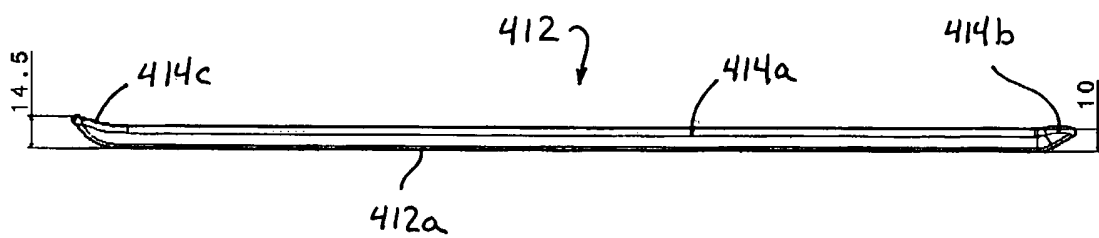

FIG. 23

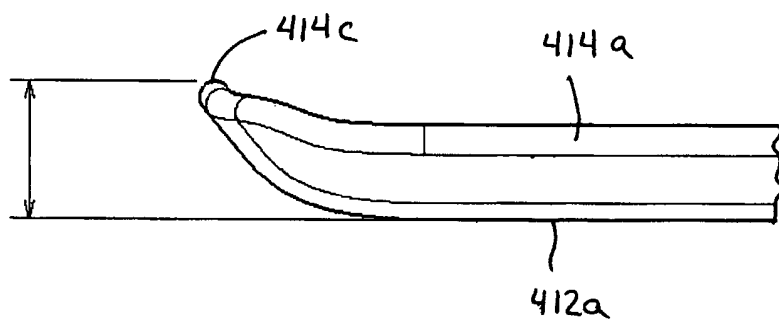

FIG. 24

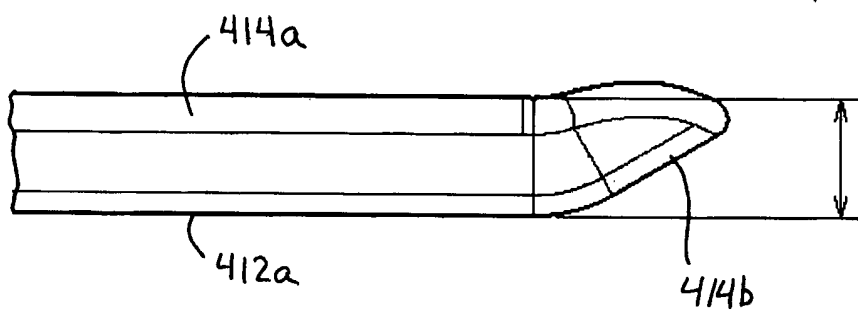

FIG. 25

14/14

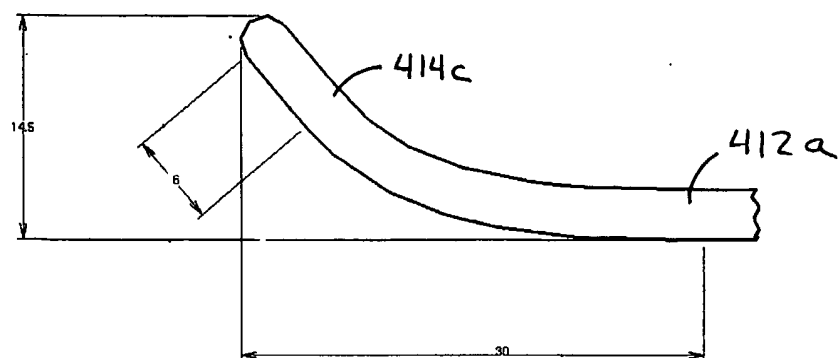

FIG. 26

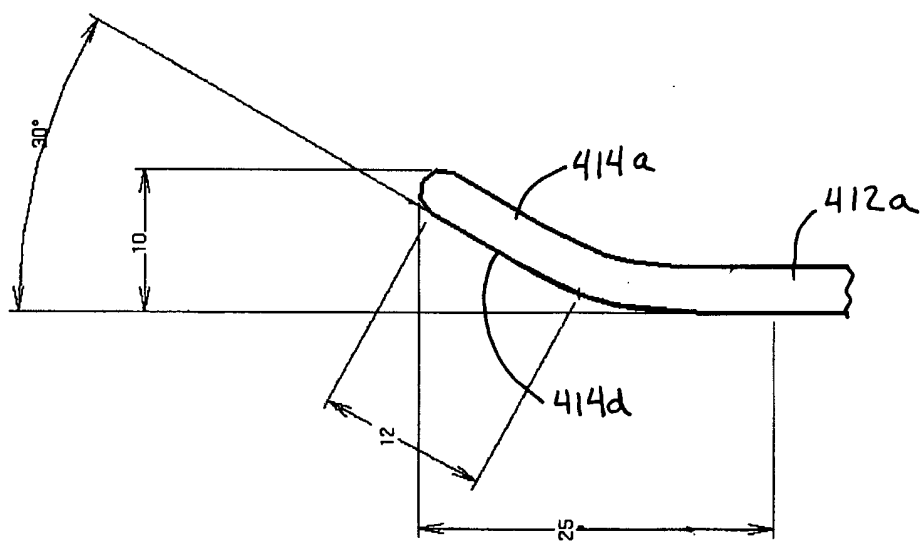

FIG. 27