

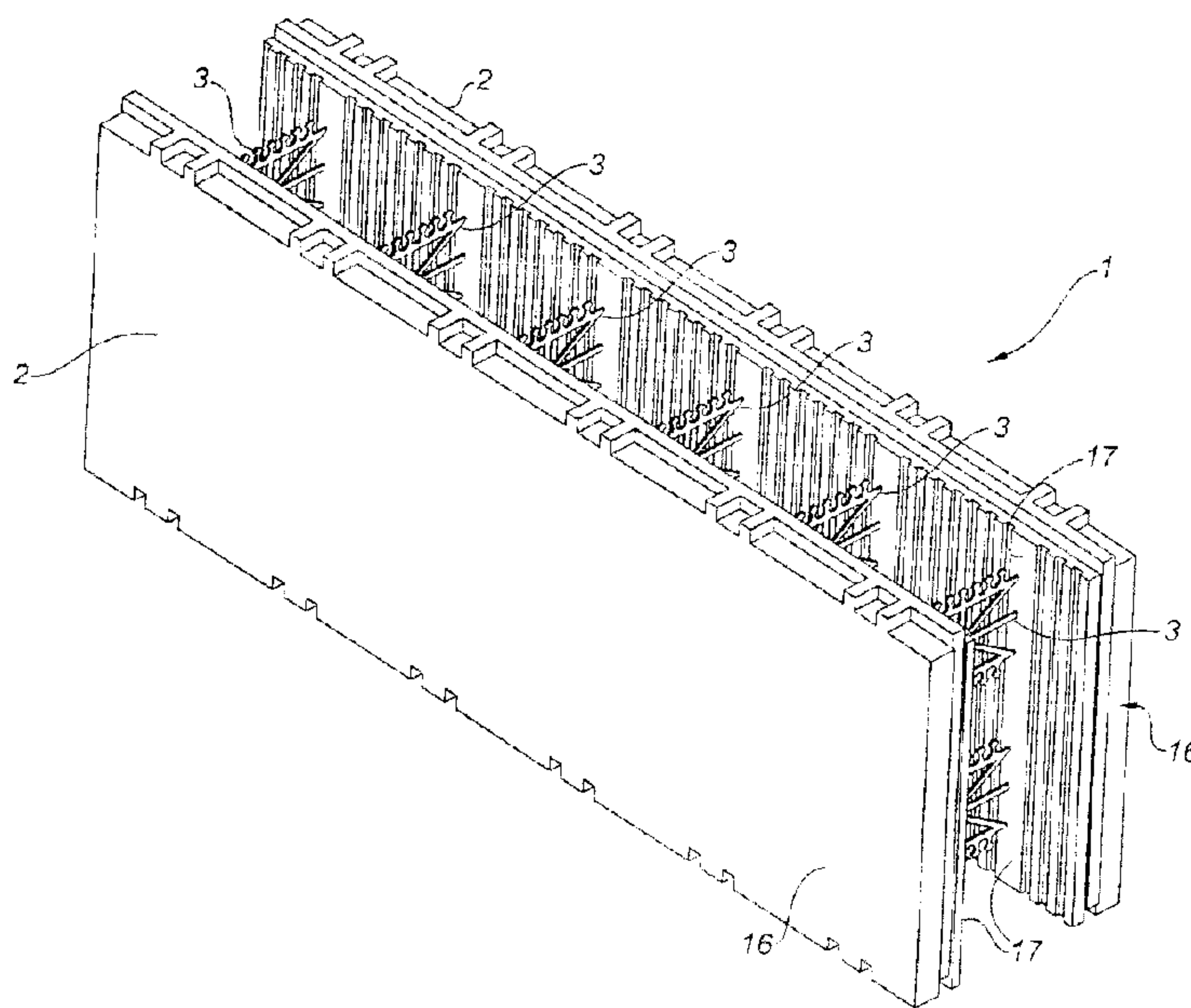

(22) Date de dépôt/Filing Date: 1998/02/09
 (41) Mise à la disp. pub./Open to Public Insp.: 1998/09/17
 (62) Demande originale/Original Application: 2 298 435
 (30) Priorité/Priority: 1997/03/11 (108/814,876) US

(51) Cl.Int.⁷/Int.Cl.⁷ E04B 2/86, E04C 5/16
 (71) Demandeur/Applicant:
 ADVANTAGE WALLSYSTEMS INC., CA
 (72) Inventeurs/Inventors:
 CYMBALA, PATRICK M., CA;
 CYMBALA, ANDREW W., CA;
 MACRAE, ALLAN M.R., CA
 (74) Agent: THOMPSON LAMBERT LLP

(54) Titre : SYSTEME DE COFFRAGE ISOLANT DE BETON
 (54) Title: INSULATING CONCRETE FORM SYSTEMS



(57) **Abrégé/Abstract:**

A concrete form foam block, of an Insulating Concrete Form System, comprises a pair of opposed and parallel foam panels spaced using a plurality of plastic ties. Each tie comprises full panel height flanges which engage the panels and a web portion extending therebetween. The web comprises a plurality of horizontal members; preferably four or more, which are distributed substantially along the full height of the flanges. The web includes a pair of full height anti-flash members for preventing the escape of flash during formation of mould-in panels. The top edges and bottom edges of each panel are formed with longitudinal tongues and grooves which interlock with adjacent blocks. Preferably additional transverse top tongues and complementary bottom grooves are located at each tie, forcing the alignment of vertically adjacent block's flanges. The combination of full height and aligned flanges results in a substantially continuous flange for the attachment of finishing materials. Preferably, indicia are provided, seen from the outside of the panel, for locating the position of the flanges. The same tie can be used in both a moulded-in or a slide-in configuration. Slide-in panels are formed with "T"-shaped slots amenable to accept the flanges of the ties.

1 ABSTRACT OF THE DISCLOSURE

2

3 A concrete form foam block, of an Insulating Concrete Form System,
4 comprises a pair of opposed and parallel foam panels spaced using a plurality of plastic
5 ties. Each tie comprises full panel height flanges which engage the panels and a web
6 portion extending therebetween. The web comprises a plurality of horizontal members,
7 preferably four or more, which are distributed substantially along the full height of the
8 flanges. The web includes a pair of full height anti-flash members for preventing the
9 escape of flash during formation of mould-in panels. The top edges and bottom edges of
10 each panel are formed with longitudinal tongues and grooves which interlock with adjacent
11 blocks. Preferably additional transverse top tongues and complementary bottom grooves
12 are located at each tie, forcing the alignment of vertically adjacent block's flanges. The
13 combination of full height and aligned flanges results in a substantially continuous flange
14 for the attachment of finishing materials. Preferably, indicia are provided, seen from the
15 outside of the panel, for locating the position of the flanges. The same tie can be used in
16 both a moulded-in or a slide-in configuration. Slide-in panels are formed with "T"-shaped
17 slots amenable to accept the flanges of the ties.

"INSULATING CONCRETE FORM SYSTEM"**FIELD OF THE INVENTION**

The present invention relates to concrete construction utilizing foam block forms, more specifically to improvements to the foam panels, panel spacing ties and the interaction of the ties with the foam panels.

BACKGROUND OF THE INVENTION

Insulating Concrete Form Systems ("ICFS") are known which act as a form to contain the fluid concrete while it solidifies, and also provide insulation for the finished structure. ICFS utilise a plurality of individual units or blocks, assembled in an interlocking arrangement, to create the forms for the concrete walls. Each block comprises a pair of foamed plastic panels, which are held together with a plurality of ties.

The ties are truss-like and comprise flange portions which reside within the foam panels and an intermediate web portion connecting the flange portions, thus securing and holding the panel portions. One such example is disclosed in US Patent No. 4,229,920 to Lount, issued October 28, 1980 who teaches use of a block having a multi-component tie.

More contemporary ICFS designs have implemented ties having integral flanges and web portions. Examples of this construction include US Patent No. 5,390,459 to Mensen, US Patent No. 4,884,382 to Horobin and US Patent No. 4,731,968 to Obino. In an application to Sparkman in WO 95/23899, an insulated concrete form ("ICF") block of the post and beam variety is disclosed. Sparkman's tie has flanges which extend to the outside face of the block. The top and bottom extents of the flanges incorporate a hook and catch arrangement to hold vertically adjacent blocks together and avoid lifting or float of vertically stacked blocks.

1 Horobin teaches slide-in ties which have complementary flanges and "T"
2 slots formed in the panels. Each slot extends from the top of the panel to a point just lower
3 than the mid-point. Accordingly, both the tie and the flange portions of the tie are
4 substantially less in height than the panel. The flange itself has an "H" profile in plan; the
5 outer portion for engaging the panel's "T"-slot, and the inner portion for stabilizing the inner
6 face of the panel. The tie's web comprises three horizontal tension members, joined
7 together at the flanges.

8 Obino provides a tie similar to Horobin, but the flanges are moulded into the
9 foam of the panel. Both the web and flanges are substantially shorter than the panels.
10 The web structure is continuous; lacking any holes.

11 In Mensen, the tie is moulded into the panel with the flange located flush
12 with the outside of the panel. The flange extends substantially the full height of the panel.
13 In side view, the tie resembles an "H", the horizontal dash representing the web portion
14 being much narrower than the flanges. Diagonal gussets extend from the web's midpoint
15 to points adjacent the distal ends of each flange.

16 These above designs result in non-optimal distribution of the hydrostatic
17 stress of the fluid concrete across the narrow central web portion of the tie and in the upper
18 and lower portions of the foam panels. In Horobin and Obino, the foam portion is
19 completely unsupported by the tie at the panel's upper and lower ends. In Mensen, the
20 tips of the flanges are inadequately supported by the gussets. The result is excessive
21 deformation of the top and bottom portions of the foam panels when filled with concrete.
22 This is especially apparent when high vertical concrete lifts (a full; 8' high wall) are poured
23 in a single stage.

1 Mensen, Horobin and Obino permit attachment of interior and exterior
2 surface finishing materials such as drywall or siding to the vertically-oriented flange
3 portions of the ties. Of these three designs, only Mensen provides a flange which extends
4 substantially the full height of the panels and is visible from outside the block for ease of
5 attaching fastening devices.

6 Conventional systems permit vertical misalignment such that the flanges of
7 adjacent blocks are not always aligned vertically. This poses difficulties for installers who
8 need to accurately locate the flanges when attaching finishing materials

9 Within the typical dimensions of building construction there is frequently the
10 need for a half-height concrete form block to be used, for example, below and above
11 window openings. Although some ICFS designs provide a custom block having a less-
12 than-standard height, none of the existing designs permits a block to cut horizontally in half
13 to create a "half-height" block which continues to provide independently structurally sound
14 characteristics.

15 In summary, the blocks of conventional systems, as described above, have
16 the following features in common:

- 17 - a pair of substantially rectangular foamed plastic panels;
- 18 - two or more ties which extend across the space between panels for
19 securing the panels in opposing, parallel, and spaced orientation, the
20 spacing forming a cavity therebetween for containing the fluid
21 concrete while it solidifies;
- 22 - the web portions of the ties being substantially less in height than the
23 panels; and
- 24 - means associated with the edges of the panels for engaging

1 cooperating means on adjacent blocks in order to assemble the
2 complete wall form system.

3 **Disadvantages associated with the above systems include:**

- 4 - inadequate support of hydrostatic pressures;
- 5 - deficient flange configuration, being either,
 - 6 - that they are too short to provide a convenient support upon
 - 7 which to mechanically fasten finishing materials as in Horobin
 - 8 and Obino, or
 - 9 - that they cause interruption of the integrity of the outer face of
 - 10 the panel, compromising adhesion of surface mount
 - 11 materials like stucco, as is the case in Mensen; and
- 12 - permitting misalignment of flanges between vertically adjacent
- 13 blocks, further complicating the mechanical fastening of the finishing
- 14 materials.

15 **Despite attempts to solve various shortcomings of the conventional blocks,**
16 **the applicant is not aware of a system which provides sufficient strength to competently**
17 **support the hydrostatic head of a full-height wall of fresh concrete, and enables convenient**
18 **attaching of finishing materials.**

SUMMARY OF THE INVENTION

1
2 The apparatus of the present invention avoids the structural weaknesses
3 associated with the ties of the prior art and increases the versatility of the ties and blocks.

4 Prior art ties are designed, in part, to accommodate poor concrete
5 placement practice. Practised for many years, one characteristic of low quality concrete
6 mixing and placement practice has been to pour concrete from a minimum number of
7 locations and rely on lateral flow to distribute the concrete along the length of the forms.
8 To facilitate this lateral flow, the concrete was often mixed with an excessively high water
9 content, resulting in poor concrete quality. To further facilitate lateral concrete flow, it has
10 also been traditional practise to minimise the height of the ties inside the forms so as to
11 provide the least obstruction to flow along the form. As described above, this tie design
12 results in a weaker ICFS block.

13 In contradistinction, It is known that concrete should be mixed with the
14 minimum amount of water necessary for proper chemical hydration of the cement. This
15 "low-slump" concrete, which does not readily flow, provides significantly higher ultimate
16 strength and reduces shrinkage and cracking of foundations. Further, modern placement
17 equipment enables vertical placement of concrete into the forms from many closely
18 spaced locations, eliminating the reliance on lateral flow.

19 Accordingly, and contrary to the conventional wisdom, in a first embodiment
20 of the invention, a novel ICFS block is provided having a tie which incorporates flanges
21 which extend substantially the full height of the panels, and have a plurality of horizontal
22 tensile web members which are distributed substantially along the full height of the flanges.

23 The members uniformly resist horizontal forces generated by the fluid concrete acting on
24 the foam panels.

1 Preferably at least two horizontal members are located above the web's
2 midpoint and two below. For instance, one can produce two independently structurally
3 sound half-height blocks if cut laterally in half. Sufficient open area is provided through the
4 tie to permit lateral concrete flow to occur across the ties so as to form an integral concrete
5 mass.

6 Complementary tongue and groove features are formed into the top, bottom
7 and end edges of the panels to enable interlocking of adjacent blocks.

8 In a first broad aspect of the invention then, a concrete form block is
9 provided comprising:

- 10 - a pair of rectangular foam plastic panels having inner and outer
11 faces, top and bottom and end edges;
- 12 - at least two ties spaced longitudinally and parallel from each other,
13 each of which extend perpendicularly between the inner faces of the
14 panels so as to space the panels in opposing and parallel orientation,
15 each tie having two opposed flange portions and a web portion
16 extending therebetween, each flange portion forming a vertical stud
17 which extends substantially the height of the panels and is moulded
18 within each panel, the web portion comprising a plurality of
19 horizontally extending members distributed substantially along the
20 full height of the flanges, the web having a majority of its cross-
21 sectional area comprising open space; and
- 22 - interlocking means along the edges of the panels so that the block
23 interlocks with other blocks when placed adjacent one another.

24 In a second aspect of the invention, the top edges of each panel are formed

1 with additional transverse tongues at the location of each tie. Complementary transverse
2 grooves are formed in the bottom edges. The transverse tongues and grooves cooperate
3 to force vertically adjacent blocks to always interlock such that the flanges of their
4 respective ties are aligned. The combination of the full height aligned flanges result in a
5 substantially continuous flange for the attachment of finishing materials. Preferably, indicia
6 are provided, seen from the outside of the panel, for locating the position of the flanges.

7 The flanges of the tie reside wholly within the body of the panel. The
8 plurality of the tie's horizontal members extend from the flanges, which are located within
9 the panel, and pass through the block's cavity. For a moulded-in embodiment, this
10 arrangement imposes a difficult task upon the moulding process so as to prevent the
11 escape ("flash") of panel-forming foam from between the horizontal members and into the
12 cavity.

13 Accordingly, in a third aspect of the invention, it is preferable to include an
14 anti-flash member for forming a continuous barrier between all the members at the
15 interface of the panel's inner face and the block's cavity. The anti-flash member
16 comprises a light member which extends substantially the entire height of the tie, offset
17 from the flange sufficiently so as to correspond with the inner face of the panel. The
18 member is non-structural and merely strong enough to restrain flash.

1 **Figure 7 is a perspective view of a plurality of blocks, of either embodiment,**
2 **assembled for illustration of the vertical alignment of flanges.**

3 4 **DETAILED DESCRIPTION OF THE PREFERRED EMBODIMENT**

5 **Having reference to Figure 1, one block 1 of an Insulating Concrete Form**
6 **System ("ICFS") is shown. A plurality of blocks 1 are laid adjacent each other,**
7 **longitudinally end-to-end and vertically row-by-row (Figure 7). For strength, each**
8 **successive row has the ends of each block offset from the ends of the blocks in the**
9 **adjacent rows.**

10 **In conventional and the novel systems, each block 1 comprises two**
11 **rectangular foam panels 2 typically formed of expanded polystyrene. Each panel 2 has an**
12 **outer face 16 and an inner face 17. Two or more ties 3 (six shown) extend transversely**
13 **between the panel's inner faces 17 to locate the panels 2 in parallel opposed and spaced**
14 **relation to each other. The ties 3 are spaced longitudinally and parallel to each other along**
15 **the panels 2.**

16 **Having reference to Figures 2a through 3, each tie 3 comprises two laterally**
17 **opposed flange portions 4 and a web portion 5 extending therebetween. Typically a tie is a**
18 **unitary plastic structure of high density polyethylene or polypropylene.**

19 **Each flange 4 engages one of the opposed panels 2 and prevents lateral**
20 **movement relative to the opposed panel 2.**

21 **Flanges 4 also serve as a structure to which finishing materials may be**
22 **secured. Shown in exploded view in Fig. 2a, sheeting material 6 is attached to the flanges**
23 **4 with mechanical fasteners 7.**

1 Thus far, the description of the block of a ICFS is also descriptive of the
2 prior art systems.

3 In a first embodiment of the present invention, a novel ICF System is
4 provided in which novel ties 3 and complementary panels 2 are formed in a moulded-in
5 configuration. The same tie 3 (Figure 3) is also amenable to a slide-in application as
6 disclosed in a further embodiment discussed later.

7 Tie 3 has a web portion 5 and opposing flange portions 4. The flange 4
8 forms a "T"-shape in section. The outermost portion the "T" 8 lies parallel to the plane of
9 the panels 2.

10 The height of each flange 4 is substantially equal to the full height of the
11 panels 2. As shown in Figure 7, when the ties 3 are aligned with the ties 3 of blocks 1 in
12 adjacent rows, the full-height flanges 4 form a nearly continuous structure 15 upon which
13 to attach and support finishing materials, such as drywall or siding.

14 The flanges 4 are structurally maintained in a spaced apart and parallel
15 relation by the tie's web 5. The web 5 comprises a plurality of members 9 extending
16 horizontally between flanges 4. The horizontal members 9 are distributed vertically
17 between the flange's top 10 and bottom 11. At least two members 9 (3 are shown) are
18 located above the mid-point M of the web, and at least two members 9 (3 shown) below.
19 Should the ICFS block be cut laterally in two or more pieces, at least two horizontal
20 members 9 remain above the cut and at least two members 9 will remain below the cut,
21 thereby providing independent and structurally sound part-height blocks (not shown).

22 Diagonal members 12 in the web provide torsional stiffness.

1 The overall cross-section of the horizontal members 9 is sized to withstand
2 hydrostatic pressure of fluid concrete pressing laterally outwardly on the inner faces 17
3 of the panels 2 without causing excessive panel deflection. Using six plastic ties 3,
4 spaced along a 1-1/3' high x 4' (40x120 cm) long panel, and wherein each tie 3 has six
5 horizontal members 9 which are about 0.25" high (0.6 cm) x 0.20" (0.5 cm) in section,
6 the block's panels 2 can withstand a pressure of a height of eight feet of concrete
7 poured at once.

8 The plurality of members 9 extending between flanges poses a challenge
9 during the moulding process. Along a plane where the inner face 17 of the panel 2
10 forms, the tie 3 comprises an alternating pattern of members 9 and space 13. For
11 properly forming foam panels, the moulding equipment must successfully restrain the
12 flow of foam ("flash") about each member 9 to limit its escape.

13 Accordingly, thin flatbar-like anti-flash members 14 extend the height of
14 the web 5 and with their cross-sectional plane lying parallel to the flanges 4. The anti-
15 flash members 14 bridge the open space 13 between members 9 so as to form a
16 continuous barrier. The anti-flash members 14 are non-structural and merely block foam
17 from escaping during the moulding process. The anti-flash members are spaced
18 sufficiently inwardly from each of the flanges so as to cooperate with moulding
19 equipment and align with the inner face 17 of the panel 2. Typically, for a panel
20 thickness of 2-1/2" (6.25 cm), the flange 4 is inset about 3/8" (1 cm) from the outer face
21 of the foam panel, and the anti-flash 14 members are spaced about 2-1/8" (5.3 cm) from
22 the flanges.

23 Once moulded-in, the ties 3 and panels 2 form a unitary block 1 of an
24 ICFS.

1 Tongue 20 and grooves 21 are provided at the block's two ends 28,29 to
2 interlock panels 2 together and prevent transverse misalignment. At one end 28 of the
3 block 1, the two ends of the panels 2 have opposing interlocking means 20,21; in other
4 words, the end of one panel forms a tongue 20 and the end of the other forms a groove
5 21. In this way, full blocks 1 are not restricted to one mode of abutment with adjacent
6 blocks.

7 Longitudinally extending tongues 22 protrude upwardly from the top edge
8 24 of both panels 2. The tongues 22 avoid collecting moisture and ice prior to assembly.
9 Corresponding longitudinal grooves 23 are formed in the bottom edges 25 of the panels
10 for interlocking with the top edge tongues 22 of a lower row of blocks 1.

11 At each longitudinal location of a tie 3, one or more short tongues 26
12 extend transversely from the top tongue 22. These short tongues 26 correspond with
13 short transverse grooves 27 in the block's bottom edge 25. The short tongue 26 and
14 grooves 27 cooperate to longitudinally locate the blocks of one row so that their ties 3
15 must align vertically with the ties 3 in the adjacent upper and lower rows.

16 The short tongue and grooves 26,27 extend to the outer face 16 of each
17 panel 2 and thus visibly indicate the location of each tie 3 (Fig. 1). The tongue and
18 grooves 26,27 are arranged as corresponding pairs. Preferably, two tongue 26,26 and
19 grooves 27,27 are placed in closely-spaced arrangement. As shown in Figs. 2a and 4,
20 the two tongues and grooves of a corresponding pair 26,27 are approximately arranged
21 or straddle the dimensional periphery of the tie 3.

22 Alternatively, indicia lines or embossing is applied to the panel's outer face
23 16 to visibly indicate the location of the tie 3. As shown on Figs. 4 and 7, indicia lines
24 delineate the continuous structure 15 on vertically adjacent blocks 1. Further, the indicia

1 can delineate the dimensional extent of the flange 4. Best shown in Fig. 4, the indicia is
2 formed using an embossing or bas relief formed into the outer face 16 of the panel 2.

3 As shown in Figure 4, the invention is equally well applied to a corner
4 block 40.

5 Moulded-in tie blocks provide the advantage of avoiding work-site
6 assembly. Unfortunately, such blocks are more expensive to fabricate and occupy more
7 space and are therefore more costly to ship to remote construction sites.

8 Accordingly, in a second embodiment and having reference to Figure 5, it
9 is desirable to provide block 30 which uses panels 31 and ties 3 which can be
10 unassembled to form a more compact shipping unit.

11 Panels 31 are moulded without ties 3. A plurality of "T"-type slots 32 are
12 formed in the panels 31. One "T" slot 32 is provided for each tie 3. The ties 3 are
13 identical with those described for the first embodiment. Each slot 32 extends from the
14 top edge 33 of the panel 31 to a point 34 adjacent the bottom edge 35 of the panel so as
15 to accommodate the height of the tie's web 5.

16 Referring to Figure 6, the outermost portion 36 of each "T" slot 32 is
17 aligned longitudinally with the panel 31. The stem 37 of the "T" extends to the inner face
18 of the panel 31.

19 The outermost portion 8 of the tie's flanges 4 (Fig. 3) slide into each "T"
20 slot. The depth of the "T" slot 32 in the body of the panel 31 is coordinated with the tie's
21 flange 4 and anti-flash member 14 so that the anti-flash members 14 do not substantially
22 interfere with the panel 31 itself.

23 The use of a single tie 3 is preferable for both moulded-in and the modular
24 slide-in tie embodiments. The single tie design is cost effective due to both the

1 economies of scale in manufacturing a dual-purpose tie and due to reduced inventory
2 costs.

3 The advantages achieved by the novel tie and panel system include:

- 4 • the substantially full height web permits use of a plurality of horizontal
5 web members distributed over the height of the flanges for
6 strengthening the flanges against hydrostatic pressures;
- 7 • full height flanges provide ample area for the attachment of finishing
8 materials;
- 9 • the forced alignment of flanges across successive rows of blocks
10 ensures ease locating the flanges and installing finishing materials;
- 11 • provision of two or more horizontal members above and two or more
12 below the tie mid-point permits a block to be cut in two or more pieces
13 for increased versatility in assembly; and
- 14 • the same tie can be used in both a moulded-in and a slide-in
15 application.

16

1 **THE EMBODIMENTS OF THE INVENTION IN WHICH AN EXCLUSIVE**
2 **PROPERTY OR PRIVILEGE IS CLAIMED ARE DEFINED AS FOLLOWS:**

3

4 1. A concrete form block (1) which is stackable side-by-side and
5 vertically above and below with other adjacent concrete form blocks (1), each block
6 having a pair of rectangular foam plastic panels (2) having an inner face (17) and an
7 outer face (16), top edge (24), bottom edge (25) and longitudinal end edges (28,29),
8 first connectors (20,21) along the longitudinal end edges of the panels so that the
9 block interlocks with other blocks when placed adjacent one another, and at least two
10 ties (3) spaced longitudinally and parallel from each other, each of which extend
11 perpendicularly between the inner faces of the panels so as to space the panels in
12 opposing and parallel orientation, each tie having two opposed flange portions (4) and
13 a web portion (5) extending therebetween,

14 characterised in that:

15 the tie flange portions extend substantially the height of the panels (2)
16 and lie between the inner and outer faces (17,16) of the panels (2); and

17 second connectors (26,27) are located along the top edge of the
18 concrete foam panels and along the bottom edge of the concrete foam panels
19 respectively so that when the adjacent blocks (1,1) are stacked vertically, the
20 adjacent blocks cannot be stacked unless the second connectors align, forcing the
21 flanges of the ties of the vertically adjacent blocks to align and form a substantially
22 continuous vertical flange (15).

23

1 2. The concrete form block of claim 1 wherein the second connectors
2 (26,27) comprise:

3 two or more pairs of corresponding tongue (26) and grooves (27) spaced
4 along the top and bottom edges of the concrete foam panels, the tongues and
5 grooves extending transverse to the concrete foam panel,

6 the tongues (26) protruding upwardly from the top edge of the concrete
7 foam panels,

8 the grooves (27) being recessed in the bottom edge of the concrete
9 foam panels, and

10 the spacing of the pairs of corresponding tongue and grooves (26,27)
11 being such that the concrete foam panels cannot be stacked unless the tongue and
12 grooves align to force the concrete foam panels into an orientation in which the at
13 least two ties between the first pair of concrete foam panels are aligned with the at
14 least two ties between the second pair of concrete foam panels.

15
16 3. The concrete form block as recited in claim 2 wherein there are as
17 many pairs of corresponding tongue and grooves (26,27) as there are ties (3).

18
19 4. The concrete form block as recited in claim 3 wherein one pair of
20 corresponding tongue and grooves (26,27) is positioned correspondingly at each tie
21 (3).

22

1 5. The concrete form block as recited in claim 4 wherein each pair of
2 corresponding tongues and grooves (26,27) comprises

3 two closely spaced tongues (26,26), one tongue positioned at each of
4 the two longitudinal peripheral edges of the flange of the corresponding tie, each
5 tongue extending outwardly to the panel's outer face; and

6 two closely spaced grooves (27,27), corresponding to the two closely
7 spaced tongues (26,26) and extending outwardly to the panel's outer face, wherein the
8 tongues and grooves (26,26,27,27) are visible at the outer face of the panel and
9 delineate the location of the continuous vertical flange (15).

10
11 6. The concrete form block as recited in claim 4 wherein the outer face
12 of the panel is embossed for visually locating the location of the vertical stud (15).

13
14 7. The concrete form block as recited in claim 6 wherein the embossing
15 comprises a first bas relief surface overlying the flange of a tie, the first surface
16 representing the dimensional limits of the flange and further comprising a second
17 narrower bas relief surface overlying the center of the flange, together the first and
18 second surfaces demonstrating the location of the dimensional limits and the center of
19 the flange.

20
21 8. The concrete form block as recited in claim 2 wherein the flanges (4)
22 of the ties are moulded within the panels (2).

23

1 9. The concrete form block as recited in claim 2 wherein the web
2 portion (5) comprises a plurality of horizontally extending members (9) distributed
3 substantially along the full height of the flanges (4), the web having a majority of its
4 cross-sectional area comprising open space.

5
6 10. The concrete form block as recited in claim 9 wherein the web
7 portion (5) has at least four horizontally-oriented members (9) distributed across the
8 full height of the web (5), at least two of which are located above the web's midpoint
9 (M) and at least two of which are located below the web's mid-point (M).

10
11 11. A method for forming an insulating form wall comprising the steps
12 of:

13 (a) providing a first block (1) and at least a second block (1), each
14 block having a pair of concrete foam panels (2), each panel having inner and outer
15 faces (17,16), top edges (24), bottom edges (25), and longitudinal end edges
16 (28,29), and being secured in an opposing and spaced apart relationship by at least
17 two ties (3) extending between the panels inner faces (17), the ties (3) having
18 opposing vertical flanges (4) located within the panels and a web (5) extending
19 therebetween;

20 (b) providing a connector (26) on the top edge (24) of at least one of
21 the panels of the first block and a complementary connector (27) on the bottom edge
22 (25) of at least one of the panels of the second block, the location of the top and
23 bottom connectors (26,27) being such that, when engaged, the flanges (4) of the ties

1 (3) of the first block (1) and flanges (4) of the ties (3) of the second block (1) must be
2 vertically aligned;

3 (c) stacking the first and second blocks vertically; and

4 (d) engaging the first block's connector (26) with the second block's
5 complementary connector (27), the first and second blocks being unable to stack
6 unless the at least two ties (3,3) of the first block and the at least two ties (3,3) of the
7 second block are vertically aligned and the flanges (4) thereby form a substantially
8 continuous vertical flange (15) between stacked blocks (1,1).

9

10 12. The method of claim 11, wherein one of the connectors (26,27) is a
11 tongue and the complementary connector (27,26) is a groove that engages the
12 tongue.

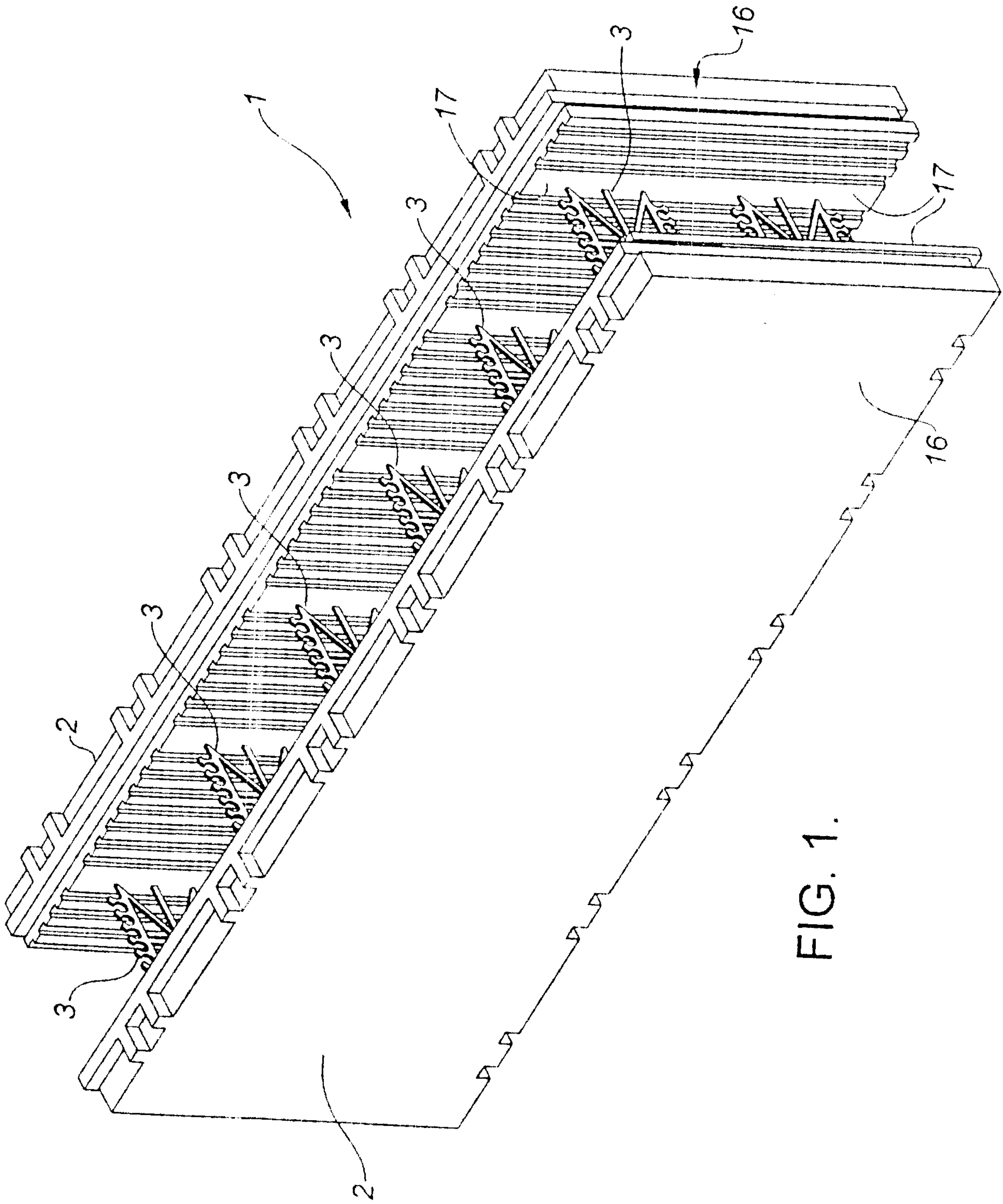

FIG. 1.

2/6

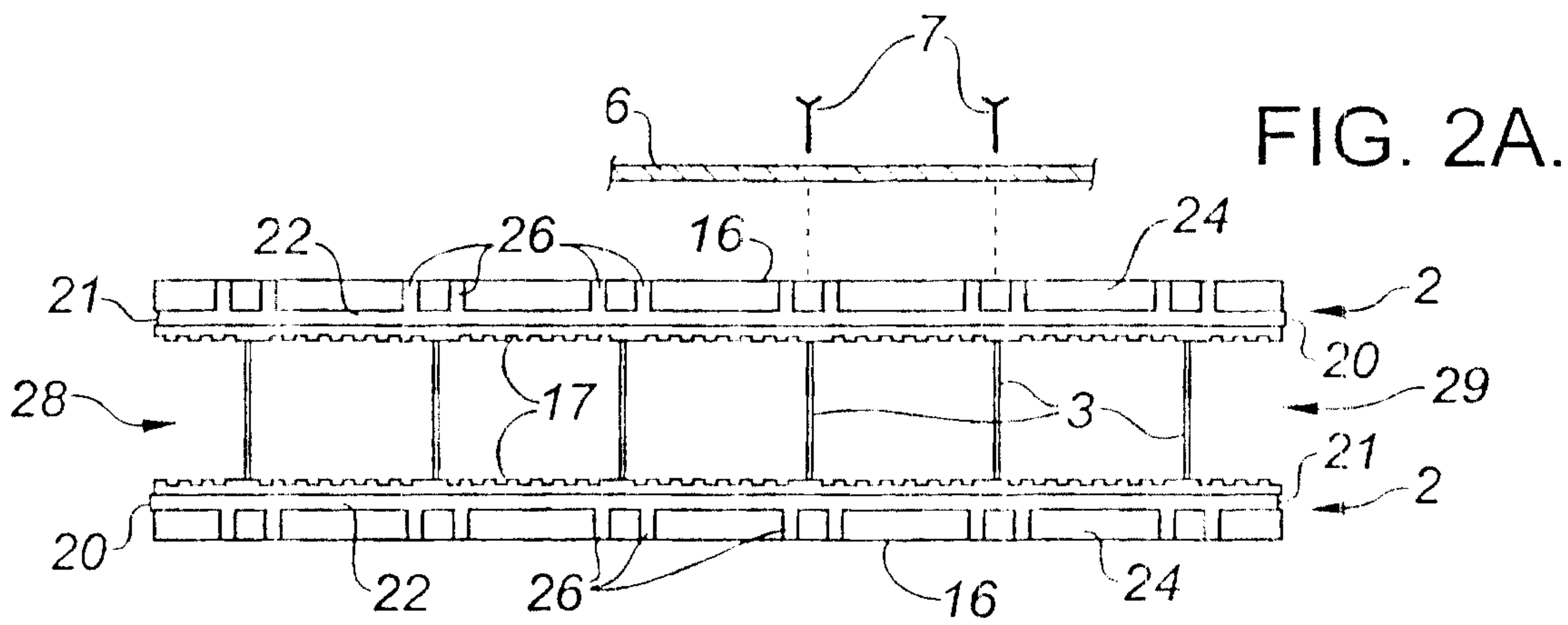

FIG. 2A.

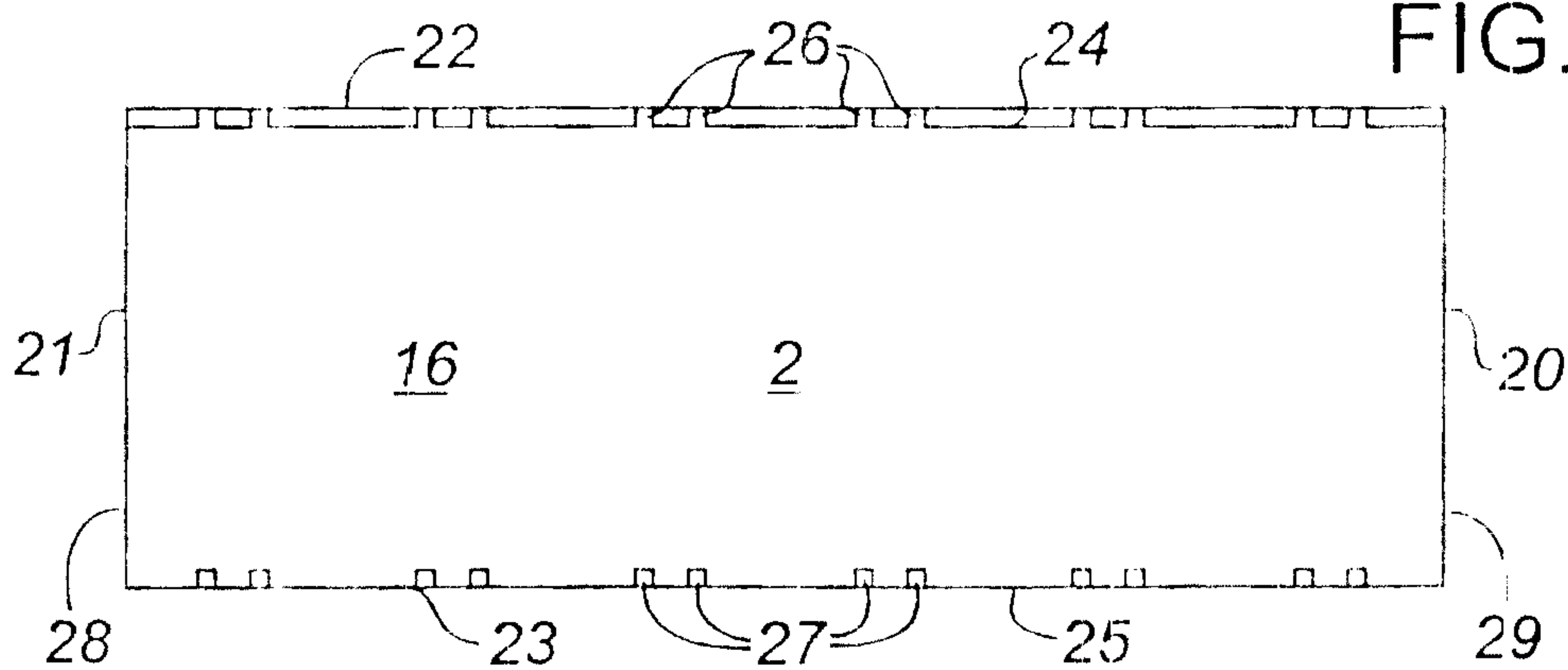

FIG. 2B.

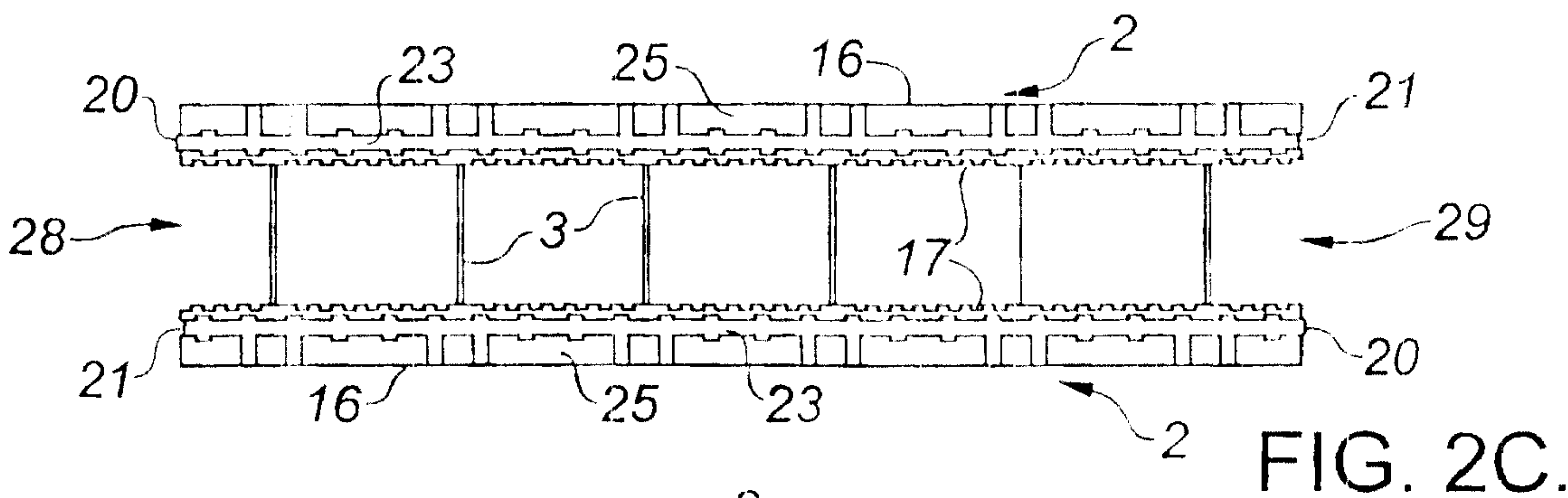

FIG. 2C.

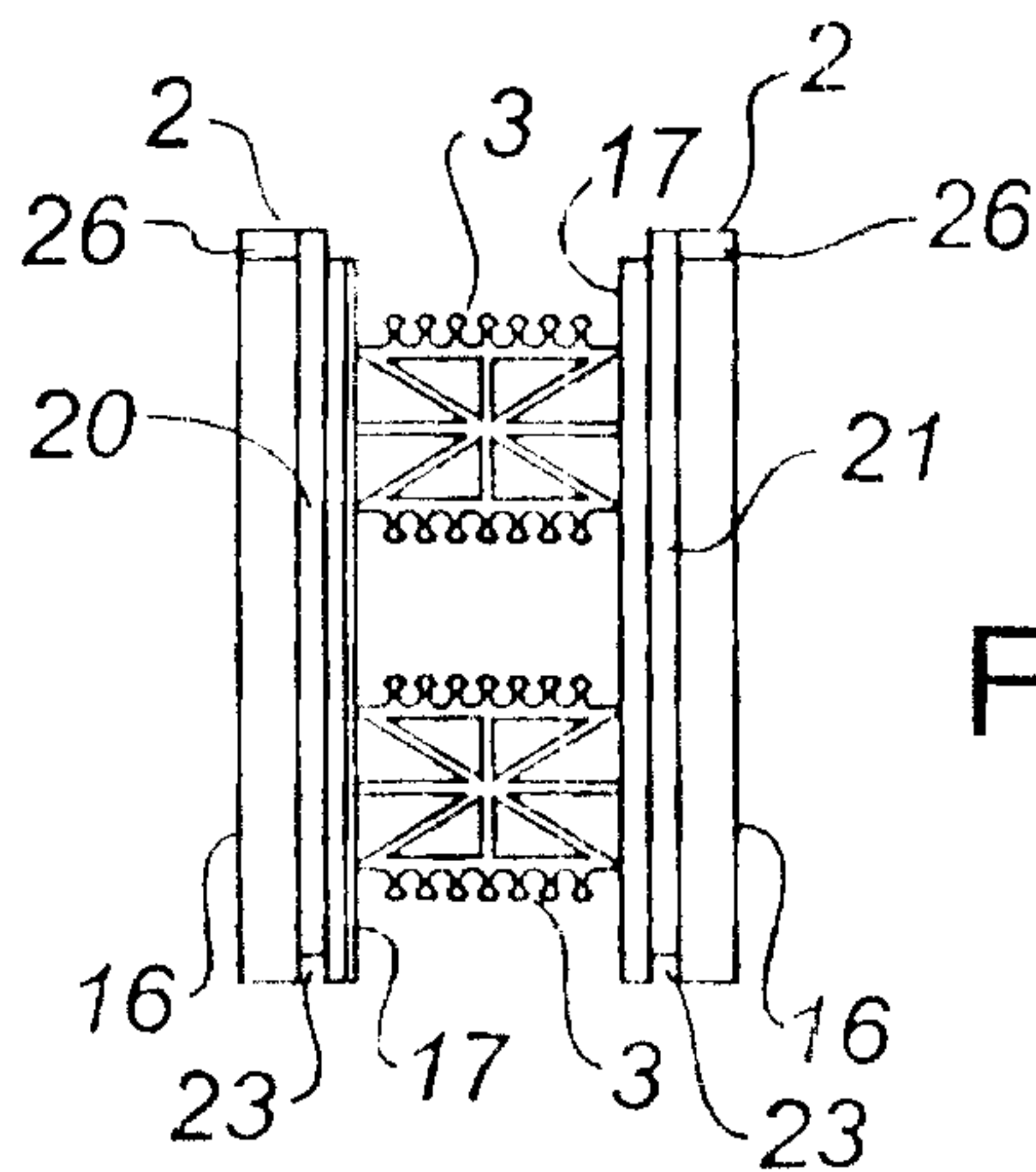

FIG. 2D.

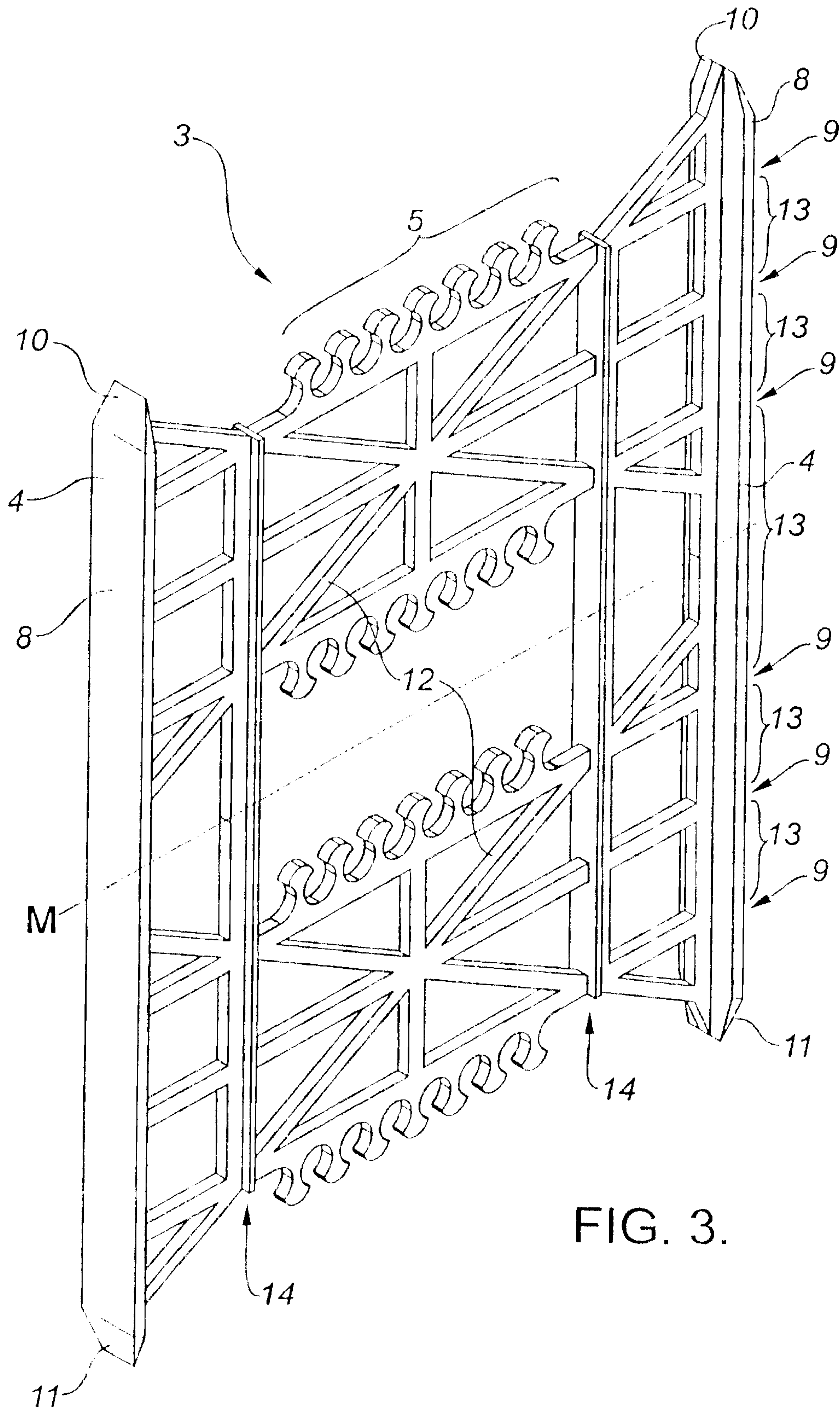

FIG. 3.

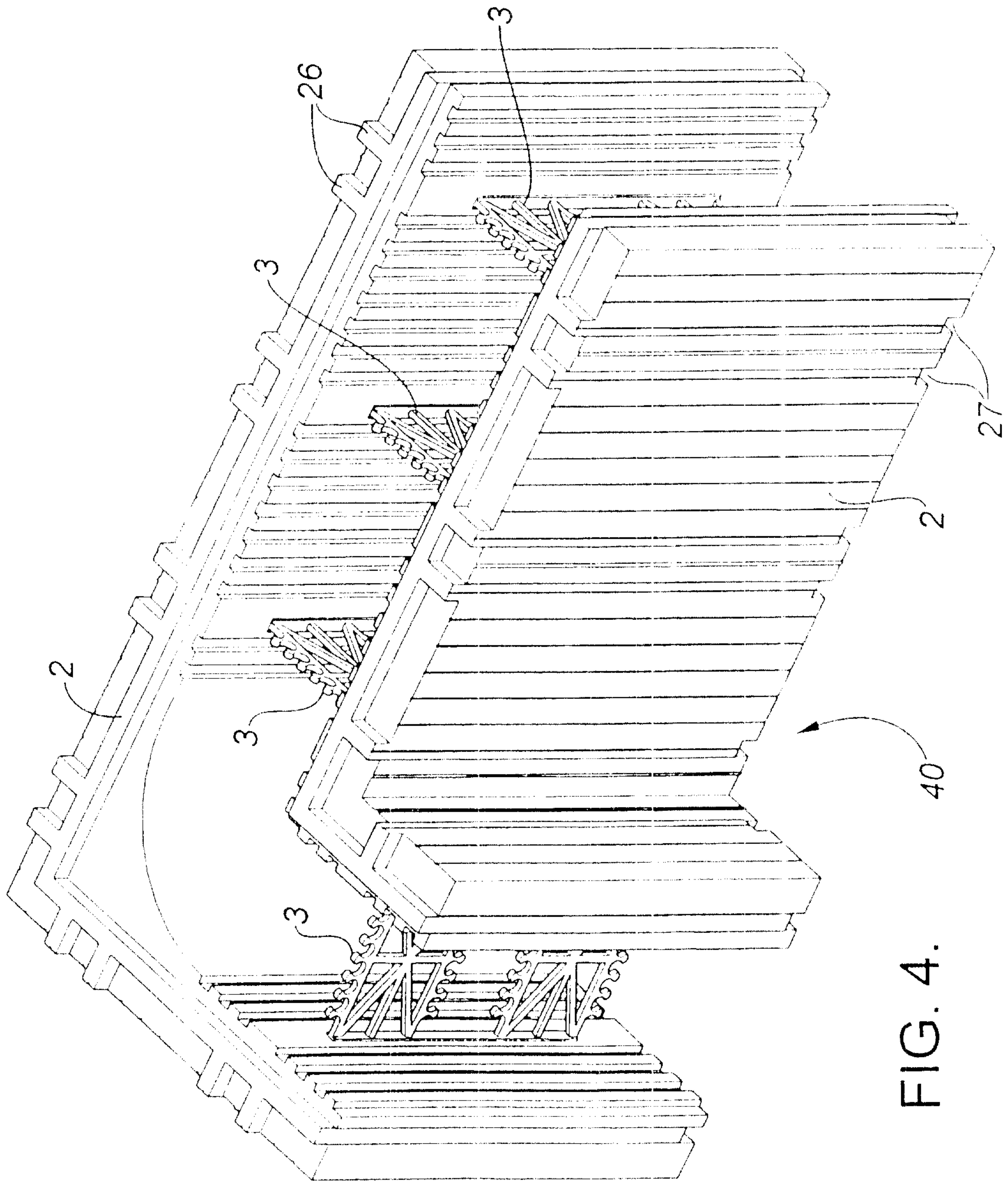

FIG. 4.

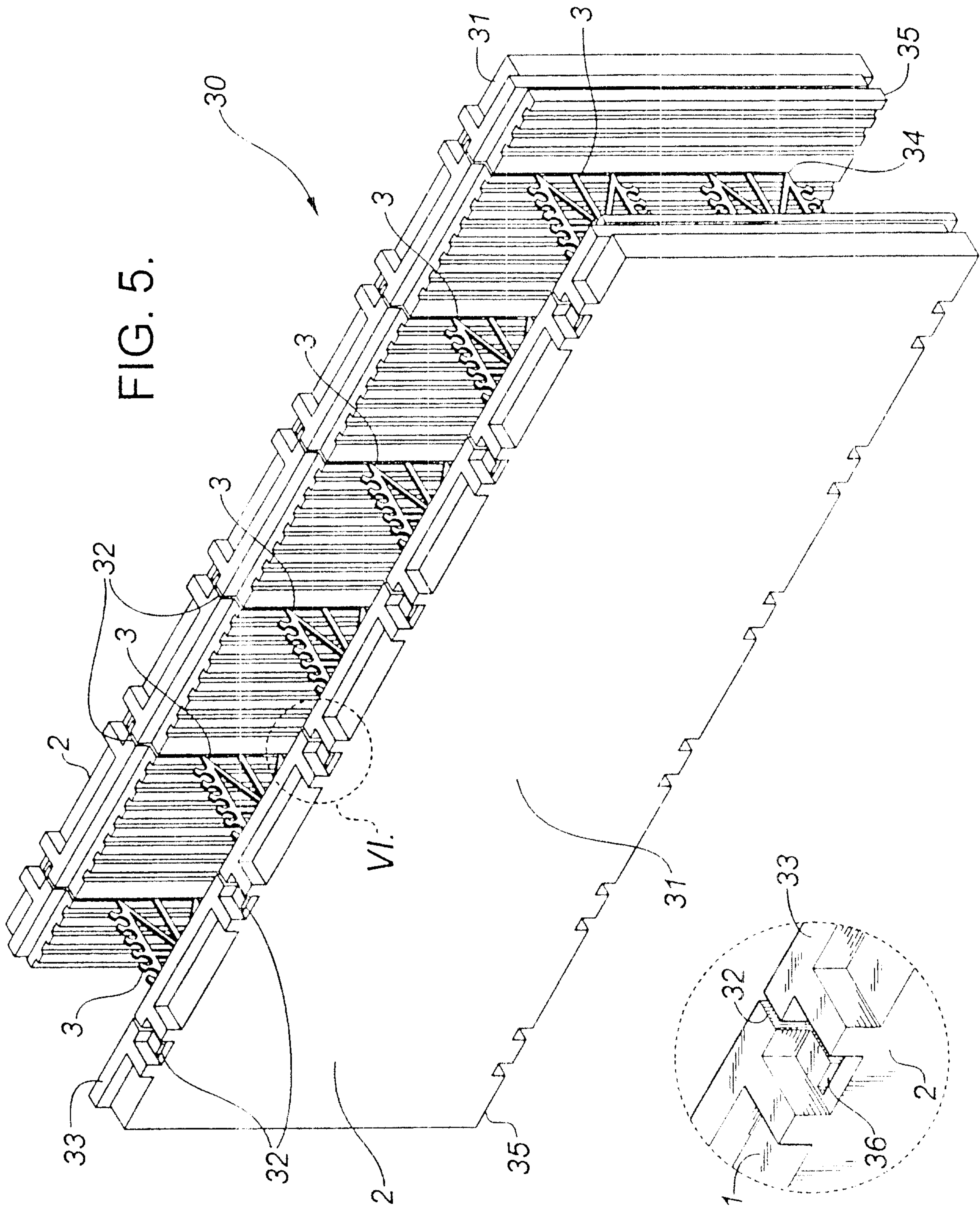

FIG. 5.

FIG. 6.

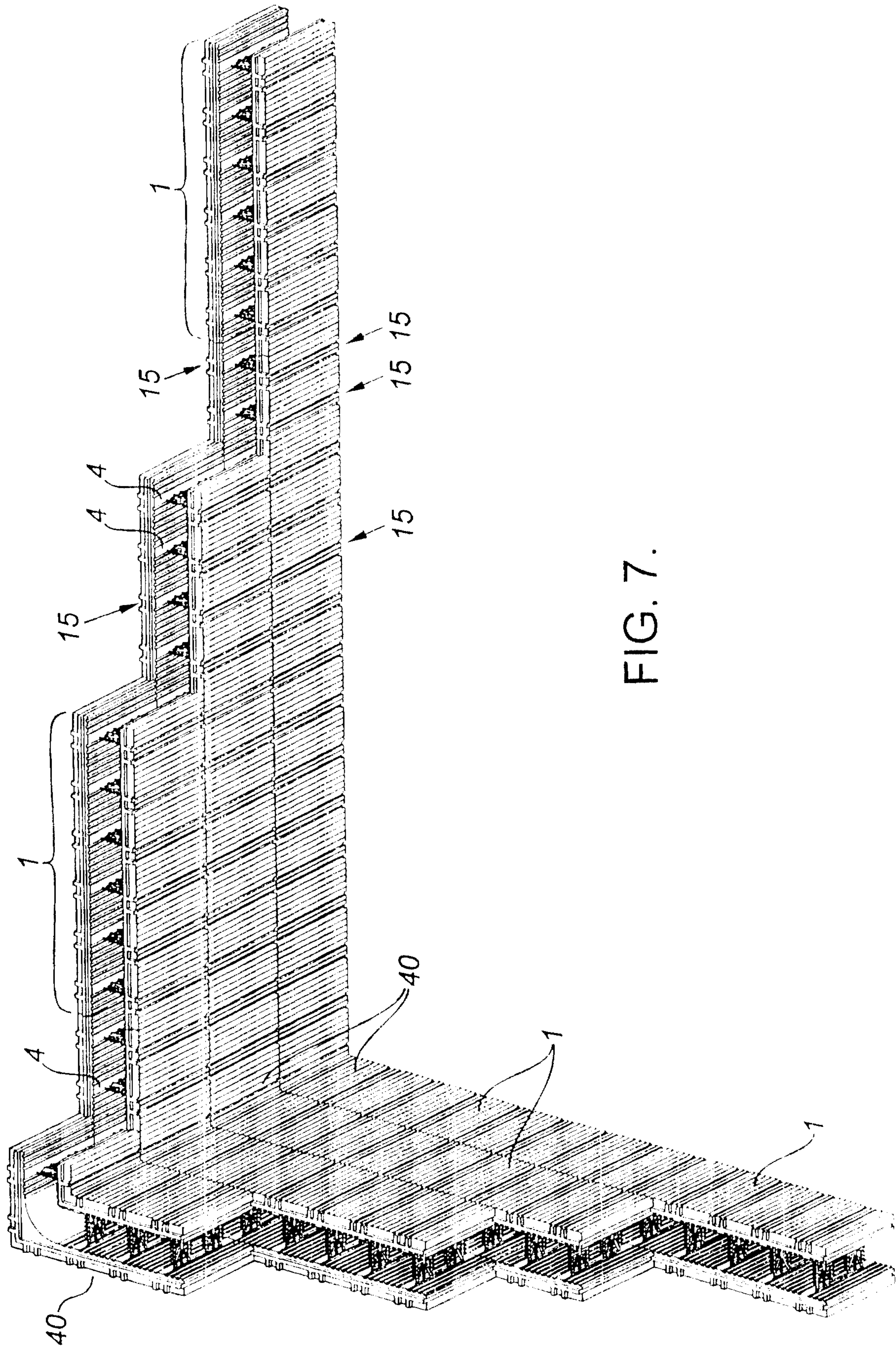

FIG. 7.

