

No. 733,773.

PATENTED JULY 14, 1903.

R. R. & J. H. VOGAN.
ROTARY ENGINE.

APPLICATION FILED FEB. 25, 1903.

NO MODEL.

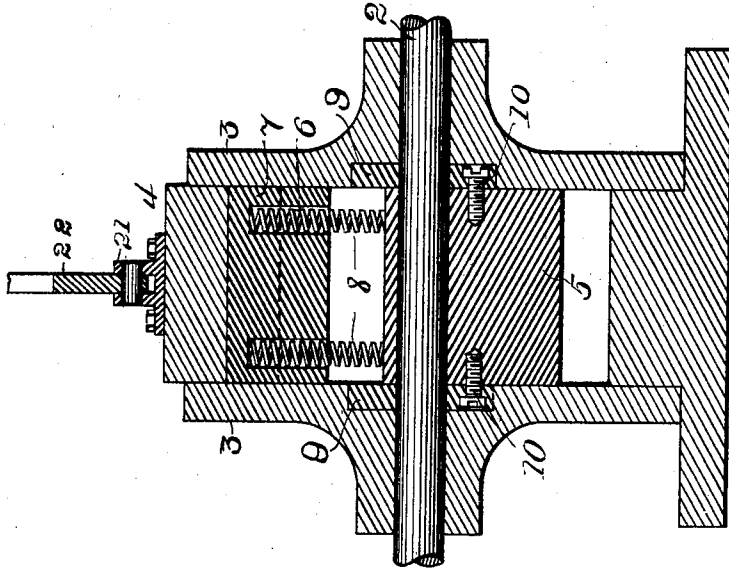

Fig. 2.

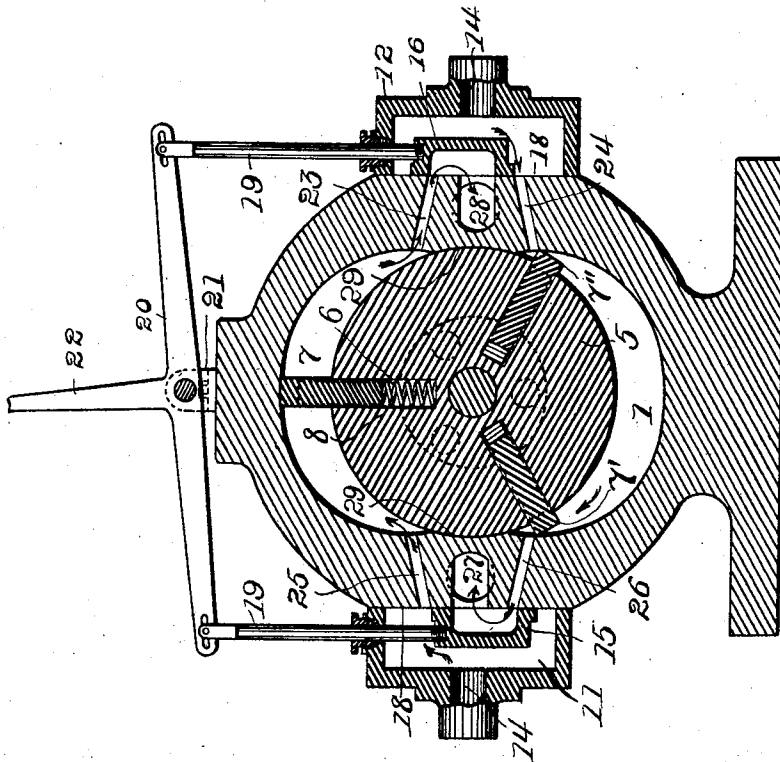

Fig. 1.

WITNESSES

Geo. B. Rowley
C. E. Potter

INVENTORS

R. R. Vogan,
J. H. Vogan,
My. H. C. Everett
Attys

UNITED STATES PATENT OFFICE.

ROBERT R. VOGAN AND JOHN H. VOGAN, OF ALLEGHENY, PENNSYLVANIA.

ROTARY ENGINE.

SPECIFICATION forming part of Letters Patent No. 733,773, dated July 14, 1903.

Application filed February 25, 1903. Serial No. 144,980. (No model.)

To all whom it may concern:

Be it known that we, ROBERT R. VOGAN and JOHN H. VOGAN, citizens of the United States of America, residing at Allegheny, in the county of Allegheny and State of Pennsylvania, have invented certain new and useful Improvements in Rotary Engines, of which the following is a specification, reference being had therein to the accompanying drawings.

This invention relates to certain new and useful improvements in rotary engines, the object of the invention being to construct a rotary engine and to provide means for the admission of the steam simultaneously at opposite sides of the rotary piston, whereby to obtain a greater efficiency from the device and an engine which may, owing to its construction, be easily and readily reversed.

Briefly described, the invention comprises, in connection with the shell or casing, an ellipsoidal cylinder and a circular rotary piston-head mounted in said cylinder, with vanes or valves mounted in said circular piston-head and operated to be forced outwardly into engagement with the walls of the cylinder by springs mounted back of the vanes or valves. Steam-chests are mounted at opposite sides of the cylinder, with a pair of ports leading from each of these chests into the steam-cylinder. Slide-valves are mounted in these steam-chests and control the admission of the steam and the exhaust thereof from the cylinder.

In describing the invention in detail reference is had to the accompanying drawings, forming a part of this specification, and wherein like numerals of reference indicate like parts throughout both views, in which—

Figure 1 is a central vertical sectional view of our improved engine. Fig. 2 is a transverse vertical sectional view of the same.

In the accompanying drawings, 1 indicates the steam-cylinder, which is substantially ellipsoidal in form.

2 indicates the drive-shaft, which extends through the side plates 3 of the engine shell or casing, these side plates being secured to the annular rim 4 in any desired or suitable manner. Mounted on the drive-shaft within the steam-cylinder 1 is a circular piston-head 5, provided in its periphery with radial re-

cesses 6, in which are mounted vanes or valves 7 7' 7", which are at all times under the tension of springs 8, that are seated in the recesses 6 between the inner ends of the valves 7' and the bottom of the recesses 6. Thus the vanes or valves being normally under the pressure of the spring are always forced outwardly, whereby their outer edges contact with the walls of the cylinder. As the recessing of the piston-head to receive the vanes or valves 7 7' 7" may weaken the piston-head to some extent, we preferably provide strengthening plates or disks 9, countersunk in the inner faces of the side plates 3 and secured to the piston-head by tap-screws 10 or other suitable means. Secured to opposite sides of the engine are steam-cylinders 11 12, respectively, having suitable inlet-ports 14. Slide-valves 15 and 16 are mounted in the steam-chests 11 12 and engage the valve-faces 18, formed on the sides of the cylinder-casting. The slide-valves 15 16 are connected by valve rods or stems 19 with the lever 20, pivoted in a suitable bearing 21, mounted on the top of the engine and having a suitable operating handle or lever 22. The ports 23 24 establish communication between the steam-chests 12 and the steam-cylinder, while ports 25 26 establish communication between the steam-chest 11 and the steam-cylinder. Exhaust-ports 27 28 are provided at opposite sides of the engine. The rotary piston 5 frictionally engages the concave seats 29, formed in the walls of the cylinder 1 directly opposite to each of the steam-chests and between the two ports which are at each side of the cylinder.

In operation we will assume that the engine is running in the direction indicated by the arrows, and when in this position ports 24 25 are the inlet-ports from the steam-chests to the steam-cylinder and the steam is exhausted from the steam-cylinder through ports 23 and 26 and the exhaust-ports 27 28, respectively. Assuming the engine to be in the position shown in Fig. 1 of the drawings, the vane or valve 7 is under the action of the live steam being admitted through port 25, while vane or valve 7' is under the action of the expanding steam and is just about to pass the port 26, which will open communication to the exhaust. At this same time the

vane or valve 7' has passed port 24 and is just beginning to take steam through said port, while the steam which was back of said vane or valve 7'' has been exhausted through 5 port 23 to exhaust-port 28. Thus it is to be noted that at any position of the rotary piston two of the blades or valves are under the action of the steam. To reverse the engine, it is simply necessary to rock the lever 20, 10 which may be done by the handle or lever 22, so as to shift the valve 15, whereby to convert port 25 into an exhaust-port and port 26 to an inlet-port, this operation of the lever 20 shifting valve 16, whereby to make port 15 23 an inlet-port and port 24 an exhaust-port. In order to permit the shifting of the valve by connecting the rods or stems thereof to a common lever, as shown, the ends of the lever 20 may be slotted, as shown in Fig. 1 of 20 the drawings. As the piston-rods and vanes or valves are compressed within the recesses in the piston during the time they are passing the concave seats 29 and as soon as they pass the shoulders at the ends of said seats 25 the springs back of the vanes or valves immediately force the same out into engagement with the valve to the cylinder.

It will be noted that various changes may be made in the details of construction without departing from the general spirit of our 30 invention.

Having fully described our invention, what

we claim as new, and desire to secure by Letters Patent, is—

An engine of the type set forth comprising 35 the combination of a cylinder having side plates secured thereto, and strengthening-plates countersunk into the inner faces of said plates, said cylinder having its inner central portion substantially reduced, the enlarged side walls of the cylinder projecting 40 into the interior at the central portion thereof, a shaft secured in the said side or strengthening plates, a piston-head secured thereto and mounted centrally with respect to the 45 enlarged portion of said cylinder, vanes slidably mounted in said head and adapted to be operated to move inwardly upon contact with the enlarged portions of the cylinder, inlet and outlet ports for said cylinder, steam- 50 chests in communication therewith, vertical slidable valves mounted in said steam-chests and adapted to control the inlet and outlet ports and a single actuating means adapted to operate simultaneously each of said valves 55 to alternately open and close the steam-inlet ports, substantially as described.

In testimony whereof we affix our signatures in the presence of two witnesses.

ROBERT R. VOGAN.
JOHN H. VOGAN.

Witnesses:

A. M. WILSON,
E. E. POTTER.