

April 19, 1938.

E. F. AUNGER

2,114,584

OIL BURNING FURNACE

Filed March 23, 1936

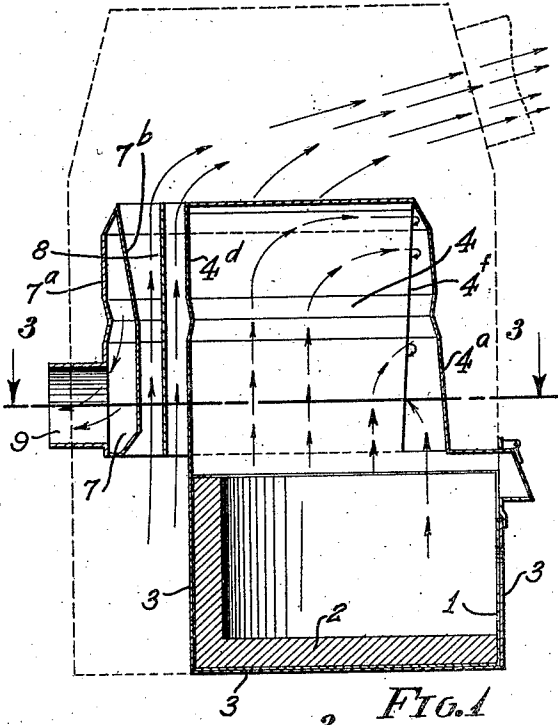

FIG. 1

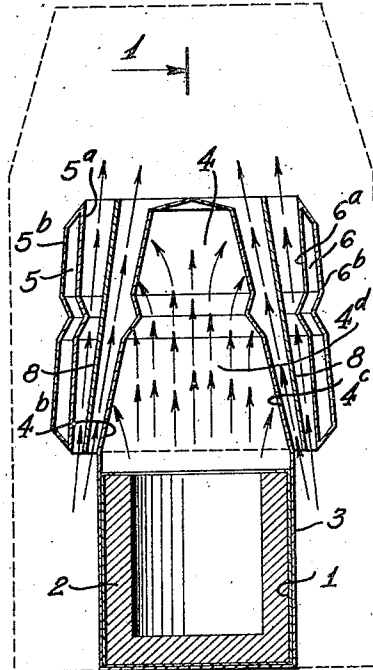

FIG. 2

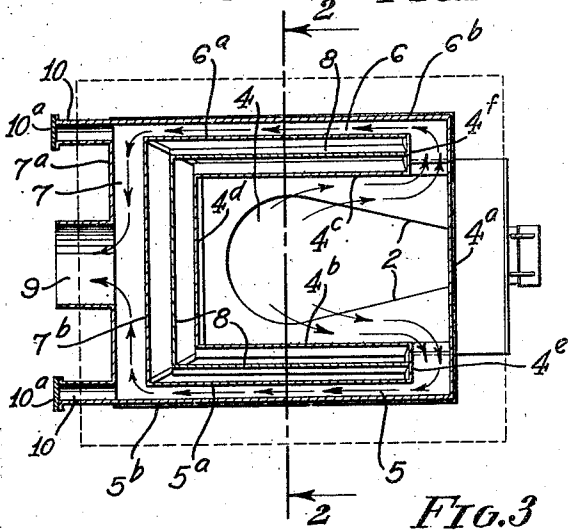

FIG. 3

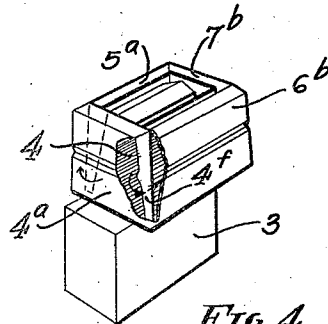

FIG. 4

Inventor

Edwin F. Aunger

A. B. Bowman

Attorney

UNITED STATES PATENT OFFICE

2,114,584

OIL BURNING FURNACE

Edwin F. Auger, Escondido, Calif.

Application March 23, 1936, Serial No. 70,251

8 Claims. (Cl. 126-99)

My invention relates to oil burning furnaces, more particularly a furnace for heating air to be distributed to rooms in the house or building, and the objects of my invention are:

5 First, to provide a furnace which provides a heated metallic surface and in which the air to be heated circulates in close scrubbing relation with the heated surface for heating the air by conduction so as to provide great efficiency;

10 Second, to provide a furnace of this class in which the heat is conducted through narrow channels and the air to be heated circulates through narrow channels in close scrubbing relation with the wall thereof so that the air to be heated is readily heated by conduction through the wall of the heat compartment;

15 Third, to provide a furnace of this class in which there is a metallic partition positioned between two main heating walls which is adapted to take up the heat from the heated walls and by conduction heat the air passing adjacent thereto;

20 Fourth, to provide a furnace of this class in which the distribution of the heat and air to be heated is so arranged for circulation of both the heat and air to be heated that a maximum efficiency is provided in the distribution of the heat and air;

25 Fifth, to provide a furnace of this class in which the heat is conducted upwardly from the fire box into a converging walled chamber, then forwardly, then outwardly, then backwardly in spaced relation to provide large heat conducting surface;

30 Sixth, to provide a furnace of this class which provides a maximum of metallic heat conducting surface in proportion to the size of the furnace;

35 Seventh, to provide a furnace of this class which is very simple and economical of construction, efficient in its action, durable, and which will not readily deteriorate or get out of order.

40 With these and other objects in view as will appear hereinafter, my invention consists of certain novel features of construction, combination, and arrangement of parts and portions as will be hereinafter described in detail and particularly set forth in the appended claims, reference being had to the accompanying drawing and to the characters of reference thereon which form a part of this application in which:

45 Fig. 1 is a sectional view from the line 1-1 of Fig. 2 showing the outline of the outer casing of the furnace by dotted lines; Fig. 2 is a sectional view from the line 2-2 of Fig. 3 showing the outline of the outer casing of the furnace by

dotted lines; Fig. 3 is a sectional view from the line 3-3 of Fig. 1 showing the outline of the outer casing of the furnace by dotted lines and Fig. 4 is a perspective view on a reduced scale of the furnace complete showing portions broken away to facilitate the illustration.

5 Similar characters of reference refer to similar parts and portions throughout the several views of the drawing;

The fire box casing 1, refractory casing 2, main casing 3, main heat collecting and distributing chamber 4, outer heat conducting chambers 5, 6, and 7, partition 8, flue connection 9, and clean-out tubes 10 constitute the principal parts and portions of my furnace.

15 The casing 1 is preferably a metallic casing which may be readily removed from the main casing 3 at its lower side. Mounted in this casing 1 is a refractory casing 2 which is preferably made of fire clay, and in this casing 2 any suitable oil burning apparatus may be used for heating the air. It is preferred to shape the refractory casing 2 so that the walls diverge backwardly as shown best in Fig. 3 of the drawing. The wall of the outer casing 3 which encloses the casing 1 extends upwardly. The front wall 4a and the two side walls 4b and 4c converge upwardly to near the top where the side walls 4b and 4c extend inwardly to a central point at the top of the furnace as shown best in Figs. 1 and 2 of the drawing. These walls 4a, 4b, and 4c are each provided with corrugations intermediate their lower and upper sides adapted to permit ready expansion and contraction of the heated metal without otherwise distorting the same. The back wall 4d of the chamber 4 is preferably straight and it is also provided with a corrugation to permit expansion and contraction without other distortion. The walls 4b and 4c extend forwardly and connect with front walls 4e and 4f which extend outwardly in spaced relation to the front wall 4a as shown best in Figs. 1 and 3 of the drawing. These front walls 4e and 4f diverge from the vertical downwardly providing a downwardly diverging walled space between the walls 4e and 4f and the front wall 4a as shown best in Fig. 1 of the drawing. Connecting with the outer edges of the walls 4e and 4f are backwardly extending metallic walls 5a and 6a which extend backwardly and inwardly inclined from the vertical as shown best in Fig. 2 of the drawing, and each of these walls is provided with a corrugation to permit expansion and contraction without other distortion. Spaced from these walls 5a and 6a and substantially parallel there-

with are the outer walls 5b and 6b which extend backwardly providing heat conducting chambers 5 and 6. The walls 5b and 6b connect at their front ends with the front wall 4a providing a continuous outer wall, the walls 5b and 6b connect at the back side with a wall 7a, which is an outer wall extended across the back side and in which is mounted near the lower side the flue connection 9 and the walls 5a and 6a connect at their back side with a back wall 7b which is spaced inwardly from the wall 7a forming a heat conducting chamber 7 which communicates with the flue connection 9.

Between the walls 4b and 5a and 4c and 6a are formed upwardly diverging walled air conducting chambers for permitting expansion of the air without undue velocity and between the back walls 4d and the walls 7b is provided the partition 8 which bisects said air conducting chamber forming two air conducting chambers on the sides and back of the main heat collecting and distributing chamber 4. Mounted on the back side in the partition 7a and in alignment with the conducting chambers 5 and 6 are clean-out tubes 10 which extend outwardly through the main wall of the furnace, shown by section lines, and which are provided with covers 10a. These tubes are for the purpose of inserting brushes or other means for cleaning the conducting chambers 5 and 6.

The operation of my furnace is as follows: A suitable burner is lighted in the chamber formed by the refractory casing 2 and the heat rises therefrom as shown by the arrows upwardly into the main heat collecting and distributing chamber 4. From thence it moves forwardly around the end walls 4e and 4f; then backwardly through the outer heat conducting chambers 5 and 6; then through the heat conductor chamber 7 and outwardly through connection 9, heating in such circulation the walls 4b and 4c, 5a and 6a, 5b and 6b, and the partition 8; and the air passes upwardly on opposite sides of this partition 8 scrubbing the walls of the partition 8, the outer surface of the walls 4b and 4c, and the inner surface of the walls 5a and 6a and the outer surface of the wall 4d and the inner surface of the wall 7b and taking the heat by conduction from said walls in its passage upwardly. From thence it is distributed in the conventional manner.

Though I have shown and described a particular construction, combination, and arrangement of parts and portions, I do not wish to be limited to this particular construction, combination, and arrangement, but desire to include in the scope of my invention the construction, combination and arrangement substantially as set forth in the appended claims.

Having thus described my invention, what I claim as new and desire to secure by Letters Patent is:

1. In an oil burning furnace, a fire box, a main heat collecting and distributing chamber with upwardly converging side walls communicating with the upper portion of said fire box, outwardly extending upwardly converging heat conducting chambers communicating therewith from bottom to top at the forward side of said heat collecting and distributing chamber, and backwardly extending heat conducting chambers communicating with said outwardly extending heat conducting chambers from bottom to top and spaced from the walls of said main heat conducting and distributing chamber forming

upwardly directed and upwardly enlarging air conducting passages therebetween.

2. In an oil burning furnace, a fire box, a main heat collecting and distributing chamber with upwardly converging side walls communicating with the upper portion of said fire box, outwardly extending upwardly converging heat conducting chambers communicating therewith from bottom to top at the forward side of said heat collecting and distributing chamber, backwardly extending heat conducting chambers communicating with said outwardly extending heat conducting chambers from bottom to top and spaced from the walls of said main heat conducting and distributing chamber forming upwardly directed and upwardly enlarging air conducting passages therebetween, and substantially upright partitions in said air conducting passages at the middle thereof and extending from bottom to top of said air conducting passages.

3. In an oil burning furnace, a fire box, a main heat collecting and distributing chamber with upwardly converging side walls communicating with the upper portion of said fire box, outwardly extending upwardly converging heat conducting chambers communicating therewith from bottom to top at the forward side of said heat collecting and distributing chamber, backwardly extending heat conducting chambers communicating with said outwardly extending heat conducting chambers from bottom to top and spaced from the walls of said main heat conducting and distributing chamber forming upwardly directed and upwardly enlarging air conducting passages therebetween, substantially upright partitions in said air conducting passages at the middle thereof and extending from bottom to top of said air conducting passages, and heat conducting chambers communicating with the back end of said backwardly extending heat conducting chambers spaced from the back wall of said main heat collecting and distributing chamber and forming upwardly directed air conducting passages between said heat conducting chamber and said main heat collecting and distributing chamber wall.

4. In an oil burning furnace, a fire box, a main heat collecting and distributing chamber with upwardly converging side walls communicating with the upper portion of said fire box, outwardly extending upwardly converging heat conducting chambers communicating therewith from bottom to top at the forward side of said heat collecting and distributing chamber, backwardly extending heat conducting chambers communicating with said outwardly extending heat conducting chambers from bottom to top and spaced from the walls of said main heat conducting and distributing chamber forming upwardly directed and upwardly enlarging air conducting passages therebetween, substantially upright partitions in said air conducting passages at the middle thereof and extending from bottom to top of said air conducting passages, heat conducting chambers communicating with the back end of said backwardly extending heat conducting chambers spaced from the back wall of said main heat collecting and distributing chamber and forming upwardly directed air conducting passages between said heat conducting chamber and said main heat collecting and distributing chamber wall, and a flue connection centrally at the back and at the lower side of said back heat conducting chamber.

5. In an oil burning furnace, a fire box, a main

heat collecting and distributing chamber with upwardly converging side walls communicating with the upper portion of said fire box, outwardly extending upwardly converging heat conducting chambers communicating therewith from bottom to top at the forward side of said heat collecting and distributing chamber, backwardly extending heat conducting chambers communicating with said outwardly extending heat conducting chambers from bottom to top and spaced from the walls of said main heat conducting and distributing chamber forming upwardly directed and upwardly enlarging air conducting passages therebetween, substantially upright partitions in said air conducting passages at the middle thereof and extending from bottom to top of said air conducting passages, heat conducting chambers communicating with the back end of said backwardly extending heat conducting chambers spaced from the back wall of said main heat collecting and distributing chamber and forming upwardly directed air conducting passages between said heat conducting chamber and said main heat collecting and distributing chamber wall, a flue connection centrally at the back and at the lower side of said back heat conducting chamber, and a substantially upright partition between said heat conducting chamber and said main heat collecting and distributing chamber forming upwardly directed air conducting passages on each side of said partition at the back side of said main heat collecting and distributing chamber.

6. In an oil burning furnace, a fire box, a main heat collecting and distributing chamber with upwardly converging side walls communicating with the upper portion of said fire box, outwardly extending upwardly converging heat conducting chambers communicating therewith from bottom to top at the forward side of said main heat collecting and distributing chamber, backwardly extending heat conducting chambers communicating with said outwardly extending heat conducting chambers from bottom to top and spaced from the walls of said main heat conducting and distributing chamber, and a back heat conducting chamber connecting the back ends of said backwardly extending heat conducting chambers from bottom to top forming upwardly directed air conducting passages at the sides and back of said

main heat collecting and distributing chamber.

7. In an oil burning furnace, a fire box, a main heat collecting and distributing chamber with upwardly converging side walls communicating with the upper portion of said fire box, outwardly extending upwardly converging heat conducting chambers communicating therewith from bottom to top at the forward side of said main heat collecting and distributing chamber, backwardly extending heat conducting chambers communicating with said outwardly extending heat conducting chambers from bottom to top and spaced from the walls of said main heat conducting and distributing chamber, a back heat conducting chamber connecting the back ends of said backwardly extending heat conducting chambers from bottom to top forming upwardly directed air conducting passages at the sides and back of said main heat collecting and distributing chamber, and a flue positioned at the middle near the lower side of said back heat conducting chamber.

8. In an oil furnace, a fire box, a main heat collecting and distributing chamber with upwardly converging side walls communicating with the upper portion of said fire box, outwardly extending upwardly converging heat conducting chambers communicating therewith from bottom to top at the forward side of said main heat collecting and distributing chamber, backwardly extending heat conducting chambers communicating with said outwardly extending heat conducting chambers from bottom to top and spaced from the walls of said main heat conducting and distributing chamber, a back heat conducting chamber connecting the back ends of said backwardly extending heat conducting chambers from bottom to top forming upwardly directed air conducting passages at the sides and back of said main heat collecting and distributing chamber, a flue positioned at the middle near the lower side of said back heat conducting chamber, and a substantially vertical partition extending from top to bottom in the space between said main heat collecting and distributing chamber wall and said backwardly extending heat conducting chambers and said back heat conducting chamber forming upwardly directed air conducting passages on opposite sides of said partition.

EDWIN F. AUNGER.