

(19) World Intellectual Property
Organization
International Bureau



(43) International Publication Date
2 December 2004 (02.12.2004)

PCT

(10) International Publication Number
WO 2004/105118 A1

- (51) International Patent Classification⁷: **H01L 21/56**
- (21) International Application Number:
PCT/US2004/012019
- (22) International Filing Date: 16 April 2004 (16.04.2004)
- (25) Filing Language: English
- (26) Publication Language: English
- (30) Priority Data:
10/438,526 14 May 2003 (14.05.2003) US
- (71) Applicant: **INTEL CORPORATION** (a Delaware Corporation) [US/US]; 2200 Mission College Boulevard, Santa Clara, CA 95052 (US).
- (72) Inventor: **WATSON, Jeffrey**; 1102 East Thunderhill Place, Phoenix, AZ 85048 (US).
- (74) Agents: **MALLIE, Michael, J.** et al.; Blakely Sokoloff Taylor & Zafman, 12400 Wilshire Boulevard, Los Angeles, CA 90025 (US).
- (81) Designated States (unless otherwise indicated, for every kind of national protection available): AE, AG, AL, AM, AT, AU, AZ, BA, BB, BG, BR, BW, BY, BZ, CA, CH, CN, CO, CR, CU, CZ, DE, DK, DM, DZ, EC, EE, EG, ES, FI, GB, GD, GE, GH, GM, HR, HU, ID, IL, IN, IS, JP, KE, KG, KP, KR, KZ, LC, LK, LR, LS, LT, LU, LV, MA, MD, MG, MK, MN, MW, MX, MZ, NA, NI, NO, NZ, OM, PG, PH, PL, PT, RO, RU, SC, SD, SE, SG, SK, SL, SY, TJ, TM, TN, TR, TT, TZ, UA, UG, US, UZ, VC, VN, YU, ZA, ZM, ZW.
- (84) Designated States (unless otherwise indicated, for every kind of regional protection available): ARIPO (BW, GH, GM, KE, LS, MW, MZ, SD, SL, SZ, TZ, UG, ZM, ZW), Eurasian (AM, AZ, BY, KG, KZ, MD, RU, TJ, TM), European (AT, BE, BG, CH, CY, CZ, DE, DK, EE, ES, FI, FR, GB, GR, HU, IE, IT, LU, MC, NL, PL, PT, RO, SE, SI, SK, TR), OAPI (BF, BJ, CF, CG, CI, CM, GA, GN, GQ, GW, ML, MR, NE, SN, TD, TG).
- Published:**
— with international search report
- For two-letter codes and other abbreviations, refer to the "Guidance Notes on Codes and Abbreviations" appearing at the beginning of each regular issue of the PCT Gazette.

(54) Title: STENCIL AND METHOD FOR DEPOSITING MATERIAL ONTO A SUBSTRATE

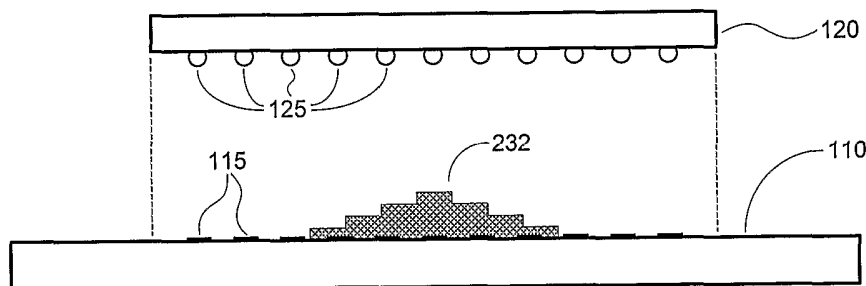

(57) Abstract: A stencil and method for depositing a coupon of underfill material onto a substrate that is to receive an integrated circuit die.

WO 2004/105118 A1

STENCIL AND METHOD FOR DEPOSITING MATERIAL ONTO A SUBSTRATE

FIELD OF THE INVENTION

[0001] The invention relates generally to the packaging of integrated circuit devices
5 and, more particularly, to a stencil and a method for depositing a quantity of underfill
material onto a substrate that is to receive an integrated circuit die.

BACKGROUND OF THE INVENTION

[0002] To package an integrated circuit (IC) chip or die, such as a processing device or
10 a memory device, the IC die is typically mounted on a substrate, this substrate often
referred to as the “package substrate.” The package substrate includes a plurality of leads
that are electrically coupled with the leads of the IC chip, as well as circuitry to route
signals to and from the die. For a flip-chip package – employing, for example, Controlled
Collapse Chip Connect (or “C4”) assembly techniques – an array of bond pads on the IC
15 die are coupled to a corresponding array of leads, or “lands”, on the package substrate by
an array of connection elements (e.g., solder balls, column, etc.). Alternatively, the IC
chip bond pads may be connected to the leads on the package substrate using wirebonding
or another suitable process.

[0003] The circuitry provided by the package substrate routes the IC chip leads to
20 locations on the package substrate where electrical connections can be established with a
next-level component (e.g., a motherboard, a computer system, a circuit board, another IC
device, etc.). For example, the substrate circuitry may route all signal lines to a ball-grid
array – or, alternatively, a pin-grid array – formed on a lower surface of the package
substrate. The ball- or pin-grid array then electrically couples the packaged IC die to the
25 next-level component, which includes a mating array of terminals (e.g., lands, pin sockets,

etc.). Alternatively, the circuitry may route the signal lines to locations proximate the periphery of the package substrate, wherein wirebonding may be used to couple the packaged IC chip to the next-level component.

[0004] The IC die is typically attached to the package substrate using an epoxy or
5 other suitable adhesive. This epoxy forms an “underfill” layer that both attaches the die to the package substrate and provides mechanical support for the die and the electrical connections (e.g., solder elements) between the IC die bond pads and the substrate’s leads. To minimize voids in the underfill layer, the adhesive (or “underfill material”) is typically deposited on the package substrate in a glob or mound, wherein this glob is dispensed onto
10 the package substrate at a location where the die will be attached. When the die is compressed against the package substrate, the underfill material flows outwardly toward the periphery of the die, such that the underfill material forms a substantially void-free and uniformly thick layer underlying the entire lower surface of the die (or a substantial portion thereof).

[0005] An example of the attachment of an IC chip to a package substrate using an underfill material is illustrated in FIGS. 1A through 1C. Referring to FIG. 1A, a package substrate 110 includes a number of leads or lands 115, the lands 115 being arranged in an array. A nozzle 105 or other dispenser (e.g., syringe, dropper, etc.) has dispensed a glob 132 of underfill material (e.g., epoxy) onto an upper surface of the package substrate 110.
20 As shown in FIG. 1B, an IC die 120 has been positioned over the substrate 110. The IC die 120 includes a plurality of connection elements 125, wherein each connection element 125 (e.g., a solder ball, column, etc.) is connected with a bond pad (not shown in figures) on the IC die 120. The connection elements 125 on IC die 120 are arranged in an array corresponding to the arrangement of the lands 115 on the package substrate 110.

[0006] Referring now to FIG. 1C, the IC die 120 has been joined with the package substrate 110 to form an IC package 100. The die 120 has been compressed against the substrate 110, and the underfill material 132 has been forced to flow outwardly from the interior of the die 120 toward the periphery thereof to form an underfill layer 130. By
5 placing the underfill material 132 near the center of the substrate (or near the center of the array of lands 115) and forcing this material to flow outwardly under the force of compressing the die 120 against the substrate 110, voids in the underfill layer 130 are minimized and a substantially uniform underfill layer 130 is formed. Solder reflow may then take place to electrically connect each connection element 125 to its mating lead 115
10 on the package substrate 110 and, if necessary, any post-curing of the underfill layer 130 may be performed. As noted above, the underfill layer 130 attaches the die 120 to the package substrate 110 and also provides mechanical support for the substrate-to-die electrical connections (e.g., leads 115, connection elements 125, and the die bond pads).

[0007] Time-pressure type dispensing systems, such as the nozzle 105 shown in FIG.
15 1A, have proven adequate with respect to deposition of the underfill material at the correct location and in a desired shape (i.e., a shape having a height that is greater than the thickness of the final underfill layer, such that the underfill material flows outwardly under compression of the die against the substrate). However, these time-pressure dispensers are relatively slow, and their use can negatively impact the pace of a production line.

20

BRIEF DESCRIPTION OF THE DRAWINGS

[0008] FIGS. 1A through 1C are schematic diagrams illustrating a conventional method of dispensing underfill material between a substrate and an IC device;

[0009] FIGS. 2A through 2C are schematic diagrams illustrating an embodiment of a method of depositing underfill material onto a substrate using a stencil, as disclosed herein.

[0010] FIG. 3A is a perspective view of one embodiment of a stencil for depositing a
5 quantity of material onto a substrate.

[0011] FIG. 3B is a plan view of the stencil illustrated in FIG. 3A.

[0012] FIG. 3C is a side elevation view of the stencil illustrated in FIG. 3A.

[0013] FIG. 3D is a perspective view of a stepped coupon that may be created using the stencil of FIGS. 3A-3C.

10 [0014] FIGS. 3E-3H each illustrate an alternative embodiment of the stencil of FIGS. 3A-3C.

[0015] FIGS. 4A-4D are schematic diagrams illustrating an embodiment of a method of depositing a stepped coupon of underfill material on a substrate using the disclosed stencil.

15 [0016] FIG. 5 is a block diagram illustrating an embodiment of a method of depositing a coupon of underfill material onto a substrate using the disclosed stencil.

[0017] FIG. 6A is a plan view of a carrier holding a plurality of substrates.

[0018] FIG. 6B is a plan view of an embodiment of a stencil having a number of apertures, the stencil disposed over the carrier of FIG. 6A.

20 [0019] FIG. 6C is a side elevation view of the three-dimensional stencil and carrier of FIGS. 6A and 6B, respectively.

DETAILED DESCRIPTION OF THE INVENTION

[0020] Illustrated in FIGS. 2A-2C is an embodiment of the attachment of an IC die to
25 a package substrate with underfill material that has been deposited on the package

substrate using a stencil, as disclosed herein. The disclosed embodiments of the stencil provide an efficient mechanism for depositing a quantity of underfill material onto the substrate, wherein the shape of the deposited material is determined by the stencil design. Embodiments of a stencil and method of depositing material onto a substrate are described
5 herein in the context of attaching an IC die to a package substrate (e.g., the flip-chip attachment of a die to a package substrate using C4 assembly techniques). However, it should be understood that the disclosed embodiments are not so limited in application and, further, that the disclosed stencils and methods may find use in any application where the dispensing of a quantity of material in a desired shape is needed (e.g., attaching a
10 packaged IC device to a next-level component, such as a circuit board).

[0021] Referring to FIG. 2A, a substrate 110 (e.g., a package substrate) includes a number of leads or lands 115, the lands 115 being arranged in an array. A quantity of underfill material 232 has been deposited on the substrate 110 using a stencil, which will be described in detail below. The underfill material 232 has been deposited in a pyramidal
15 or “stepped” shape, and this stepped block, or “coupon,” of material has a center height that is greater than its peripheral height and that is greater than a height of the final, compressed layer of underfill material between the substrate and a die. Thus, when the stepped coupon of underfill material 232 is compressed between a die and the substrate, the underfill material 232 will flow outwardly underneath the die to form a substantially
20 void-free underfill layer.

[0022] As shown in FIG. 2B, an IC die 120 has been positioned over the substrate 110. The IC die 120 includes a plurality of connection elements 125, wherein each connection element 125 (e.g., a solder ball, column, etc.) is connected with a corresponding bond pad (not shown in figures) on the die 120. The connection elements 125 are arranged in an
25 array corresponding to the arrangement of the lands 115 on substrate 110. In one

embodiment, the die 120 comprises a flip-chip die that is to be attached to the substrate 110 using C4 assembly techniques.

[0023] Turning to FIG. 2C, the IC die 120 has been joined with the substrate 110 to form a packaged IC device 200. The die 120 has been compressed against the substrate 5 110, and the underfill material 232 has been forced to flow outwardly from the interior of the die 120 toward the periphery thereof to form an underfill layer 230. The underfill layer 230 attaches the die 120 to the substrate 110 and also provides mechanical support for the substrate-to-die electrical connections (e.g., leads 115, connection elements 125, and the die bond pads). Solder reflow may then be performed to electrically connect each 10 connection element 125 to its mating lead 115 on the substrate 110. Also, if necessary, a post-cure of the underfill layer 230 may be performed.

[0024] Referring now to FIGS. 3A through 3C, illustrated is an embodiment of a stencil 300 that may be used to create the stepped coupon of material 232 shown in FIGS. 2A and 2B. With reference to FIGS. 3A, 3B, and 3C, the stencil 300 comprises a plate 15 310 having an upper surface 311 and an opposing lower surface 312. The plate 310 can have any suitable thickness 317 and, in one embodiment, the plate's thickness 317 ranges from 0.1 mm to 1 mm.

[0025] Extending through the plate 310 is an aperture 320. The size and shape of the aperture 320 determines the outer dimensions of the coupon that will be formed by the 20 stencil, and the aperture's size and shape is generally matched to the size of a die (or range of die sizes) for which the stencil is designed. In one embodiment, the aperture 320 is generally rectangular in shape or square in shape; however, the aperture 320 may have any suitable shape (e.g., circular). The aperture 320 may have any suitable size depending on the die for which the stencil 300 is designed for. In one embodiment, the aperture 320

comprises a square shape (or, more generally, a rectangular shape) whose edges range between 3 mm and 25 mm in length.

[0026] Extending upwardly from the upper surface 311 of plate 310 is one or more raised features, including raised features 330a, 330b. In one embodiment, as shown in FIGS. 3A-3C, each of the raised features 330a, 330b comprises a series of steps, including steps 341a, 342a, 343, 342b, 341b. Any suitable height and number of steps may be employed, depending on the desired shape of the coupon that is to be formed with the stencil 300. Also, any suitable number of raised features 330a-b may be employed (e.g., one or more than two).

[0027] The stencil 300, including plate 310 having aperture 320 and raised features 330a-b, may be constructed from any suitable material using any suitable fabrication technique. In one embodiment, the stencil 300 is fabricated using an etching process (e.g., a sequential series of mask and chemical etch steps). In this embodiment, the stencil 300 may be constructed of copper, a copper alloy, stainless steel, or any other material amenable to etching. In another embodiment, the stencil comprises molded plastic or, more generally, is formed from any suitable material using a molding process. In a further embodiment, the stencil 300 is fabricated using an electro-forming process, wherein the stencil comprises a series of layers built up using a metal plating process. Also, in yet another embodiment, the aperture (or apertures) 320 is cut out using a laser.

[0028] Shown in FIG. 3D is an embodiment of a stepped coupon 390 of underfill material, as may be created using the stencil 300 of FIGS. 3A-3C. Generally, the coupon 390 will have a shape that matches the shape and configuration of the aperture 320 and, further, that matches the profile of the raised features 330a, 330b extending upwards from the plate 310. In the embodiment of FIGS. 3A-3D, the stepped coupon 390 has a number of steps, including steps 391a, 392a, 393a, 394, 393b, 392b, 391b, which steps generally

match the series of steps of raised features 330a, 330b. Note that the number of levels (e.g., 4) of steps on the stepped coupon 390 exceeds the number of levels (e.g., 3) of steps in the series of steps of raised features 330a, 330b. This result occurs because the plate 310 itself results in the formation of one level of steps, wherein the upper surface 311 of plate 310 corresponds to the first level of steps on the coupon 390 (i.e., steps 391a, 391b).

[0029] The disclosed embodiments of the stencil are not limited to the stepped shape shown in FIGS. 2A-2C and 3A-3D. The raised features 330a, 330b on stencil 300, as well as the coupon 390 formed by the stencil 300, may be of any suitable shape and/or configuration, as desired. This is illustrated in FIGS. 3E through 3H, each of which illustrates an alternative embodiment of the raised features 330a-b on stencil 300. In general, the profile of the raised features 330a-b can be tailored to provide any desired shape for a block of material to be deposited using the stencil. The embodiments of the stencil 300 shown in each of FIGS. 3E through 3H may be suitable for a stencil created from molded plastic (or other molded material), whereas the embodiment of stencil 300 shown in FIGS. 3A-3C may be suitable for a stencil fabricated using an etching process.

[0030] Illustrated in FIGS. 4A through 4D is a method of depositing a coupon of material using the stencil 300 of FIGS. 3A-3C, and FIG. 5 illustrates a method 500 of depositing a quantity of material using the disclosed stencil. Note that, in each of FIGS. 4A through 4C, the stencil 300 is shown in dashed line. Each of FIGS. 4A-4D and FIG. 5 should be referenced in the following discussion, as called out in the text.

[0031] Referring to block 510 in FIG. 5, a stencil is positioned over a substrate, and underfill material is applied to the stencil, as shown at block 520. Generally, the underfill material is deposited on the stencil's upper surface at a location adjacent the aperture (e.g., in the region 319 shown in dashed line in FIGS. 3A and 3B). This is shown in FIG. 4A, where the stencil 300 (shown in dashed line) has been positioned over a substrate 110, and

underfill material 494 has been disposed on the upper surface 311 of the stencil 300 at a location adjacent the aperture 320. The underfill material 494 may comprise any suitable adhesive or other bonding agent, such as an epoxy. In one embodiment, the underfill material includes a flux or other cleaning agent to assist in solder reflow. In another embodiment, the underfill material includes a filler material (e.g., silica) to alter the mechanical and/or thermal properties of the underfill material. For example, a filler may be added to increase the strength of the underfill material and/or a filler may be added to adjust the thermal properties of the underfill material to match those of the die and/or substrate. The volume of underfill material 494 should at least substantially equal the volume of the coupon of material to be formed and, in one embodiment, the volume of underfill material exceeds the amount of material needed to produce the coupon.

[0032] Returning to FIG. 5, the underfill material is forced into the aperture 320 in the stencil 300, as shown at block 530. The underfill material may be forced to flow into the aperture 320 using any suitable device, such as a squeegee, blade, roller, or similar device. This is illustrated in FIGS. 4A through 4C. Referring to FIG. 4A, a squeegee device 470 is moved over the upper surface 311 of the stencil 300 in a direction toward the aperture 320 (see arrow 473). The underfill material 494 is forced into the aperture 320 as the squeegee 470 travels over the upper surface 311 and the raised features 330a-b of the stencil 300, as shown in FIG. 4B. In FIG. 4C, the squeegee 470 has completed one pass over the aperture 320 and raised features 330a-b of the stencil 300, and the quantity of underfill material forced into the aperture 320 generally conforms to the shape of the aperture 320 and raised features 330a-b. Note that some underfill material 494 may remain on the upper surface 311 of the stencil 300. The squeegee 470 may make additional passes over the aperture 320 and raised features 330a-b, as necessary to fill the space within the aperture 320 and raised features 330a-b. Further, in one embodiment, the

underfill material 494 is pre-heated to improve its flow characteristics prior to being forced into the aperture 320. The pre-heat temperature may range from 80° C to 120° C.

[0033] Turning again to FIG. 5, the stencil may be removed from the substrate, as illustrated at block 540. This is shown in FIG. 4D, where the stencil 300 has been lifted off the substrate 110, leaving a stepped coupon 492 on an upper surface of the substrate 110. It should be understood that, due to the motion of the squeegee 470 (or other device used to cause the underfill material to flow into the aperture 320) as it traverses the profile (e.g., the steps) of the raised features 330a-b, the coupon 490 may not precisely conform to the profile of the raised features 330a-b (e.g., see rounded corners of coupon 492, as shown in FIG. 4D).

[0034] Referring back to FIG. 5, further embodiments of the method 500 are illustrated in each of block 550 through 580. In one embodiment, as shown at block 550, a die is placed over the stepped coupon 492 (see FIG. 2B). In another embodiment, this die is compressed against the substrate (see FIG. 2C), thereby causing the underfill material of the stepped coupon 492 to flow outwardly toward the periphery of the die, as shown at block 560. The compressive force applied between the die and substrate may, in one embodiment, range from 4.9 N to 98.1 N (e.g., as may be obtained by placing a mass over the die of between 0.5 Kg and 10 Kg). In a further embodiment, which is illustrated in block 570, solder reflow is performed to electrically couple bond pads on the substrate with leads on the die (e.g., by reflowing solder elements coupled with the die leads). The underfill material sets up and solidifies around the solder joints; however, the underfill material may achieve a gel state rather than becoming fully cured. Thus, in yet another embodiment, as shown at block 580, the underfill material is cured (e.g., as by heating), if necessary.

[0035] The method described in blocks 510 through 540 of FIG. 5 (as well as the embodiments of blocks 550 through 580) may be repeated for other substrates (and die), and the same stencil 300 may be re-used for multiple substrates. In one embodiment, the stencil 300 is designed for use with a specified die size, and the stencil may be re-used for multiple die-attach operations of the specified die size. In another embodiment, the stencil 300 is designed for use with a range of die sizes, and the stencil 300 may be re-used for multiple die-attach operations of varying die sizes.

[0036] Thus far, a stencil having a single aperture for forming a single coupon has been described. However, the disclosed embodiments are not limited to this case. In another embodiment, a stencil includes multiple apertures and raised features to form a number of coupons. This embodiment is illustrated in FIGS. 6A through 6C.

[0037] Referring to FIG. 6A, a number of substrates 660 (e.g., package substrates) are disposed in a carrier 650 (e.g., a tray, tape, or similar device for holding a plurality of substrates). The substrates 660 are arranged on the carrier 650 in a two-by-four array. A typical carrier may measure 6 inches by 12 inches and hold between 8 and 12 substrates, depending upon their size. However, a carrier may be as small as 2 inches across (e.g., a carrier for a single substrate or a single row of substrates).

[0038] Referring now to FIGS. 6B and 6C, a stencil 600 is positioned over the carrier 650 and the plurality of substrates 660 (note that, in FIG. 6C, the stencil 600 is shown vertically offset from the carrier and substrates for clarity). The stencil 600 comprises a plate 610 having a number of apertures, including apertures 620a through 620h, wherein the apertures are generally arranged in a pattern matching the array of substrates 660 on carrier 650. Located proximate a periphery of the apertures 620a-h and extending upwards from an upper surface 611 of the plate 610 are a number of raised features, including raised features 630a through 630l, as illustrated in FIGS. 6B and 6C. In one

embodiment, each of the raised features 630a-k comprises a series of steps, including steps 641a, 642a, 643, 642b, 641a, as shown in FIG. 6C. The stencil 600 may be fabricated in a manner similar to that described above for the stencil 300 of FIGS. 3A-3C (e.g., by etching a metal or other suitable material, molded plastic, electro-forming, etc.).

[0039] The stencil 600 may be used to deposit a number of coupons of underfill material onto the substrates 660 – i.e., one coupon on each substrate – held in the carrier 650. Formation of the coupons would proceed in a similar manner as that described above with respect to FIGS. 4A-4D and FIG. 5. Underfill material is dispensed onto the upper surface 611 at one end of the plate 610 in a region 619 adjacent some of the apertures (e.g., apertures 620a, 620b). However, as the squeegee (or other similar device) travels over the stencil 600, underfill material is forced into all of the apertures 620a-h. Thus, during one operation, multiple coupons can be deposited onto a number of substrates, thereby providing a much more efficient process for the manufacturing environment. The stencil 600 may also be re-used, as described above.

[0040] Embodiments of stencil 300, 600 for forming a coupon (e.g., a stepped coupon) of material on a substrate, as well as embodiments of a method 500 for forming such a coupon on a substrate, having been herein described, those of ordinary skill in the art will appreciate the advantages of the disclosed embodiments. The disclosed stencil enables the deposition onto a substrate of a coupon having a shape that will provide the flow characteristics desired for the underfill layer in an IC package. Formation of the coupon, or a number of such coupons, is relatively fast and requires few manufacturing steps. The stencils can be fabricated using well-known, low-cost chemical etch processing techniques, and the stencils can be re-used multiple times. Further, the disclosed embodiments can be used with existing stenciling equipment.

[0041] The foregoing detailed description and accompanying drawings are only illustrative and not restrictive. They have been provided primarily for a clear and comprehensive understanding of the disclosed embodiments and no unnecessary limitations are to be understood therefrom. Numerous additions, deletions, and modifications to the embodiments described herein, as well as alternative arrangements, may be devised by those skilled in the art without departing from the spirit of the disclosed embodiments and the scope of the appended claims.

CLAIMS

What is claimed is:

1. An apparatus comprising:
a plate having an upper surface and an opposing lower surface;
an aperture extending through the plate; and
a raised feature located proximate a periphery of the aperture and extending upwards from the upper surface of the plate;
wherein material deposited into the aperture substantially conforms in shape to the aperture and the raised feature.
2. The apparatus of claim 1, wherein the raised feature comprises a number of steps.
3. The apparatus of claim 1, further comprising:
a second raised feature located proximate the periphery of the aperture and extending upwards from the upper surface of the plate.
4. The apparatus of claim 1, wherein the aperture is substantially rectangular in shape.
5. The apparatus of claim 1, wherein the aperture is substantially square in shape.

6. The apparatus of claim 1, wherein the plate comprises a metal or a plastic material.
7. An apparatus comprising:
a plate having an upper surface and an opposing lower surface;
an aperture extending through the plate;
a first raised feature located proximate a periphery of the aperture and extending upwards from the upper surface of the plate; and
a second raised feature located proximate the periphery of the aperture and extending upwards from the upper surface of the plate;
wherein material deposited into the aperture forms a coupon having a shape substantially corresponding to the aperture and the first and second raised features.
8. The apparatus of claim 7, wherein the coupon comprises a stepped coupon.
9. The apparatus of claim 7, wherein each of the first and second raised features comprises a number of steps.
10. The apparatus of claim 7, wherein the plate comprises a metal.
11. The apparatus of claim 10, wherein the plate comprises at least one of a copper material, a copper alloy material, and a stainless steel material.

12. The apparatus of claim 7, wherein the plate, the first raised feature, and the second raised feature comprise a single part.
13. The apparatus of claim 7, wherein the plate comprises a molded plastic.
14. The apparatus of claim 7, wherein the apparatus is formed by an etching process or an electro-forming process.
15. The apparatus of claim 7, wherein the aperture is rectangular in shape.
16. The apparatus of claim 7, wherein the aperture is square in shape.
17. The apparatus of claim 7, further comprising:
a second aperture extending through the plate;
a third raised feature located proximate a periphery of the second aperture and extending upwards from the upper surface of the plate; and
a fourth raised feature located proximate the periphery of the second aperture and extending upwards from the upper surface of the plate;
wherein material deposited into the second aperture forms a coupon having a shape substantially corresponding to the second aperture and the third and fourth raised features.
18. The apparatus of claim 17, wherein the shape of the coupon formed by the second aperture is substantially identical to the shape of the coupon formed by the aperture.

19. The apparatus of claim 17, wherein one of the first and second raised features and one of the third and fourth raised features comprise one raised feature disposed between the second aperture and the aperture.

20. A method comprising:
positioning a stencil over a substrate, the stencil including an aperture extending therethrough and a raised feature located proximate the aperture and extending upwardly from an upper surface of the stencil;
applying a quantity of material on the upper surface of the stencil; and
forcing the material into the aperture with a device by moving the device over the aperture and the raised feature.

21. The method of claim 20, wherein the raised feature comprises a number of steps.

22. The method of claim 20, further comprising removing the stencil, wherein a coupon formed in the aperture remains on the substrate.

23. The method of claim 22, wherein the coupon comprises a stepped coupon.

24. The method of claim 20, further comprising:
positioning an integrated circuit die over the coupon; and
compressing the integrated circuit die against the substrate, wherein the coupon material flows outwardly toward a periphery of the integrated circuit die.

25. The method of claim 24, wherein the integrated circuit die includes an array of bond pads and the substrate includes a corresponding array of lands, each of the bond pads on the die having a solder element attached thereto, the method further comprising heating the substrate and die assembly to reflow the solder elements.
26. The method of claim 25, further comprising curing the material.
27. The method of claim 20, wherein the material comprises an epoxy material.
28. The method of claim 20, wherein the material includes a solder flux.
29. The method of claim 20, wherein the material includes a filler material.
30. The method of claim 29, wherein the filler material comprises a silica material.
31. The method of claim 20, wherein the device comprises a squeegee device.
32. The method of claim 20, further comprising re-using the stencil with other substrates.
33. A method comprising:
positioning a stencil over a carrier holding a number of substrates, the stencil including a corresponding number of apertures extending therethrough and a number of raised features, each raised feature located proximate one of the apertures and extending

upwardly from an upper surface of the stencil, wherein each aperture is aligned with one of the substrates;
applying a quantity of material on the upper surface of the stencil; and
forcing the material into the apertures with a device by moving the device over the apertures and the raised features.

34. The method of claim 33, wherein each of the raised features comprises a number of steps.

35. The method of claim 33, further comprising removing the stencil, wherein a coupon formed in each of the apertures remains on each of the substrates.

36. The method of claim 35, wherein each coupon comprises a stepped coupon.

37. The method of claim 33, further comprising:
positioning a die over each of the coupons; and
compressing each die against the carrier, wherein the coupon material underneath each die flows outwardly toward a periphery of the die.

38. The method of claim 37, wherein each die includes an array of bond pads and each substrate includes a corresponding array of lands, each of the die bond pads having a solder element attached thereto, the method further comprising heating the substrate and die assemblies to reflow the solder elements.

39. The method of claim 38, further comprising curing the material on each substrate and die assembly.
40. The method of claim 33, wherein the material comprises an epoxy material.
41. The method of claim 33, wherein the material includes a solder flux.
42. The method of claim 33, wherein the material includes a filler material.
43. The method of claim 42, wherein the filler material comprises a silica material.
44. The method of claim 33, wherein the device comprises a squeegee device.
45. The method of claim 33, further comprising re-using the stencil for other substrates.

1/7

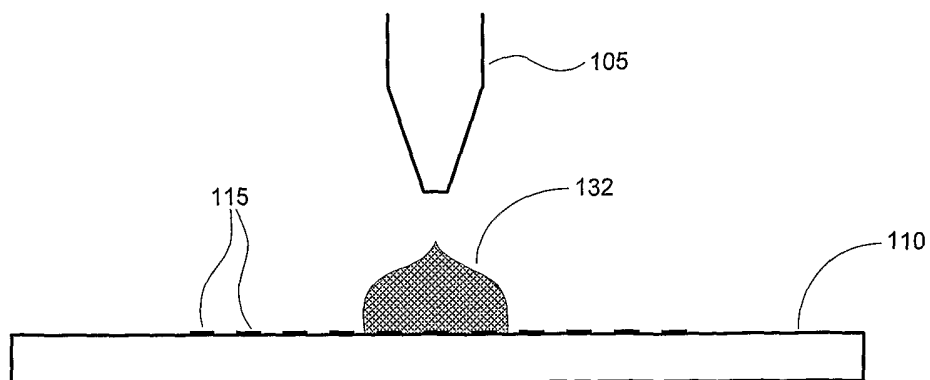

FIG. 1A (PRIOR ART)

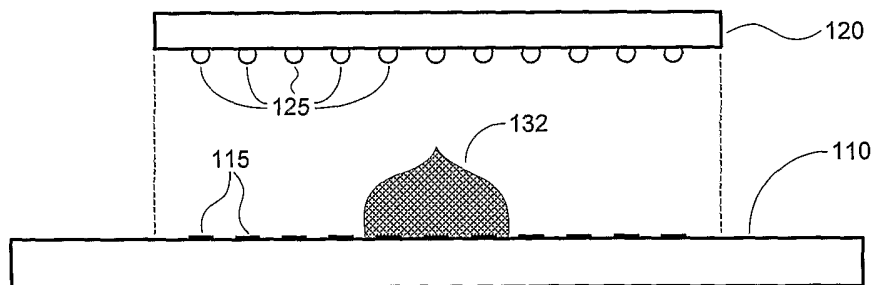

FIG. 1B (PRIOR ART)

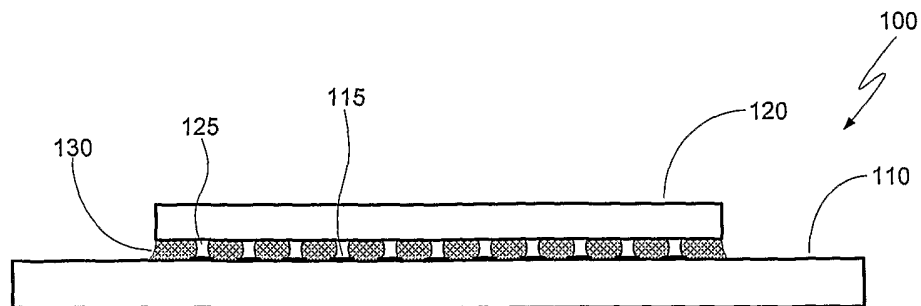

FIG. 1C (PRIOR ART)

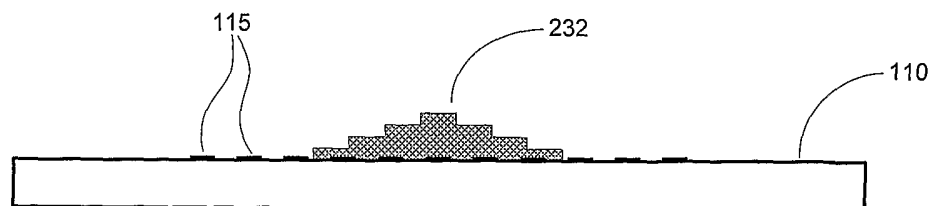

FIG. 2A

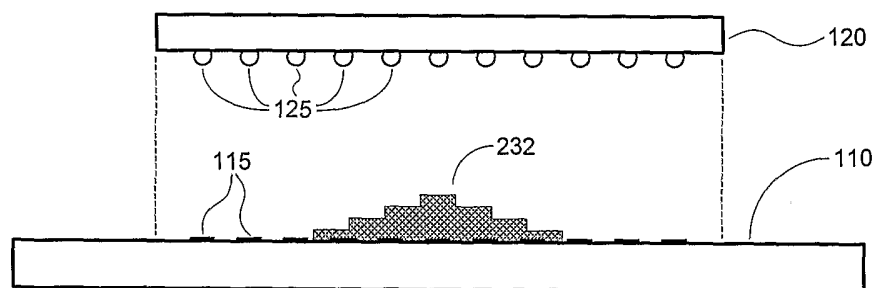

FIG. 2B

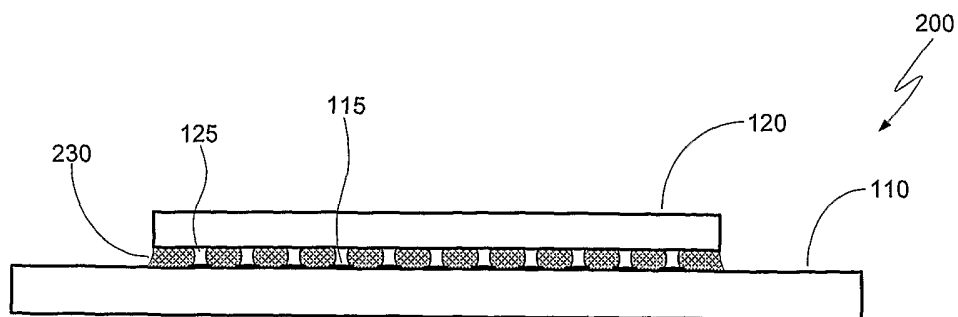

FIG. 2C

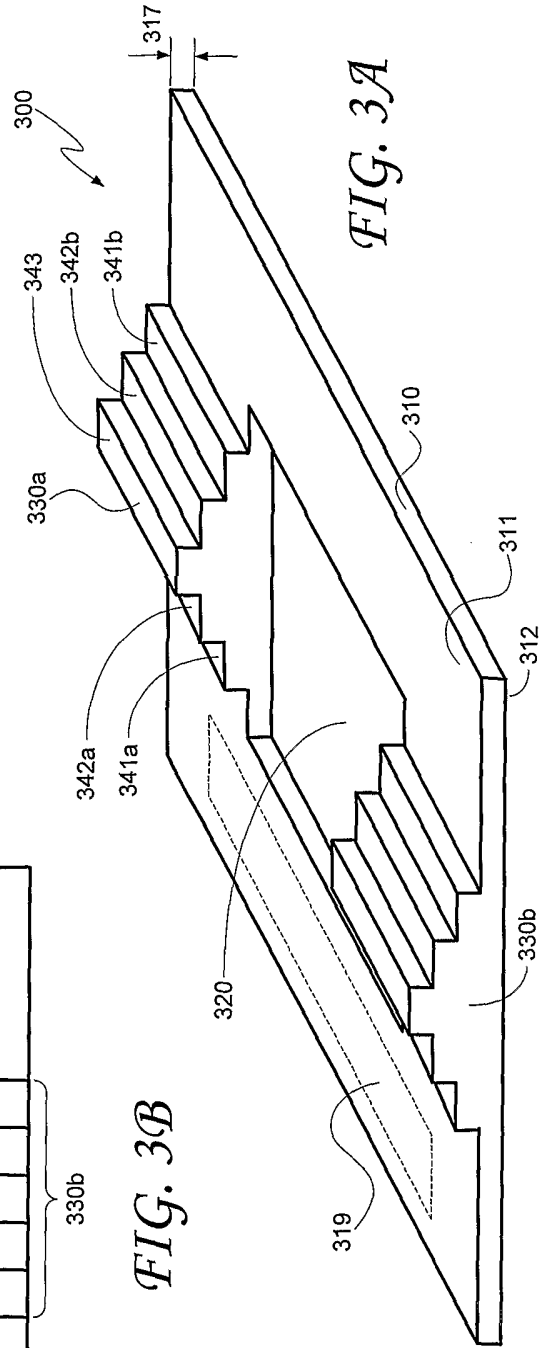
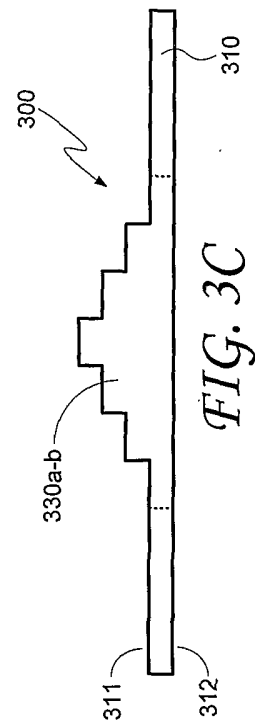
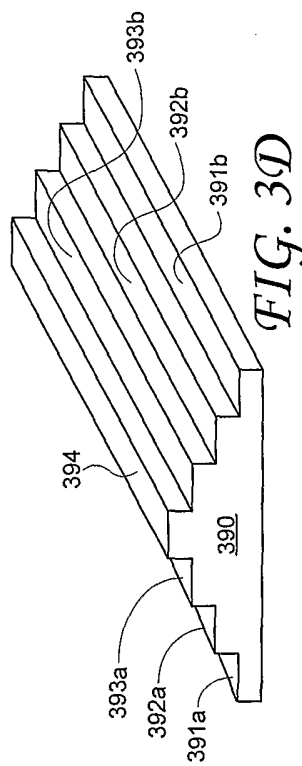
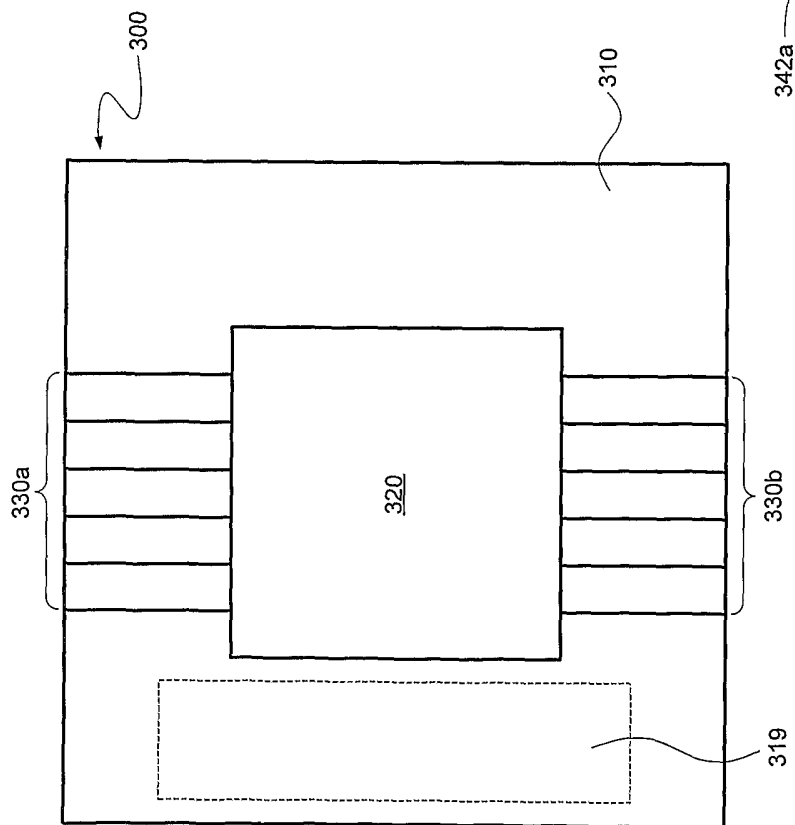

FIG. 3B

FIG. 3A

FIG. 3D

FIG. 3C

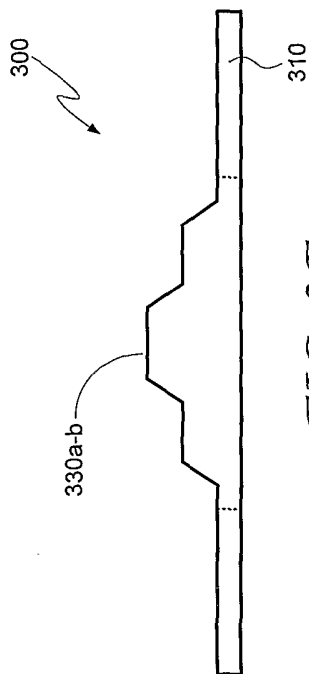

FIG. 3F

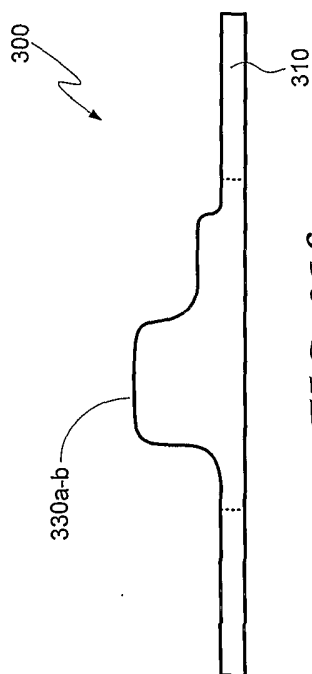

FIG. 3H

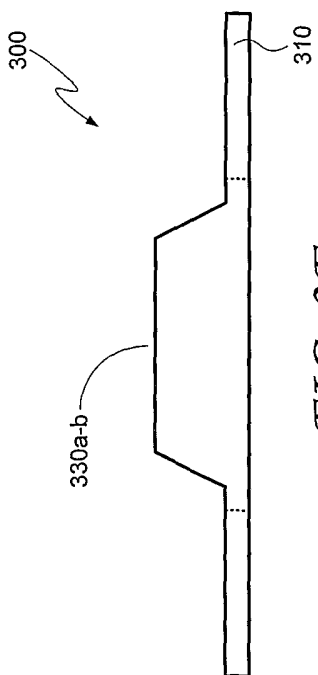

FIG. 3E

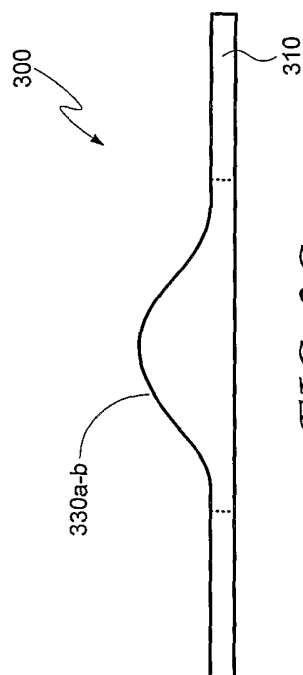

FIG. 3G

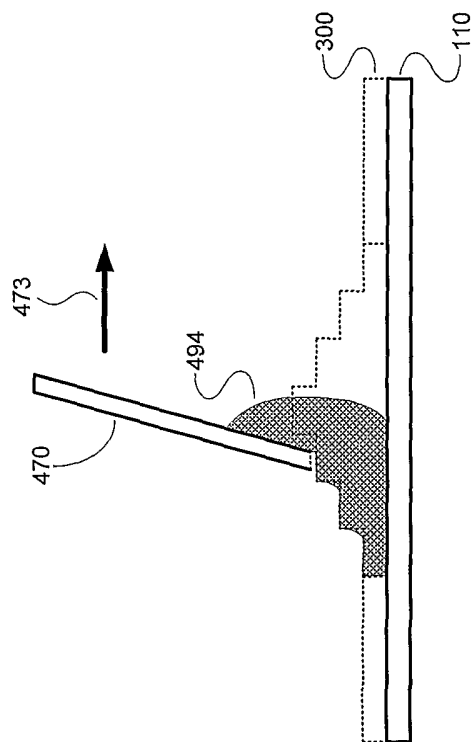

FIG. 4B

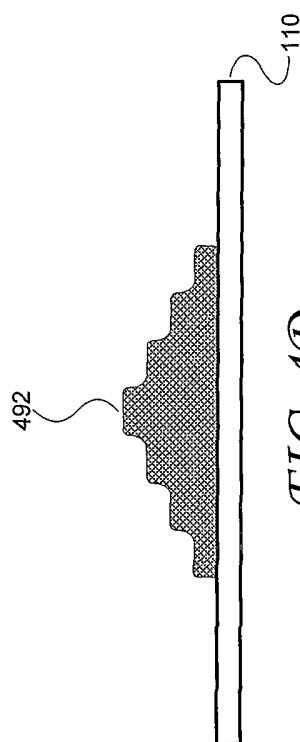

FIG. 4D

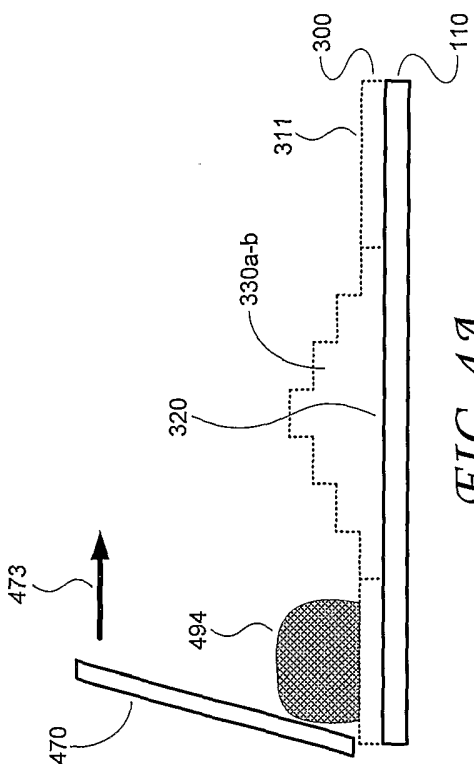

FIG. 4A

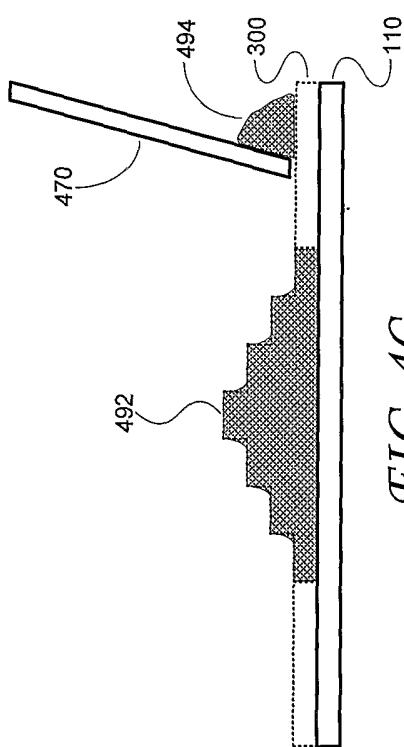

FIG. 4C

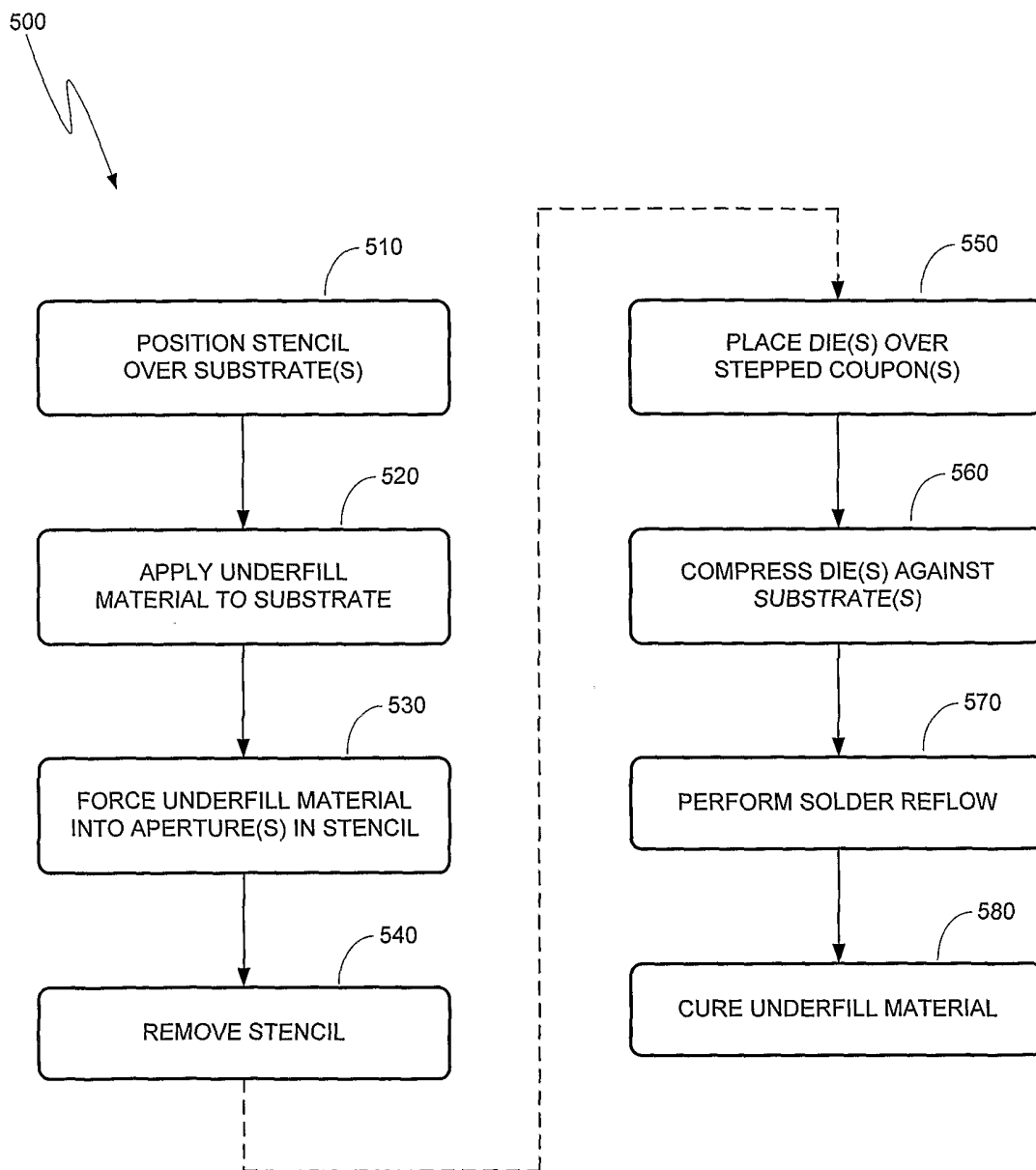

FIG. 5

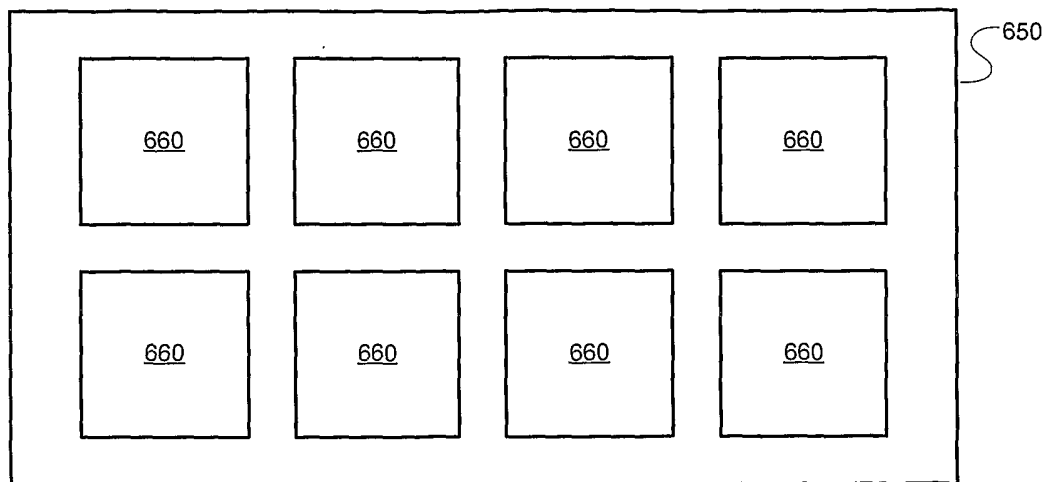

FIG. 6A

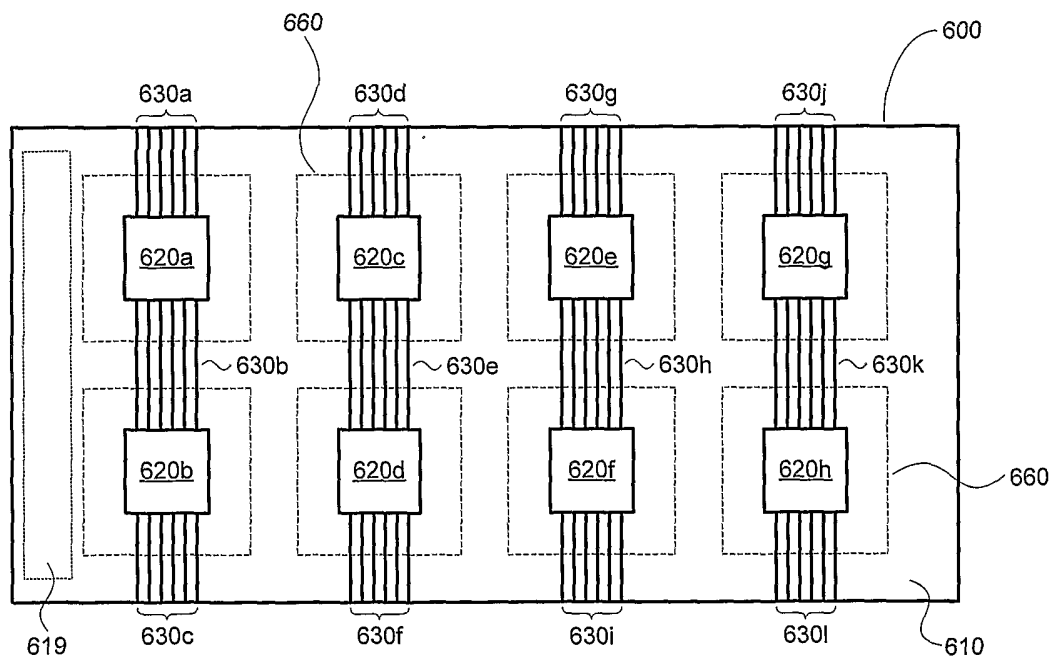

FIG. 6B

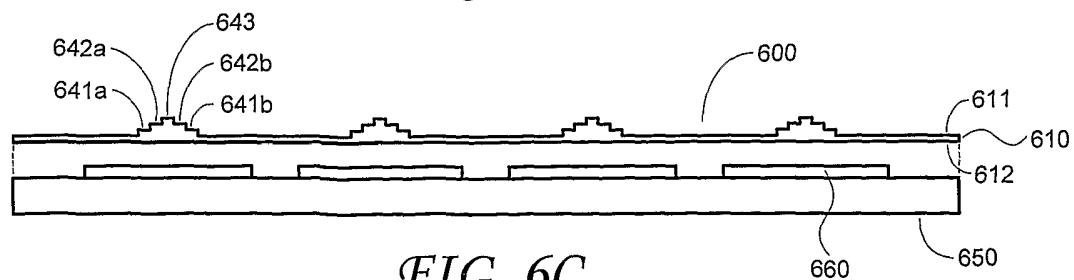

FIG. 6C

INTERNATIONAL SEARCH REPORT

International Application No
PCT/US2004/012019

A. CLASSIFICATION OF SUBJECT MATTER IPC 7 H01L21/56				
According to International Patent Classification (IPC) or to both national classification and IPC				
B. FIELDS SEARCHED				
Minimum documentation searched (classification system followed by classification symbols) IPC 7 H01L H05K				
Documentation searched other than minimum documentation to the extent that such documents are included in the fields searched				
Electronic data base consulted during the international search (name of data base and, where practical, search terms used) EPO-Internal, WPI Data, PAJ				
C. DOCUMENTS CONSIDERED TO BE RELEVANT				
Category °	Citation of document, with indication, where appropriate, of the relevant passages	Relevant to claim No.		
X	US 2003/042617 A1 (LEE TECK KHENG) 6 March 2003 (2003-03-06) abstract; figures 10-13,15-17 page 1, paragraph 9 - page 2, paragraph 13	1-10,13, 15-23, 27,29, 31, 33-36, 40-42, 44,45		
X	EP 0 719 638 A (RICOH MICROELECTRONICS CO LTD) 3 July 1996 (1996-07-03) abstract; figure 34	1-9,12, 13,15, 16, 20-22, 28,29, 31,32		
----- -/--				
<input checked="" type="checkbox"/> Further documents are listed in the continuation of box C.				
<input checked="" type="checkbox"/> Patent family members are listed in annex.				
° Special categories of cited documents :				
<table style="width: 100%; border: none;"> <tr> <td style="width: 50%; vertical-align: top; padding: 5px;"> *A* document defining the general state of the art which is not considered to be of particular relevance *E* earlier document but published on or after the international filing date *L* document which may throw doubts on priority claim(s) or which is cited to establish the publication date of another citation or other special reason (as specified) *O* document referring to an oral disclosure, use, exhibition or other means *P* document published prior to the international filing date but later than the priority date claimed </td> <td style="width: 50%; vertical-align: top; padding: 5px;"> *T* later document published after the international filing date or priority date and not in conflict with the application but cited to understand the principle or theory underlying the invention *X* document of particular relevance; the claimed invention cannot be considered novel or cannot be considered to involve an inventive step when the document is taken alone *Y* document of particular relevance; the claimed invention cannot be considered to involve an inventive step when the document is combined with one or more other such documents, such combination being obvious to a person skilled in the art. *Z* document member of the same patent family </td> </tr> </table>			*A* document defining the general state of the art which is not considered to be of particular relevance *E* earlier document but published on or after the international filing date *L* document which may throw doubts on priority claim(s) or which is cited to establish the publication date of another citation or other special reason (as specified) *O* document referring to an oral disclosure, use, exhibition or other means *P* document published prior to the international filing date but later than the priority date claimed	*T* later document published after the international filing date or priority date and not in conflict with the application but cited to understand the principle or theory underlying the invention *X* document of particular relevance; the claimed invention cannot be considered novel or cannot be considered to involve an inventive step when the document is taken alone *Y* document of particular relevance; the claimed invention cannot be considered to involve an inventive step when the document is combined with one or more other such documents, such combination being obvious to a person skilled in the art. *Z* document member of the same patent family
A document defining the general state of the art which is not considered to be of particular relevance *E* earlier document but published on or after the international filing date *L* document which may throw doubts on priority claim(s) or which is cited to establish the publication date of another citation or other special reason (as specified) *O* document referring to an oral disclosure, use, exhibition or other means *P* document published prior to the international filing date but later than the priority date claimed	*T* later document published after the international filing date or priority date and not in conflict with the application but cited to understand the principle or theory underlying the invention *X* document of particular relevance; the claimed invention cannot be considered novel or cannot be considered to involve an inventive step when the document is taken alone *Y* document of particular relevance; the claimed invention cannot be considered to involve an inventive step when the document is combined with one or more other such documents, such combination being obvious to a person skilled in the art. *Z* document member of the same patent family			
Date of the actual completion of the international search <p style="text-align: center;">17 August 2004</p>	Date of mailing of the international search report <p style="text-align: center;">25/08/2004</p>			
Name and mailing address of the ISA European Patent Office, P.B. 5818 Patentlaan 2 NL - 2280 HV Rijswijk Tel. (+31-70) 340-2040, Tx. 31 651 epo nl, Fax: (+31-70) 340-3016	Authorized officer <p style="text-align: center;">Favre, P</p>			

INTERNATIONAL SEARCH REPORT

International Application No

PCT/US2004/012019

C.(Continuation) DOCUMENTS CONSIDERED TO BE RELEVANT

Category °	Citation of document, with indication, where appropriate, of the relevant passages	Relevant to claim No.
X	US 5 359 928 A (BLESSINGTON DECEASED DANIEL R ET AL) 1 November 1994 (1994-11-01) abstract; figures 1,3 -----	1,7

INTERNATIONAL SEARCH REPORT

Information on patent family members

International Application No
PCT/US2004/012019

Patent document cited in search report	Publication date	Patent family member(s)	Publication date
US 2003042617	A1	06-03-2003	NONE
<hr/>			
EP 0719638	A	03-07-1996	JP 3238029 B2 10-12-2001
			JP 8192585 A 30-07-1996
			AT 193678 T 15-06-2000
			DE 69517400 D1 13-07-2000
			DE 69517400 T2 04-01-2001
			DK 719638 T3 14-08-2000
			EP 0719638 A2 03-07-1996
			EP 0943429 A2 22-09-1999
			EP 0943430 A2 22-09-1999
			EP 0985526 A1 15-03-2000
			ES 2146707 T3 16-08-2000
			GR 3034283 T3 29-12-2000
			JP 3271885 B2 08-04-2002
			JP 8238743 A 17-09-1996
			PT 719638 T 29-09-2000
			US 6063476 A 16-05-2000
			US 6170394 B1 09-01-2001
			US 5887520 A 30-03-1999
			JP 8252988 A 01-10-1996
<hr/>			
US 5359928	A	01-11-1994	US 5478699 A 26-12-1995
			AT 175500 T 15-01-1999
			DE 69322970 D1 18-02-1999
			DE 69322970 T2 12-08-1999
			DK 664016 T3 30-08-1999
			EP 0664016 A1 26-07-1995
			EP 0850758 A2 01-07-1998
			ES 2129079 T3 01-06-1999
			GR 3029862 T3 30-07-1999
			WO 9318440 A1 16-09-1993
<hr/>			