



- (51) International Patent Classification:
E21B 10/42 (2006.01) E21B 10/62 (2006.01)
E21B 10/43 (2006.01)
- (21) International Application Number:
PCT/US2014/042760
- (22) International Filing Date:
17 June 2014 (17.06.2014)
- (25) Filing Language: English
- (26) Publication Language: English
- (30) Priority Data:
61/836,048 17 June 2013 (17.06.2013) US
- (71) Applicant: **LONGYEAR TM, INC.** [US/US]; 10808 South River Front Parkway, Suite 600, South Jordan, UT 84095 (US).
- (72) Inventors: **CASE, Michael**; 6338 Snowflake Lane, Mississauga, Ontario L5N 6G8 (CA). **HOGAN, Jeff**; 36 Elliot Street, Brampton, Ontario L6Y 1W1 (CA). **MATKAR, Tushar**; 5417 Festival Drive, Mississauga, Ontario L5M 0G7 (CA).
- (74) Agents: **DECARLO, Kean, J.** et al.; Ballard Spahr LLP, 999 Peachtree Street, Suite 1000, Atlanta, GA 30309 (US).
- (81) Designated States (*unless otherwise indicated, for every kind of national protection available*): AE, AG, AL, AM, AO, AT, AU, AZ, BA, BB, BG, BH, BN, BR, BW, BY, BZ, CA, CH, CL, CN, CO, CR, CU, CZ, DE, DK, DM,

[Continued on next page]

(54) Title: HIGH-PRODUCTIVITY DRILL BITS

(57) Abstract: Drill bits having flushing channels and surface features that cooperate to evacuate cuttings. The surface features can be provided as flutes, fins, and/or ribs defined in a body portion of the bits. Optionally, the surface features can define back-cutting edges the permit back reaming.



WO 2014/204975 A1

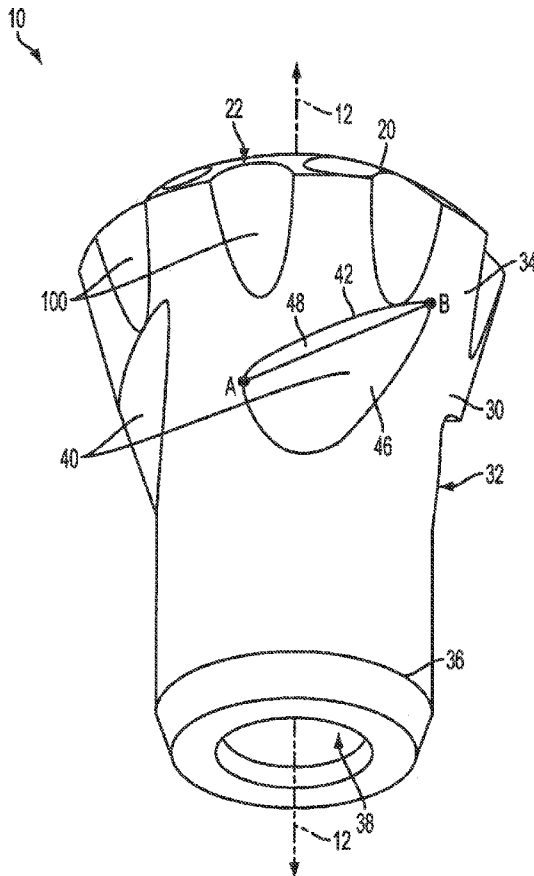

FIG. 1A



DO, DZ, EC, EE, EG, ES, FI, GB, GD, GE, GH, GM, GT, HN, HR, HU, ID, IL, IN, IR, IS, JP, KE, KG, KN, KP, KR, KZ, LA, LC, LK, LR, LS, LT, LU, LY, MA, MD, ME, MG, MK, MN, MW, MX, MY, MZ, NA, NG, NI, NO, NZ, OM, PA, PE, PG, PH, PL, PT, QA, RO, RS, RU, RW, SA, SC, SD, SE, SG, SK, SL, SM, ST, SV, SY, TH, TJ, TM, TN, TR, TT, TZ, UA, UG, US, UZ, VC, VN, ZA, ZM, ZW.

EE, ES, FI, FR, GB, GR, HR, HU, IE, IS, IT, LT, LU, LV, MC, MK, MT, NL, NO, PL, PT, RO, RS, SE, SI, SK, SM, TR), OAPI (BF, BJ, CF, CG, CI, CM, GA, GN, GQ, GW, KM, ML, MR, NE, SN, TD, TG).

(84) Designated States (unless otherwise indicated, for every kind of regional protection available): ARIPO (BW, GH, GM, KE, LR, LS, MW, MZ, NA, RW, SD, SL, SZ, TZ, UG, ZM, ZW), Eurasian (AM, AZ, BY, KG, KZ, RU, TJ, TM), European (AL, AT, BE, BG, CH, CY, CZ, DE, DK,

Declarations under Rule 4.17:

— as to applicant's entitlement to apply for and be granted a patent (Rule 4.17(ii))

Published:

— with international search report (Art. 21(3))

HIGH-PRODUCTIVITY DRILL BITS

CROSS-REFERENCE TO RELATED APPLICATION

[0001] This application claims the benefit of the filing date of U.S. Provisional Patent Application No. 61/836,048, filed June 17, 2013, which is incorporated by reference herein in its entirety.

FIELD

[0002] This invention relates to a bit for use in drilling operations and, more particularly, to drill bits for evacuating cuttings from a drill hole.

BACKGROUND

[0003] In current in-hole reaming applications, the total drilling time is significantly less than the time required to remove a drill string from a hole. The removal of the drill string is typically slowed down by the jamming of cuttings behind the bit face. Drill string removal takes even longer under adverse ground conditions, such as soft and/or broken ground conditions. Under these adverse conditions, conventional drill strings are often lost in the hole.

[0004] Thus, there is a need in the pertinent art for reaming bits that improve evacuation of cuttings within a drill hole and expedite the removal of drill strings from a drill hole.

SUMMARY

[0005] Described herein is a bit for use in drilling operations, such as forming a hole within a formation. Optionally, the formation can comprise rock. The bit can have a central longitudinal axis, a bit face having a top surface, and a body portion extending axially away from the bit face. The body portion of the bit can have an exterior surface and a proximal portion that defines a plurality of surface features. At least a portion of each surface feature can be configured for back reaming during formation of the hole. The body portion and the bit face can cooperate to define a plurality of circumferentially spaced flushing channels. The plurality of surface features can cooperate with the plurality of flushing channels to remove cuttings from the hole as the hole is formed.

[0006] Optionally, the plurality of surface features can be a plurality of flutes defined within the exterior surface of the body portion. Each flute can be angularly oriented relative to the central longitudinal axis.

[0007] Optionally, the plurality of surface features can be a plurality of fins that project outwardly from the body portion. Each fin of the plurality of fins can optionally be positioned in communication with at least one flushing channel of the plurality of flushing channels.

[0008] Optionally, the plurality of surface features can be a plurality of ribs that project outwardly from the proximal portion of the body portion. Each rib of the plurality of ribs can optionally be positioned in communication with at least one flushing channel of the plurality of flushing channels. Each rib of the plurality of ribs can optionally be angularly oriented relative to the central longitudinal axis.

[0009] Optionally, the top surface of the bit face can have a generally rounded profile. The bit face can define at least one projection that extends from the top surface of the bit face. The top surface of the bit face can define at least one bore proximate the central axis of the bit. The at least one bore can extend into an interior portion of the bit. The bore can be positioned in fluid communication with a longitudinally extending central channel defined within the bit. In one aspect, the central channel can be in selective communication with a source of pressurized flushing medium. The pressurized flushing medium can be provided to the top surface of the bit face via the fluidly connected central channel and the at least one bore.

[0010] In use, the drill bit can allow cuttings to be removed from a formed hole. The cuttings can generally be carried through the flushing channels by the pressurized flushing medium that is confined between the flushing channels of the drill bit and the inner wall surface of the formed hole.

[0011] Additional advantages of the invention will be set forth in part in the description which follows, and in part will be obvious from the description, or may be learned by practice of the invention. The advantages of the invention will be realized and attained by means of the elements and combinations particularly pointed out in the appended claims. It is to be understood that both the foregoing general description and the following detailed description are exemplary and explanatory only and are not restrictive of the invention, as claimed.

DETAILED DESCRIPTION OF THE FIGURES

[0012] These and other features of the preferred embodiments of the invention will become more apparent in the detailed description in which reference is made to the appended drawings wherein:

[0013] Figures 1A-3B depict exemplary reaming bits as disclosed herein. The reaming bits of Figures 1A-3B have a plurality of spaced flutes that define a leading (cutting) edge.

[0014] Figure 1A is a front perspective view of an exemplary reaming bit, and Figure 1B provides various technical views of the reaming bit. Figure 1C is an isolated side view of an exemplary flute of a drill bit as disclosed herein. Figure 1D is a cross-sectional view of an exemplary drill bit, taken along a first wall surface, which is exemplarily shown positioned in a first plane that contains a planar chord as disclosed herein.

[0015] Figure 2 depicts a front perspective view of another exemplary reaming bit.

[0016] Figure 3A is a front perspective view of an exemplary reaming bit, and Figure 3B provides various technical views of the reaming bit.

[0017] Figures 4A-4B schematically depict the formation of a flute on the outer surface of a reaming bit as disclosed herein. The orientation of the reaming bit depicted in Figure 4A corresponds to the relative orientation of the reaming bit when a straight cut was made into the bit to form the flute. In operation, when the reaming bit is rotated until its central axis is substantially within the plane of the drawing page (see the orientation of the reaming bit depicted in Figure 4B), the angular orientation of the flute relative to the central axis of the bit is visible.

[0018] Figures 5A and 5B depict an exemplary reaming bit having four circumferentially spaced flutes as disclosed herein. Figure 5C depicts an exemplary reaming bit having five circumferentially spaced flutes as disclosed herein. Figures 5D and 5E depict an exemplary reaming bit having six circumferentially spaced flutes as disclosed herein.

[0019] Figure 6 depicts a drill bit having optional fin elements and straight ribs, which, as further disclosed herein, can be used in place of or in conjunction with the helical flutes disclosed herein.

[0020] Figure 7 depicts another exemplary reaming bit as disclosed herein. The reaming bit of Figure 7 has at least two angled flutes, with at least one angled flute placed on each side of the bit face.

[0021] Figure 8 depicts an exemplary pilot reamer having back cutting edges as disclosed herein.

[0022] Figures 9A-9D depicts an exemplary reaming bit having back cutting edges as disclosed herein.

[0023] Figures 10A-10B are images of an exemplary reaming bit as disclosed herein prior to experimental testing.

[0024] Figures 11A-11B are images of the reaming bit of Figures 10A-10B following completion of experimental testing.

DETAILED DESCRIPTION

[0025] The present invention can be understood more readily by reference to the following detailed description, examples, drawings, and claims, and their previous and following description. However, before the present devices, systems, and/or methods are disclosed and described, it is to be understood that this invention is not limited to the specific devices, systems, and/or methods disclosed unless otherwise specified, as such can, of course, vary. It is also to be understood that the terminology used herein is for the purpose of describing particular aspects only and is not intended to be limiting.

[0026] The following description of the invention is provided as an enabling teaching of the invention in its best, currently known embodiment. To this end, those skilled in the relevant art will recognize and appreciate that many changes can be made to the various aspects of the invention described herein, while still obtaining the beneficial results of the present invention. It will also be apparent that some of the desired benefits of the present invention can be obtained by selecting some of the features of the present invention without utilizing other features. Accordingly, those who work in the art will recognize that many modifications and adaptations to the present invention are possible and can even be desirable in certain circumstances and are a part of the present invention. Thus, the following description is provided as illustrative of the principles of the present invention and not in limitation thereof.

[0027] As used throughout, the singular forms “a,” “an” and “the” include plural referents unless the context clearly dictates otherwise. Thus, for example, reference to “a flushing channel” can include two or more such flushing channels unless the context indicates otherwise.

[0028] Ranges can be expressed herein as from “about” one particular value, and/or to “about” another particular value. When such a range is expressed, another aspect includes from the one particular value and/or to the other particular value. Similarly, when values are expressed as approximations, by use of the antecedent “about,” it will be understood that the particular value forms another aspect. It will be further understood that the endpoints of each of the ranges are significant both in relation to the other endpoint, and independently of the other endpoint.

[0029] As used herein, the terms “optional” or “optionally” mean that the subsequently described event or circumstance may or may not occur, and that the description includes instances where said event or circumstance occurs and instances where it does not.

[0030] The word “or” as used herein means any one member of a particular list and also includes any combination of members of that list.

[0031] Described herein with reference to Figures 1A-11B is a drill bit for use in drilling operations. In exemplary operations, the drill bit can form a hole within a drilling formation. Optionally, in some exemplary operations, the drilling formation can comprise rock. As described further herein, it is contemplated that the drill bits disclosed herein can increase drilling productivity without adding guidance features. Optionally, the drill bit can be a reaming bit. However, it is contemplated that the features disclosed herein can be employed in threaded bits (including, for example and without limitation, flat-face bits), down-the-hole bits, dome bits/hole-opener bits, pilot reamers, and the like without limitation.

[0032] In one aspect, the drill bit 10 can have a central longitudinal axis 12, a bit face 20 having a top surface 22, and a body portion 30 extending axially away from the bit face. As shown in Figures 1A-11B, it is contemplated that the top surface 22 of the bit face 20 can have a generally rounded profile. In another aspect, as shown in Figures 7, 10A-10B, and 11A-11B, the bit face 20 can optionally define, or be coupled to, at least one projection 26 or other surface element as is conventionally known in the art. In this aspect, it is contemplated that the at least one projection 26 can comprise a plurality of projections. In an additional aspect, the bit face 20

can define at least one bore 24. Optionally, the at least one bore 24 can be positioned proximate the central longitudinal axis 12 of the bit 10. In one aspect, it is contemplated that the at least one bore 24 can extend into an interior portion of the bit. It is further contemplated that the at least one bore can be configured to deliver fluid proximate the bit face.

[0033] In one aspect, at least one bore 24 can be in fluid communication with a longitudinally extending central channel 38 defined within the interior portion of the bit 10. In one aspect, the central channel 38 can be in selective communication with a source of pressurized flushing medium. In this aspect, it is contemplated that the pressurized flushing medium can be provided to the bit face 20 via the fluidly connected central channel 38 and the at least one bore 24. Optionally, in one exemplary aspect, at least one bore of the at least one bore 24 can be defined by the top surface 22 of the bit face 20. In this aspect, it is contemplated that a plurality of bores 24 can be defined by the top surface 22 of the bit face 20. In other exemplary aspects, it is contemplated that at least one bore of the at least one bore 24 can be defined by a side portion of the bit face 20. In further aspects, it is contemplated that the at least one bore 24 can be defined by a side portion of the body portion 30 of the drill bit 10 proximate the bit face 20.

[0034] In another aspect, the body portion 30 of the drill bit can have an exterior surface 32, a proximal portion 34, and a distal portion 36. In this aspect, the proximal portion 34 can define a plurality of surface features.

[0035] In a further aspect, as shown in Figures 1A-7 and 10A-11B, the body portion 30 of the bit 10 can cooperate with the bit face 20 to define a plurality of circumferentially spaced flushing channels 100. In this aspect, the plurality of surface features can cooperate with the plurality of flushing channels 100 to remove cuttings from the hole as the hole is formed. In this aspect, it is contemplated that the plurality of flushing channels 100 can be substantially equally spaced about the circumference of the bit face 20. In exemplary aspects, the plurality of flushing channels 100 can comprise 3, 4, 5, or 6 flushing channels (See Figures 5A-5E). However, it is contemplated that the plurality of flushing channels 100 can comprise any number of flushing channels that permits evacuation of cuttings as disclosed herein.

Drill Bits Having a Plurality of Flutes

[0036] In an exemplary aspect, as shown in Figures 1A-5E, 7, and 10A-11B, the plurality of surface features can comprise a plurality of flutes 40. In this aspect, each flute 40 of the plurality of flutes can be angularly oriented relative to the central axis 12 of the bit 10. Optionally, it is contemplated that at least a portion of each flute 40 can form a cutting element 42 configured for back reaming. In an additional aspect, it is contemplated that the cutting element 42 of each flute 40 of the plurality of flutes can define a cutting (leading) edge 44.

[0037] Optionally, it is contemplated that that at least one flute 40 can be positioned in fluid communication with at least one flushing channel 100. In exemplary aspects, a portion of each flute 40 of the plurality of flutes can be configured for fluid communication with a portion of at least one flushing channel 100 of the plurality of flushing channels. However, it is contemplated that any configuration of flutes 40 and flushing channels 100 can be used. For example, in some aspects, it is contemplated that the plurality of flutes 40 can function independently of the plurality of flushing channels 100. In these aspects, it is contemplated that the plurality of flutes 40 can be spaced from the plurality of flushing channels 100 relative to the central axis 12 of the bit 10. Thus, it is contemplated that the at least one flute 40 can be configured to be in fluid communication with the at least one flushing channel 100 and that, alternatively, in other exemplary aspects, the at least one flute 40 can be configured to not be in fluid communication with the at least one flushing channel 100.

[0038] In one exemplary aspect, each flute 40 can comprise a first wall surface 46 (substantially positioned within a first plane 47) and a second wall surface 48 (substantially positioned within a second plane 49). In this aspect, the first and second wall surfaces 46, 48 can be defined by the exterior surface 32 of the proximal portion 34 of the body portion 30 of the bit 10. In another aspect, it is contemplated that the second plane 49 (substantially containing the second wall surface 48) can be positioned at a selected orientation angle 50 relative to the first plane 47 (substantially containing the first wall surface 46). In one exemplary aspect, the orientation angle 50 can range from about 30° to about 130°. In another exemplary aspect, the orientation angle 50 can range from about 60° to about 100°. In yet another aspect, the orientation angle 50 can range from about 80° to about 95°. Optionally, it is contemplated that

the second plane 49 (substantially containing the second wall surface 48) can be substantially transverse to the first plane 47 (substantially containing the first wall surface 46).

[0039] As illustrated in Figures 1A-5E and specifically shown in Figures 1B and 1D, the first plane 47 (substantially containing the first wall surface 46) can contain a planar chord AB extending from a first end point A to a second end point B. It is contemplated that the second end point B can be axially spaced from the first end point A in the direction of the bit face 20 relative to the longitudinal axis 12 of the bit 10. It is further contemplated that the second end point B can be positioned at the intersection of the first wall surface 46 and the exterior circumferential surface 32 of the body portion 30 of the bit 10. Optionally, the planar chord AB can be positioned substantially at the boundary between the first wall surface 46 and the second wall surface 48 (and substantially at the intersection between the first plane 47 and the second plane 49). In exemplary aspects, the planar chord AB can have a chord angle 54 that exemplarily ranges from about 5° to about 80° , where the chord angle is the angle formed by the planar chord AB and a tangent line 56 within the first plane 47. In these aspects, the planar chord AB and the tangent line 56 can intersect on the exterior circumferential surface 32 of the body portion 30 of the bit 10 at the second end point B. In other exemplary aspects, the chord angle 54 can range from about 20° to about 70° . In still other aspects, the chord angle 54 can range from about 30° to about 65° . In a further exemplary aspect, the chord angle 54 can be about 40° .

[0040] In a further aspect, and with reference to Figure 1B, it is contemplated that the second wall surface 48 can be positioned such that a normal (perpendicular line) 64 extending from the second plane 49 (substantially containing the second wall surface) is positioned at a selected cutting angle 66 relative to the longitudinal axis 12 of the bit 10. In this aspect, it is contemplated that the selected cutting angle 66 can range from about 10° to about 120° relative to the longitudinal axis 12 of the bit 10. In another aspect, it is contemplated that the selected cutting angle 66 can range from about 20° to about 100° relative to the longitudinal axis 12 of the bit 10. In a further aspect, it is contemplated that the selected cutting angle 66 can range from about 25° to about 90° relative to the longitudinal axis 12 of the bit 10. In still another aspect, it is contemplated that the selected cutting angle 66 can range from about 30° to about 65° . In one exemplary aspect, the selected cutting angle 66 can be about 40° .

[0041] Optionally, it is contemplated that each flute 40 of the plurality of flutes can have a substantially helical profile. In an additional aspect, the cutting element 42 of each helically shaped flute 40 of the plurality of flutes can define a leading (cutting) edge 44 that is configured for back reaming.

[0042] Optionally, in other exemplary aspects, as shown in Figure 7, it is contemplated that the plurality of helical flutes 40 can be positioned in a substantially vertical orientation. In these aspects, it is contemplated that at least one flute 40 of the plurality of flutes can cooperate with at least one flushing channel to define a continuous pathway for receiving fluid and/or cuttings as disclosed herein. Optionally, it is contemplated that each flute 40 of the plurality of flutes can be oriented substantially parallel to the longitudinal axis 12 of the bit 10.

Drill Bits Having a Back Face with a Cutting Profile

[0043] Optionally, in exemplary aspects, and with reference to Figures 8-9D, it is contemplated that the proximal portion 34 of the body portion 30 of the bit 10 can have a back face 90 that is provided with a cutting profile 92 that comprises at least one cutting edge 94 that is configured for back reaming. In exemplary aspects, the at least one cutting edge 94 defined on the back face 90 can have a substantially saw-tooth cutting profile. It is contemplated that the at least one cutting edge 94 of the back face 90 can be configured to cut and/or agitate cuttings, thereby promoting removal of the bit 10 from the hole and increasing the productivity of drilling operations.

[0044] In exemplary aspects, the cutting profile 92 can comprise a plurality of back cutting teeth 96. In these aspects, the plurality of teeth 96 can be circumferentially spaced about the back face 90. Optionally, it is contemplated that the plurality of teeth 96 can be substantially equally circumferentially spaced about the back face 90. In an additional aspect, it is contemplated that each tooth 96 of the plurality of teeth can define a respective cutting edge 94 of the back face 90. In one exemplary aspect, the plurality of back cutting teeth 96 can comprise three back cutting teeth.

[0045] In other aspects, the cutting profile 92 can comprise a plurality of recessed portions 98 positioned between adjacent teeth 96 of the plurality of back cutting teeth. For example, in one aspect, when the plurality of back cutting teeth 96 comprises three teeth, it is contemplated that the plurality of recessed portions 98 can comprise three recessed portions. In further

aspects, the recessed portions 98 can be defined by corresponding sloped portions 93 of the cutting profile 92. In these aspects, as shown in Figures 9B-9D, it is contemplated that the sloped portions 93 of the cutting profile 92 can be oriented at a selected angle 99 relative to a plane 95 positioned perpendicular to the longitudinal axis 12 of the bit 10. It is further contemplated that the selected angle 99 can range from about 5° to about 45°. In one exemplary aspect, it is contemplated that the selected angle 99 can range from about 10° to about 30°. In another exemplary aspect, it is contemplated that the selected angle 99 can range from about 15° to about 20°.

Drill Bits Having a Plurality of Fins

[0046] In another exemplary aspect, and with reference to Figure 6, the plurality of surface features of the drill bit can optionally comprise a plurality of fins 70 that project outwardly from the body portion 30 of the bit 10. In this aspect, the plurality of fins 70 can be configured to act as cutting elements that are configured for back reaming. In this aspect, it is contemplated that at least one fin 70 of the plurality of fins can be positioned in communication with at least one flushing channel 100 of the bit 10. It is further contemplated that each fin 70 of the plurality of fins can be positioned in communication with at least one flushing channel 100 of the bit 10. However, it is contemplated that any configuration of fins 70 and flushing channels 100 can be used. For example, in some aspects, it is contemplated that the plurality of fins 70 can function independently of the plurality of flushing channels 100. In these aspects, it is contemplated that the plurality of fins 70 can be spaced from the plurality of flushing channels 100 relative to the central axis 12 of the bit 10. Thus, it is contemplated that the at least one fin 70 can be configured to be in fluid communication with the at least one flushing channel 100 and that, alternatively, in other exemplary aspects, the at least one fin 70 can be configured to not be in fluid communication with the at least one flushing channel 100.

[0047] It is further optionally contemplated that the fins 70 can optionally have a substantially helical profile. In use, it is contemplated that the fins 70 can function in the same general manner as the flutes disclosed herein, thereby improving productivity of drilling operations.

Drill Bits Having a Plurality of Ribs

[0048] In still another exemplary aspect, and with reference to Figure 6, the plurality of surface features of the drill bit 10 can optionally comprise a plurality of ribs 80 that project outwardly from the body portion 30 of the bit 10. In this aspect, the plurality of ribs 80 can be configured to act as cutting elements that are configured for back reaming. In this aspect, it is contemplated that at least one rib 80 can be positioned in fluid communication with at least one flushing channel 100 of the bit. It is further contemplated that each rib 80 of the plurality of ribs can be positioned in communication with at least one flushing channel 100 of the bit 10. However, it is contemplated that any configuration of ribs 80 and flushing channels 100 can be used. For example, in some aspects, it is contemplated that the plurality of ribs 80 can function independently of the plurality of flushing channels 100. In these aspects, it is contemplated that the plurality of ribs 80 can be spaced from the plurality of flushing channels 100 relative to the central axis 12 of the bit 10. Thus, it is contemplated that the at least one rib 80 can be configured to be in fluid communication with the at least one flushing channel 100 and that, alternatively, in other exemplary aspects, the at least one rib 80 can be configured to not be in fluid communication with the at least one flushing channel 100.

[0049] It is further contemplated that the ribs 80 can be positioned at a selected angle relative to the central axis 12 of the bit. In use, it is contemplated that the ribs 80 can function in the same general manner as the flutes and fins disclosed herein, thereby improving productivity of drilling operations.

[0050] In exemplary aspects, it is contemplated that the plurality of surface features can comprise at least two of the flutes 40, fins 70, and ribs 80 as disclosed herein. Thus, it is contemplated that the plurality of surface features can comprise at least one flute 40 and at least one fin 70. Similarly, it is contemplated that the plurality of surface features can comprise at least one flute 40 and at least one rib 80. It is further contemplated that the plurality of surface features can comprise at least one fin 70 and at least one rib 80. It is still further contemplated that the plurality of surface features can comprise at least one flute 40, at least one fin 70, and at least one rib 80.

Use of the Drill Bits

[0051] In use, it is contemplated that the disclosed drill bit can be placed into contact with a formation and advanced relative to the formation in a conventional manner to form a drill hole. It is contemplated that the plurality of surface features can cooperate with the plurality of flushing channels to evacuate cuttings and thereby promote removal of the drill string from a drill hole, such as, for example and without limitation, a drill hole formed within a rock formation. It is contemplated that the cuttings can be generally carried through the flushing channels and the surface features by the pressurized flushing medium that is generally confined between the flushing channels and an inner wall surface of the formed hole. It is further contemplated that the absence of guidance diameter on the bit can permit the bit to better follow a pilot hole and “float” within the reamed hole without contacting the interior edges of the hole.

[0052] In operation, it is contemplated that drill strings comprising one of the disclosed drill bits can be removed from a hole more quickly and with less resistance than drill strings comprising a conventional drill bit. More particularly, it is contemplated that the disclosed drill bits can increase productivity by biting into jammed cuttings and effectively evacuating the cuttings through the flushing channels and other surface features disclosed herein.

Examples

[0053] In one experimental test, the performance of a high-productivity reaming bit as disclosed herein was compared to the performance of a conventional reaming bit. Both bits were connected to a Montabert drilling machine and used to drill four 16-foot holes in unconsolidated broken ground. Figures 10A-10B display images of the high-productivity reaming bit prior to drilling of the holes. Figures 11A-11B display images of the high-productivity reaming bit after drilling of the holes.

[0054] The high-productivity reaming bit was able to penetrate 16 feet within about three minutes. The extraction time for the high-productivity reaming bit was around ten seconds on average, whereas the extraction time for the conventional reaming bit was around eight minutes on average. The high-productivity reaming bit exhibited more stability (less wandering) compared to the conventional reaming bit, and the high-productivity reaming bit produced straighter holes than the conventional reaming bit.

Exemplary Drill Bits

[0055] In exemplary aspects, a drill bit for forming a hole within a formation is provided, the drill bit having a central longitudinal axis and comprising: a bit face having a top surface; and a body portion extending axially away from the bit face, the body portion having an exterior surface and a proximal portion that defines a plurality of flutes within the exterior surface of the body portion, each flute of the plurality of flutes being angularly oriented relative to the central longitudinal axis, wherein the body portion and the bit face cooperate to define a plurality of circumferentially spaced flushing channels, and wherein the plurality of flutes cooperate with the plurality of flushing channels to remove cuttings from the hole as the hole is formed.

[0056] In another exemplary aspect, the body portion defines a central channel configured to receive a flushing medium, wherein the top surface of the bit face defines at least one bore positioned in fluid communication with the central channel.

[0057] In another exemplary aspect, at least a portion of each flute forms a cutting element configured for back reaming.

[0058] In another exemplary aspect, each flute of the plurality of flutes comprises a first substantially planar wall surface and a second substantially planar wall surface.

[0059] In another exemplary aspect, the first wall surface of each flute of the plurality of flutes is positioned in a first plane containing a planar chord that has a chord angle formed by the planar chord and a tangent line within the first plane that intersect on the exterior surface of the body portion at an end intersection of the first wall surface and the exterior surface of the body portion, wherein the chord angle ranges from about 5° to about 60°.

[0060] In another exemplary aspect, the second wall surface of each flute of the plurality of flutes is positioned in a second plane positioned at an orientation angle relative to the first plane, wherein the orientation angle ranges from about 30° to about 130°. In another exemplary aspect, the orientation angle ranges from about 60° to about 100°. In another exemplary aspect, the orientation angle ranges from about 80° to about 95°. In another exemplary aspect, the second wall surface is substantially transverse to the first wall surface.

[0061] In another exemplary aspect, the second wall surface is positioned such that a normal extending from the second wall surface is positioned at a cutting angle with respect to the central longitudinal axis of the drill bit.

[0062] In another exemplary aspect, the cutting angle ranges from about 10° to about 120°. In another exemplary aspect, the cutting angle ranges from about 20° to about 100°. In another exemplary aspect, the cutting angle ranges from about 25° to about 90°.

[0063] In another exemplary aspect, each flute of the plurality of flutes has a substantially helical profile.

[0064] In another exemplary aspect, the bit face defines at least one projection extending from the top surface of the drill bit.

[0065] In other exemplary aspects, a drill bit for forming a hole within a formation can be provided, the drill bit having a central longitudinal axis and comprising: a bit face having a top surface; and a body portion extending axially away from the bit face, the body portion having an exterior surface and a proximal portion that defines a plurality of surface features, wherein the body portion and the bit face cooperate to define a plurality of circumferentially spaced flushing channels, and wherein the plurality of surface features cooperate with the plurality of flushing channels to remove cuttings from the hole as the hole is formed.

[0066] In another exemplary aspect, the plurality of surface features comprise a plurality of flutes defined within the exterior surface of the body portion, each flute of the plurality of flutes being angularly oriented relative to the central longitudinal axis.

[0067] In another exemplary aspect, the plurality of surface features comprise a plurality of fins that project outwardly from the body portion, wherein each fin of the plurality of fins is positioned in communication with at least one flushing channel of the plurality of flushing channels. In another exemplary aspect, each rib of the plurality of fins is spaced from the plurality of flushing channels such that the plurality of fins function independently of the plurality of flushing channels.

[0068] In another exemplary aspect, the plurality of surface features comprise a plurality of ribs that project outwardly from the proximal portion of the body portion, wherein each rib of the plurality of ribs is positioned in communication with at least one flushing channel of the plurality

of flushing channels. In another exemplary aspect, each rib of the plurality of ribs is spaced from the plurality of flushing channels such that the plurality of ribs function independently of the plurality of flushing channels.

[0069] In another exemplary aspect, each rib of the plurality of ribs has a longitudinal axis that is angularly oriented relative to a plane containing the central longitudinal axis of the drill bit.

[0070] In another exemplary aspect, at least a portion of each surface feature of the plurality of surface features is configured for back reaming,

[0071] In a further exemplary aspect, a method of forming a hole within a formation comprises: positioning a drill bit in contact with a formation, the drill bit having a central longitudinal axis and comprising: a bit face having a top surface; and a body portion extending axially away from the bit face, the body portion having an exterior surface and a proximal portion that defines a plurality of flutes within the exterior surface of the body portion, each flute of the plurality of flutes being angularly oriented relative to the central longitudinal axis, wherein the body portion and the bit face cooperate to define a plurality of circumferentially spaced flushing channels; and advancing the drill bit within the formation to form the hole, wherein the plurality of flutes cooperate with the plurality of flushing channels to remove cuttings from the hole as the hole is formed. In another exemplary aspect, the formation is a rock formation.

[0072] Although several embodiments of the invention have been disclosed in the foregoing specification, it is understood by those skilled in the art that many modifications and other embodiments of the invention will come to mind to which the invention pertains, having the benefit of the teaching presented in the foregoing description and associated drawings. It is thus understood that the invention is not limited to the specific embodiments disclosed hereinabove, and that many modifications and other embodiments are intended to be included within the scope of the appended claims. Moreover, although specific terms are employed herein, as well as in the claims which follow, they are used only in a generic and descriptive sense, and not for the purposes of limiting the described invention, nor the claims which follow.

CLAIMS

What is claimed is:

1. A drill bit for forming a hole within a formation, the drill bit having a central longitudinal axis and comprising:

a bit face having a top surface; and

a body portion extending axially away from the bit face, the body portion having an exterior surface and a proximal portion that defines a plurality of flutes within the exterior surface of the body portion, each flute of the plurality of flutes being angularly oriented relative to the central longitudinal axis,

wherein the body portion and the bit face cooperate to define a plurality of circumferentially spaced flushing channels, and wherein the plurality of flutes cooperate with the plurality of flushing channels to remove cuttings from the hole as the hole is formed.

2. The drill bit of claim 1, wherein the body portion defines a central channel that is configured to receive a flushing medium, and wherein the top surface of the bit face defines at least one bore positioned in fluid communication with the central channel.

3. The drill bit of claim 1, wherein at least a portion of each flute forms a cutting element configured for back reaming.

4. The drill bit of claim 1, wherein each flute of the plurality of flutes comprises a first substantially planar wall surface and a second substantially planar wall surface.

5. The drill bit of claim 4, wherein the first wall surface of each flute of the plurality of flutes is positioned in a first plane containing a planar chord that has a chord angle formed by the planar chord and a tangent line within the first plane that intersect on the exterior surface of the body portion at an end intersection of the first wall surface and the exterior surface of the body portion, wherein the chord angle ranges from about 5° to about 60°.

6. The drill bit of claim 5, wherein the second wall surface of each flute of the plurality of flutes is positioned in a second plane positioned at an orientation angle relative to the first plane, wherein the orientation angle ranges from about 30° to about 130°.

7. The drill bit of claim 6, wherein the orientation angle ranges from about 60° to about 100°.
8. The drill bit of claim 6, wherein the orientation angle ranges from about 80° to about 95°.
9. The drill bit of claim 4, wherein the second wall surface is substantially transverse to the first wall surface.
10. The drill bit of claim 4, wherein the second wall surface is positioned such that a normal extending from the second wall surface is positioned at a cutting angle with respect to the central longitudinal axis of the drill bit.
11. The drill bit of claim 10, wherein the cutting angle ranges from about 10° to about 120°.
12. The drill bit of claim 11, wherein the cutting angle ranges from about 20° to about 100°.
13. The drill bit of claim 11, wherein the cutting angle ranges from about 25° to about 90°.
14. The drill bit of claim 3, wherein each flute of the plurality of flutes has a substantially helical profile.
15. The drill bit of claim 1, wherein the bit face defines at least one projection extending from the top surface of the drill bit.
16. A drill bit for forming a hole within a formation, the drill bit having a central longitudinal axis and comprising:
 - a bit face having a top surface; and
 - a body portion extending axially away from the bit face, the body portion having an exterior surface and a proximal portion that defines a plurality of surface features, wherein the body portion and the bit face cooperate to define a plurality of circumferentially spaced flushing channels, and wherein the plurality of surface features cooperate with the plurality of flushing channels to remove cuttings from the hole as the hole is formed.
17. The drill bit of claim 16, wherein the plurality of surface features comprise a plurality of flutes defined within the exterior surface of the body portion, each flute of the plurality of flutes being angularly oriented relative to the central longitudinal axis.

18. The drill bit of claim 16, wherein the plurality of surface features comprise a plurality of fins that project outwardly from the body portion, wherein each fin of the plurality of fins is positioned in communication with at least one flushing channel of the plurality of flushing channels.

19. The drill bit of claim 16, wherein the plurality of surface features comprise a plurality of ribs that project outwardly from the proximal portion of the body portion, wherein each rib of the plurality of ribs is positioned in communication with at least one flushing channel of the plurality of flushing channels.

20. The drill bit of claim 19, wherein each rib of the plurality of ribs has a longitudinal axis that is angularly oriented relative to a plane containing the central longitudinal axis of the drill bit.

21. The drill bit of claim 16, wherein at least a portion of each surface feature of the plurality of surface features is configured for back reaming,

22. A method of forming a hole within a formation, comprising:

positioning a drill bit in contact with a formation, the drill bit having a central longitudinal axis and comprising:

a bit face having a top surface; and

a body portion extending axially away from the bit face, the body portion having an exterior surface and a proximal portion that defines a plurality of flutes within the exterior surface of the body portion, each flute of the plurality of flutes being angularly oriented relative to the central longitudinal axis,

wherein the body portion and the bit face cooperate to define a plurality of circumferentially spaced flushing channels; and

advancing the drill bit within the formation to form the hole,

wherein the plurality of flutes cooperate with the plurality of flushing channels to remove cuttings from the hole as the hole is formed.

23. The method of claim 22, wherein the formation is a rock formation.

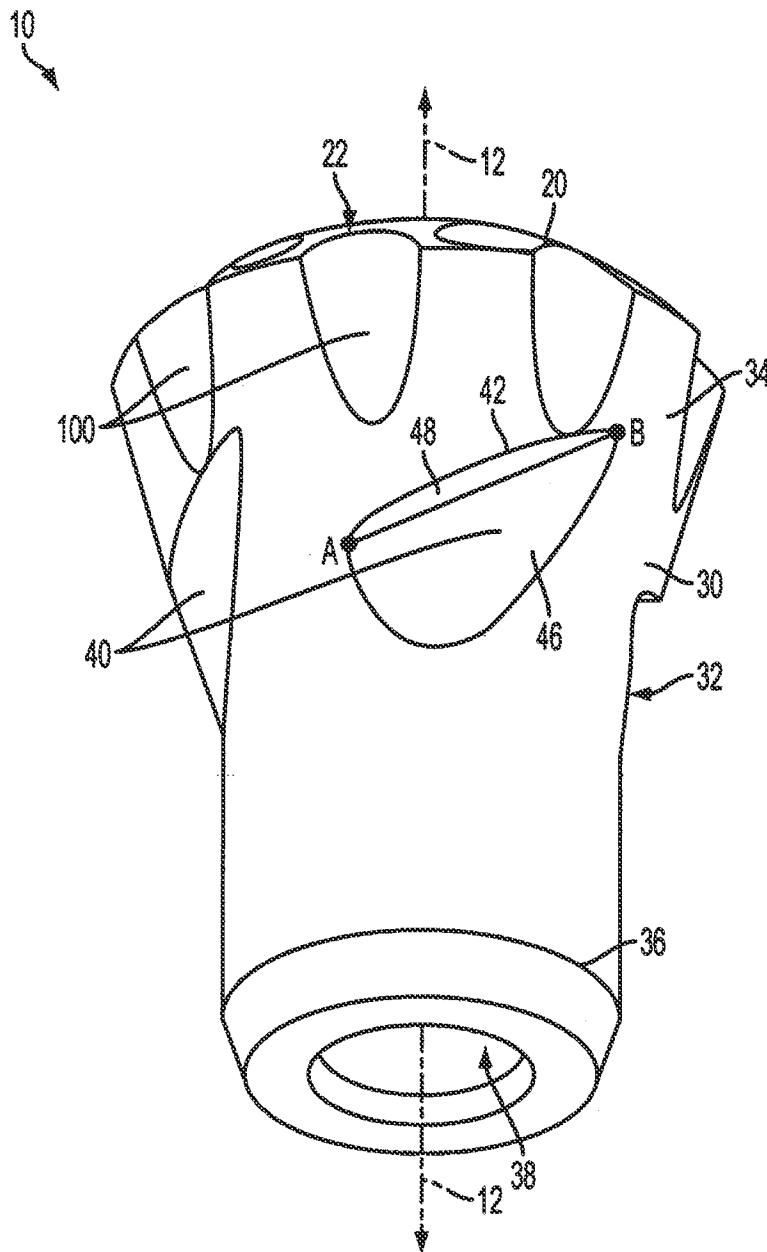

FIG. 1A

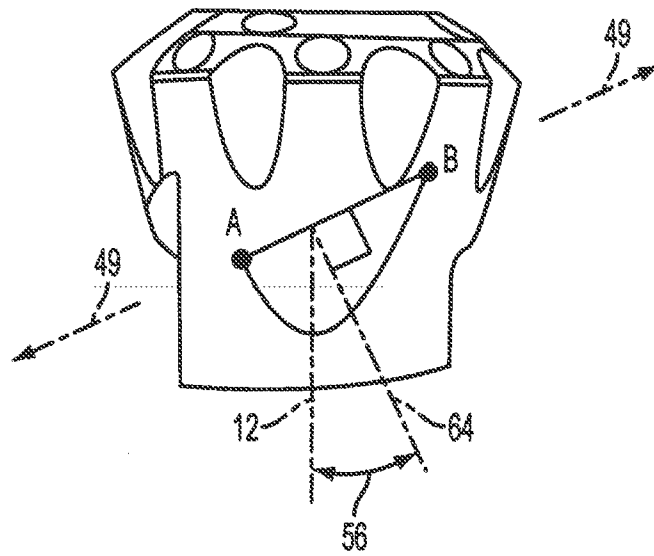

FIG. 1B

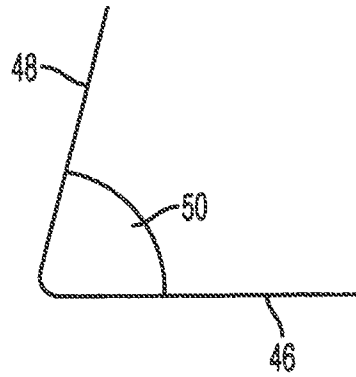

FIG. 1C

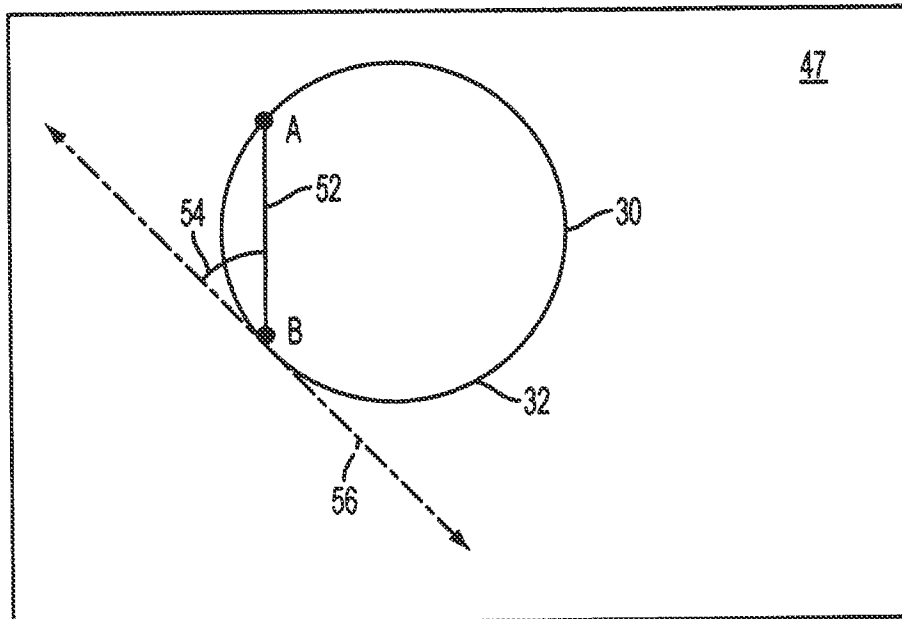

FIG. 1D

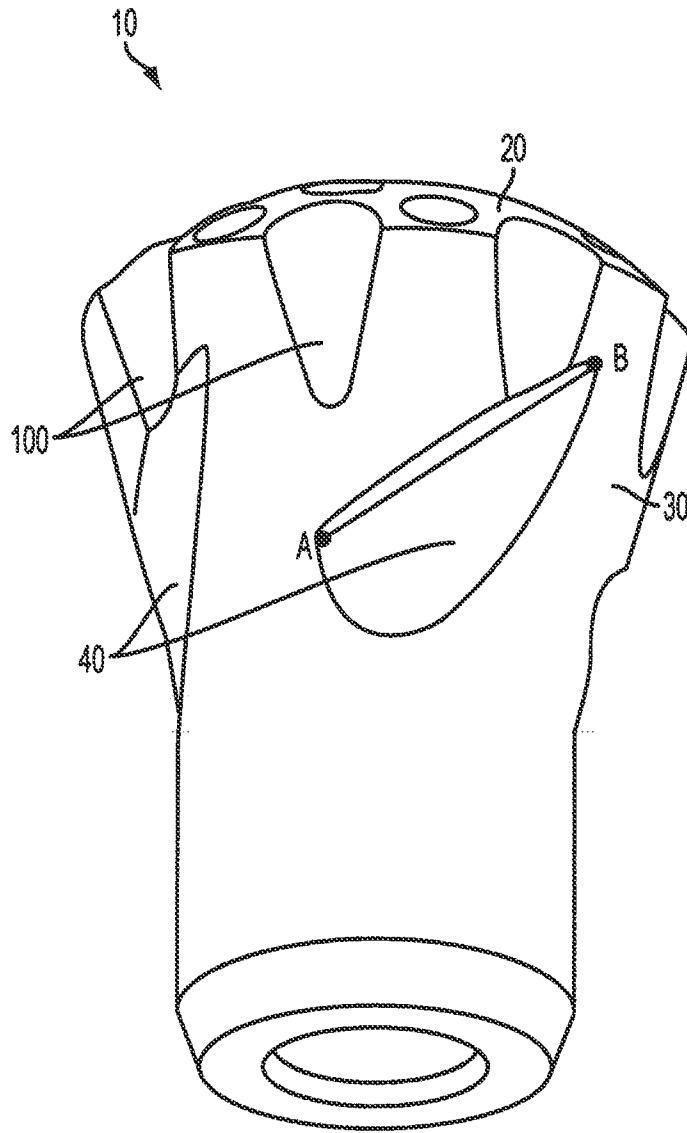

FIG. 2

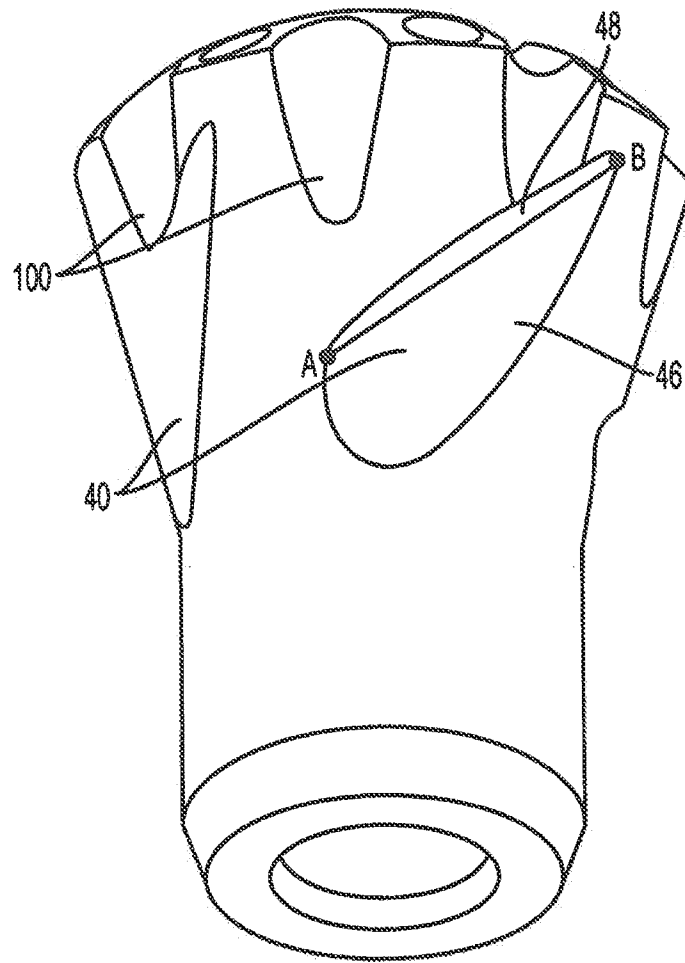

FIG. 3A

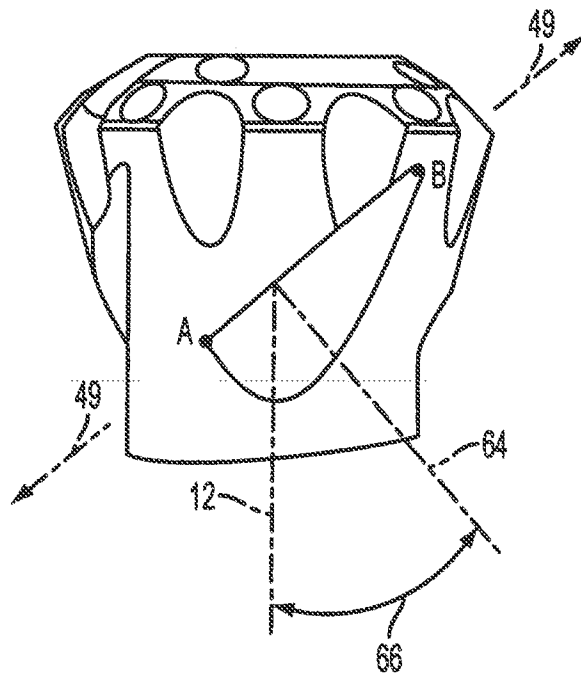

FIG. 3B

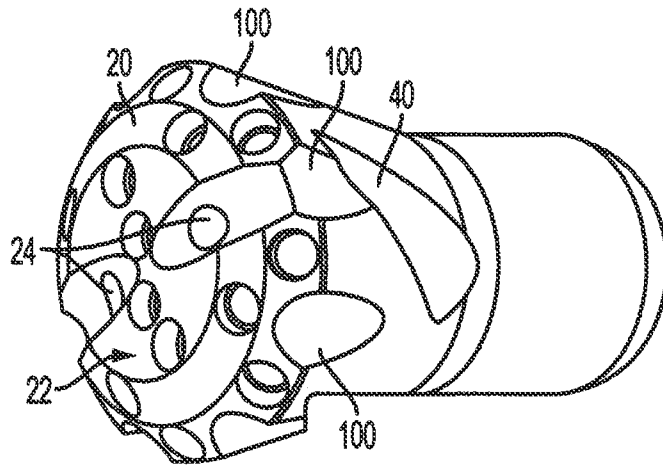

FIG. 4A

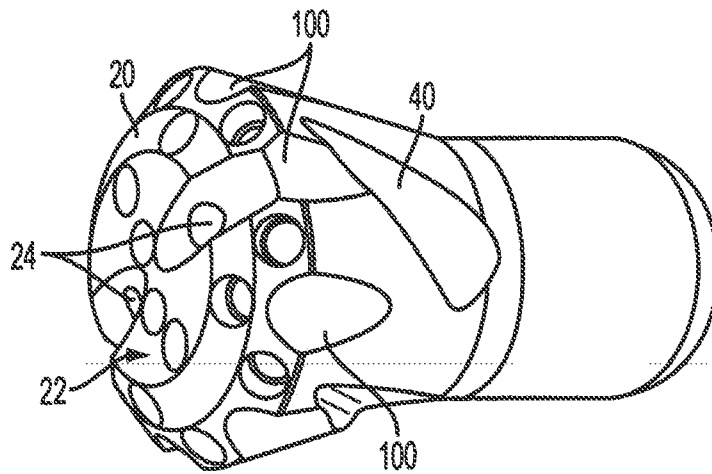

FIG. 4B

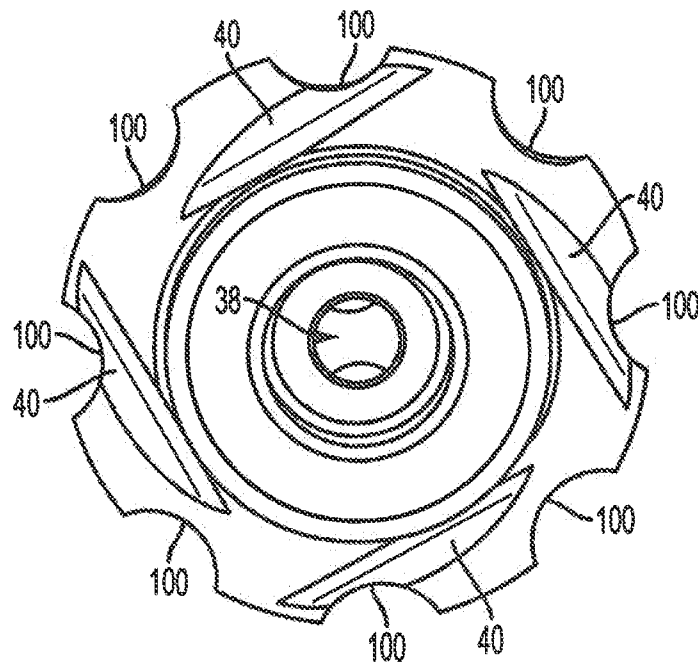

FIG. 5A

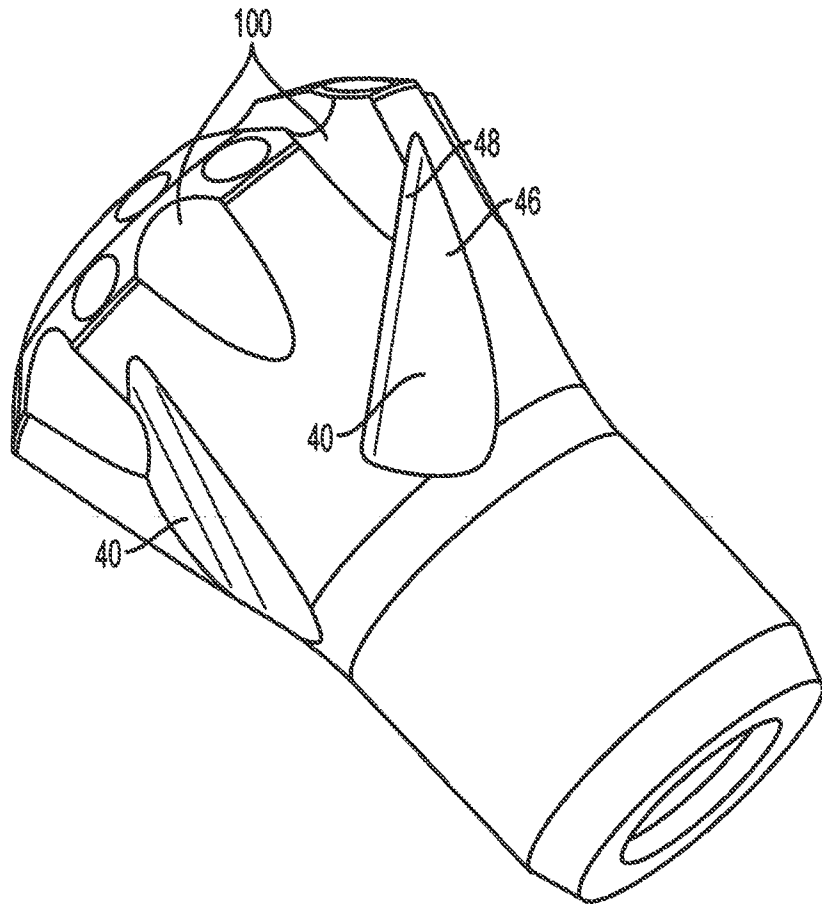

FIG. 5B

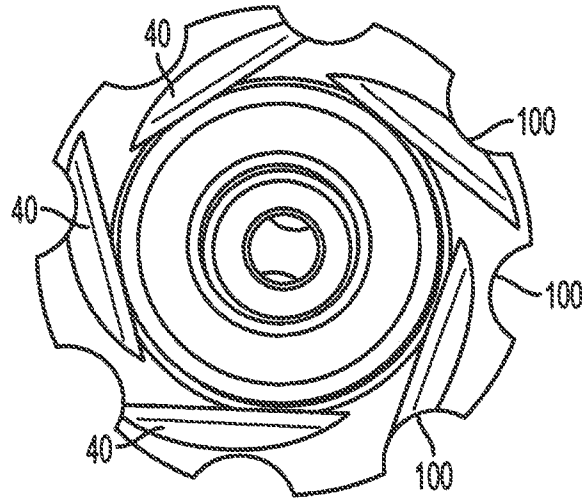

FIG. 5C

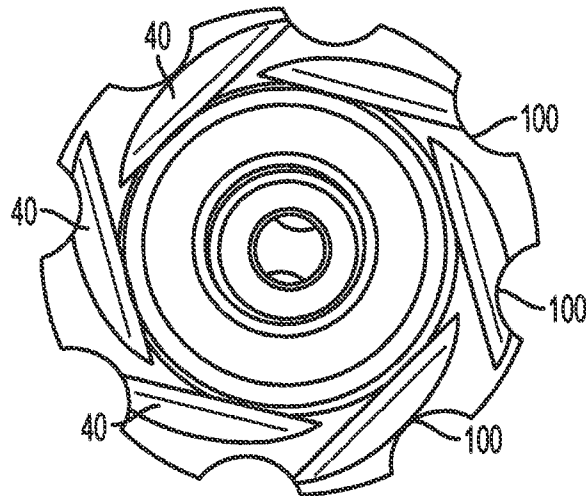

FIG. 5D

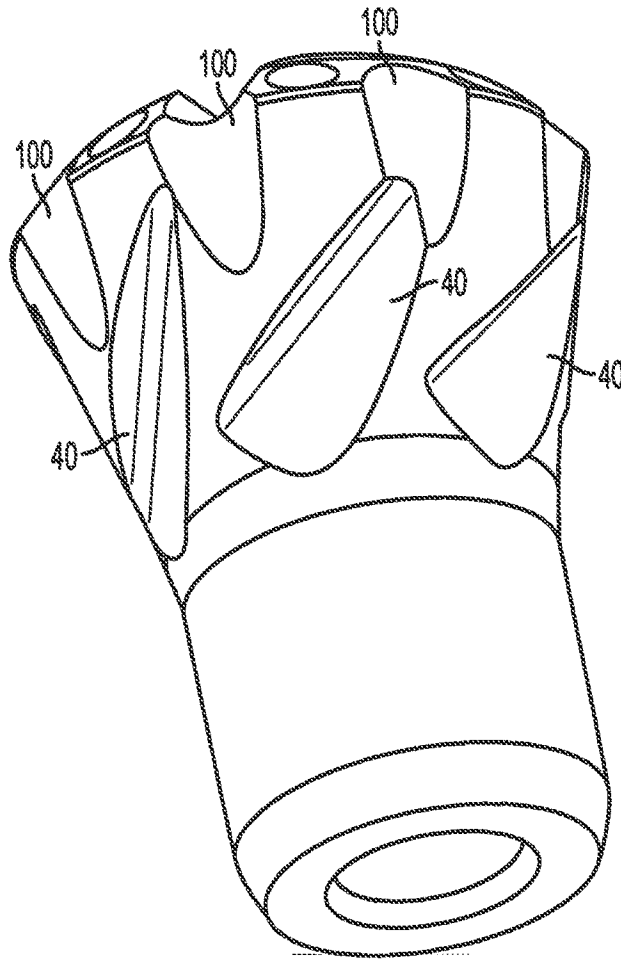

FIG. 5E

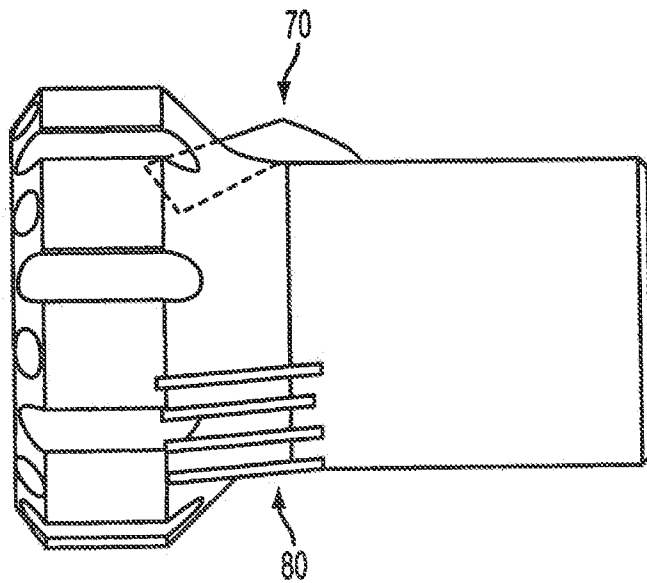

FIG. 6

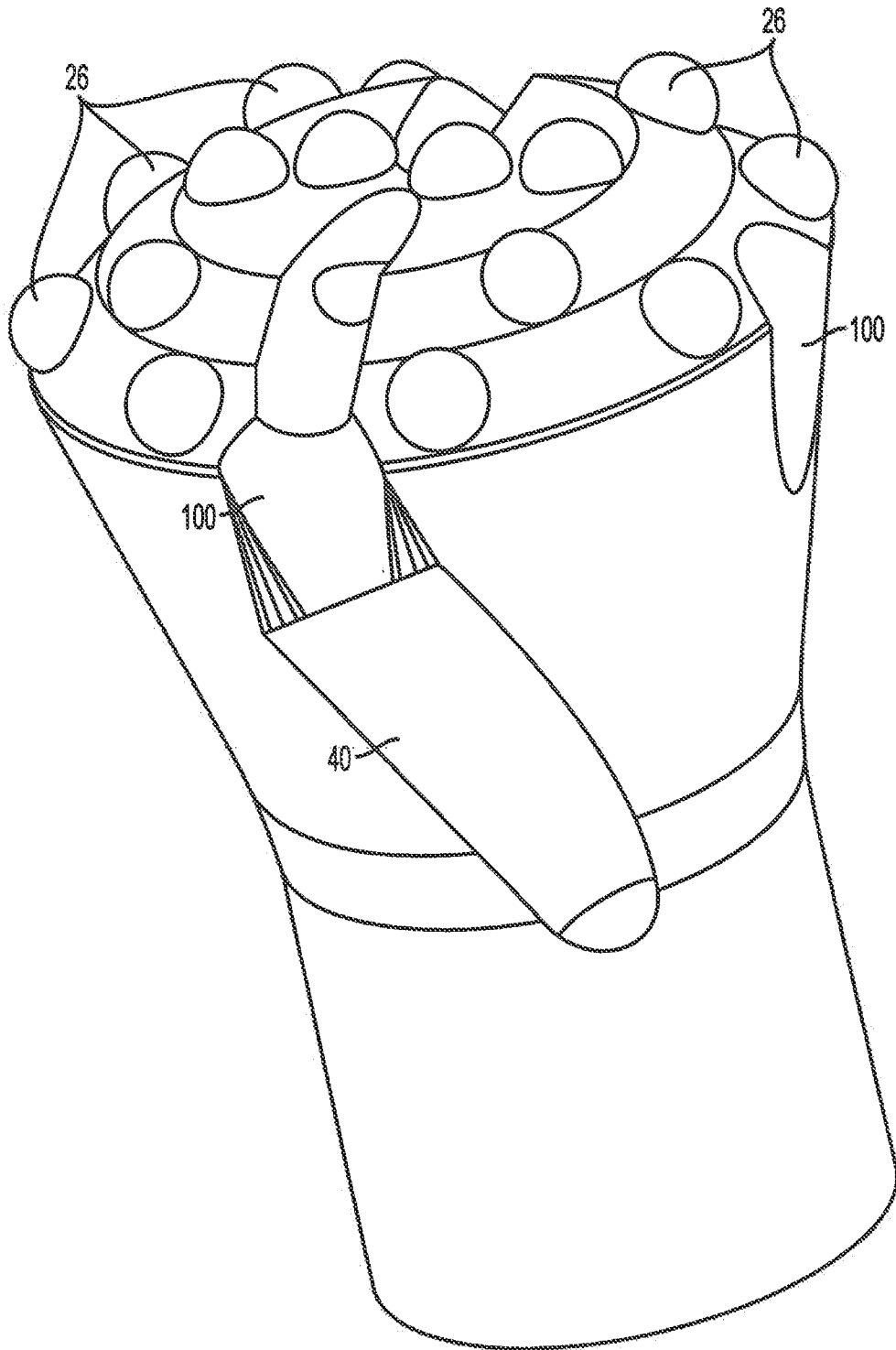

FIG. 7

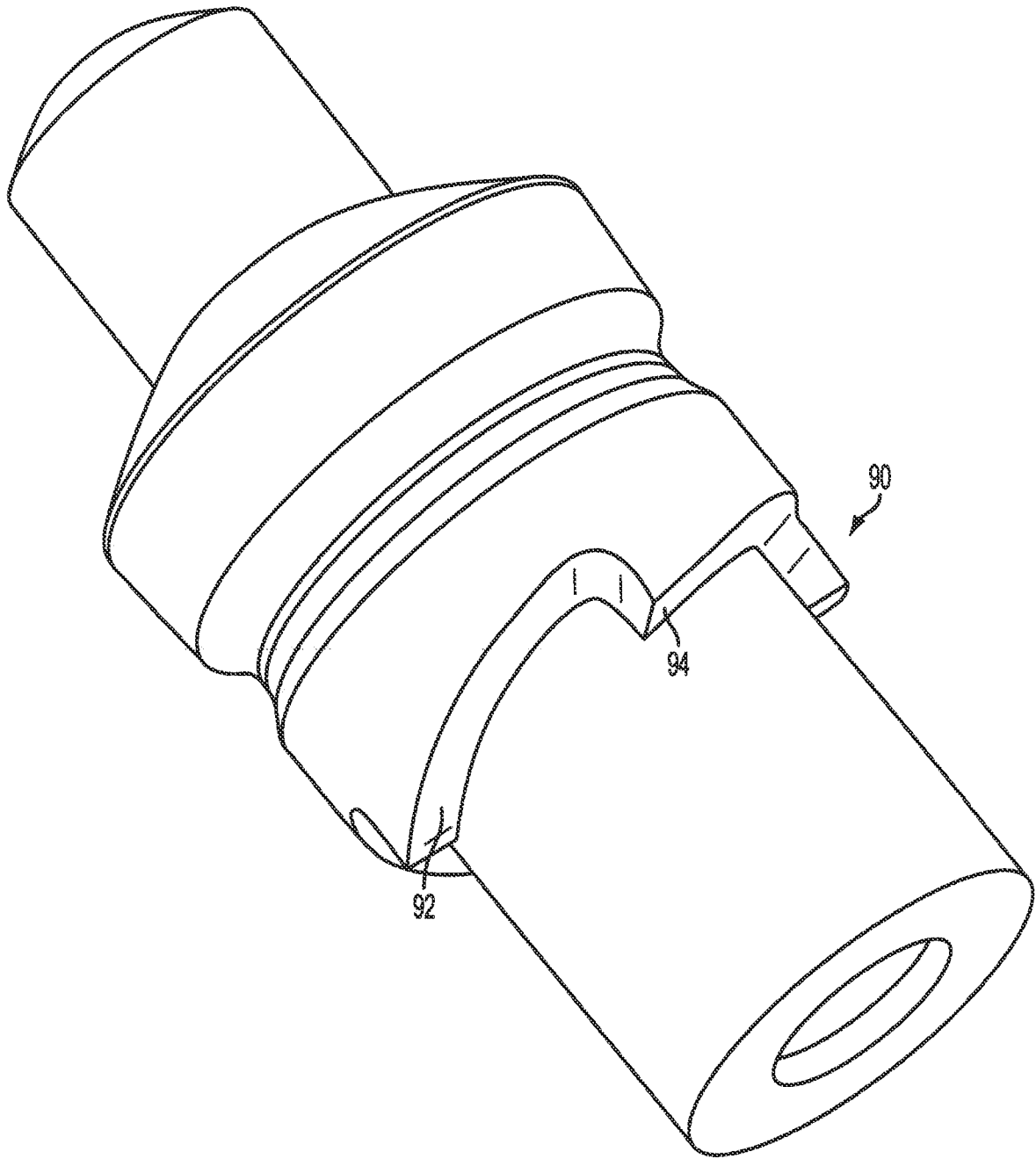

FIG. 8

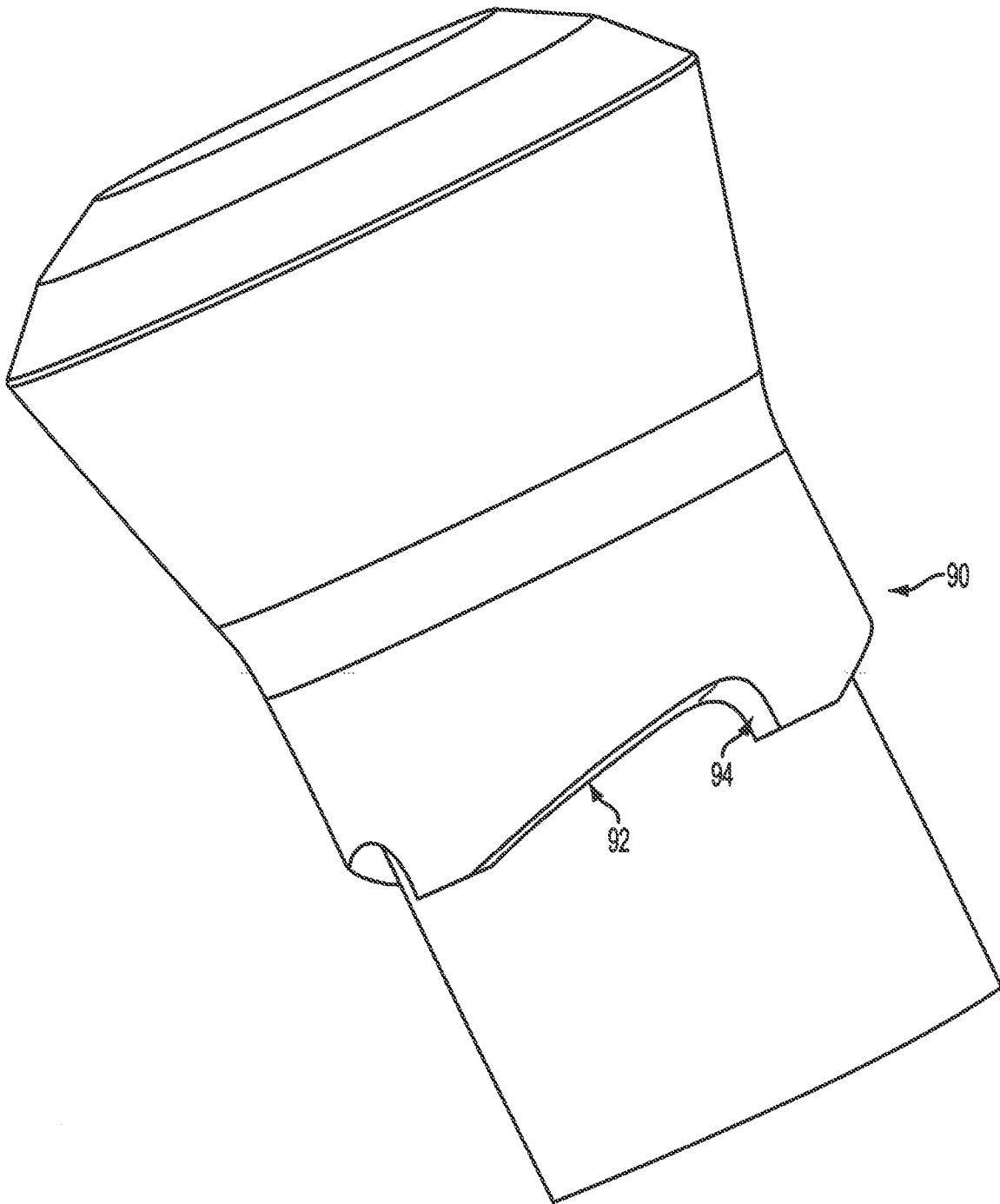

FIG. 9A

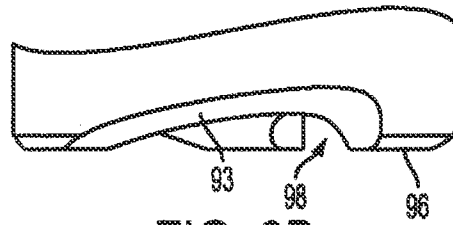

FIG. 9B

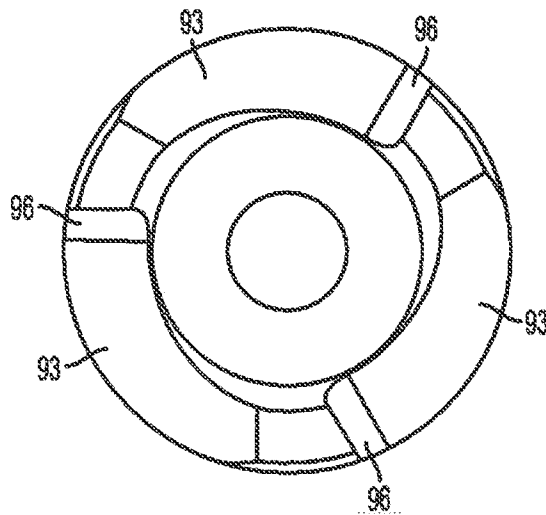

FIG. 9C

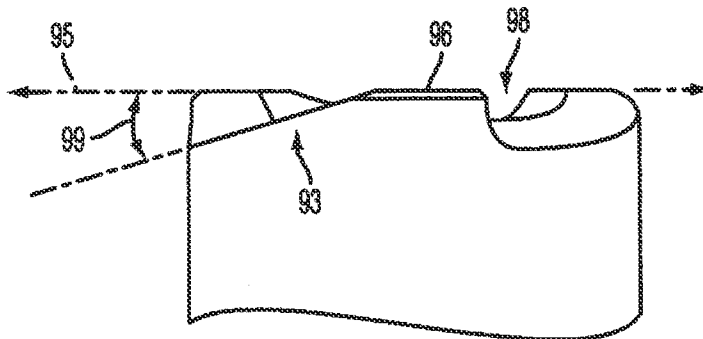

FIG. 9D

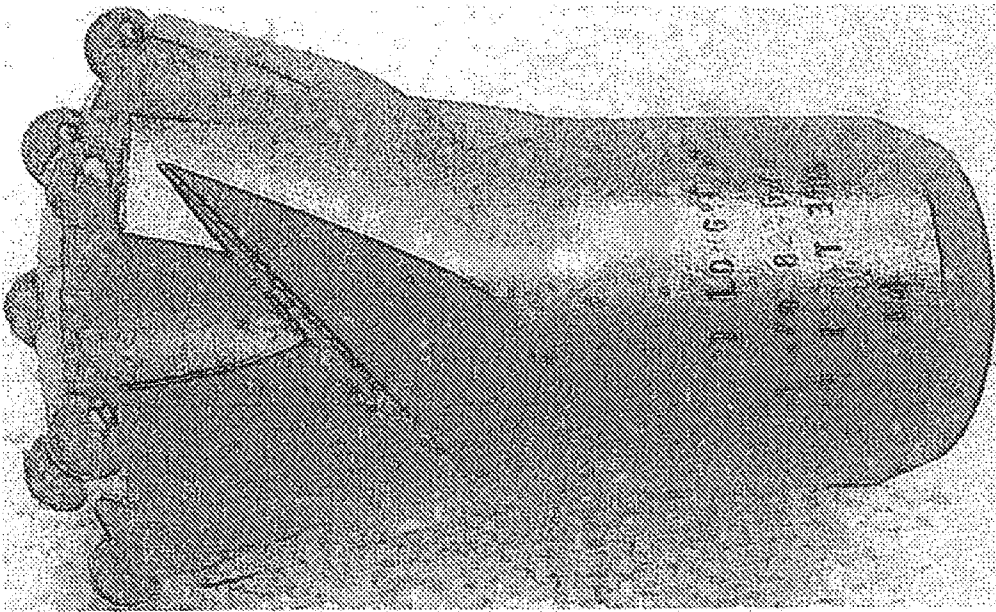

FIG. 10A

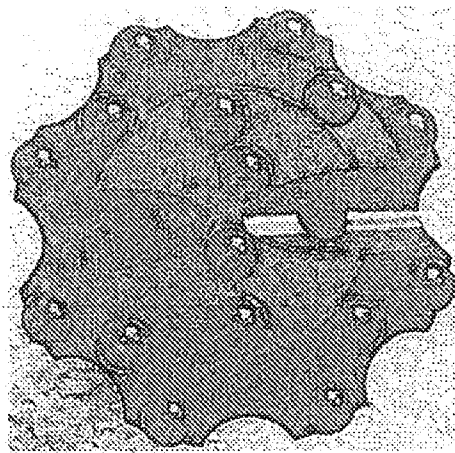

FIG. 10B



FIG. 11A

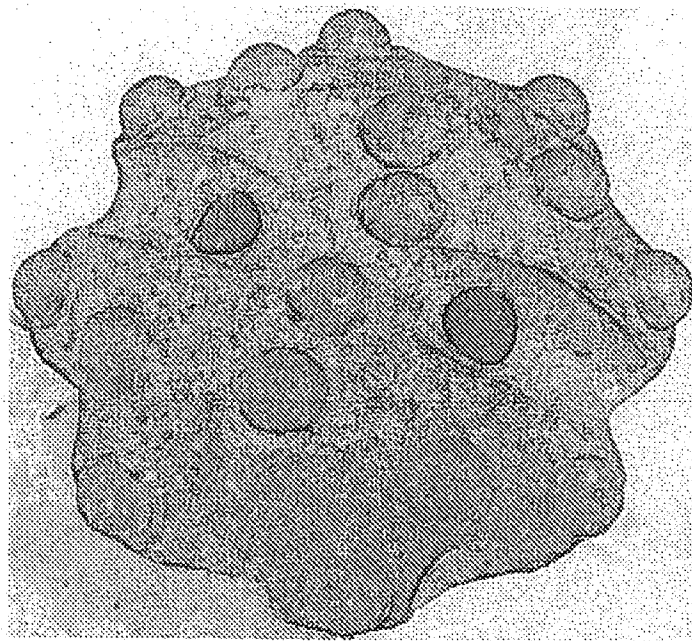

FIG. 11B

A. CLASSIFICATION OF SUBJECT MATTER**E21B 10/42(2006.01)i, E21B 10/43(2006.01)i, E21B 10/62(2006.01)i**

According to International Patent Classification (IPC) or to both national classification and IPC

B. FIELDS SEARCHED

Minimum documentation searched (classification system followed by classification symbols)

E21B 10/42; E21B 7/00; E21B 10/36; E21B 10/48; E21B 10/38; E21B 10/60; E21B 10/02; E21B 10/43; E21B 10/62

Documentation searched other than minimum documentation to the extent that such documents are included in the fields searched

Korean utility models and applications for utility models

Japanese utility models and applications for utility models

Electronic data base consulted during the international search (name of data base and, where practicable, search terms used)

eKOMPASS(KIPO internal) & Keywords:drill bit, flute, flushing channel, flushing medium, and angle

C. DOCUMENTS CONSIDERED TO BE RELEVANT

Category*	Citation of document, with indication, where appropriate, of the relevant passages	Relevant to claim No.
X	WO 2012-036849 A2 (LONGYEAR TM. INC.) 22 March 2012 See page 2, lines 1-8, page 11, line 3 - page 17, line 2, page 22, line 14 - page 23, line 25, and figures 1-2, 4-5.	1,3-23
Y		2
Y	WO 2004-104362 A1 (SHELL INTERNATIONALE RESEARCH MAATSCHAPPIJ B.V. et al.) 02 December 2004 See page 7, line 32 - page 8, line 3 and figure 1.	2
A	EP 0269400 A2 (REED TOOL COMPANY LIMITED) 01 June 1988 See column 2, line 23 - column 3, line 39 and figure 1.	1-23
A	EP 0874127 A2 (CAMCO INTERNATIONAL (UK) LIMITED) 28 October 1998 See column 4, line 53 - column 5, line 50 and figure 1.	1-23
A	US 2012-0325558 A1 (LUNDBERG et al.) 27 December 2012 See paragraphs [0041]-[0045] and figures 1-5.	1-23

 Further documents are listed in the continuation of Box C. See patent family annex.

* Special categories of cited documents:

"A" document defining the general state of the art which is not considered to be of particular relevance

"E" earlier application or patent but published on or after the international filing date

"L" document which may throw doubts on priority claim(s) or which is cited to establish the publication date of another citation or other special reason (as specified)

"O" document referring to an oral disclosure, use, exhibition or other means

"P" document published prior to the international filing date but later than the priority date claimed

"T" later document published after the international filing date or priority date and not in conflict with the application but cited to understand the principle or theory underlying the invention

"X" document of particular relevance; the claimed invention cannot be considered novel or cannot be considered to involve an inventive step when the document is taken alone

"Y" document of particular relevance; the claimed invention cannot be considered to involve an inventive step when the document is combined with one or more other such documents, such combination being obvious to a person skilled in the art

"&" document member of the same patent family

Date of the actual completion of the international search

08 October 2014 (08.10.2014)

Date of mailing of the international search report

08 October 2014 (08.10.2014)

Name and mailing address of the ISA/KR

International Application Division
Korean Intellectual Property Office
189 Cheongsu-ro, Seo-gu, Daejeon Metropolitan City, 302-701,
Republic of Korea

Facsimile No. +82-42-472-7140

Authorized officer

LEE, Jong Kyung

Telephone No. +82-42-481-3360

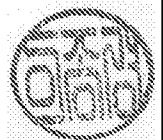

INTERNATIONAL SEARCH REPORT

Information on patent family members

International application No.

PCT/US2014/042760

Patent document cited in search report	Publication date	Patent family member(s)	Publication date
WO 2012-036849 A2	22/03/2012	AU 2011-302487 A1 CA 2808594 A1 CN 103097642 A EP 2616624 A2 PE 12792012 A1 US 2012-0061146 A1 WO 2012-036849 A3	28/02/2013 22/03/2012 08/05/2013 24/07/2013 08/10/2012 15/03/2012 28/06/2012
WO 2004-104362 A1	02/12/2004	AR 044551 A1 AT 347019 T BR PI0410536 A CA 2526249 A1 CN 100458097 C CN 1795318 A CO 5630007 A2 DE 602004003493 D1 DE 602004003493 T2 EG 23869 A EP 1627130 A1 EP 1627130 B1 NO 20056154 A RU 2005140560 A RU 2332553 C2 US 2007-0039761 A1 US 7455126 B2	21/09/2005 15/12/2006 20/06/2006 02/12/2004 04/02/2009 28/06/2006 28/04/2006 11/01/2007 20/09/2007 26/11/2007 22/02/2006 29/11/2006 17/02/2006 10/07/2006 27/08/2008 22/02/2007 25/11/2008
EP 0269400 A2	01/06/1988	EP 0269400 A3	16/08/1989
EP 0874127 A2	28/10/1998	EP 0874127 A3 GB 2325014 A GB 2325014 B GB 2359838 A GB 9708022 D0 GB 9808135 D0 US 6062325 A	02/08/2000 11/11/1998 19/12/2001 05/09/2001 11/06/1997 17/06/1998 16/05/2000
US 2012-0325558 A1	27/12/2012	AU 2011-224885 A1 CA 2791303 A1 CN 102791953 A EP 2369127 A1 KR 10-2013-0007563 A RU 2012142827 A WO 2011-112137 A1	13/09/2012 15/09/2011 21/11/2012 28/09/2011 18/01/2013 20/04/2014 15/09/2011