

July 20, 1954

E. P. BELL
SELF-WRINGING MOP

2,683,887

Filed March 13, 1950

3 Sheets-Sheet 1

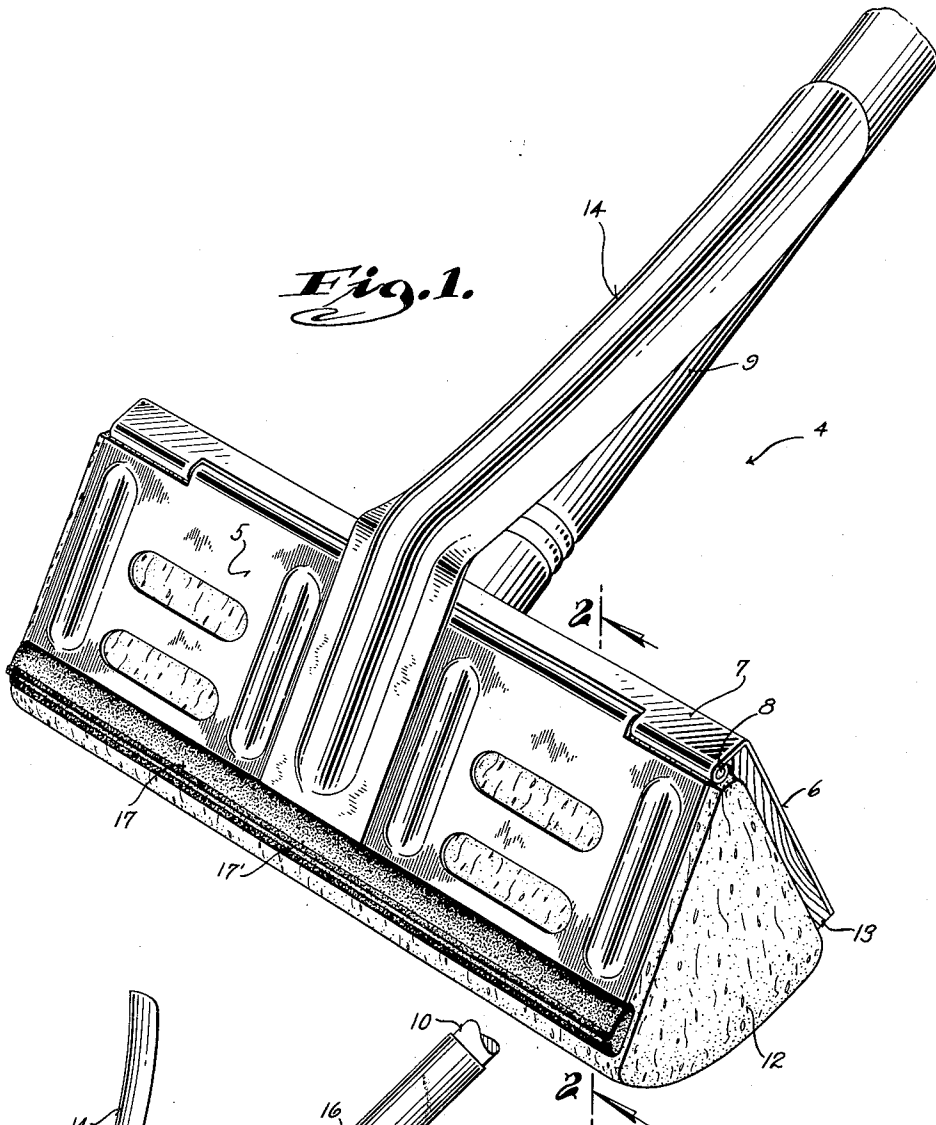

Fig. 1.

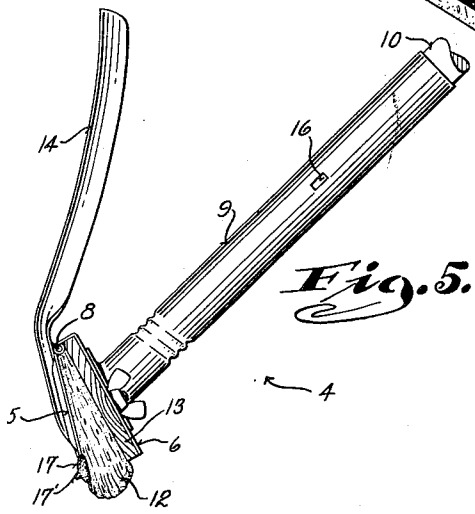

Fig. 5.

Inventor
Edwin Paul Bell
By Irving Milton Jones
attorney

July 20, 1954

E. P. BELL
SELF-WRINGING MOP

2,683,887

Filed March 13, 1950

3 Sheets-Sheet 2

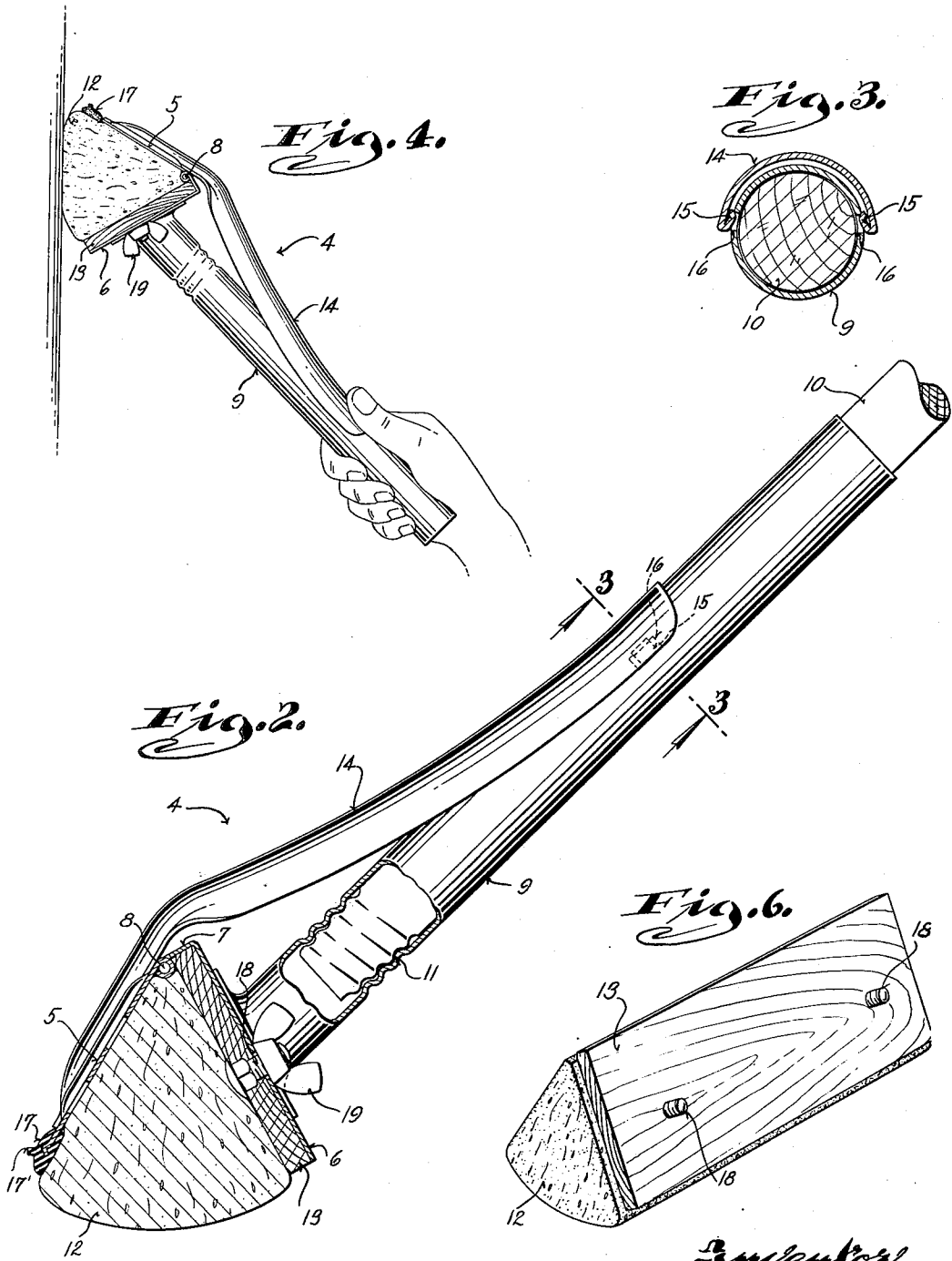

Inventor
Edwin Paul Bell
By *William Jones*
Attorney

July 20, 1954

E. P. BELL
SELF-WRINGING MOP

2,683,887

Filed March 13, 1950

3 Sheets-Sheet 3

Fig. 7.

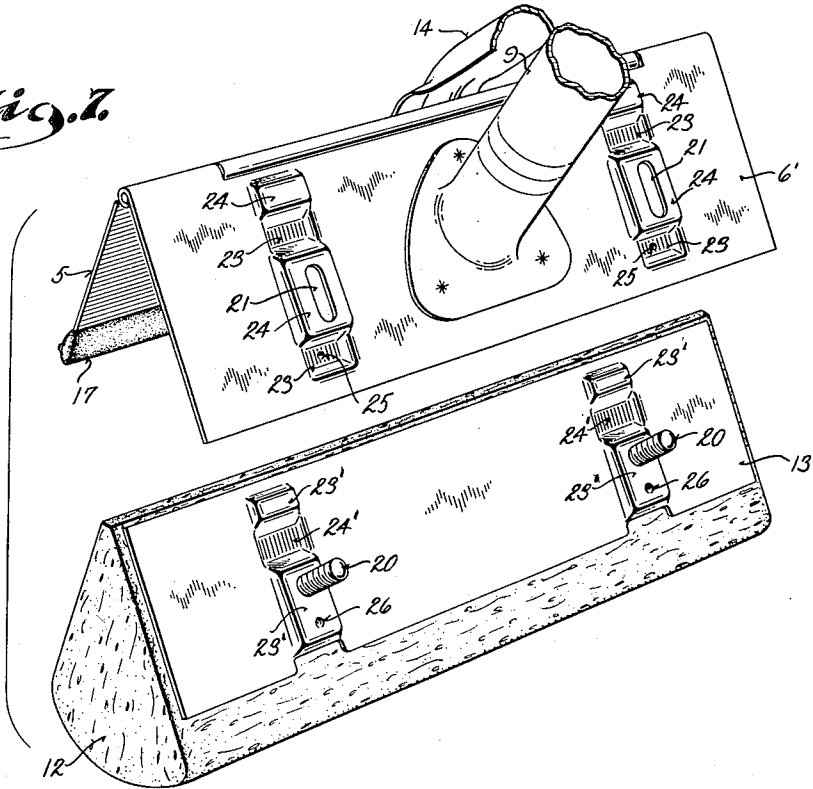

Fig. 8.

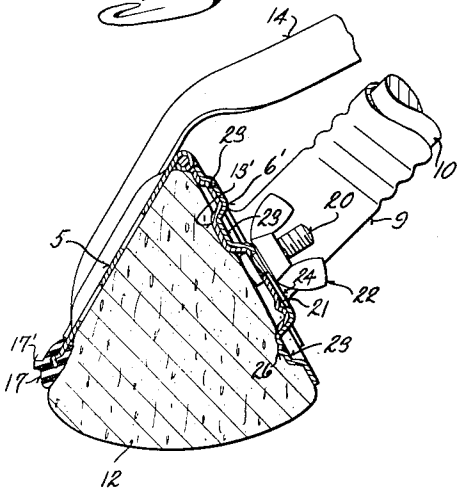
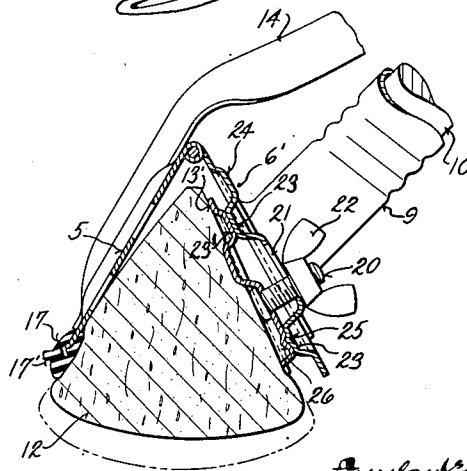

Fig. 9.



Inventor
Edwin Paul Bell
By *John William Jones*
Attorney

UNITED STATES PATENT OFFICE

2,683,887

SELF-WRINGING MOP

Edwin Paul Bell, Oshkosh, Wis., assignor of one-fourth to Ira M. Jones, Milwaukee, Wis.

Application March 13, 1950, Serial No. 149,360

5 Claims. (Cl. 15—119)

1

This invention relates to mops and refers more particularly to a mop in which the swab consists of a block-like sponge suitably secured to a head fixed to the lower end of a handle. The sponge in such mops is ordinarily made of a synthetic cellulose material which is highly absorbent and easily compressed to expel liquid therefrom.

The chief purpose of this invention is to provide a mop of this type in which the compression of the sponge to express liquid therefrom may be effected in a practical and convenient manner. In a broad sense this objective is not new. Many attempts have been made in recent years to produce a mop having a "built-in" wringing feature. The Canadian Patent No. 459,142 issued August 23, 1949, to O-Cedar of Canada Limited is an example of such past efforts.

However, all prior attempts to incorporate the so-called self-wringing feature in such mops have been objectionable for one reason or another. In many cases the arrangement was such that the mop had to be held in an unnatural and awkward position during the wringing, with the result that there was danger of having the water squirted out onto the operator; in some the squeezing or wringing pressure was applied to the bottom of the sponge so that dirt and lint accumulated by the sponge would be held there; and in others the sponge was not readily renewable and no provision was made to compensate for wear by projecting the sponge farther from its holder as its working surface was worn off.

In recognition of these and other disadvantages of previous mops of this type the present invention has as one of its objects to provide a new and improved manner of squeezing or compressing the sponge which is so designed and arranged that it allows the mop to be held in its normal natural position while it is being wrung out.

Another object of this invention is to provide a mop in which the wringing pressure is applied to the sponge in such a way that the dirt picked up thereby is flushed out as the sponge is squeezed, so that the mop may be said to be self-cleaning.

Another object of this invention is to provide a mop of the character described in which replacement of the sponge is a simple matter readily accomplished in a few seconds.

Another object of this invention is to provide a mop in which the sponge is substantially triangular in cross section and is supported between front and back jaw plates hingedly connected at

2

their top edges and normally held in an open spread-apart relation defining an acute angle to accommodate the sponge therebetween and at the same time provide support therefor as the mop is worked back and forth across the floor.

Another object of this invention is to mount the sponge upon the back jaw of the mop in a way which permits the sponge to be adjusted farther toward the lower edges of the jaws to project the same therefrom notwithstanding reduction in its thickness due to wear, and at the same time bring the sponge forward to retain its engagement with the front jaw despite the fact that when so adjusted the sponge no longer fills the space between the jaws.

Still another object of this invention is to mount the sponge without compressing any part thereof so that its entire mass is available to absorb liquid.

With the above and other objects in view, which will appear as the description proceeds, this invention resides in the novel construction, combination and arrangement of parts substantially as hereinafter described and more particularly defined by the appended claims, it being understood that such changes in the precise embodiment of the hereindisclosed invention may be made as come within the scope of the claims.

The accompanying drawings illustrate two complete examples of the physical embodiments of the invention constructed according to the best modes so far devised for the practical application of the principles thereof, and in which:

Figure 1 is a perspective view of a mop constructed in accordance with this invention;

Figure 2 is a cross sectional view through the mop shown in Figure 1 on the plane of the line 2—2, a part of the mop handle being broken away;

Figure 3 is a detail cross sectional view on the plane of the line 3—3 of Figure 2;

Figure 4 is a side view of the mop to show how the same may be used on walls and windows;

Figure 5 is a side view of the mop, showing the way in which its sponge is squeezed or compressed;

Figure 6 is a perspective view of the sponge element and the mounting plate therefor;

Figure 7 is a perspective view with parts broken away of a modified embodiment of the invention which incorporates the novel adjustable mounting for the sponge, the hinged jaw members and sponge with its mounting plate being shown in disassembled relation;

Figure 8 is a cross sectional view of the struc-

3

ture shown in Figure 7, but with the parts assembled and the sponge in its upper position of adjustment; and

Figure 9 is a view similar to Figure 8, but showing the sponge in its lower position of adjustment.

Referring now particularly to the accompanying drawings, the numeral 4 generally designates the head of the mop which comprises a front jaw 5 and a back jaw 6. The upper edges of the jaws are hingedly connected as at 8 and each jaw is a substantially rectangular plate suitably stamped from sheet metal. The front jaw preferably has a number of apertures and is stiffened by embossed transverse ribs, as clearly shown in Figure 1.

The rear jaw 6 has a tubular metal handle 9 fixed thereto and extending rearwardly and upwardly therefrom. This handle is long enough to enable the mop to be held in one hand as shown in Figure 4 for use on walls and windows, and for normal floor use is adapted to have a handle extension 10 secured therein as by a threaded connection 11 which may be near the base of the handle 9 as shown. With the threaded connection so located maximum rigidity is obtained for the handle extension; on the other hand if the threaded connection is nearer the outer end of the handle 9, the extension 10 may be shorter.

The swab of the mop consists of a body 12 of compressible bibulous material and preferably is formed of a synthetic cellulosic sponge. The body 12, which hereinafter will be referred to as a sponge, is triangular in cross section to fit the space between the jaws and is removably mounted upon the inner face of the back jaw 6 by means of a backing plate 13. In the embodiment of the invention shown in Figures 1 to 6, inclusive, this backing plate is of wood but in the modification shown in Figures 7 to 9, inclusive, is stamped of metal. In each instance the backing plate overlies one side of the sponge and has the sponge adhered thereto. Also, in each case the sponge projects slightly beyond the ends of the backing plate and jaws.

Where the wooden backing plate is used, as in the construction shown in Figures 1 to 6, inclusive, the back jaw 6 has its upper edge portion flanged as at 7 so that the front face of the backing plate to which the sponge is adhered is substantially radial to the axis of the hinge. Hence, the surfaces between which the sponge is positioned define an acute angle between them and the sponge is of such size as to fill this angular space completely when the jaws are fully open.

A lever arm 14 preferably stamped of sheet metal is welded or otherwise fixed to the front jaw 5 and extends upwardly and rearwardly across the hinge 8 in line with the handle 9 to collide therewith and limit the spreading of the jaws and thereby define their open positions. The lever arm 14 also provides the means by which the jaws may be closed onto each other to squeeze and compress the sponge therebetween, as shown in Figure 5. Attention is directed to the fact that the arrangement is such that the squeezing action may be accomplished with the mop held in its normal natural position, and further that during the compression of the sponge dirt therein will be flushed downwardly and outwardly as the water and liquid is expressed from the sponge.

Though the front jaw may be held in its outwardly swung or open position by the sponge

4

itself it is preferably releasably latched in this position and for this purpose the upper end of the lever arm 14 has detents 15 at opposite sides thereof to snap into recesses 16 in the handle 9. By so "locking" the front jaw in position its lower edge which has a rubber bumper strip 17 secured thereto may be used as a scraper to loosen stubborn dirt, it being understood that the mop is turned over when the rubber bumper strip is to be used as a scraper.

The strip 17 is preferably molded so that it may embrace the ends of the jaw as well as its lower edge, and to enable the mop to be used as a squeegee a ridge 17' projects from the front of and extends for the full length of the strip 17.

The sponge mounted on its backing plate 13 is releasably secured to the back jaw 6 by clamping screws 18 and wing nuts 19. While this manner of mounting the sponge makes the same readily replaceable it affords no adjustment of its position on the back jaw and consequently as soon as its lower projecting portion becomes worn to the point where the sponge does not protrude a sufficient distance from the lower edges of the jaws it must be replaced. However, with the construction shown in Figures 7 to 9, inclusive, the sponge is not only readily replaceable but is also adjustable downward, or more specifically, radially away from the hinge axis to project its lower portion from the lower edges of the jaws, notwithstanding the fact that it has been worn.

To this end the sheet metal backing plate 13' is somewhat narrower than the flat side of the sponge to which it is adhered and fastening screws 20 are fixed to and project rearwardly from the backing plate 13' to project through elongated holes 21 in the back jaw 6' to have wing nuts 22 threaded thereon. Making the backing plate 13' narrower than the side of the sponge to which it is adhered does not detract from the support afforded this side of the sponge for when the sponge is in place in its normal position of adjustment as shown in Figure 8 the lower edge of the back jaw 6' supports the same.

The elongated shape and transverse disposition of the holes 21 enable the backing plate and, of course, the sponge fixed thereto to be adjusted radially outwardly of the hinge axis from a normal position, shown in Figure 8, wherein the sponge extends all the way to the hinge and fills the angular space between the jaws to a lowered position of adjustment shown in Figure 9. However, it will be appreciated that if the sponge were merely slid down across the inner face of the back jaw 6' it would move away from the front jaw 5 and therefore would not be adequately supported.

To overcome this disadvantage means are provided for holding the backing plate spaced from the back jaw 6' when it is adjusted to its lowered position shown in Figure 9. The means provided for this purpose comprises interengaging or interfitting pads and depressions 23 and 24, respectively, pressed into the back jaw 6' and 23' and 24' on the backing plate 13'.

In the normal position of adjustment shown in Figure 8, which is used when the sponge is new, the pads and depressions interengage or nest one within the other to thus enable the backing plate 13' to lie flat against the back jaw 6'. But when the sponge is moved to its lower position of adjustment, shown in Figure 9, the pads seat one upon the other to thereby hold the sponge spaced away from the back jaw and against

5

the front jaw. Displacement of the sponge from this position of adjustment is prevented not only by the tightening of the wing nuts 22 but by the interengagement of detents 25 and 26 on the back jaw and backing plate, respectively.

Attention is also directed to the fact that by having the pads and indentations or depressions arranged in the manner illustrated, that is, extending to opposite sides of the planes of the back jaw and backing plate, the height of the pads is materially reduced and a far more practical construction results. It is also to be noted that the tops of the pads are inclined with respect to the planes of the back jaw and backing plate with the pad portions farthest from the hinge axis highest. This feature assures proper disposition of the sponge in its lower position of adjustment.

From the foregoing description taken in connection with the accompanying drawings, it will be readily apparent that this invention not only provides a very useful and practical mop by reason of the extensibility and ease of replacement of its sponge element, but one which is light, and easily handled and in which the wringing out of the sponge element may be accomplished with minimum effort.

What I claim as my invention is:

1. In a mop having a pair of hingedly connected complementary jaws normally defining an acute angle between them, and a sponge triangular in cross section in and substantially fitting the space between the opened jaws, means mounting the sponge on the inner face of one of the jaws, said means comprising: a backing plate to which the sponge is fixed; screws fixed to the backing plate and projecting through openings in said designated jaw, said openings accommodating the screws at different distances from the hinge axis of the jaws so as to provide for adjustment of the backing plate to positions spaced different distances from the hinge axis and thereby enable the sponge to be projected beyond the outer edges of the jaws remote from their hinge connection regardless of wear upon the sponge; clamping nuts threaded on the screws to hold the backing plate in a first position against the jaw upon which it is mounted with the backing plate spaced a maximum distance from the other jaw; and cooperating spacing means on the backing plate and said designated jaw having surfaces engaged when the backing plate is shifted outwardly of the hinge axis to project the sponge farther beyond the outer edges of the jaws for holding the backing plate in a second position on its jaw displaced a distance from the first position of the backing plate in the direction of the other jaw and in which second position the sponge is engaged with said other jaw.

2. The mop defined in claim 1 wherein said cooperating spacing means comprises recesses on the designated jaw spaced apart radially with respect to the hinge axis of the jaws; pads on the backing plate projecting beyond the plane of the inner face of said designated jaw and into the recesses thereof to allow the backing plate to lie flat against the inner surface of the jaw in the first position of the backing plate and the sponge thereon, and said pads being engageable with inner surfaces of said designated jaw when the backing plate is moved radially outwardly of the hinge axis, to thereby hold the backing plate in its second position with the sponge thereon engaged with the other jaw notwith-

6

standing the radially projected disposition of the sponge.

3. A mop comprising: a pair of elongated relatively flat complementary front and back jaw members hingedly connected along one longitudinal edge thereof to have their opposing inner surfaces substantially radial to the hinge axis; a handle fixed to and projecting from the back jaw member; a lever arm fixed to the front jaw member and extending therefrom across the hinge connection and in line with the handle to collide therewith and thereby limit separation of the jaw members beyond positions at which they define an acute angle having its apex substantially at the axis of said hinge connection, said lever arm being movable away from the handle to swing the jaw members toward one another so as to expel water from a sponge element therebetween; a sponge element substantially triangular in cross section substantially filling the space between said members wholly outwardly of the hinge axis and extending below the outer free edges of the jaw members remote from the hinge axis thereof; a mounting plate for the sponge element and to which the sponge element is secured; and means releasably securing the mounting plate to the inner face of one of said jaw members.

4. A mop comprising: a pair of elongated complementary jaw members hingedly connected along one longitudinal edge thereof and having flat inner surfaces substantially radial to the hinge axis; means limiting opening movement of the jaw members to preclude their swinging beyond positions at which said inner surfaces thereof define an acute angle having its apex substantially at the axis of said hinge connection; a sponge substantially triangular in cross section and fitting in the space between the opened jaws with a portion thereof extending beyond the outer free edges of the jaws remote from the hinge axis; a backing plate to which the sponge is secured; adjustable means for securing the backing plate to one of the jaw members, said adjustable means enabling the sponge to be shifted a defined distance radially outwardly away from the hinge axis and also bodily away from the jaw member upon which it is mounted; means for holding the backing plate spaced from said inner surface of the jaw member upon which it is mounted and the sponge against the other jaw member when said backing plate is shifted radially outwardly from the hinge axis comprising complementary pads on the backing plate and the jaw member to which it is secured, said pads interengaging in one position of adjustment of the backing plate and being seated upon one another in another position of adjustment of the backing plate; a handle fixed to and projecting from one of the jaw members; and a lever arm fixed to the other jaw member and extending alongside the handle when the jaw members are spread apart their maximum distance, movement of the lever arm away from the handle forcing the jaw members together to squeeze the sponge therebetween.

5. The mop of claim 3, further characterized by the fact that said means securing the mounting plate to said one jaw member enable the mounting plate to be adjustably held at different distances from the hinge axis to compensate for wear on the portion of the sponge element which extends below the jaw members.

2,083,887

7

References Cited in the file of this patent

UNITED STATES PATENTS

Number	Name	Date
210,953	McCarthy -----	Dec. 17, 1878
1,539,857	Martin -----	June 2, 1925
2,165,319	Vaughn -----	July 11, 1939
2,196,837	Rader -----	Apr. 9, 1940
2,210,967	Vaughn -----	Aug. 13, 1940

Number
2,384,029
2,515,403
2,525,603

8

Name	Date
Hawkins -----	Sept. 4, 1945
Greenleaf et al. ----	July 18, 1950
Kautenberg -----	Oct. 10, 1950

FOREIGN PATENTS

Number	Country	Date
453,292	Italy -----	Nov. 23, 1949
844,035	France -----	July 18, 1939