



- (51) International Patent Classification:
G01T 1/16 (2006.01) *G01T 1/161* (2006.01)
- (21) International Application Number:
PCT/EP2017/068231
- (22) International Filing Date:
19 July 2017 (19.07.2017)
- (25) Filing Language: English
- (26) Publication Language: English
- (30) Priority Data:
16180176.6 19 July 2016 (19.07.2016) EP
- (71) Applicant: UNIVERSITÄT BASEL [CH/CH]; Vizerektorat Forschung Petersgraben 35, 4001 Basel (CH).
- (72) Inventors: CATTIN, Philippe C.; Muelligerstrasse 16M, 5210 Windisch (CH). HAERLE, Stephan; Stefanstrasse 38, 4106 Therwil (CH).
- (74) Agent: LATSCHA, Silvan; Latscha Schöllhorn Partner AG Austrasse 24, 4051 Basel (CH).
- (81) Designated States (unless otherwise indicated, for every kind of national protection available): AE, AG, AL, AM, AO, AT, AU, AZ, BA, BB, BG, BH, BN, BR, BW, BY, BZ, CA, CH, CL, CN, CO, CR, CU, CZ, DE, DJ, DK, DM, DO, DZ, EC, EE, EG, ES, FI, GB, GD, GE, GH, GM, GT, HN, HR, HU, ID, IL, IN, IR, IS, JO, JP, KE, KG, KH, KN, KP, KR, KW, KZ, LA, LC, LK, LR, LS, LU, LY, MA, MD, ME, MG, MK, MN, MW, MX, MY, MZ, NA, NG, NI, NO, NZ, OM, PA, PE, PG, PH, PL, PT, QA, RO, RS, RU, RW, SA, SC, SD, SE, SG, SK, SL, SM, ST, SV, SY, TH, TJ, TM, TN, TR, TT, TZ, UA, UG, US, UZ, VC, VN, ZA, ZM, ZW.
- (84) Designated States (unless otherwise indicated, for every kind of regional protection available): ARIPO (BW, GH, GM, KE, LR, LS, MW, MZ, NA, RW, SD, SL, ST, SZ, TZ, UG, ZM, ZW), Eurasian (AM, AZ, BY, KG, KZ, RU, TJ, TM), European (AL, AT, BE, BG, CH, CY, CZ, DE, DK, EE, ES, FI, FR, GB, GR, HR, HU, IE, IS, IT, LT, LU, LV, MC, MK, MT, NL, NO, PL, PT, RO, RS, SE, SI, SK, SM,

(54) Title: IMAGING DEVICE AND METHOD OF VISUALIZING A SENTINEL LYMPH NODE

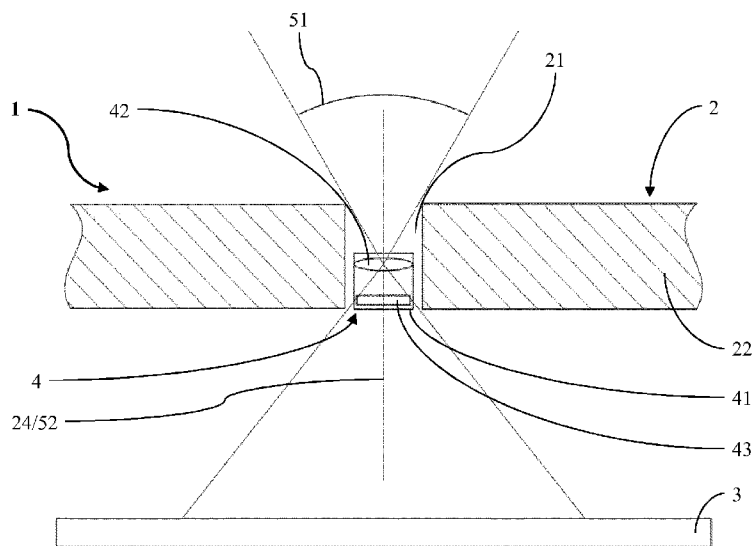

Fig. 1

(57) Abstract: An imaging device (1) comprises a collimator (2), a radiation detector (3) and a visible light camera (4). The collimator has a passage which on one side ends in a pinhole (21). The radiation detector (3) is arranged adjacent to a side of the passage opposite to the pinhole (21) of the collimator (2). The visible light camera (4) is arranged at the pinhole (21) of the collimator (2). Such an imaging device allows for efficiently visualizing a radioactive tracer in a human or animal body. Particularly, it can be used for efficiently and accurately visualizing a sentinel lymph node of a human or animal patient.



TR), OAPI (BF, BJ, CF, CG, CI, CM, GA, GN, GQ, GW,
KM, ML, MR, NE, SN, TD, TG).

Declarations under Rule 4.17:

- *as to applicant's entitlement to apply for and be granted a patent (Rule 4.17(ii))*

Published:

- *with international search report (Art. 21(3))*

5 DESCRIPTIONTitle

IMAGING DEVICE AND METHOD OF VISUALIZING A SENTINEL LYMPH NODE

10 Technical Field

[0001] The present invention relates to an imaging device and more particularly to a method of visualizing a sentinel lymph node. Such imaging device and method can be used for visualizing a radioactive tracer in a human or animal body or for visualizing a sentinel lymph node of a human or animal patient, respectively.

15

Background Art

[0002] In many medical treatments or applications tracers are used for identifying or visualizing items or processes within human or animal bodies. Such tracers often are radioactive substances which are, e.g. with a syringe, administered to the human or
20 animal patient and which have properties to suitably behave in the body of the patient such that conclusions related to the medical conditions of the patient can be drawn. Since the substances are radioactive they can be located from outside the body by appropriate means.

[0003] For example, for treating tumor patients particularly having tumors in the area
25 of the face, neck or breast it often is important to analyze a sentinel node. Sentinels are the first lymph nodes in the lymphatic systems after the tumor. I.e., sentinels are the lymph nodes neighboring the tumors. Analyzing the sentinel allows for concluding if and to what extent lymph nodes have to be removed for preventing the tumor to propagate.

[0004] For locating the tracers within the bodies it is known to use gamma cameras.
30 Such cameras usually have a collimator and a gamma photon detector. The collimator is arranged adjacent to the body where the tracer is suspected. Gamma photons which are emitted by the tracer and which permeate the body are provided through the

collimator and are detected by the gamma photon detector. The gamma photon detector provides signals which precisely correspond to the emission of gamma photons by the tracer.

5 [0005] Since such gamma cameras only detect gamma photons an image generated does not allow for a convenient evaluation without elaborate post-processing. For precisely and reliably locating the tracer often the signals or images provided by gamma cameras are combined with visual light images. Thereby, regular visual light cameras are used for catching an image of the situation and the image or signals provided by the gamma camera are merged into the visual light image.

10 [0006] However, usually combining the signals or data provided by the two different cameras is quite cumbersome and may also result in comparably unprecise images. For example, since bodies typically are three dimensional structures one visual light camera is not sufficient to provide appropriate information about the situation. Furthermore, visual light cameras usually have a widening field of view. Thus, information gathered
15 from a periphery of the field of view is distorted in relation to the information gathered from the center of the field of view. Thus, in order to obtain a sufficiently precise localization of the tracer the images provided by the plural visual light cameras and the gamma cameras have to be evaluated and processed in a comparably complicated manner. This leads in many cases to unsatisfying results which do not allow a
20 sufficiently precise detection or to requiring expensive equipment and cumbersome application.

[0007] Therefore, there is a need for a device or process allowing a precise and reliable detection of a tracer in a human or animal body in an efficient way and, particularly, allowing an efficient and precise detection of a sentinel node.

25

Disclosure of the Invention

[0008] According to the invention this need is settled by an imaging device as it is defined by the features of independent claim 1, and by a method as it is defined by the features of independent claim 12. Preferred embodiments are subject of the dependent
30 claims.

[0009] In particular, the invention deals with an imaging device for visualizing a radioactive tracer in a human or animal body. The imaging device comprises a collimator, a radiation detector and a visible light camera. The collimator has a passage which on one side ends in a pinhole. It can be made of a material which is suitable to shield radiation, particularly radioactive radiation, gamma radiation or gamma photons. For example, it can be made of lead.

[0010] The passage of the collimator can have the same dimension as the pinhole such that the pinhole simply is one of the two axial ends of the passage. It can also have a larger diameter than the pinhole such that the pinhole forms a narrowed entrance of the passage. The pinhole can form an opening of one side of the passage.

[0011] The radiation detector is arranged adjacent to a side of the passage opposite to the pinhole of the collimator. In this connection, the term "opposite" can relate to a position of the radiation detector being vis-à-vis the pinhole such that the radiation detector is facing the pinhole via the passage. Thus, the pinhole can form an opening of the passage at one side opposite to the radiation detector.

[0012] The radiation can be radioactive radiation and particularly gamma radiation. In such embodiments, the radiation detector can be a gamma photon detector. The collimator and the radiation detector of the imaging device can form or be comprised by a gamma camera or collimator gamma camera.

[0013] The visible light camera is arranged at the pinhole of the collimator. In this connection the term "at the pinhole" can relate to the visible light camera being located in the pinhole or close to it. The term "close" in this context can relate to being within a distance which not larger than the diameter of the pinhole.

[0014] By positioning the visible light camera at the pinhole the imaging device can provide an image or data of the visible situation together with detected radiation. Thereby, the collimator and radiation combination can provide a scope of information which is similar or identical to the scope of the visual light camera. Due to the proximity of the visual light camera and the passage the visual light camera and the collimator can have the same or essentially same optical center and aligned optical axis. This allows for efficiently providing a comparably high precision, particularly for comparably close objects.

- [0015] The imaging device allows for efficiently providing an augmented reality imaging at a comparably high precision. Particularly, the images or data provided by the visual light camera and the radiation detector can be overlaid in a comparably easy manner. For, example the imaging device can be positioned in proximity of a human or animal body to which a tracer is provided and which might be appropriately prepared. The imaging device then generates an image of the body by its visual light camera which is augmented by an image of the radiation detector. Like this, no 3D camera structure such as plural appropriately positioned visual light cameras is necessary. This allows for making the set up particularly easy and efficient.
- 10 [0016] Thus, the imaging device according to the invention allows for a precise and reliable detection of a tracer in a human or animal body in an efficient way and, also, for an efficient and precise detection of a sentinel.
- [0017] Preferably, the visible light camera is a micro-camera or a nano-camera. Such micro-cameras or nano-cameras can be similar or identical to endoscopic cameras. Endoscopic cameras have been proved to be sufficiently accurate and robust such that they can allow for an efficient implementation of the imaging device. The micro- or nano-cameras can be dimensioned with a base area of about 1-1.5 mm x 1-1.5 mm. Thus, such cameras can be appropriately precise and small to be used within the imaging device.
- 15 [0018] In preferred embodiments, the visible light camera is arranged in a plane defined by a diameter of the pinhole of the collimator. Like this, the visible light camera can be placed in the pinhole or on the pinhole. Like this, the image or data generated by the visual light camera and the radiation detector can be efficiently and precisely correlated which allows for efficiently combining them.
- 20 [0019] The visible light camera preferably completely or essentially covers the pinhole of the collimator. In this context, the term "essentially covers" can relate to an arrangement of the visual light camera substantially closing the pinhole. Thereby, around the visible light camera there can still be some gaps but the major portion of the pinhole is closed. In such an arrangement the radiation can pass the visible light camera and corresponding visible light can be caught by it.
- 25
30

[0020] Preferably, the passage has a longitudinal axis and the visible light camera has an optical axis which is essentially or completely identical to the longitudinal axis of the passage. Like this, it can efficiently be achieved that the collimator and radiation combination has the same alignment as the visual light camera. This allows for efficiently providing an accurate augmented image.

[0021] The collimator and the radiation detector preferably together form part of a radiation camera, wherein imaging properties of the visible light camera do essentially correspond to imaging properties of the radiation camera. Thereby, the radiation camera can particularly be a gamma camera or a collimator gamma camera. Like this, image and data gathered or generated by the visual light camera and the radiation camera can efficiently be combined in an accurate manner.

[0022] Thereby, a field of view of the visible light camera preferably is essentially identical or bigger than a field of view of the radiation camera. This allows for providing a particular high consistency and accuracy of the images and data generated by the radiation and visual light cameras.

[0023] In a preferred embodiment, the imaging device further comprises a processing unit which is connected to the visible light camera and to the radiation detector such that signals generated by the visible light camera and by the radiation detector are transferrable to the processing unit wherein the processing unit is adapted to overlay the signals of the visible light camera and the radiation detector and to generate an augmented image. The signals generated can particularly be images, a stream of images or similar data capable for generating a visual representation. The term "overlay" in this connection can relate to adding the signals or information generated by one of the visible light camera and the radiation detector to the other one of the same. The augmented image can be an image of the real visual situation enriched with information which is not visible or identifiable. This allows for an efficient evaluation of the information gathered.

[0024] Preferably, the collimator has at least one further passage which on one side ends in an at least one further pinhole and which comprises at least one further visible light camera arranged at the at least one further pinhole of the collimator. More particular, the pinhole and the at least one further pinhole preferably form a systematic array together with the visible light camera and the at least one further visible light

camera. Such a multi camera or camera array imaging device allows for providing a larger area covered by the imaging device. Thereby, the images or augmented images generated by the single visible light camera and collimator/detector combinations can be combined or put together to a larger image covering a comparably large area of the body or object to be monitored. For example, the single augmented images can form pixel like sub-images of the final image combining the sub-images.

[0025] An additional advantage of such a multi pinhole and passage collimator or multi camera imaging device can be that the different pinholes and visible light cameras may capture the targets or lymph nodes from different angles. Due to these different angles the lymph nodes can also be mapped for each visible light camera on different locations. This parallax effect can be readily used to estimate the distance of the sentinel node from the collimator. It even might allow for differentiating two lymph nodes that are behind each other and as such indistinguishable from each other with any other imaging device.

[0026] In embodiments of imaging devices having plural pinholes, passages and visible light cameras the visible light cameras and the pinholes can lie in a plane. Thereby, the planes of the visual light cameras and of the pinholes may be identical or different such as parallel to each other. Alternatively, the visible light cameras and the pinholes can be arranged in a curve or other non-planar arrangement. In some applications, such curved or non-planar arrangement can allow for an improved evaluation or gathering of information in 3-dimensions. The visual light cameras and the pinholes can also be arranged in a random fashion on the plane.

[0027] In a preferred embodiment, the collimator is made of a material essentially impervious for a radioactive radiation or for gamma photons. Such material allows for sidewardly shielding the radiation and efficiently aligning it. Like this, a precise radiation image can be generated.

[0028] Another aspect of the invention relates to a method of visualizing a sentinel lymph node of a human or animal patient. The method comprises the steps of: administering a radioactive tracer to the patient; positioning an imaging device according to any one of the preceding claims in proximity of the patient; overlaying signals of a visible light camera of the imaging device and a radiation detector of the imaging device; and generating an augmented image from the overlaid signals of the

visible light camera of the imaging device and the radiation detector of the imaging device. Thereby, the imaging device preferably is positioned to be directed to a face, neck or breast of the patient.

[0029] Such a method allows for implementing effects and benefits described above in connection with the imaging device in a sentinel analysis application. This allows for efficiently evaluating the conditions of the body with respect to a tumor.

Brief Description of the Drawings

[0030] The imaging device and the method according to the invention are described in more detail hereinbelow by way of an exemplary embodiment and with reference to the attached drawings, in which:

Fig. 1 shows a schematic cross sectional view of a section of an embodiment of an imaging device according to the invention;

Fig. 2 shows a schematic perspective view of the imaging device of Fig. 1; and

Fig. 3 shows a schematic cross sectional view of a collimator and radiation detector combination of the imaging device of Fig. 1.

Description of Embodiments

[0031] In the following description, to avoid repetition in the figures and the descriptions of the various aspects and illustrative embodiments, it should be understood that many features are common to many aspects and embodiments. Omission of an aspect from a description or figure does not imply that the aspect is missing from embodiments that incorporate that aspect. Instead, the aspect may have been omitted for clarity and to avoid prolix description. In this context, the following applies to the rest of this description: If, in order to clarify the drawings, a figure contains reference signs which are not explained in the directly associated part of the description, then it is referred to previous or following description sections. Further, for reason of lucidity, if in a drawing not all features of a part are provided with reference signs it is referred to other drawings showing the same part. Like numbers in two or more figures represent the same or similar elements.

[0032] Fig. 1 shows a section of an embodiment of an imaging device 1 according to the invention. The imaging device 1 comprises a number of collimators 2, an identical number of micro-cameras 4 as visual light cameras and a gamma photon detector 3 as radiation detector. The collimators 2 are formed by a lead body 22 which is impervious for gamma photons. Each of the collimators 2 has a pinhole 21 facing the detector 3. The micro-cameras 4 have a housing 41 encasing an optics 42 and a visual light detector 43.

[0033] At each of the pinholes 21 one of the micro-cameras 4 is arranged. More specifically, each micro-camera 4 is arranged in a plane defined by a diameter of the associated pinhole 21. Thereby, the micro-camera 4 essentially covers the associated pinhole 21.

[0034] As can be seen in Fig. 2 the imaging device 1 has three rows of six collimators 2 built by the lead body 22. The collimators 2 are regularly positioned and together form an array which generates one image on the detector 3. In Fig. 3 it is shown that each collimator 2 has a passage 23 shaped by the lead body 22. The passage 23 has a longitudinal axis 24. The detector 3 is positioned adjacent to the passage 23, i.e. at the open longitudinal end side of the passage 23 opposite to the pinhole 21. The pinhole 21 forms a narrowed opening opposite the detector 3.

[0035] Turning back to Fig. 1, the micro-camera 4 has an optical axis 52 which is identical to the longitudinal axis 24 of the passage 23. The collimator 2 and the detector 3 together form part of a gamma camera. The imaging properties of the micro-camera 4 do essentially correspond to the imaging properties of the gamma camera. In particular, a field of view 51 of the micro-camera is identical to the field of view 51 of the gamma camera.

[0036] The imaging device 1 further comprises a computer as processing unit (not shown in the Figs.). The computer is connected to the micro-cameras 4 and to the detector 3. Signals generated by the micro-cameras 4 and by the detector 3 can be transferred to the computer. The computer is adapted to overlay the signals of the micro-cameras 4 and the detector 3 and to generate an augmented image out of it.

[0037] For visualizing a radioactive tracer 6 in a human or animal body, as shown in Fig. 3, the imaging device 1 is placed such that the body provided with the tracer 6 is

positioned near the pinholes 21 of the collimators 2. In particular, for visualizing a sentinel lymph node of a human or animal patient, the radioactive tracer 6 is previously administered to the human or animal patient. Then the imaging device 1 is positioned in proximity of the patient and particularly near where the tracer 6 is assumed. The imaging device 1 generates augmented images out of the overlaid signals of the micro-cameras 4 and the detector 3. The augmented images are then evaluated by a doctor or other skilled person.

[0038] This description and the accompanying drawings that illustrate aspects and embodiments of the present invention should not be taken as limiting-the claims defining the protected invention. In other words, while the invention has been illustrated and described in detail in the drawings and foregoing description, such illustration and description are to be considered illustrative or exemplary and not restrictive. Various mechanical, compositional, structural, electrical, and operational changes may be made without departing from the spirit and scope of this description and the claims. In some instances, well-known circuits, structures and techniques have not been shown in detail in order not to obscure the invention. Thus, it will be understood that changes and modifications may be made by those of ordinary skill within the scope and spirit of the following claims. In particular, the present invention covers further embodiments with any combination of features from different embodiments described above and below.

[0039] The disclosure also covers all further features shown in the Figs. individually although they may not have been described in the afore or following description. Also, single alternatives of the embodiments described in the figures and the description and single alternatives of features thereof can be disclaimed from the subject matter of the invention or from disclosed subject matter. The disclosure comprises subject matter consisting of the features defined in the claims or the exemplary embodiments as well as subject matter comprising said features.

[0040] Furthermore, in the claims the word "comprising" does not exclude other elements or steps, and the indefinite article "a" or "an" does not exclude a plurality. A single unit or step may fulfil the functions of several features recited in the claims. The mere fact that certain measures are recited in mutually different dependent claims does not indicate that a combination of these measures cannot be used to advantage. The terms "essentially", "about", "approximately" and the like in connection with an attribute or a value particularly also define exactly the attribute or exactly the value, respectively.

The term “about” in the context of a given numerate value or range refers to a value or range that is, e.g., within 20%, within 10%, within 5%, or within 2% of the given value or range. Components described as coupled or connected may be electrically or mechanically directly coupled, or they may be indirectly coupled via one or more
5 intermediate components. Any reference signs in the claims should not be construed as limiting the scope.

New International Patent Application
Universität Basel
Attorney Ref.: P5085PC00

CLAIMS

- Claim 1: Imaging device (1) for visualizing a radioactive tracer (6) in a human or animal body, comprising:
a collimator (2) having a passage (23) which on one side ends in a pinhole (21);
a radiation detector (3) being arranged adjacent to a side of the passage (23) opposite to the pinhole (21) of the collimator (2); and
a visible light camera (4) arranged at the pinhole (21) of the collimator (2).
- Claim 2: Imaging device (1) according to claim 1, wherein the visible light camera (4) is a micro-camera or a nano-camera.
- Claim 3: Imaging device (1) according to claim 1 or 2, wherein the visible light camera (4) is arranged in a plane defined by a diameter of the pinhole (21) of the collimator (2).
- Claim 4: Imaging device (1) according to any one of the preceding claims, wherein the visible light camera (4) essentially covers the pinhole (21) of the collimator (2).
- Claim 5: Imaging device (1) according to any one of the preceding claims, wherein the passage (23) has a longitudinal axis (24) and the visible light camera (4) has an optical axis (52) which is essentially identical to the longitudinal axis (24) of the passage (23).
- Claim 6: Imaging device (1) according to any one of the preceding claims, in which the collimator (2) and the radiation detector (3) together form part of a radiation camera (2, 3), wherein imaging properties of the visible light camera (4) do essentially correspond to imaging properties of the radiation camera (2, 3).

- Claim 7: Imaging device (1) according to claim 6, wherein a field of view (51) of the visible light camera (4) is essentially identical or bigger than a field of view (51) of the radiation camera (2, 3).
- Claim 8: Imaging device (1) according to any one of the preceding claims, further comprising a processing unit which is connected to the visible light camera (4) and to the radiation detector (3) such that signals generated by the visible light camera (4) and by the radiation detector (3) are transferrable to the processing unit wherein the processing unit is adapted to overlay the signals of the visible light camera (4) and the radiation detector (3) and to generate an augmented image.
- Claim 9: Imaging device (1) according to any one of the preceding claims, in which the collimator (2) has at least one further passage (23) which on one side ends in an at least one further pinhole (21) and which comprises at least one further visible light camera (4) arranged at the at least one further pinhole (21) of the collimator (2).
- Claim 10: Imaging device (1) according to claim 9, in which the pinhole (21) and the at least one further pinhole (21) form a systematic array together with the visible light camera (4) and the at least one further visible light camera (4).
- Claim 11: Imaging device (1) according to any one of the preceding claims, wherein the collimator (2) is made of a material essentially impervious for a radioactive radiation.
- Claim 12: Method of visualizing a sentinel lymph node of a human or animal patient, comprising:
- administering a radioactive tracer (6) to the patient;
 - positioning an imaging device (1) according to any one of the preceding claims in proximity of the patient;
 - overlaying signals of a visible light camera (4) of the imaging device (1) and a radiation detector (3) of the imaging device; and
 - generating an augmented image from the overlaid signals of the visible light camera (4) of the imaging device (1) and the radiation detector (3) of the imaging device (1).

Claim 13: Method according to claim 12, wherein the imaging device (1) is positioned to be directed to a face, neck or breast of the patient.

DRAWINGS

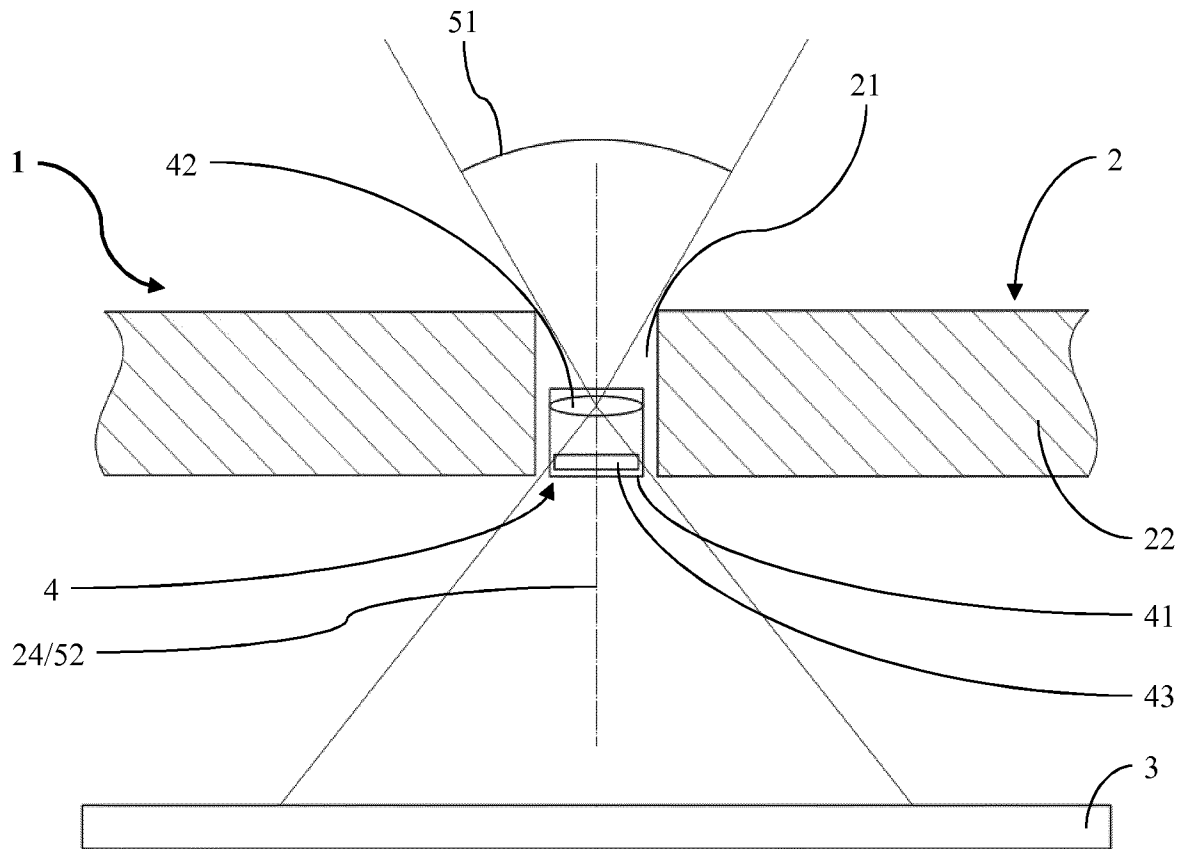

Fig. 1

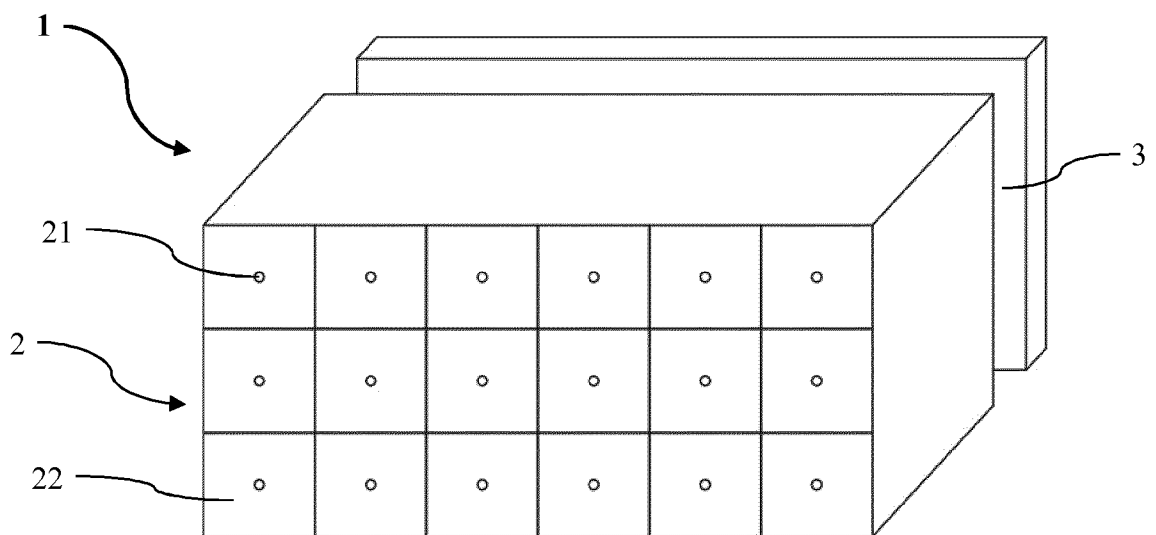

Fig. 2

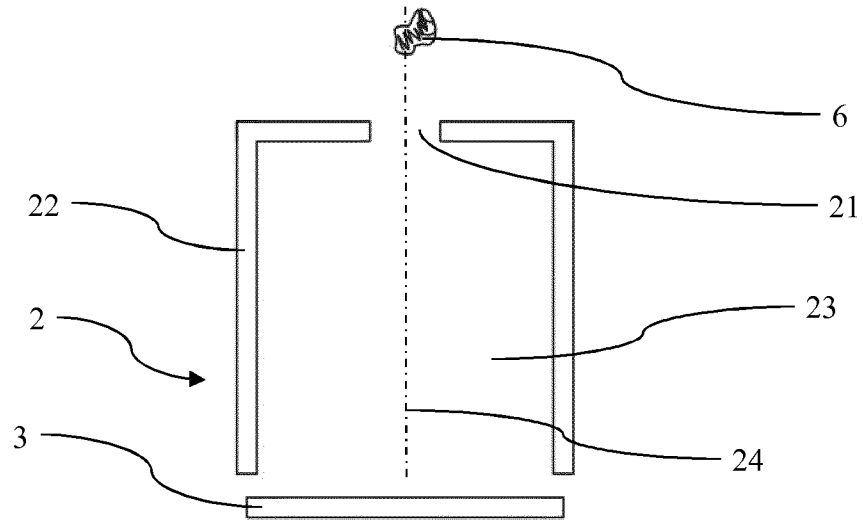

Fig. 3

INTERNATIONAL SEARCH REPORT

International application No
PCT/EP2017/068231

A. CLASSIFICATION OF SUBJECT MATTER
INV. G01T1/16 G01T1/161
ADD.
According to International Patent Classification (IPC) or to both national classification and IPC

B. FIELDS SEARCHED
Minimum documentation searched (classification system followed by classification symbols)
G01T
Documentation searched other than minimum documentation to the extent that such documents are included in the fields searched

Electronic data base consulted during the international search (name of data base and, where practicable, search terms used)
EPO-Internal, WPI Data, INSPEC, COMPENDEX

C. DOCUMENTS CONSIDERED TO BE RELEVANT

Category*	Citation of document, with indication, where appropriate, of the relevant passages	Relevant to claim No.
X	LEES J E ET AL: "A Hybrid Camera for simultaneous imaging of gamma and optical photons", JOURNAL OF INSTRUMENTATION, INSTITUTE OF PHYSICS PUBLISHING, BRISTOL, GB, vol. 7, no. 6, 18 June 2012 (2012-06-18), page P06009, XP020224898, ISSN: 1748-0221, DOI: 10.1088/1748-0221/7/06/P06009 abstract; figures page 2, paragraph 2 - page 3, paragraph 2.1 ----- -/--	1-8

Further documents are listed in the continuation of Box C.

See patent family annex.

* Special categories of cited documents :

<p>"A" document defining the general state of the art which is not considered to be of particular relevance</p> <p>"E" earlier application or patent but published on or after the international filing date</p> <p>"L" document which may throw doubts on priority claim(s) or which is cited to establish the publication date of another citation or other special reason (as specified)</p> <p>"O" document referring to an oral disclosure, use, exhibition or other means</p> <p>"P" document published prior to the international filing date but later than the priority date claimed</p>	<p>"T" later document published after the international filing date or priority date and not in conflict with the application but cited to understand the principle or theory underlying the invention</p> <p>"X" document of particular relevance; the claimed invention cannot be considered novel or cannot be considered to involve an inventive step when the document is taken alone</p> <p>"Y" document of particular relevance; the claimed invention cannot be considered to involve an inventive step when the document is combined with one or more other such documents, such combination being obvious to a person skilled in the art</p> <p>"&" document member of the same patent family</p>
---	---

Date of the actual completion of the international search 11 September 2017	Date of mailing of the international search report 21/09/2017
--	--

Name and mailing address of the ISA/ European Patent Office, P.B. 5818 Patentlaan 2 NL - 2280 HV Rijswijk Tel. (+31-70) 340-2040, Fax: (+31-70) 340-3016	Authorized officer Eberle, Katja
--	---

INTERNATIONAL SEARCH REPORT

International application No
PCT/EP2017/068231

C(Continuation). DOCUMENTS CONSIDERED TO BE RELEVANT		
Category*	Citation of document, with indication, where appropriate, of the relevant passages	Relevant to claim No.
X	<p>WO 2009/047328 A2 (DKFZ KREBSFORSCHUNGSZENTRUM [DE]; PETER JOERG [DE]) 16 April 2009 (2009-04-16) page 8, line 3 - line 23 page 10, line 14 - line 18 page 10, line 31 - line 33; figures</p> <p style="text-align: center;">-----</p>	1,4-6, 9-11
A	<p>PROFETA ANDREA CORRADO ET AL: "Augmented reality visualization in head and neck surgery: an overview of recent findings in sentinel node biopsy and future perspectives", BRITISH JOURNAL OF ORAL AND MAXILLOFACIAL SURGERY, CHURCHILL LIVINGSTONE, EDINBURGH, GB, vol. 54, no. 6, 22 January 2016 (2016-01-22), pages 694-696, XP029600448, ISSN: 0266-4356, DOI: 10.1016/J.BJOMS.2015.11.008 abstract; figures</p> <p style="text-align: center;">-----</p>	1-11

INTERNATIONAL SEARCH REPORT

International application No.
PCT/EP2017/068231

Box No. II Observations where certain claims were found unsearchable (Continuation of item 2 of first sheet)

This international search report has not been established in respect of certain claims under Article 17(2)(a) for the following reasons:

1. Claims Nos.: 12, 13
because they relate to subject matter not required to be searched by this Authority, namely:
Claim 12 relates to a treatment by surgery ("administering a radioactive tracer to the patient") and is therefore not patentable (PCT Guidelines 2016, Part III, 9.08). The same is true for claim 13 due to its dependency on claim 12.
2. Claims Nos.:
because they relate to parts of the international application that do not comply with the prescribed requirements to such an extent that no meaningful international search can be carried out, specifically:
3. Claims Nos.:
because they are dependent claims and are not drafted in accordance with the second and third sentences of Rule 6.4(a).

Box No. III Observations where unity of invention is lacking (Continuation of item 3 of first sheet)

This International Searching Authority found multiple inventions in this international application, as follows:

1. As all required additional search fees were timely paid by the applicant, this international search report covers all searchable claims.
2. As all searchable claims could be searched without effort justifying an additional fees, this Authority did not invite payment of additional fees.
3. As only some of the required additional search fees were timely paid by the applicant, this international search report covers only those claims for which fees were paid, specifically claims Nos.:
4. No required additional search fees were timely paid by the applicant. Consequently, this international search report is restricted to the invention first mentioned in the claims; it is covered by claims Nos.:

Remark on Protest

- The additional search fees were accompanied by the applicant's protest and, where applicable, the payment of a protest fee.
- The additional search fees were accompanied by the applicant's protest but the applicable protest fee was not paid within the time limit specified in the invitation.
- No protest accompanied the payment of additional search fees.

INTERNATIONAL SEARCH REPORT

Information on patent family members

International application No

PCT/EP2017/068231

Patent document cited in search report	Publication date	Patent family member(s)	Publication date
WO 2009047328	A2	16-04-2009	
		EP 2201408 A2	30-06-2010
		US 2010219348 A1	02-09-2010
		WO 2009047328 A2	16-04-2009
