

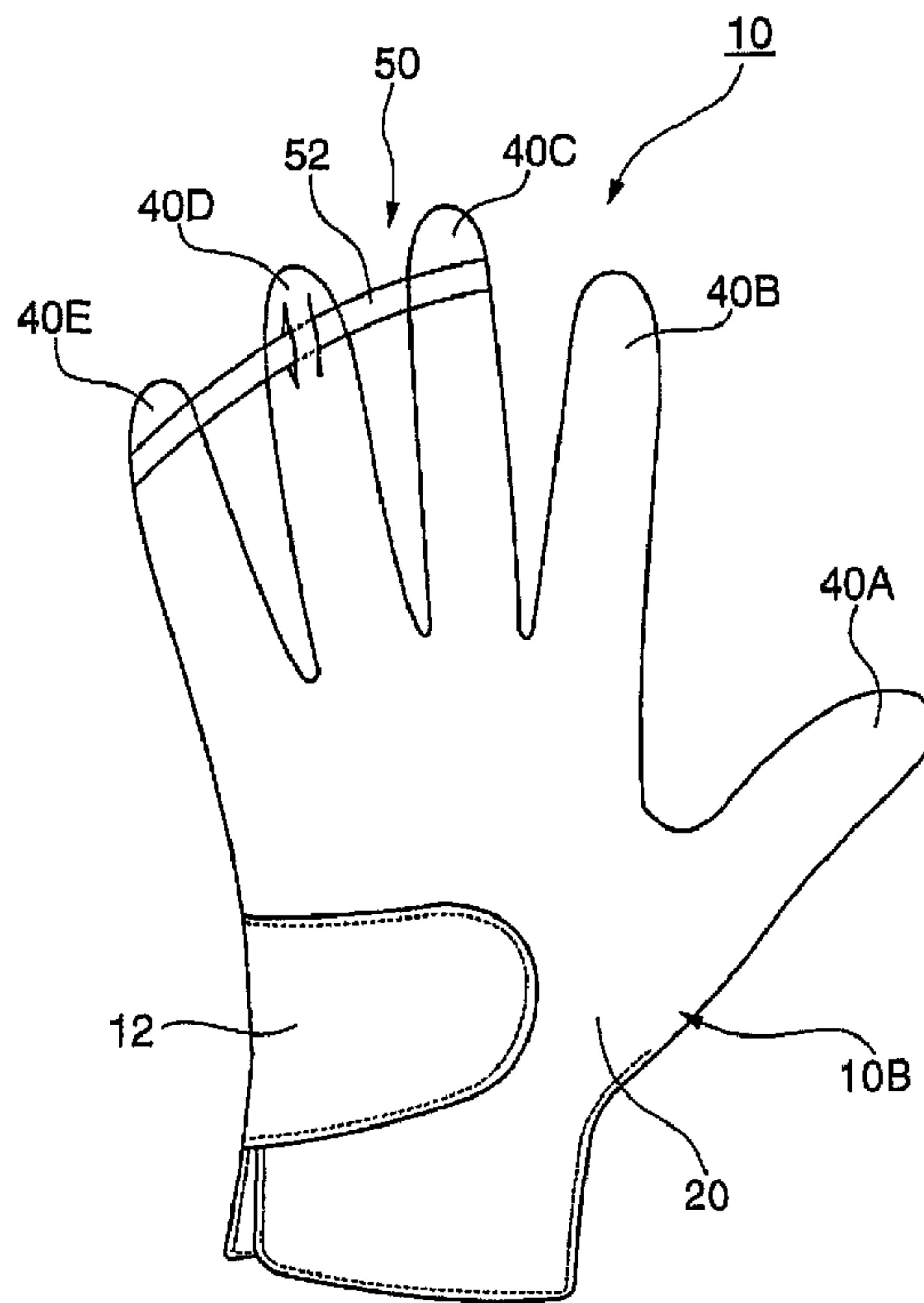

(86) Date de dépôt PCT/PCT Filing Date: 2008/09/09
 (87) Date publication PCT/PCT Publication Date: 2010/03/18
 (45) Date de délivrance/Issue Date: 2014/05/27
 (85) Entrée phase nationale/National Entry: 2011/03/03
 (86) N° demande PCT/PCT Application No.: JP 2008/066246
 (87) N° publication PCT/PCT Publication No.: 2010/029614

(51) Cl.Int./Int.Cl. *A41D 19/00* (2006.01)
 (72) Inventeur/Inventor:
 WATANABE, MASAEI, JP
 (73) Propriétaire/Owner:
 NDC CORPORATION, JP
 (74) Agent: ROBIC

(54) Titre : GANT ET SA FIXATION
 (54) Title: GLOVE AND ATTACHMENT THEREFOR



(57) Abrégé/Abstract:

A glove (10) has a glove body (10B) having five, thumb and finger insertion sections (40A-40E). A catch cord (52) is placed on the back side of a user's hand across at least three finger insertion sections (40C, 40D, 40E) among the five, thumb and finger



(57) **Abrégé(suite)/Abstract(continued):**

insertion sections (40A-40E) and is held by each of the at least three finger insertion sections. The three finger insertion sections (40C, 40D, 40E) correspond to the second finger, the third finger, and the fourth finger of the hand. The catch cord (52) is adapted to be able to adjust a gap between adjacent ones of the finger insertion sections (40C, 40D, 40E). To pull and remove all the finger insertion sections (40A-40E) of the glove (10) from the fingers at the same time, the fourth finger of the hand not wearing the glove (10) is engaged with the catch cord (52) and the finger insertion sections (40A, 40B) of the glove (10) which correspond to the thumb and the first finger are held and pulled by the thumb and the first finger of the hand not wearing the glove (10).

(12) 特許協力条約に基づいて公開された国際出願

(19) 世界知的所有権機関
国際事務局

(10) 国際公開番号

WO 2010/029614 A1

(43) 国際公開日
2010年3月18日(18.03.2010)

- (51) 国際特許分類:
A41D 19/00 (2006.01)
- (21) 国際出願番号: PCT/JP2008/066246
- (22) 国際出願日: 2008年9月9日(09.09.2008)
- (25) 国際出願の言語: 日本語
- (26) 国際公開の言語: 日本語
- (71) 出願人(米国を除く全ての指定国について): 株式会社エヌディーシー(NDC CORPORATION) [JP/JP]; 〒2080021 東京都武蔵村山市三ツ藤1丁目6番地の13 Tokyo (JP).
- (72) 発明者; および
- (75) 発明者/出願人(米国についてのみ): 渡辺政榮 (WATANABE, Masaei) [JP/JP]; 〒2080021 東京都武蔵村山市三ツ藤1丁目6番地の13 Tokyo (JP).
- (74) 代理人: 菊池新一, 外(KIKUCHI, Shinichi et al.); 〒1030001 東京都中央区日本橋小伝馬町6-11, KL日本橋ビル4F Tokyo (JP).
- (81) 指定国(表示のない限り、全ての種類の国内保護が可能): AE, AG, AL, AM, AO, AT, AU, AZ, BA, BB, BG, BH, BR, BW, BY, BZ, CA, CH, CN, CO, CR, CU, CZ, DE, DK, DM, DO, DZ, EC, EE, EG, ES, FI, GB, GD, GE, GH, GM, GT, HN, HR, HU, ID, IL, IN, IS, JP, KE, KG, KM, KN, KP, KR, KZ, LA, LC, LK, LR, LS, LT, LU, LY, MA, MD, ME, MG, MK, MN, MW, MX, MY, MZ, NA, NG, NI, NO, NZ, OM, PG, PH, PL, PT, RO, RS, RU, SC, SD, SE, SG, SK, SL, SM, ST, SV, SY, TJ, TM, TN, TR, TT, TZ, UA, UG, US, UZ, VC, VN, ZA, ZM, ZW.
- (84) 指定国(表示のない限り、全ての種類の広域保護が可能): ARIPO (BW, GH, GM, KE, LS, MW, MZ, NA, SD, SL, SZ, TZ, UG, ZM, ZW), ユーラシア (AM, AZ, BY, KG, KZ, MD, RU, TJ, TM), ヨーロッパ (AT, BE, BG, CH, CY, CZ, DE, DK, EE, ES, FI, FR, GB, GR, HR, HU, IE, IS, IT, LT, LU, LV, MC, MT, NL, NO, PL, PT, RO, SE, SI, SK, TR), OAPI (BF, BJ, CF, CG, CI, CM, GA, GN, GQ, GW, ML, MR, NE, SN, TD, TG).
- 添付公開書類:
— 国際調査報告(条約第21条(3))

(54) Title: GLOVE AND ATTACHMENT THEREFOR

(54) 発明の名称: 手袋及びその付属品

[図1]

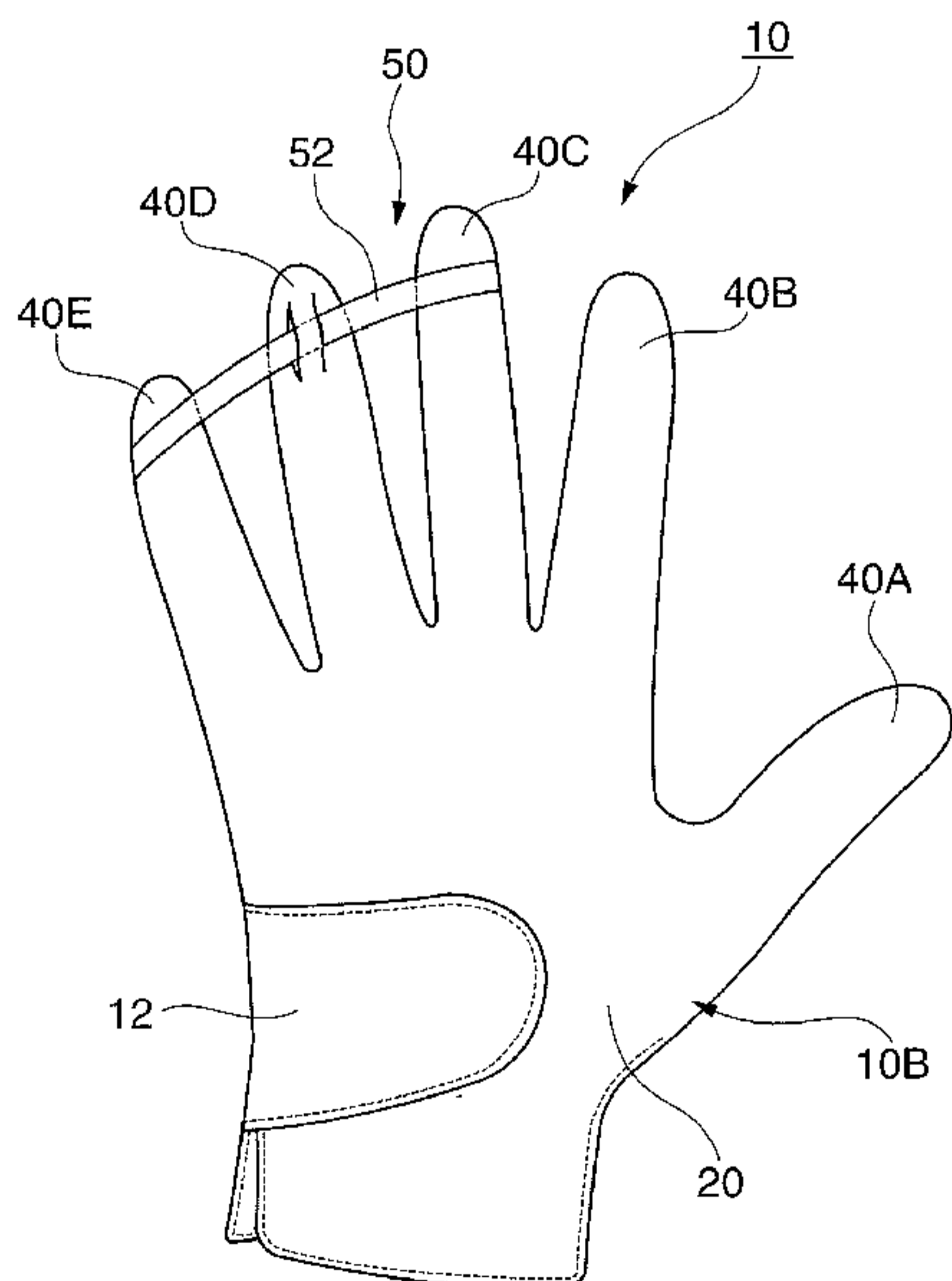

(57) Abstract: A glove (10) has a glove body (10B) having five, thumb and finger insertion sections (40A-40E). A catch cord (52) is placed on the back side of a user's hand across at least three finger insertion sections (40C, 40D, 40E) among the five, thumb and finger insertion sections (40A-40E) and is held by each of the at least three finger insertion sections. The three finger insertion sections (40C, 40D, 40E) correspond to the second finger, the third finger, and the fourth finger of the hand. The catch cord (52) is adapted to be able to adjust a gap between adjacent ones of the finger insertion sections (40C, 40D, 40E). To pull and remove all the finger insertion sections (40A-40E) of the glove (10) from the fingers at the same time, the fourth finger of the hand not wearing the glove (10) is engaged with the catch cord (52) and the finger insertion sections (40A, 40B) of the glove (10) which correspond to the thumb and the first finger are held and pulled by the thumb and the first finger of the hand not wearing the glove (10).

(57) 要約: 手袋本体10Bの5つの指挿入部40A乃至40Eのうち、少なくとも中指と薬指と小指に相応する3つの指挿入部40C、40D、40Eに跨って隣り合う指挿入部の間隔を調整することができるようにしてこれらの3つの指挿入部の甲側に配置されてこれらの指挿入部にそれぞれ保持された1つの引っ掛け用索条52を含み、手袋を嵌めていない手側の小指を引っ掛け用索条52に引っ掛け、手袋10を嵌めていない親指と人差し指等で手袋10の親指及び人差し指に相応する指挿入部40A、40Bを掴まむことによって、すべて指から手袋10のすべての指挿入部40A乃至40Eを同時に引き外すことができる。

GLOVE AND ATTACHMENT THEREFOR

TECHNICAL FIELD

[0001]

This invention relates to a glove adapted to be able to be easily removed by a wearer and an attachment therefor and relates to a glove having a structure suitable for a sport glove such as a golf glove and a baseball glove (a glove used on batting in a baseball) required to be frequently worn and removed during playing.

BACKGROUND OF TECHNOLOGY

10 [0002]

In general, the glove comprises a back part, a palm part and five finger insertion parts extending from the back and palm parts. The sport glove such as a golf glove is worn by a player so as to be able to open and close to the back parts a closing piece extending from the palm part by a surface fastener.

[0003]

For example, a golf player will sometimes remove its glove for various reasons not only after the end of the play, but also during playing. For instance, when carrying out an approach shot or a putting or when taking out something from its caddie bag between adjacent greens, the golf player may sometimes remove its
20 golf glove.

[0004]

In the case of performing the approach shot or the putting, it is required to remove the golf glove as soon as possible in order to play quickly. In order that the golf player is able to grasp a golf club while the golf glove closely engages the golf club, in general, the golf glove is worn by the player while closely engaging the back, the palm and the fingers of the player.

Therefore, it takes considerable time to remove the golf glove and especially, since the finger insertion parts are removed while individually pulling the tops of the finger insertion parts one by one, it takes substantial time to remove all the finger insertion parts out of the fingers corresponding to the
5 finger insertion parts. Since the golf glove more closely engages the hand at the time of play in rain than at that when it does not rain, it would be much more difficult to remove the golf glove.

[0005]

The reason why the golf player removes the golf glove when carrying
10 out the approach shot or the putting is that it tends to control the golf club more easily when it grasps the golf club with empty hands than otherwise. There are some conventional golf clubs adapted to get the same state as if the golf glove is removed by partially thinning the third, fourth and fifth finger insertion parts of the golf glove (see Patent Document 1)

15 [0006]

However, the golf glove having such a structure has a complicated structure, its manufacture is troublesome and in addition thereto, it is difficult to effectively make a control of the approach shot or the putting as played with the empty hand even if the finger insertion parts are partially
20 thinned. It would be more preferable if the golf glove could be easily removed. If the golf glove could be removed easily, it would be also convenient when it is required to remove the golf glove at the time other than when the approach shot or the putting is performed.

[0007]

25 There have been proposed various structures of a general glove adapted to easily remove the glove. For example, there has been proposed a fingertip-opened type glove having a finger hooking ring portion provided near a tip of an arbitrary finger insertion part on the back side of the

glove so as to cross the finger insertion part in the direction where the finger extends (see Patent Documents 2). The glove of such a structure can be removed by hooking the finger engaging ring any finger of the opposite hand. However, in the case of the sport glove, since the palm is a side where the club, the bat or the like is grasped, it will interfere with grasping the club, the bat, etc. and in order to remove the glove quickly, it is necessary to provide the finger hooking ring in as many finger insertion parts as possible. But, since this requires every finger insertion parts to be hooked by the corresponding finger of the opposite hand, it takes considerable time for the hooking operation of all the fingers which is ready to remove the glove and therefore, this operation will disadvantageously interfere with removing the glove quickly.

[0008]

There has been proposed a structure of a glove in which a string is connected between the adjacent finger penetration ports of the glove having no finger insertion parts (see Patent Documents 3). Even if such a structure may be applied to the glove having finger insertion parts, the strings are located at a root between all the finger insertion parts and therefore when the strings between the adjacent finger insertion parts should be hooked by the corresponding fingers, respectively, similarly, it takes substantial time to remove the glove. Further, since there are interposed the hooking strings between the adjacent finger insertion parts, the close engagement between the fingers of the hand will be interfered. It is not preferable for grasping the club, the bat or the like in case of being used as the sport glove grasping it. Furthermore, since the second finger is restrained by the string, when it is used as the golf glove, the golf clubs cannot be gripped.

[0009]

[Patent Documents 1] JP11-267263A

[Patent Documents 2] Registered utility model No. 3122714

[Patent Documents 3] JU6-30116A

DISCLOSURE OF THE INVENTION

PROBLEMS TO BE SOLVED BY THE INVENTION

[0010]

10 One of the problems to be solved by the invention is to provide a glove in which a distance between adjacent fingers when it is worn is never restrained, a close engagement of the adjacent fingers is never interfered with and a glove body in the state of being worn can be removed out of every fingers simultaneously in a single operation.

[0011]

Another problem to be solved by the invention is to provide attachment for a glove suitable for being used while attached to a glove body of the glove so that a distance between adjacent fingers when the glove is worn is never restrained, a close engagement of the adjacent fingers is never interfered with and the glove body in the state of being worn can be removed out of every fingers simultaneously in a single operation.

MEANS TO SOLVE THE PROBLEMS

[0012]

20 In order to provide an improvement over the prior art, and according to the present invention, there is provided a glove comprising a glove body including a back part and a palm part integrally joined so as to cover a back and a palm of a hand of a wearer and five finger insertion parts extending from ends of said back part and said palm to cover each finger of said wearer, respectively, said glove characterized by being provided with glove body removal means including a single hooking cord disposed on the back side of said finger insertion parts and over at least three finger insertion parts corresponding to a middle finger, a third finger and a little finger among said five finger

insertion parts of said glove body such that as said hooking cord is hooked by a little finger of an empty hand said three finger insertion parts are pulled simultaneously so as to adjust a distance between adjacent finger insertion parts, said glove body removal means further including fixing portions where both ends of said hooking cord are fixed to said finger insertion parts for said middle and little fingers, respectively and a holding portion where a middle portion of said hooking cord is held and wherein said holding portion holds said hooking cord at said finger insertion part corresponding to said third finger so that said hooking cord can move in a lateral direction relative to said third finger insertion part.

10 According to another aspect of the present invention, there is also provided an attachment to be attached onto a glove comprising a glove body including a back part and a palm part integrally joined to each other so as to cover a back and a palm of a hand of a wearer and five finger insertion parts extending from leading ends of said back part and said palm to cover each of fingers of said wearer, respectively, said attachment characterized by comprising glove body removal means including a single hooking cord disposed on the back side of said finger insertion parts and over at least three finger insertion parts corresponding to a middle finger, a third finger and a little finger among said five finger insertion parts of said glove body as said hooking cord is hooked by a little finger of an empty hand said three finger insertion
20 parts are pulled simultaneously so as to adjust a distance between adjacent finger insertion parts, said glove body removal means includes fixing portions where both ends of said hooking cord are fixed to said finger insertion parts for said middle and little fingers, respectively and a holding portion where a middle portion of said hooking cord is held, said holding portion comprising a holding piece to be attached by sewing, thermal melting adhesion, adhesive or surface attachment to said finger insertion part corresponding to said third finger so that said hooking cord is held at

said finger insertion part while said hooking cord is allowed to move in a lateral direction.

Other aspects, means, possible embodiments, variants and/or resulting advantages of the present invention, all being preferred and/or optional, are briefly summarized hereinbelow.

For example, a first means to solve one of the problems is to provide a glove comprising a glove body including a back part and a palm part integrally joined to each other so as to cover a back and a palm of a hand of a wearer and five finger insertion parts extending from ends of said back part and said palm to cover each
10 finger of said wearer, respectively, said glove further characterized by being provided with glove body removal means including a hooking cord disposed on the back side of said finger insertion parts and attached over and to at least three finger insertion parts corresponding to a middle finger, a third finger and a little finger among said five finger

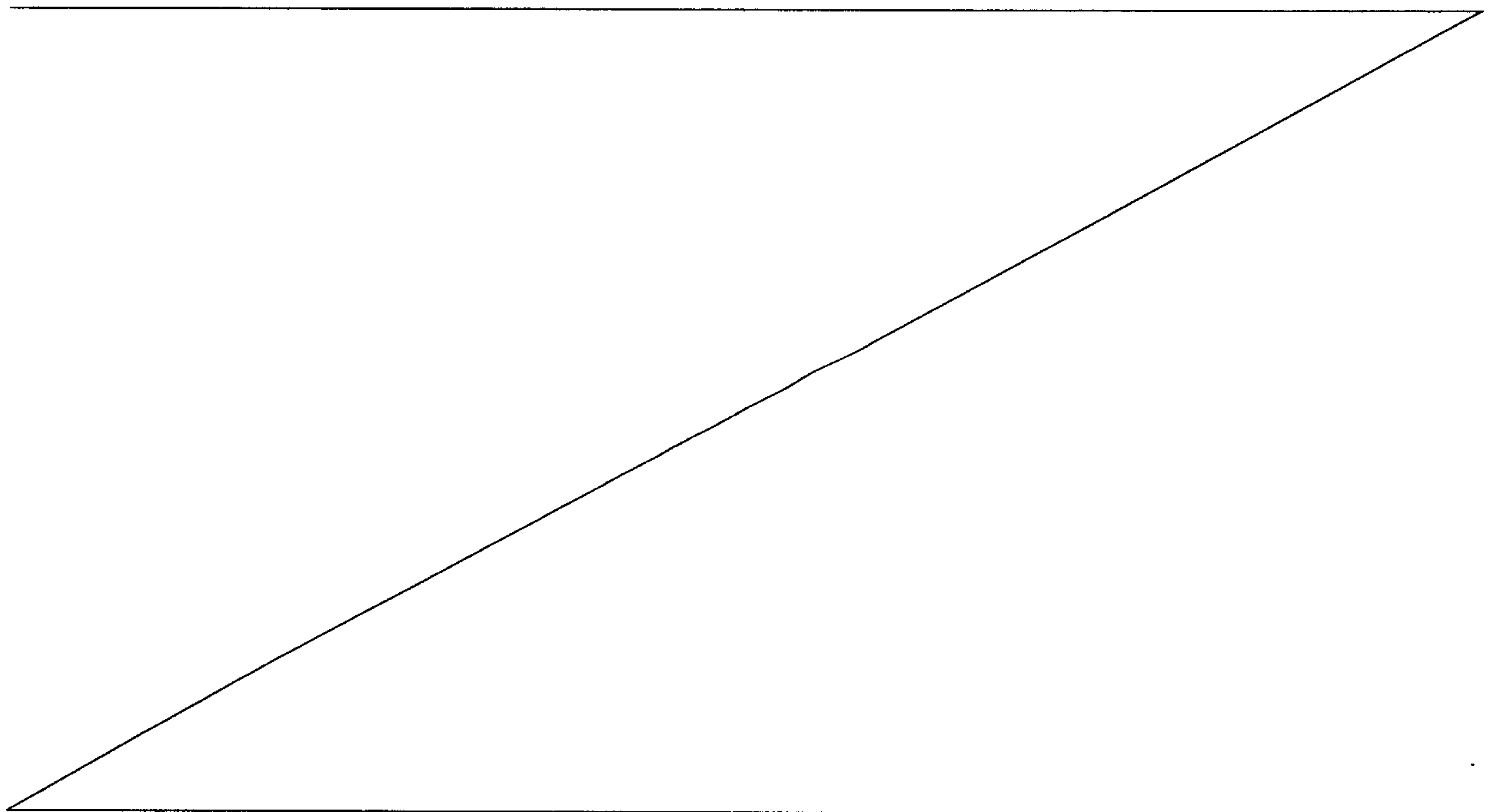

insertion parts of said glove body so as to adjust a distance between adjacent finger insertion parts whereby said three finger insertion parts can be pulled simultaneously while said hooking cord is hooked by a little finger of an empty hand.

5 [0013]

In the first means to be solved by the invention, the glove body removal means further includes fixing portions where both ends of said hooking cord are fixed to said finger insertion parts for said middle and little fingers, respectively and a holding portion where a middle portion of said
10 hooking cord is held.

[0014]

In this case, the holding portion preferably holds said hooking cord at the finger insertion part corresponding to the third finger so that said hooking cord can move in a lateral direction relative to said third finger
15 insertion part.

[0015]

The fixing portions may be formed by fixing the hooking cord directly to the finger insertion parts or may comprise a fixing piece fixed to the hooking cord and attached to the finger insertion parts by sewing, thermal
20 melting adhesion, adhesive or surface attachment.

[0016]

On the other hand, the holding portion may comprise a cloth portion between a pair of longitudinal slits which are provided in the back side of the finger insertion part corresponding to the third finger and which the hooking
25 cord penetrates or may comprise a holding piece attached to the back side of the finger insertion part corresponding to the third finger so that the hooking cord extends through the holding piece.

[0017]

The second means to be solved by the invention is to provide an attachment to be attached onto a glove comprising a glove body including a back part and a palm part integrally joined to each other so as to cover a back and a palm of a hand of a wearer and five finger insertion parts extending
5 from ends of said back part and said palm to cover each finger of said wearer, respectively, said attachment characterized by comprising glove body removal means including a hooking cord disposed on the back side of said finger insertion parts and attached over and to at least three finger insertion parts corresponding to a middle finger, a third finger and a little finger among said
10 five finger insertion parts of said glove body so as to adjust a distance between adjacent finger insertion parts whereby said three finger insertion parts can be pulled simultaneously while said hooking cord is hooked by a little finger of an empty hand.

[0018]

15 In the second means to be solved by the invention, the glove body removal means includes fixing portions where both ends of said hooking cord are fixed to said finger insertion parts for said middle and little fingers, respectively and a holding portion where a middle portion of said hooking cord is held. The holding portion may preferably comprise a holding piece to
20 be attached by sewing, thermal melting adhesion, adhesiven or surface attachment to the finger insertion part corresponding to the third finger so that the hooking cord is held in the finger insertion part while the hooking cord is allowed to move in a lateral direction.

[Effect of the Invention]

25 [0019]

According to the invention, since the glove comprises glove body removal means including a hooking cord disposed on the back side of said finger insertion parts and attached over and to at least three finger insertion

parts corresponding to the middle finger, the third finger and the little finger among the five finger insertion parts of the glove body so as to adjust a distance between the adjacent finger insertion parts whereby the three finger insertion parts can be pulled simultaneously while said hooking cord is hooked by the little finger of the empty hand.

[0020]

Since the glove can freely adjust the distance between each another of the finger insertion parts, there is no problem in grasping the club, the bat or the like when it is applied to the sport glove such as the golf glove or the baseball glove. Especially, as the hooking cord can move laterally relative to the third finger, the third finger can more freely control the distance relative to the middle finger and the little finger on both sides thereof and therefore the finger insertion parts are never restrained. Since the hooking cord is provided so that it never enters the space between the adjacent fingers, the mutual close engagement of the fingers is never prevented and the feeling of free use can be imparted to the glove in the same manner as that of the glove having no hooking cord.

[0021]

Since the glove body removal means can be attached to the glove by fixing the hooking cord itself or its fixing piece and its holding piece to the finger insertion parts by sewing, thermal melting adhesion, adhesive or surface attachment, its manufacture is easy and also it may be easily attached to the already existing glove having no glove body removal means.

BRIEF DESCRIPTION OF THE DRWAINGS

[0022]

Fig. 1 is a front view of a golf glove constructed in accordance with one form of embodiment of the invention;

Fig. 2 is a back view of the golf glove of Fig. 1;

Fig. 3 is an enlarged front view of glove body removal means of the golf glove of Figs. 1 and 2;

Fig. 4 illustrates a fixing portion and a holding portion of the glove body removal means of Fig. 3, in which Fig. 4(A) is a cross sectional view taken along a line A-A of Fig. 3 in order to show the fixing portion and Fig. 4(B) is a cross sectional view taken along a line B-B of Fig. 3 in order to show the holding portion;

Fig. 5 is a block diagram showing the procedure when the golf glove of Fig. 2 is removed;

Fig. 6 is a perspective view in the state where the golf glove of Fig. 2 is worn and the golf club is grasped;

Fig. 7 is an enlarged front view of glove body removal means according to another form of embodiment of the invention;

Fig. 8 illustrates a fixing portion and a holding portion of the glove body removal means of Fig. 7, in which Fig. 4(A) is a cross sectional view taken along a line A-A of Fig. 7 in order to show the fixing portion and Fig. 4(B) is a cross sectional view taken along a line B-B of Fig. 7 in order to show the holding portion; and

Fig. 9 illustrates an attachment for a golf glove suitable for being attached to the golf glove and easily removing the golf glove, in which Fig. 9(A) is a front view thereof and Fig. 9(B) is a longitudinal cross sectional view thereof.

BEST MODE OF EMBODIMENT OF INVENTION

[0023]

A best form for carrying out the invention will be explained based on the drawings later. A glove 10 according to one form of embodiment of the invention is described with reference to Figs. 1 through 3. Although the glove 10 is shown to be a golf glove in the illustrated form, the invention may be

applied to sport gloves other than the golf glove and other general gloves in addition to a golf glove. This glove may be made of natural leather, synthetic leather or other proper material.

[0024]

5 The glove 10 has a glove body 10B comprising a back part 20 and a palm part 30 joined to each other so as to wrap the back and palm of a hand of a wearer and five finger insertion parts 40A, 40B, 40C, 40D and 40E formed by extending from the leading ends of the back and palm parts 20 and 30. and to cover each fingers of the hand of the wearer. In Fig. 1, a reference
10 numeral 12 designates a closing piece for closing an opening between the back and palm parts 20 and 30 on the side of the wrist of the hand with a surface fastener to prevent the glove body 10B from being removed from the hand.

[0025]

15 The glove 10 of the invention further includes glove body removal means 50 having a single hooking cord 52 disposed on the back side of at least three finger insertion parts 40C, 40D and 40E corresponding to a middle finger, a third finger and a little finger among the five finger insertion parts 40A through 40E of the glove body 10B and attached over and to the three
20 finger insertion parts so as to adjust a distances between the adjacent finger insertion parts 40C and 40D or 40D and 40E whereby these three finger insertion parts can be pulled simultaneously while the hooking cord 52 is hooked by a little finger of an empty hand. The hooking cord 52 may be also made of the same material as that of the glove body 10B, but if the hooking
25 cord can be fixed to the finger insertion parts, it may be made of different material such as plastic string, plastic strip or other material.

[0026]

The glove body removal means 50 further includes fixing portions 54C

and 54E where both ends of the hooking cord 52 are fixed to the finger insertion parts 40C and 40E for the middle and little fingers, respectively and a holding portion 54D where a middle portion of the hooking cord 52 is held at the finger insertion part 40D for the third finger. In the illustrated form, 5 the holding portion 54D holds the finger insertion part 40D for the third finger so that the hooking cord 52 can move laterally relative to the finger insertion part 40D corresponding to the third finger.

[0027]

In the illustrated form, the fixing portions 54C and 54E are formed by 10 sewing on the hooking cord 52. Explaining with reference to Fig. 4 in more details, the fixing portion 54E is formed as shown in Fig. 4(A) by inserting the end 52e of the cord 52 into the outside sewing portion 40EM of the back-side and palm-side clothes of the finger insertion part 40E and sewing the former onto the latter and also sewing the cord portion corresponding to the inside 15 sewing portion 40EM of the back-side and palm-side cloths of the finger insertion part 40E or the cord portion further inside thereof to the back-side cloth portion of the finger insertion part 40E. The fixing part 54C may be formed similarly, but it may be formed in the same manner as the form in which the side of the finger insertion part 40C facing the first finger is 20 inserted in the same form as the outside form of the outside sewing portion 40E of the fixing portion 54E inserted and by sewing the side of the finger insertion part 40C facing the third finger to the back-side cloth portion of the finger insertion part 40C in the same form as the inside form of the fixing portion 54E. Otherwise, the end 52e of the cord 52 may be sewn to the 25 back-side cloth portion of the finger insertion part 54E without any insertion of the end 52e of the cord 52 into the outside sewing portion 40EM of the finger insertion part 54E. In the illustrated form, the cord 52 is fixed to both sides of the finger insertion parts 40C and 40E, but may be fixed only to

either of both sides thereof. In any case, it is required that the cord 52 is never exposed on the side of the palm or never enters the space between the adjacent fingers whereby the close engagement of the adjacent fingers to each other caused by the cord 52 interposed between the adjacent fingers is never prevented when the glove is worn. Normally, the middle finger insertion 40C and the first finger insertion part 40B are never closely engaged with each other when the golf club is gripped (see Fig. 6) and therefore, there is no trouble even if the other end (the end opposite to the end 52e) of the cord 52 is inserted into the sewing portion of the first finger insertion part 40C on the side of the first finger insertion part 40B, but this end of the cord may be sewed to the back-side cloth portion of the finger insertion part further inside of the sewing portion.

[0028]

In the illustrated form, the holding portion 54D comprises a cloth piece 40DPA between a pair of longitudinal slits 40DS provided in the back side cloth of the finger insertion part 40D for the third finger and through which the hooking cord 52 extends (see Figs. 3 and 4 (B)). The hooking cord 52 is held at the finger insertion part 40D by extending through these longitudinal slits 40DS so that it passes through the inner face of the cloth piece 40DPA whereby the cord 52 is able to move freely in a transverse direction through these longitudinal slits 40DS. In Fig. 4 (B), reference numerals 40DM designate the sewing portions of the back-side and palm-side cloth portions of the finger insertion part 40D.

[0029]

Next, explaining a state where the golf glove 10 shown in Figs. 1 and 2 is used, this golf glove 10 will be used with the glove body 10B engaged in a left hand (in the case of a right-handed person) as usually. The length of the hooking cord 52 of the glove body removal means 50 is so set as to be able to

adjust the distance between the adjacent finger insertion parts 40C and 40D or between the adjacent finger insertion parts 40D and 40E of the finger insertion parts 40C through 40E corresponding to the middle finger, the third finger and the little finger, respectively, and the hooking cord 52 is held in the glove body 10B so that the cord is able to move in the traverse direction relative to the finger insertion part 40D corresponding to the third finger. Thus, when a player wears the golf glove 10 or when it grips a golf club through the golf glove 10 as shown in Fig. 6, the hooking cord 52 never restrains the distance between two of these finger insertion parts 40C, 40D and 40E and therefore causes no trouble. Especially, since the hooking cord 52 is disposed along the back side of the finger insertion parts 40C, 40D and 40E and the hooking cord 52 itself and its fixing portions 54C and 54E never enter between the adjacent fingers, this golf glove never damages contact feeling on the palm side and between the adjacent fingers from the middle finger to the little finger in the same manner as the conventional glove having no glove body removal means and the hooking cord 52 can closely engage these fingers to each other. In case that the glove is the golf glove, the close engagement between the palm face and the golf club and between the adjacent fingers from the middle finger to little finger is extremely important for gripping the golf club. The glove of Figs. 1 through 4 is more advantageous because the close engagement between the palm and the golf club and between the adjacent fingers is never damaged.

[0030]

In case where the wearer (player) wants to remove the golf glove at the time such as the as the player makes an approach shot or a putting, firstly the player opens the closing piece 12 (see a step 1 of Fig. 5), hooks the hooking cord 52 of the glove body removal means 50 between the middle and third fingers or between the third and little fingers with a little finger of an

opposite hand (an empty hand) not wearing the golf glove (see a step 2 of Fig. 5), grasping the leading ends of the finger insertion parts 40A and 40B corresponding to the thumb and the first finger together between and with a thumb and a first finger of the empty hand (see a step 3 of Fig. 5) and, in this state, pulls the hooking cord 52 and the finger insertion parts 40A and 40B simultaneously (see a step 4 of Fig. 5). In this manner, all the finger insertion parts 40A through 40E are pulled out of the corresponding thumb and fingers at the same time in a smooth manner whereby the golf glove 10 can be removed out of the hand in a single operation. The method to grasp the finger insertion parts 40A and 40B corresponding to the thumb and the first finger, respectively may be performed in a manner other than the aforementioned method to grasp them between the thumb and the first finger of the empty hand. The leading ends of the finger insertion parts 40A and 40B may be grasped between the thumb and the first finger and between the first and middle fingers, respectively. Also, in this case, by hooking the hooking cord 52 with the little finger of the empty hand, the whole glove body 10B can be drawn or pulled out simultaneously.

[0031]

Another form of the invention is shown in Figs. 7 and 8 and in this form, the fixing portions 54C and 54E may comprise fixing pieces 54CP and 54EP fixed to the hooking cord 52 and attached to the back side of the finger insertion parts 40C and 40E and the holding portion 54D may comprise a holding piece 54DPB attached to the back side of the finger insertion part 40D corresponding to the third finger so that the hooking cord 52 can extend through the holding piece 54DPB.

[0032]

The fixing piece 54CP and 54EP may be fixed to the hooking cord 52 by either of sewing, thermal melting adhesion or adhesive, but the most

preferable fixing means is the sewing illustrated (see Fig. 8 (A)). The fixing pieces 54CP and 54EP and the holding piece 54DPB may be attached to the finger insertion parts 40C, 40E and 40D, respectively by either of sewing, thermal melting adhesion, adhesive and surface adhesion (surface fastener).

5 The illustrated fixing means is shown to be adhesive (see Fig. 8(A)(B)). Although the fixing pieces 54CP and 54EP and the holding piece 54DPB have a width 54W considerably smaller than width 40W of the back side of the finger insertion parts 40C, 40E and 40D, the width 54W of the fixing pieces 54CP and 54EP and the holding piece 54DPB may be broader to the width

10 near the width 40W within the limit of the width 40W of the back side of the finger insertion parts 40C, 40E and 40D. In Fig. 8 (B), a reference numeral 54DG designates a gap formed between the back side cloth of the finger insertion part 40D and the holding piece 54DPB so that the hooking cord 52 can freely move in a transverse direction (a direction traversing the finger)

15 between the back side cloth of the finger insertion part 40D and the holding piece 54DPB.

[0033]

In the form of embodiment of Figs. 7 and 8, as long as the fixing pieces 54CP, 54EP and 54DPB can withstand the pulling force, they may be

20 fixed to the finger insertion parts 40C, 40E and 40D with a surface fastener (surface fixture) etc., respectively.

[0034]

Although the invention provides an attachment 10AC adapted to be attached to a already existing glove having no glove body removal means

25 as a retrofit product or a product to be attached late. The detail of one form of embodiment of the attachment is illustrated in Fig. 9.

[0035]

As shown in Fig. 9, the attachment 10AC corresponds to a structural

body of the glove body removal means 50 independently separated from the
golf glove 10 of Figs. 1 or 7. More particularly, the attachment 10AC includes
the hooking cord 52, the fixing piece 54CP and 54EP to fix both ends of the
hooking cord 52 to the finger insertion parts 40C and 40E for the middle and
5 little fingers (see Figs. 1 and 2, ditto later), respectively and the holding piece
54DPC to hold the middle portion of the hooking cord 52 at the third finger
insertion part 40D so that the cord 52 can move rightward or leftward.

[0036]

The fixing pieces 54CP and 54EP may be fixed to the hooking cord 52
10 by sewing, thermal melting adhesion or adhesive while the holding piece
54DPC has a penetration hole 54DPCH which the hooking cord 52 penetrates
so that the hooking cord 52 can move rightward or leftward. If the holding
piece 54DPC can be held the hooking cord 52 until the attachment 10AC is
attached to the glove body 10B, then the penetration hole 54DPCH may not
15 be required to be provided and the holding piece 54DPC may hold the
hooking cord 52 by a holding string, for example. In this case, as the holding
piece 54DPC is fixed to the finger insertion part 40D, the hooking cord 52 will
be held at the finger insertion part 40D so that the cord can move rightward
or leftward between the holding piece 54DPC and the finger insertion part
20 40D.

[0037]

The fixing pieces 54CP and 54EP and the holding piece 54DPC may
have a pressure adhesive layer with a release paper attached thereto or a
thermal melting adhesion layer with a release paper attached thereto on the
25 undersurface thereof (the surface facing the finger insertion part). The fixing
pieces 54CP and 54EP and the holding piece 54DPC can be attached to the
corresponding finger insertion parts by pressurizing the pressure adhesive
layer to the corresponding finger insertion parts or forcing the thermal

melting adhesion layer while it is heated with an iron etc. after the release paper is removed.

[0038]

The glove (the golf glove, for example) having the same structure as
5 that shown in Figs. 1 and 2 can be obtained by attaching the fixing pieces
54CP and 54EP and the holding piece 54DPC of the attachment 10AC to the
finger insertion parts 40C, 40E and 40D of the glove body 10B, respectively.

[0039]

The fixing piece 54CP and 54EP may not necessarily be required and
10 it may have a fixing material formed of a pressure adhesive layer with a
release paper or a thermal melting adhesion layer with a release paper
provided on the undersurface of the both ends of the hooking cord 52.

[POSSIBILITY OF UTILIZATION IN INDUSTRIES]

[0040]

15 Since all the finger insertion parts of the glove of the invention can
be pulled out of the corresponding fingers by hooking the hooking cord with
the little finger of the hand (empty hand) not wearing the glove and grasping
the finger insertion parts corresponding to the thumb and the first of the golf
glove with the thumb and the first fingers etc., of the empty hand, the glove
20 can be removed in a single operation and therefore the removal operation of
the glove can be easily made, which can improve the possibility of utilization
in industries.

25

CLAIMS:

1. A glove (10) comprising a glove body (10B) including a back part (20) and a palm part (30) integrally joined so as to cover a back and a palm of a hand of a wearer and five finger insertion parts (40A-40E) extending from ends of said back part and said palm to cover each finger of said wearer, respectively, said glove characterized by being provided with glove body removal means (50) including a single hooking cord (52) disposed on the back side of said finger insertion parts (40A-40E) and over at least three finger insertion parts (40C-40E) corresponding to a middle finger, a third finger and a little finger among said five finger insertion parts of said glove body such that as said hooking cord (52) is hooked by a little finger of an empty hand said three finger insertion parts are pulled simultaneously so as to adjust a distance between adjacent finger insertion parts, said glove body removal means (50) further including fixing portions (54C,54E) where both ends of said hooking cord (52) are fixed to said finger insertion parts for said middle (40C) and little fingers (40E), respectively and a holding portion where a middle portion of said hooking cord is held and wherein said holding portion (54D) holds said hooking cord (52) at said finger insertion part (40E) corresponding to said third finger so that said hooking cord (52) can move in a lateral direction relative to said third finger insertion part.

20

2. A glove as set forth in claim 1, and wherein said fixing portions (54C,54E) are formed by fixing said hooking cord directly to said finger insertion parts.

3. A glove as set forth in claim 1, and wherein said fixing portions comprise a fixing piece fixed to said hooking cord and attached to said finger insertion parts by sewing, thermal melting adhesion, adhesive or surface attachment.

4. A glove as set forth in claim 2 or 3, and wherein said holding portion (54D) comprises of a cloth portion between a pair of longitudinal slits (40DS) which is provided in the back side of said finger insertion part corresponding to said third finger and through which said hooking cord (52) penetrates.

5 A glove as set forth in claim 2 or 3, and wherein said holding portion (54D) comprises a holding piece attached to said the back side of said finger insertion part corresponding to said third finger so that said hooking cord (52) extends through said holding piece.

10

6. An attachment to be attached onto a glove (10) comprising a glove body (10B) including a back part (20) and a palm part (30) integrally joined to each other so as to cover a back and a palm of a hand of a wearer and five finger insertion parts (40A-40E) extending from leading ends of said back part and said palm to cover each of fingers of said wearer, respectively, said attachment characterized by comprising glove body removal means (50) including a single hooking cord (52) disposed on the back side of said finger insertion parts and over at least three finger insertion parts (40C-40E) corresponding to a middle finger, a third finger and a little finger among said five finger insertion parts of said glove body as said hooking cord (52) is hooked by a little finger of an empty hand said three finger insertion parts are pulled simultaneously so as to adjust a distance between adjacent finger insertion parts, said glove body removal means (50) includes fixing portions (54C,54E) where both ends of said hooking cord are fixed to said finger insertion parts for said middle and little fingers, respectively and a holding portion (54D) where a middle portion of said hooking cord (52) is held, said holding portion (54D) comprising a holding piece to be attached by sewing, thermal melting adhesion, adhesive or surface attachment to said finger insertion part corresponding to said third finger so that said hooking

20

cord is held at said finger insertion part while said hooking cord (52) is allowed to move in a lateral direction.

FIG. 1

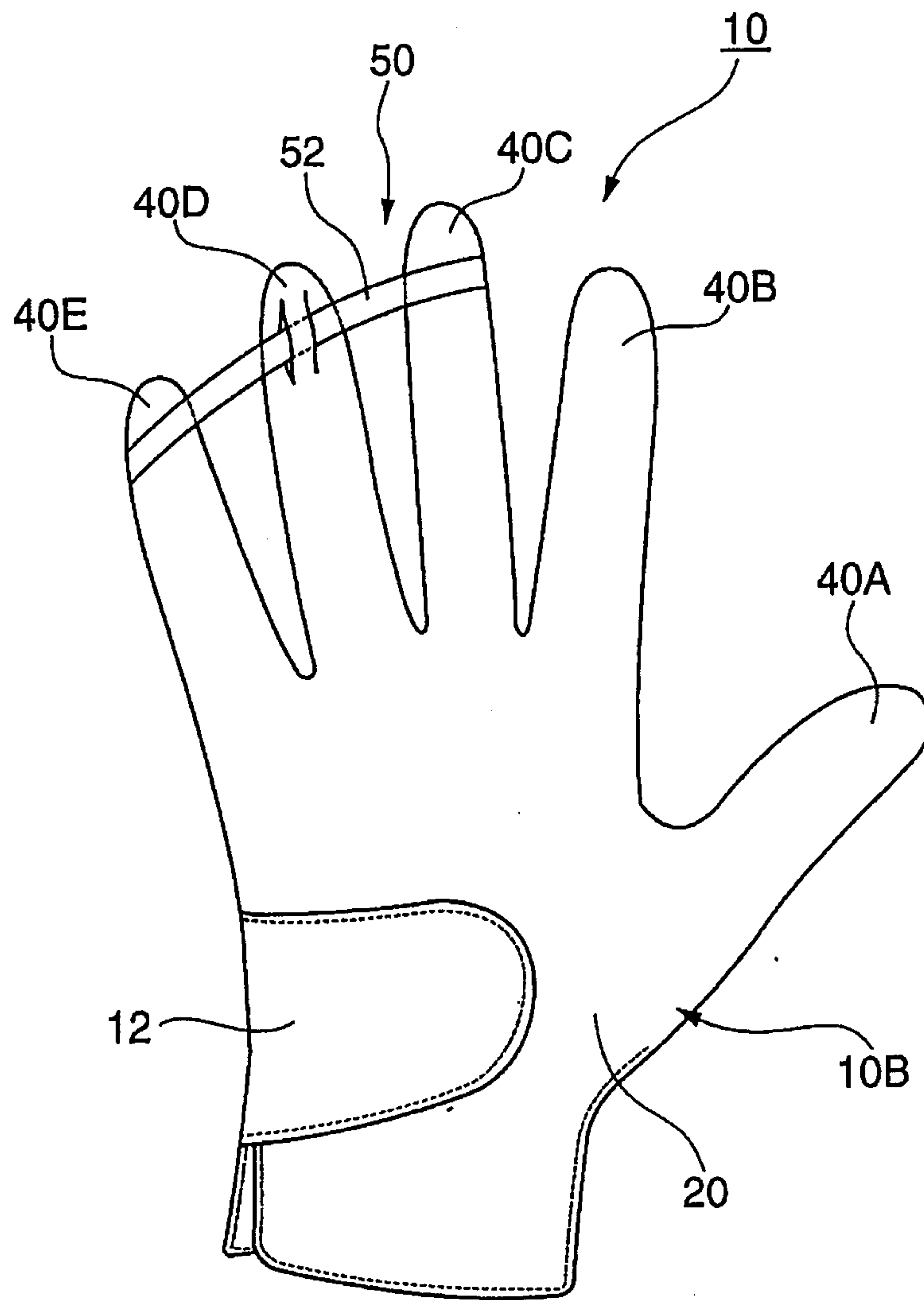

FIG. 2

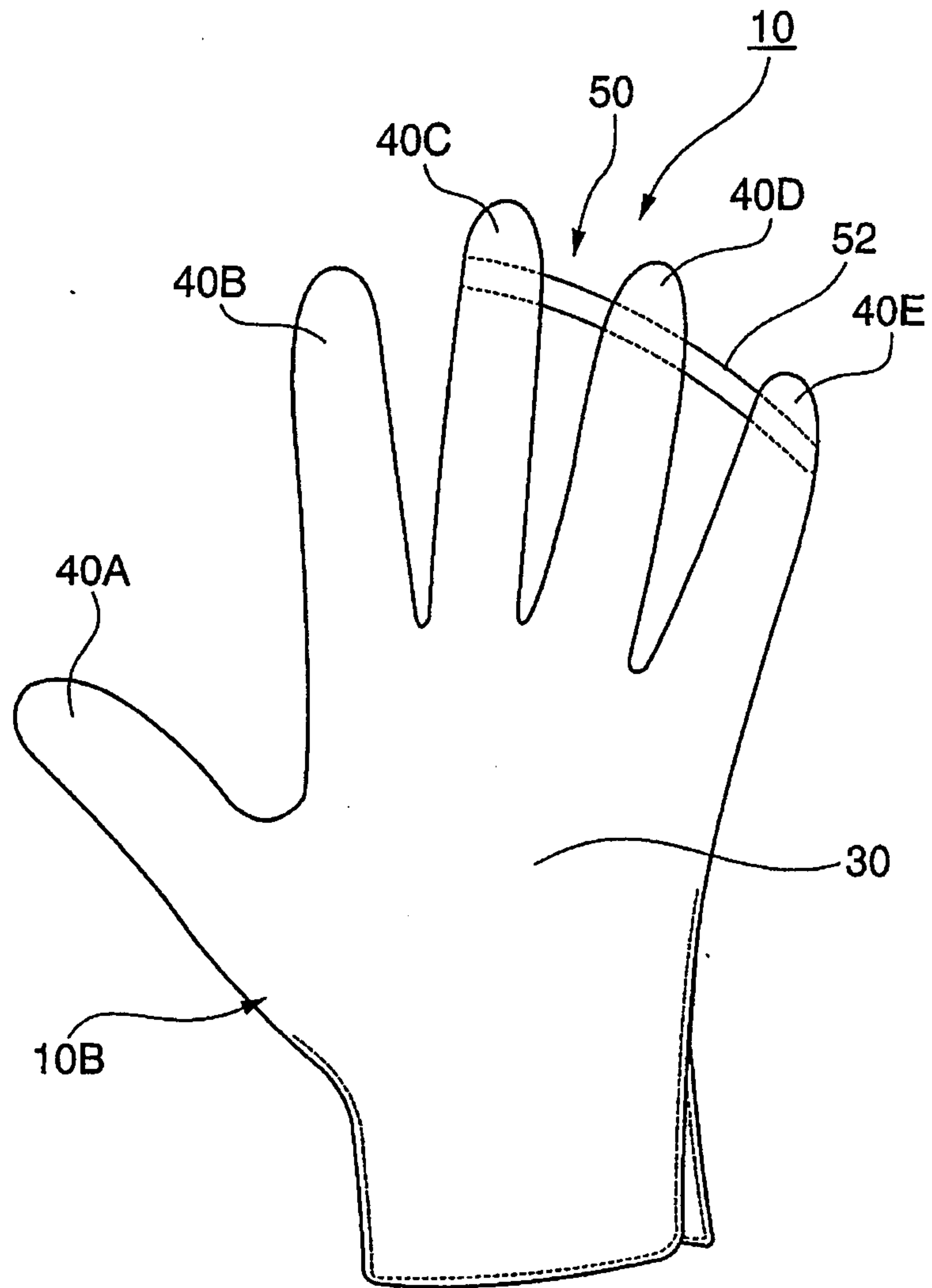

FIG. 3

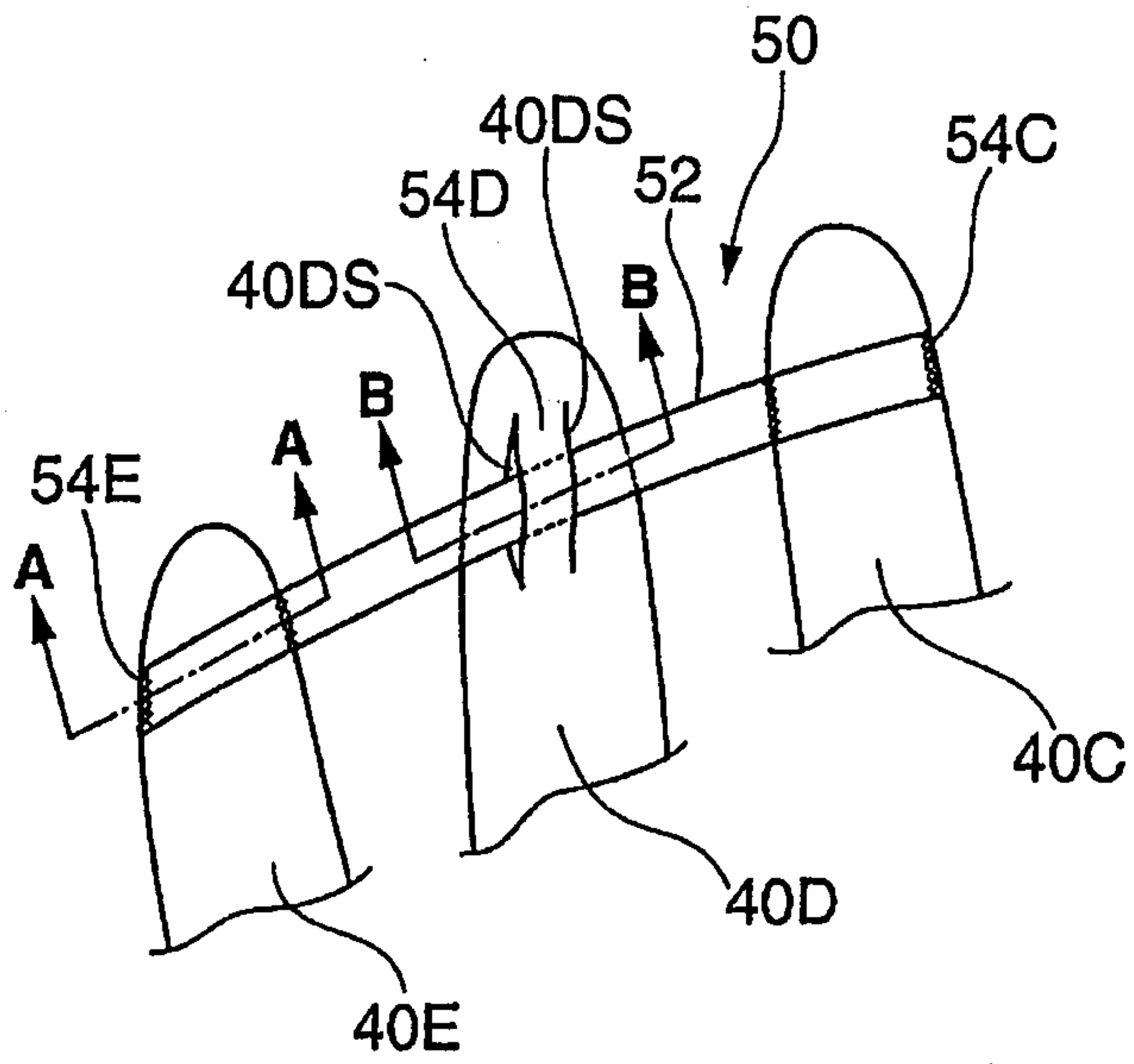

FIG. 4

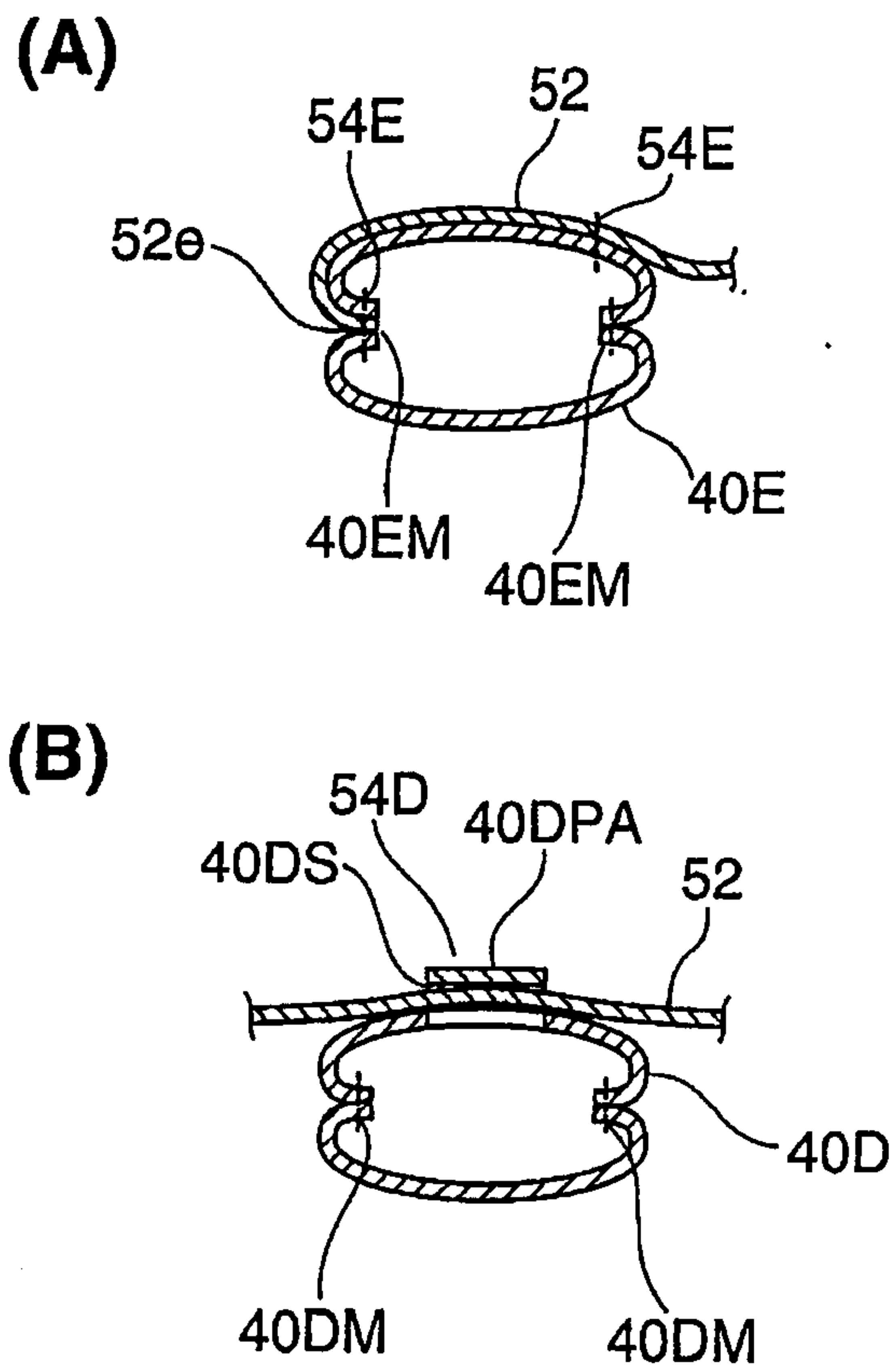

FIG. 5

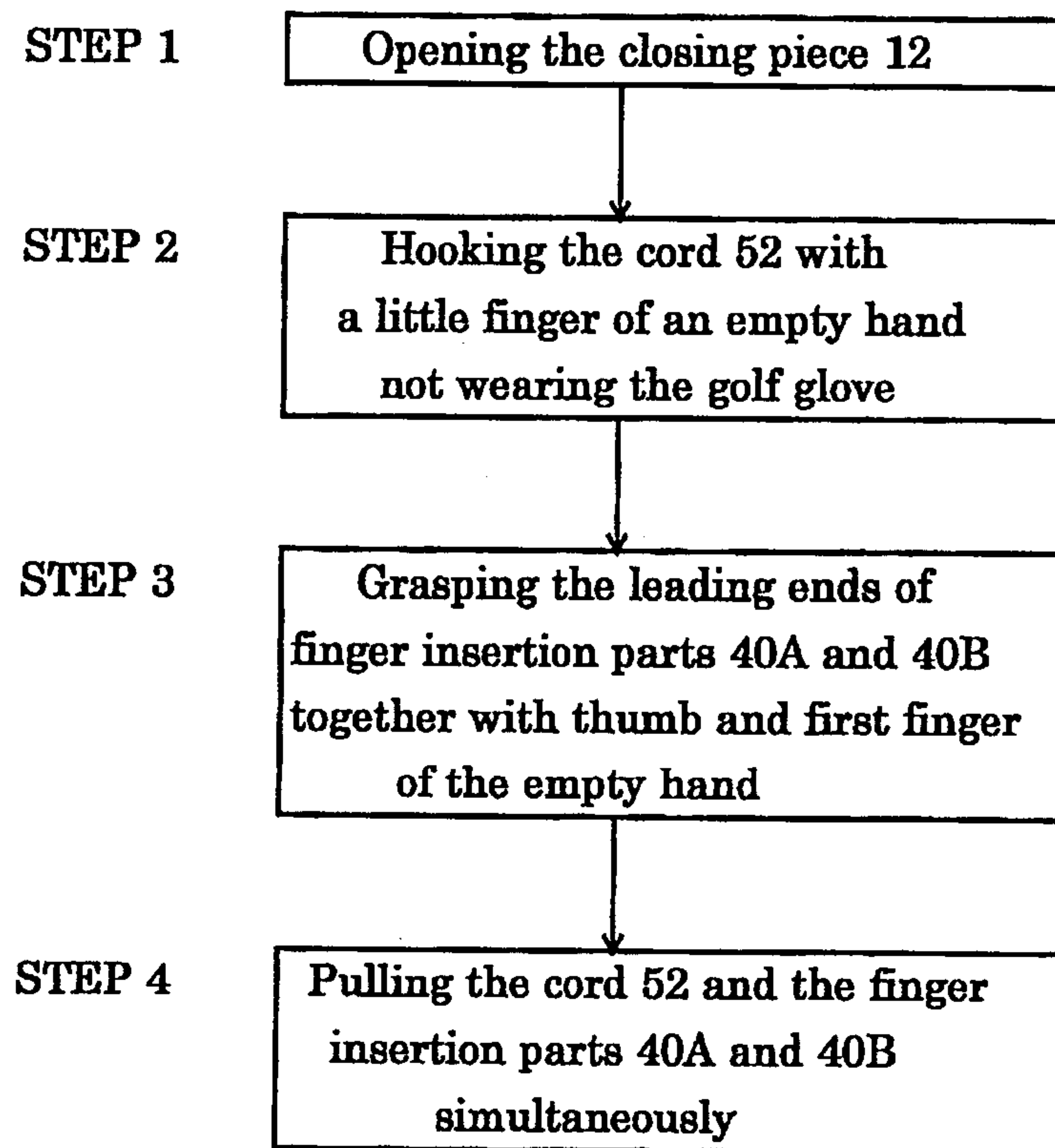

FIG. 6

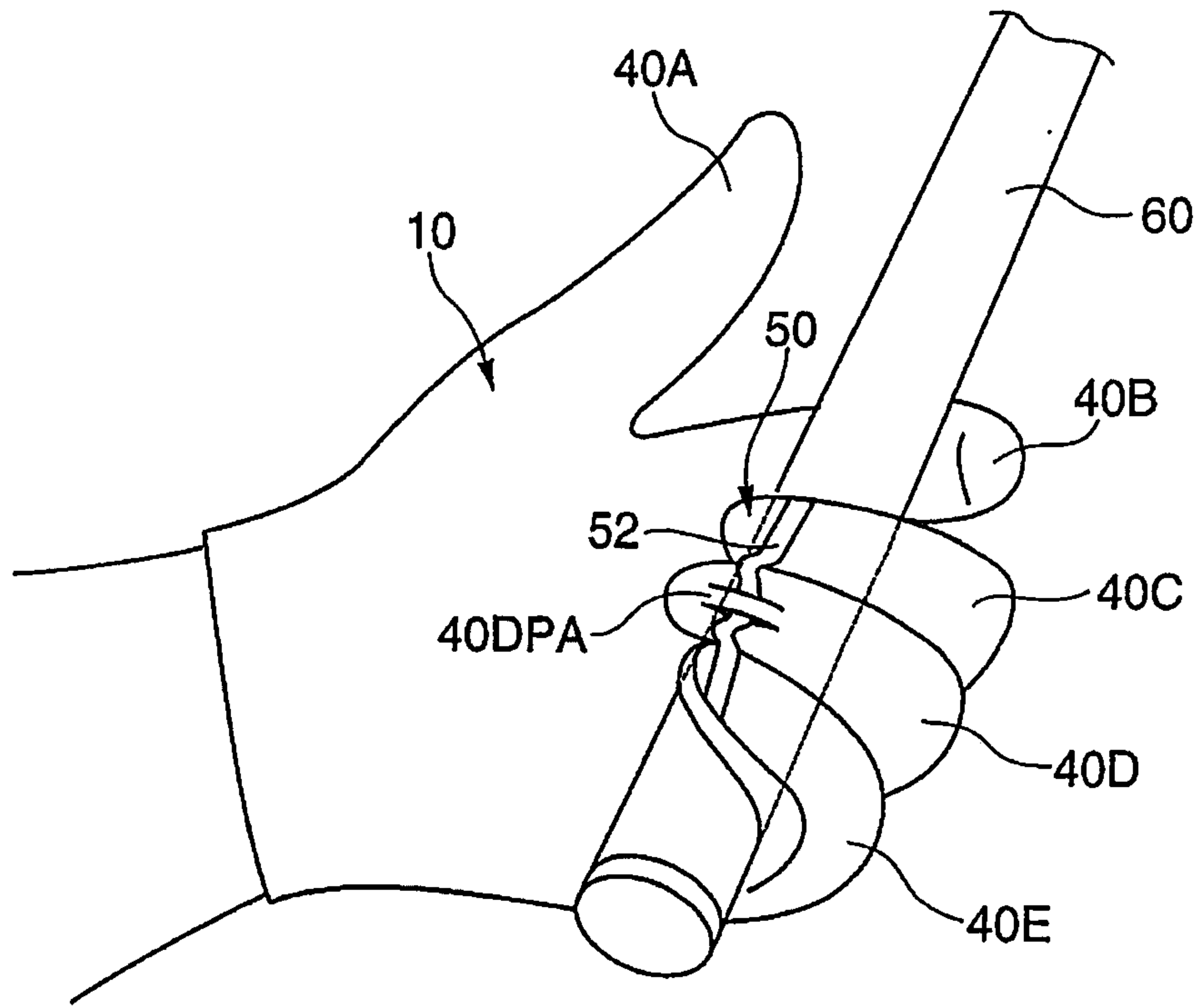

FIG. 7

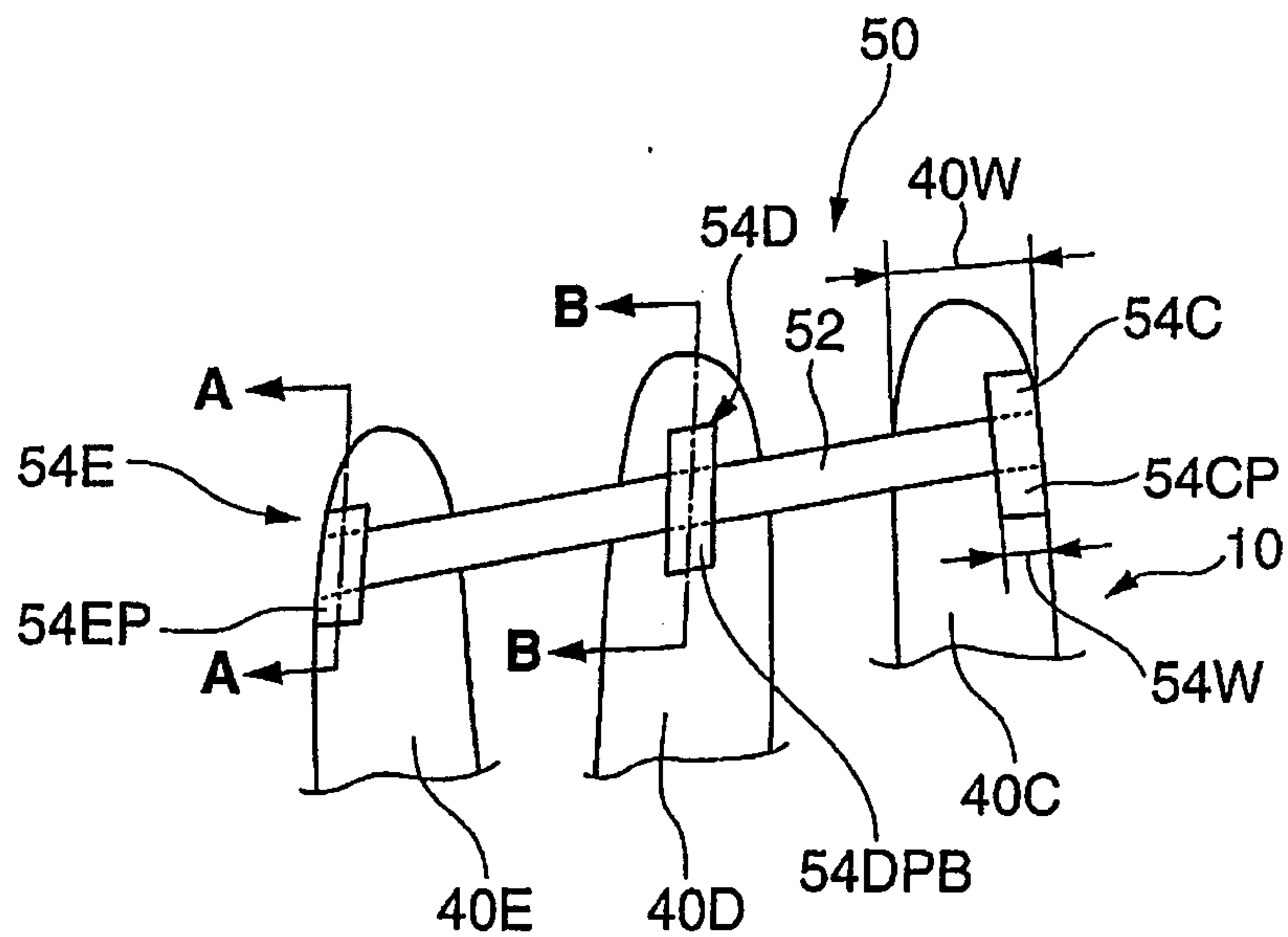
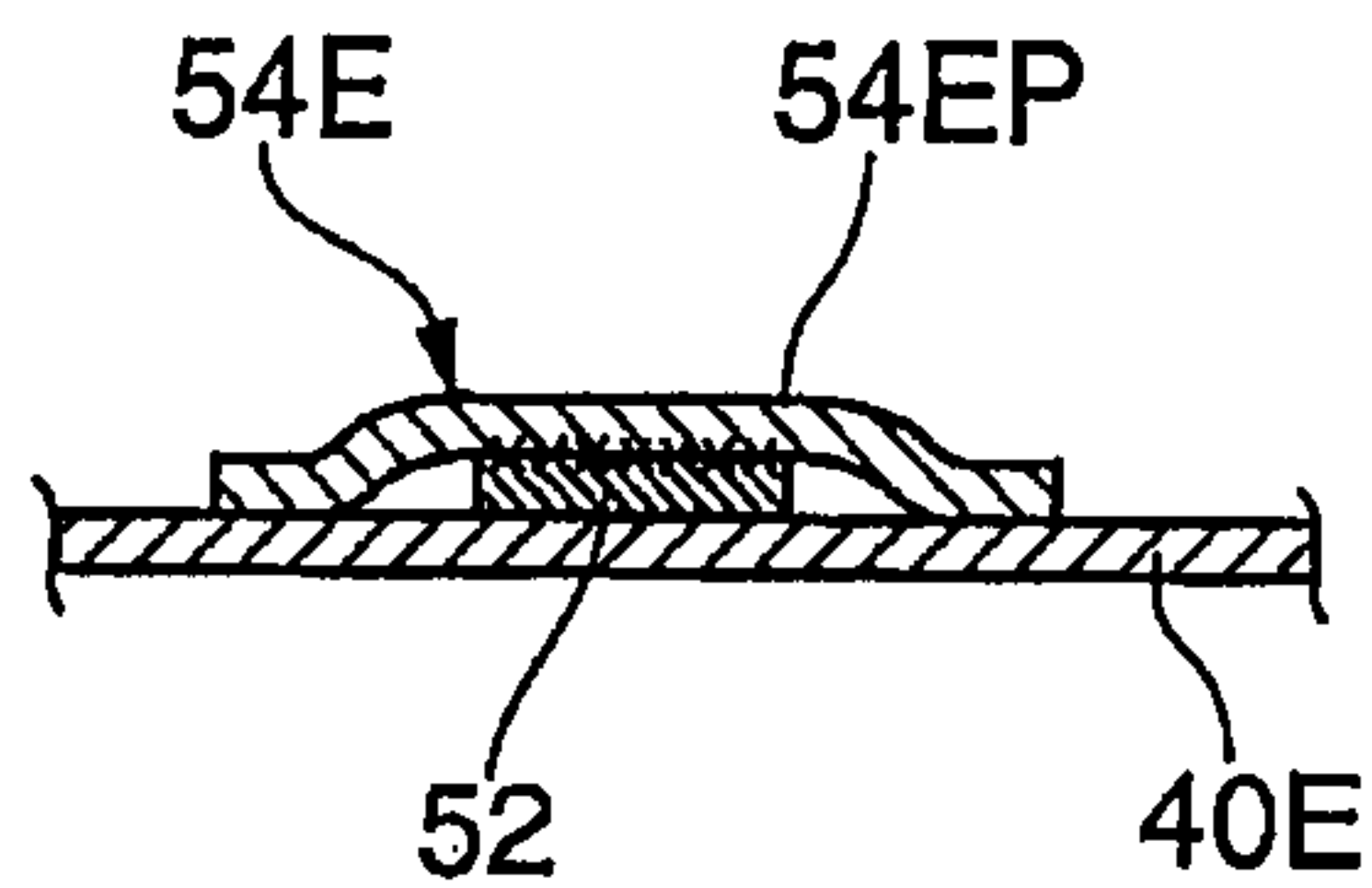

FIG. 8

(A)



(B)

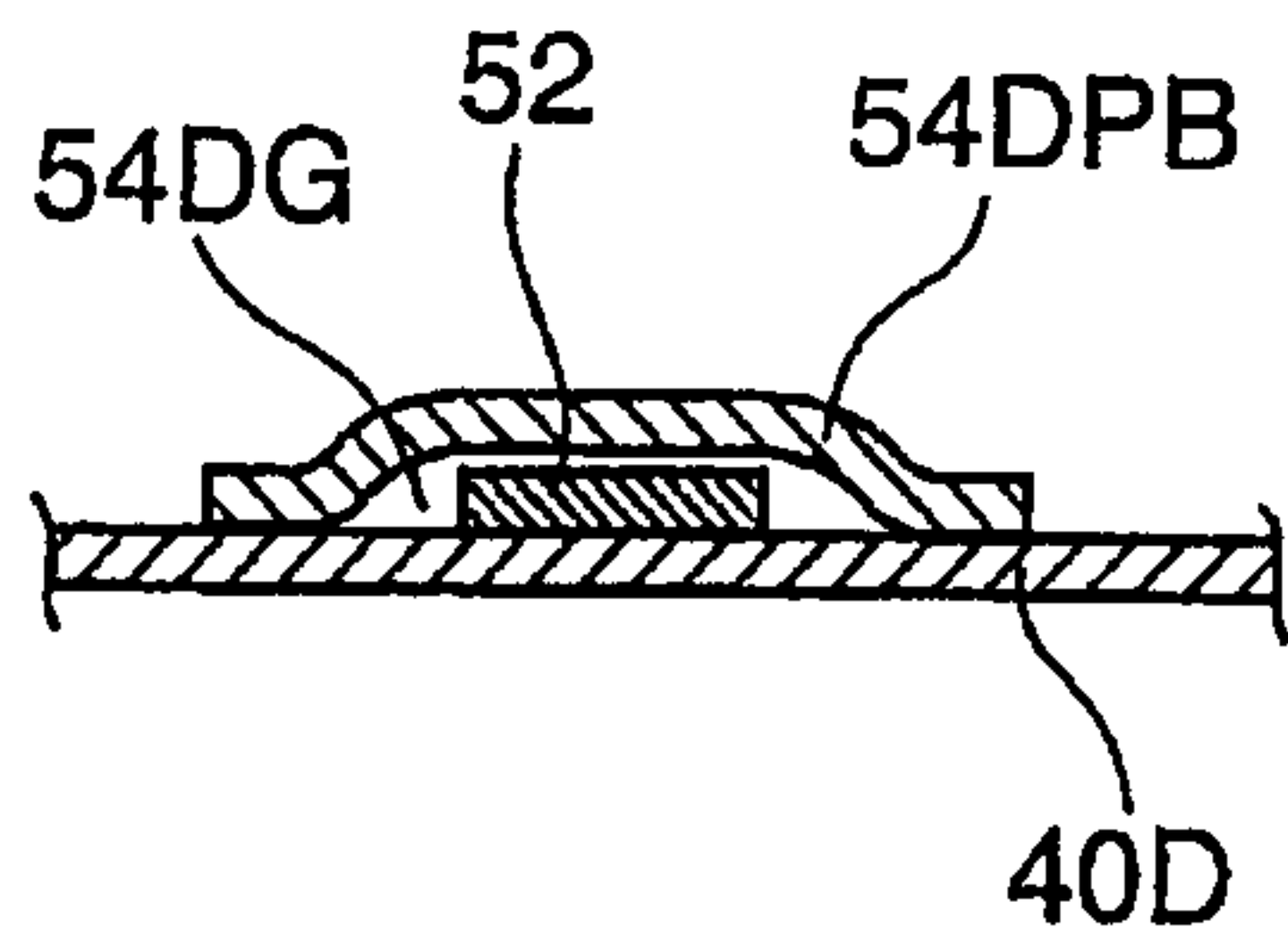

FIG. 9

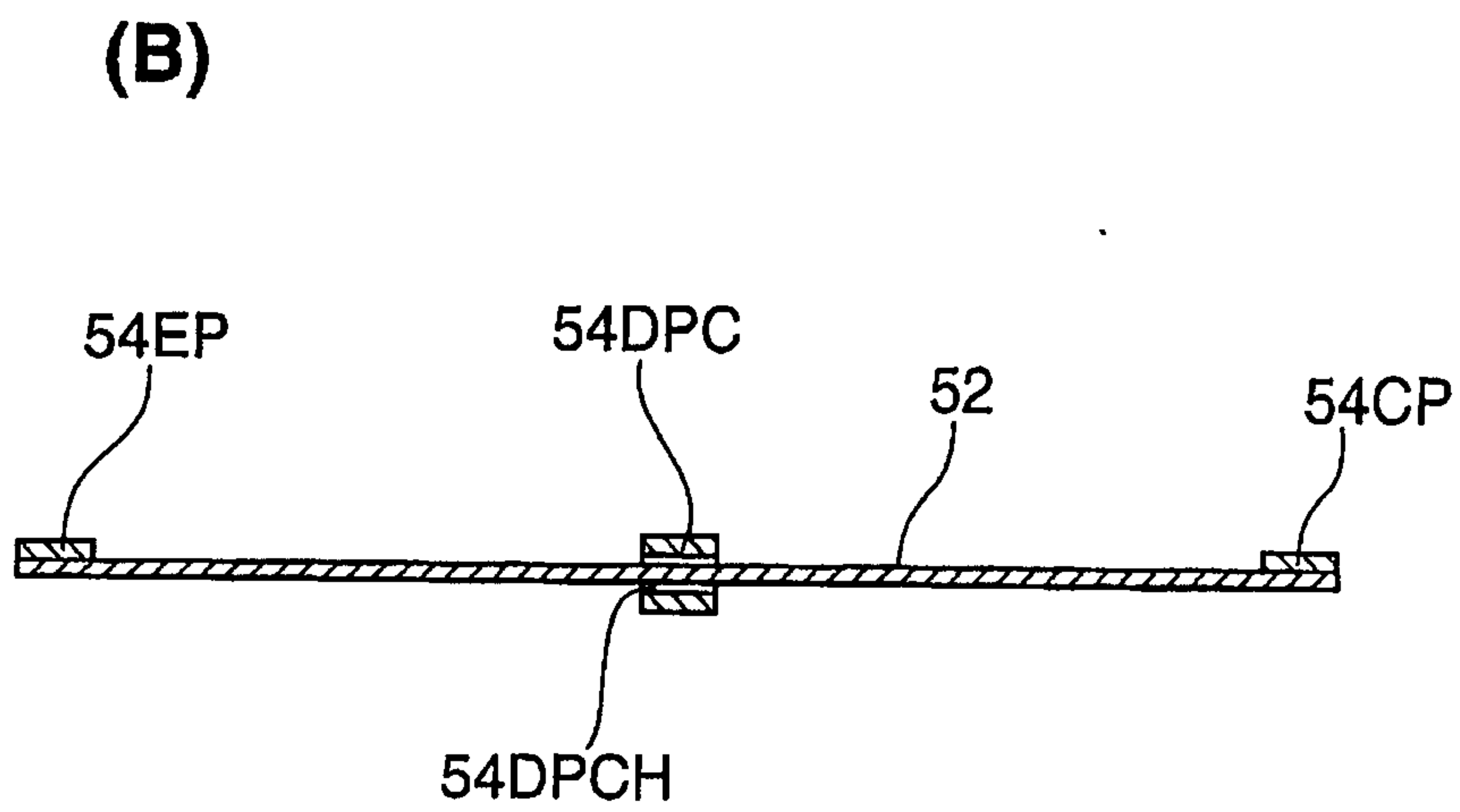
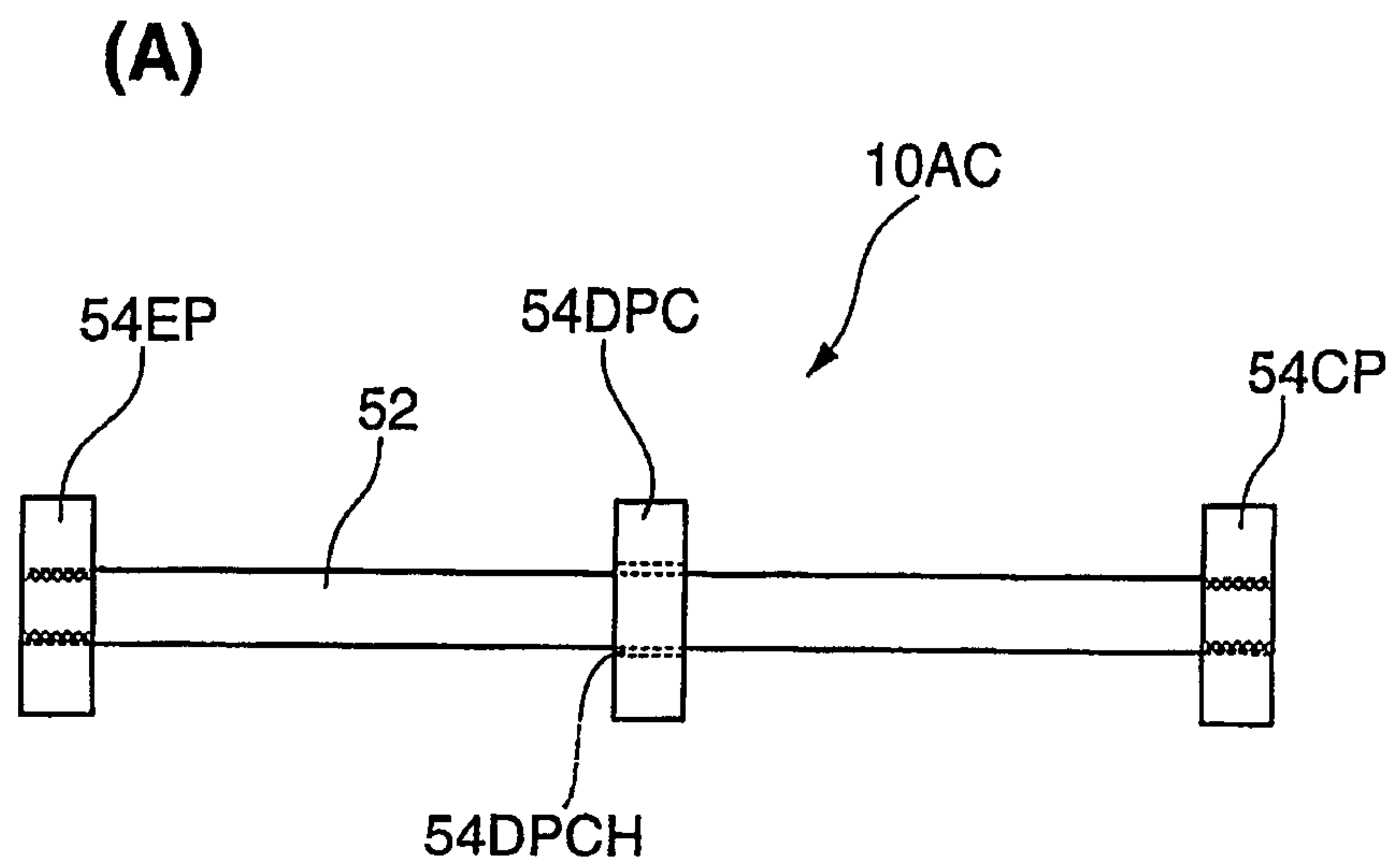

FIG. 1

