



(11) **EP 2 241 208 A1**

(12) **EUROPEAN PATENT APPLICATION**

(43) Date of publication:
20.10.2010 Bulletin 2010/42

(51) Int Cl.:
A43B 13/18 (2006.01) A43B 13/20 (2006.01)
A43B 13/36 (2006.01) A43B 21/42 (2006.01)

(21) Application number: **09177475.2**

(22) Date of filing: **30.11.2009**

(84) Designated Contracting States:
AT BE BG CH CY CZ DE DK EE ES FI FR GB GR HR HU IE IS IT LI LT LU LV MC MK MT NL NO PL PT RO SE SI SK SM TR
Designated Extension States:
AL BA RS

(71) Applicant: **FSC Co., Ltd.**
Gwangan-dong, Suyeong-gu
Busan 613-104 (KR)

(72) Inventor: **Kang, Hyung Chul**
617-011, Busan (KR)

(30) Priority: **16.04.2009 KR 20090033089**

(74) Representative: **Viering, Jentschura & Partner**
Grillparzerstrasse 14
81675 München (DE)

(54) **Sole for shoes enabling exchange of shock-absorbing member**

(57) Disclosed herein is a sole for shoes enabling exchange of a shock-absorbing member, in which a shock-absorbing member can be exchanged with one suited to each situation whenever necessary depending on the state of a wearer's feet, the condition of a road surface, the walking motion, or the like even in a state where a shoe has been manufactured and is worn by the wearer, thereby further improving convenience in use.

Since the shoe sole 100 includes the hollow space portion formed laterally at the inside thereof, any one selected from the group consisting of the air bag, the cushion member and the spring can be exchangeably employed as the shock-absorbing member so to be suited to each situation whenever necessary depending on the state of a wearer's feet, the condition of a road surface, the walking motion, or the like, thereby further improving convenience in use.

FIG1.

(b)

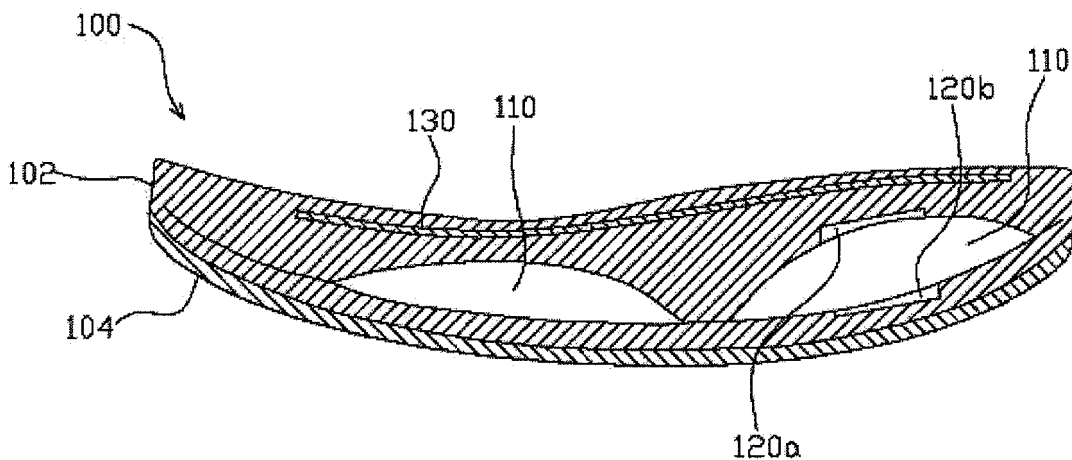

EP 2 241 208 A1

Description**BACKGROUND OF THE INVENTION****Field of the Invention**

[0001] The present invention relates to a sole for shoes enabling exchange of a shock-absorbing member, and more particularly, to such a sole for shoes enabling exchange of a shock-absorbing member, in which a shock-absorbing member can be exchanged with one suited to each situation whenever necessary depending on the state of a wearer's feet, the condition of a road surface, the walking motion, or the like even in a state where a shoe has been manufactured and is worn by the wearer, thereby further improving convenience in use.

Background of the Related Art

[0002] In general, the basic purpose of a sole for a shoe is to allow the sole for the shoe to be attached to a bottom surface of the upper portion of the shoe surrounding the top of a wearer's foot so that the sole of the wearer's foot does not come into direct contact with the road surface to protect the sole of the wearer's foot as well as reduce a fatigue feeling even during a long walk.

[0003] Recently, besides the basic purpose of the sole for the shoe, a functional sole for a shoe is used which is designed to protect the wearer's foot from an impact exerted thereto during the walk. As one example, a shock-absorbing member is embedded in a heel portion of the functional shoe sole so as to protect the wearer's foot from an impact occurring during the walk.

[0004] Since such a functional shoe sole includes a shock-absorbing member built therein, it has an advantage of making the wearer's walk comfortable. However, a representative example of the shock-absorbing member largely includes a cushion member made of a soft material, a spring and an air bag, each of which is built in a shoe sole or is formed integrally with the shoe sole, thus making it impossible to be separated from the shoe sole.

[0005] In the meantime, among the kinds of the shock-absorbing member, the cushion member is selected when a wearer wants a softer and more comfortable walk, the spring is selected when the wearer wants a lighter walk due to good resiliency, and the air bag is selected when the wearer wants a walk giving a cushioning feeling of an intermediate level of the more comfortable walk and the lighter walk.

[0006] In order for the wearer to wear the shoes to be suited to each situation, at least three pair of shoes is needed. Disadvantageously, this causes the waste of cost according to the purchase of several pair of shoes as well as considerable evils when kept in custody.

SUMMARY OF THE INVENTION

[0007] Therefore, the present invention has been made in view of the above problems occurring in the prior art, and it is an object of the present invention to provide a sole for shoes enabling exchange of a shock-absorbing member, in which a shock-absorbing member can be exchanged with one suited to each situation whenever necessary depending on the state of a wearer's feet, the condition of a road surface, the walking motion, and the like even in a state where a shoe has been manufactured and is worn by the wearer, thereby further improving convenience in use.

[0008] In order to accomplish the above object, the present invention provides a sole for shoes enabling exchange of a shock-absorbing member, the shoe sole being attached to a bottom surface of the upper portion of the shoe surrounding the top of a wearer's foot, and including at least one hollow space portion formed laterally at the inside of the shoe sole in such a fashion as to penetrate to the left and right sides, and a pair of opposed seating recesses formed on the ceiling surface and the bottom surface of the hollow spacing portion so as to prevent the escape of the shock-absorbing member exchangeably inserted into the hollow space portion, whereby the shock-absorbing member is inserted into the hollow space portion so as to absorb an impact exerted to the shoes during a walk such that it is exchangeable with one suited to each situation whenever necessary depending on the state of a wearer's feet, the condition of a road surface, the walking motion, or the like.

[0009] Preferably, the shock-absorbing member is any one selected from the groups consisting of an air bag, a spring and a cushion member.

BRIEF DESCRIPTION OF THE DRAWINGS

[0010] FIG. 1(a) is a schematic longitudinal side view illustrating a sole for shoes enabling exchange of a shock-absorbing member according to a preferred embodiment of the present invention, and FIG. 1(b) is a schematic longitudinal cross-sectional view of FIG. 1(a);

[0011] FIG. 2(a) to 2(c) are perspective views illustrating a shock-absorbing member according to a preferred embodiment of the present invention;

[0012] FIG. 3(a) to (3c) are schematic longitudinal side views illustrating a state where a sole for shoes enabling exchange of a shock-absorbing member is in use according to a preferred embodiment of the present invention;

[0013] FIG. 4 is a view illustrating a process of manufacturing a sole for shoes enabling exchange of a shock-absorbing member according to a preferred embodiment of the present invention;

[0014] FIG. 5 is a view illustrating a process of manufacturing a sole for shoes enabling exchange of a shock-absorbing member according to another preferred embodiment of the present invention;

[0015] FIG. 6 is a view illustrating a process of manu-

facturing a sole for shoes enabling exchange of a shock-absorbing member according to yet another preferred embodiment of the present invention; and

[0016] FIG. 7 is a view illustrating a process of manufacturing a sole for shoes enabling exchange of a shock-absorbing member according to still another preferred embodiment of the present invention.

DETAILED DESCRIPTION OF THE PREFERRED EMBODIMENT

[0017] A sole for shoes enabling exchange of a shock-absorbing member according to the preferred embodiments of the invention will be hereinafter described in more detail with reference to the accompanying drawings.

[0018] Terms and words used in this specification and claims should not be construed as a typical or dictionary meaning, but should be interpreted as the meaning and concept conforming to the technical idea of the present invention based on the principle that the inventor can properly define the concept of the terms to explain the inventor's invention in the best way.

[0019] Therefore, it is to be noted that the constructions described in the embodiments in this specification and shown in the accompanied drawings are merely most preferred embodiments of the present invention, but not cover all the technical spirits of the present invention, and hence various equivalents and modifications capable of replacing the constructions may exist at the time point of application.

[0020] FIG. 1(a) is a schematic longitudinal side view illustrating a sole for shoes enabling exchange of a shock-absorbing member according to a preferred embodiment of the present invention, and FIG. 1(b) is a schematic longitudinal cross-sectional view of FIG. 1(a), and FIG. 2(a) to 2(c) are perspective views illustrating a shock-absorbing member according to a preferred embodiment of the present invention.

[0021] First, referring to FIG. 1, a sole 100 for shoes enabling exchange of a shock-absorbing member of the present invention includes a hollow space portion 110 formed laterally at the inside thereof in such a fashion as to penetrate to the left and right sides. The number of the hollow space portions 110 formed is at least one, and preferably the hollow space portion 110 is formed at the ball portion and the heel portion of the shoe sole, respectively. Also, when the hollow space portion 110 is formed in an elliptical shape rather than a circular shape, the overall dimension thereof will increase and will be more stable.

[0022] In addition, the hollow space portion 110 has a pair of opposed seating recesses 120a and 120b formed on the ceiling surface and the bottom surface thereof, respectively, so as to prevent a shock-absorbing member 200, which will be described, from escaping from the hollow space portion.

[0023] Moreover, the shoe sole 100 includes a shank

130 embedded in the upper inner portion thereof so as to maintain the shape thereof and have an excellent shape-restoring force. The shank 130 is typically widely used, and thus a separate description thereof will be omitted to avoid redundancy.

[0024] Meanwhile, the shoe sole 100 includes a midsole 102 made of a soft material, and an outsole 104 attached to the bottom surface of the midsole 102 so as to come into direct contact with a ground surface and made of a material which is harder than that of the midsole 102 so that the hollow space portion 110 can be laterally formed at the inside of the midsole. Alternatively, it should be understood that the midsole 102 and the outsole 104 are made of the same material so that the hollow space portion 110 can be laterally formed at the inside of the midsole so as not to specially divide the midsole 102 and the outsole 104.

[0025] A shock-absorbing member 200 is exchangeably inserted into the hollow space portion 110 formed laterally at the inside of the shoe sole 100 as constructed above so as to absorb an impact exerted to the shoes during a walk. Referring to FIG. 2, there are shown a group of the shock-absorbing members 200 inserted into the hollow space portion 110.

[0026] That is, the shock-absorbing member 200 of the present invention includes the group consisting of an air bag 210, a spring 220 and a cushion member 230 made of a soft material, which are sequentially shown in FIG. 2(a) to 2(c). Any one selected, as the shock-absorbing member 200, from the group consisting of the air bag 210, the spring 220 and the cushion member 230 is inserted into the hollow space portion 110.

[0027] For example, the cushion member 230 is selected and inserted into the shock-absorbing member 200 when a wearer wants a softer and more comfortable walk, the spring 220 is selected and inserted into the shock-absorbing member 200 when the wearer wants a lighter walk due to good resiliency, and the air bag 210 is selected and inserted into the shock-absorbing member 200 when the wearer wants a walk giving a cushioning feeling of an intermediate level of the more comfortable walk and the lighter walk.

[0028] In this case, the inside of the air bag 210 is filled with air, and the air bag 210 is preferably formed in the shape of a bellows tube so that it is seated in the pair of opposed seating recesses 120a and 120b formed on the ceiling surface and the bottom surface of the hollow space portion 110 so as to prevent the air bag from easily escaping from the hollow space portion 110.

[0029] Unlike the conventional prior art, in the present invention, the shoe sole 100 and the shock-absorbing member 200 are manufactured separately so that the shock-absorbing member 200 can be exchanged whenever necessary, which will be described hereinafter.

[0030] FIG. 3(a) to 3(c) are schematic longitudinal side views illustrating a state where a sole for shoes enabling exchange of a shock-absorbing member is in use according to a preferred embodiment of the present invention;

[0031] First, referring to FIG. 3(a), the shoe sole 100 enabling exchange of the shock-absorbing member 200 is attached to the bottom surface of the upper portion 140 of the shoes, and the cushion member 230 made of a soft material is inserted into the hollow space portion 110 formed laterally at the inside of the shoe sole 100. That is, when a pedestrian wants a cozier and more comfortable walk, he or she inserts the cushion member 230 into the hollow space portion 110.

[0032] When the pedestrian wants a lighter walk depending on the condition of the road surface or the walking motion while walking through the shoe sole 100 inserted with the cushion member 230, he or she pushes the cushion member 230 in one direction to remove it from the shoe sole, and then inserts the spring 220 having an excellent resiliency into the hollow space portion 110 as shown in FIG. 3(b).

[0033] In this case, in order to more stably insert the spring 220, it is required that the spring 220 should be inserted into the hollow space portion 110 in such a fashion that the spring is seated in the opposed seating recesses 120a and 120b formed on the ceiling surface and the bottom surface of the hollow space portion 110.

[0034] In this manner, when the spring 220 is inserted into the hollow space portion 110 of the shoe sole 100, the pedestrian will be able to enjoy a lighter walk owing to resiliency of the spring 220.

[0035] When the wearer wants a walk giving a cushioning feeling of an intermediate level of the more comfortable walk and the lighter walk depending on the state of the wearer's feet or the condition of a road surface, he or she pushes the spring 220 in one direction to remove it from the shoe sole, and then inserts the air bag 210 into the hollow space portion 110 as shown in FIG. 3(c). Of course, the air bag 210 is preferably seated in the opposed seating recesses 120a and 120b formed on the ceiling surface and the bottom surface of the hollow space portion 110.

[0036] In the meantime, in the case where two hollow space portions 110 are formed laterally at the inside of the shoe sole 100, the spring is inserted into one-side hollow space portion 110 and the cushion member 230 is inserted into the other-side hollow space portion 110 as shown in FIG. 2(b), so that the shoe sole can be implemented to provide different cushioning feelings to the ball portion and the heel portion thereof. Like this, not a manufacturer side but a wearer side can use the shock-absorbing member 200 suited to himself or herself and can exchange it whenever necessary depending on the situations.

[0037] That is, it is preferable to select and use the cushion member 230 excellent in a cushioning feeling or the air bag 210 as the shock-absorbing member in a state where the wearer suffers from foot fatigue or at a place where a road surface is irregular and uneven. Also, it is preferable to select and use the spring 220 as the shock-absorbing member when the road surface is regular and even or the wearer wants to take exercise. Of course,

the selection of the shock-absorbing member is arbitrarily determined by a user, and is not limited thereto.

Resultantly, since the sole 100 for shoes enabling exchange of a shock-absorbing member according to the present invention includes the hollow space portion 110 formed laterally at the inside thereof, any one selected from the group consisting of the air bag 210, the cushion member 230 and the spring 220, which have an impact absorbing force or give a cushioning feeling, can be exchangeably employed as the shock-absorbing member 200 so to be suited to each situation whenever necessary depending on the state of a wearer's feet, the condition of a road surface, the walking motion, or the like, thereby further improving convenience in use.

[0038] Besides, since shoes having different shock-absorbing forces can be implemented using a pair of shoes, it is possible to achieve a greater economic advantage.

[0039] A process of manufacturing the sole 100 for shoes enabling exchange of a shock-absorbing member having the above-mentioned construction and operation will be described hereinafter.

[0040] FIG. 4 is a view illustrating a process of manufacturing a sole for shoes enabling exchange of a shock-absorbing member according to a preferred embodiment of the present invention, FIG. 5 is a view illustrating a process of manufacturing a sole for shoes enabling exchange of a shock-absorbing member according to another preferred embodiment of the present invention, FIG. 6 is a view illustrating a process of manufacturing a sole for shoes enabling exchange of a shock-absorbing member according to yet another preferred embodiment of the present invention, and FIG. 7 is a view illustrating a process of manufacturing a sole for shoes enabling exchange of a shock-absorbing member according to still another preferred embodiment of the present invention.

[0041] First, referring to FIG. 4, the shoe sole 100 according to the present invention is manufactured by being foam-molded integrally through a molding step (s100) in such a fashion as to have the hollow space portion 110 formed laterally at the inside thereof so as penetrate to the left and right sides and having a pair of opposed seating recesses 120a and 120b formed on the ceiling surface and the bottom surface of the hollow space portion. That is, when the shoe sole 100 is formed, the midsole and the outsole are made of the same material without being divided separately. Any one selected from the aforementioned exemplary group of the shock-absorbing member 200 is exchangeably inserted into the hollow space portion 110 of the thus formed shoe sole.

[0042] Next, referring to FIG. 5, there is shown a process of manufacturing the shoe sole 100 according to another preferred embodiment of the present invention.

[0043] The process of manufacturing the shoe sole 100 includes: a first molding step (s110) of foam-molding the midsole 102 having the hollow space portion 110 formed laterally at the inside thereof so as penetrate to the left and right sides and having a pair of opposed seat-

ing recesses 120a and 120b formed on the ceiling surface and the bottom surface of the hollow space portion; a second molding step (s120) of foam-molding the outsole 104 using a material identical to or different from that of the midsole 102; and an attaching step (s130) of attaching the outsole 104 to the bottom surface of the midsole 102. Any one selected from the aforementioned exemplary group of the shock-absorbing member 200 is exchangeably inserted into the hollow space portion 110 of the thus manufactured shoe sole 100.

[0044] Subsequently, referring to FIG. 6, there is shown a process of manufacturing the shoe sole 100 according to yet another preferred embodiment of the present invention.

[0045] The process of manufacturing the shoe sole 100 includes: a first molding step (s110') of foam-molding a first midsole 102a having a concaved portion 106 which is opened at the left and right sides thereof and at the bottom thereof, has a seating recess 120a formed on the ceiling surface thereof and is formed in a semi-spherical or semi-elliptical shape; a second molding step (s120') of sequentially foam-molding a midsole 102b and an outsole 104 using a material identical to or different from that of the first midsole 102a in such a fashion that a seating recess 120b is formed on the top surface of the second midsole 102b so as to be opposed to the seating recess 120a; an attaching molding step (s130) of attaching the second midsole 102b to the bottom surface of the first midsole 102a so as to allow a hollow space portion 110 to be defined between the first midsole 102a and the second midsole 102b in a semi-spherical or semi-elliptical shape in such a fashion as to be laterally penetrate to the left and the right sides. Similarly, any one selected from the aforementioned exemplary group of the shock-absorbing member 200 is exchangeably inserted into the hollow space portion 110 of the thus manufactured shoe sole 100.

[0046] Last, referring to FIG. 7, there is shown a process of manufacturing the shoe sole 100 according to still another preferred embodiment of the present invention.

[0047] The process of manufacturing the shoe sole 100 includes: a first molding step (s110') of foam-molding a first midsole 102a having a concaved portion 106 which is opened at the left and right sides thereof and at the bottom thereof, has a seating recess 120a formed on the ceiling surface thereof and is formed in a semi-spherical or semi-elliptical shape; a second molding step (s120'') of foam-molding a midsole 102b using a material identical to or different from that of the first midsole 102a in such a fashion that a seating recess 120b is formed on the top surface of the second midsole 102b so as to be opposed to the seating recess 120a form on the first midsole 102a; a third molding step (s140) of foam-molding an outsole 104 using a material identical to or different from that of the first midsole 102a; and an attaching molding step (s130) of attaching the second midsole 102b to the bottom surface of the first midsole 102a so as to allow a hollow space portion 110 to be defined between the first

midsole 102a and the second midsole 102b in a semi-spherical or semi-elliptical shape in such a fashion as to be laterally penetrate to the left and the right sides, to thereby complete a midsole 102, and simultaneously attaching the outsole 104 to the bottom surface of the second midsole 102b. Similarly, any one selected from the aforementioned exemplary group of the shock-absorbing member 200 is exchangeably inserted into the hollow space portion 110 of the thus manufactured shoe sole 100.

[0048] Finally, the sole 100 for shoes enabling exchange of a shock-absorbing member according to the present invention may be integrally manufactured without separately dividing the midsole 102 and the outsole 104, and may be manufactured by separately dividing the midsole 102 and the outsole 104. Alternatively, the shoe sole 100 may be manufactured in such a fashion that the midsole 102 is divided into two sections. Therefore, it is to be noted that the shoe sole 100 can be manufactured in various manners.

Thus, whatever manners are used to manufacture the shoe sole 100 according to the present invention, the shoe sole 100 includes the hollow space portion 110 formed laterally at the inside thereof. Also, the shoe sole 100 is constructed such that any one selected from the group consisting of the air bag 210, the spring 220 and the cushion member 230 is exchangeably inserted into the shock-absorbing member 200 as the shock-absorbing member whenever necessary.

[0049] As described above, according to the present invention, since the sole 100 for shoes enabling exchange of a shock-absorbing member according to the present invention includes the hollow space portion formed laterally at the inside thereof, any one selected from the group consisting of the air bag, the cushion member and the spring, which have an impact absorbing force or give a cushioning feeling, can be exchangeably employed as the shock-absorbing member so to be suited to each situation whenever necessary depending on the state of a wearer's feet, the condition of a road surface, the walking motion, or the like, thereby further improving convenience in use.

[0050] Besides, since shoes having different shock-absorbing forces can be implemented using a pair of shoes, it is possible to achieve a greater economic advantage.

[0051] As mentioned above, the features and the technical advantages of the present invention have been somewhat broadly described in order to more fully understand the claims which will be later. Additional features and advantages constituting the claims of the present invention will be described hereinafter. It should be understood by those having ordinary skill in the art that the concept and specific embodiments disclosed in the present invention can be immediately used as a basis of design or modification of other structures for performing a similar object to that of the present invention.

[0052] In addition, an equivalent structure changed or

modified by those having ordinary skill in the art using the concept and specific embodiments disclosed in the present invention as a basis of design or modification of other structures for performing the same object as that of the present invention can be changed, substituted or modified variously without departing from the scope and spirit of the present invention described in the claims. 5

Claims 10

1. A sole for shoes enabling exchange of a shock-absorbing member, the shoe sole being attached to a bottom surface of the upper portion of the shoe surrounding the top of a wearer's foot, **characterized in that** at least one hollow space portion is formed laterally at the inside of the shoe sole in such a fashion as to penetrate to the left and right sides, and a pair of opposed seating recesses is formed on the ceiling surface and the bottom surface of the hollow spacing portion so as to prevent the escape of the shock-absorbing member exchangeably inserted into the hollow space portion, 15
whereby the shock-absorbing member is inserted into the hollow space portion so as to absorb an impact exerted to the shoes during a walk such that it is exchangeable with one suited to each situation whenever necessary depending on the state of a wearer's feet, the condition of a road surface, the walking motion, or the like. 20
25
30
2. The sole for shoes according to claim 1, wherein the shock-absorbing member is any one selected from the group consisting of an air bag, a spring and a cushion member. 35

40

45

50

55

FIG1.

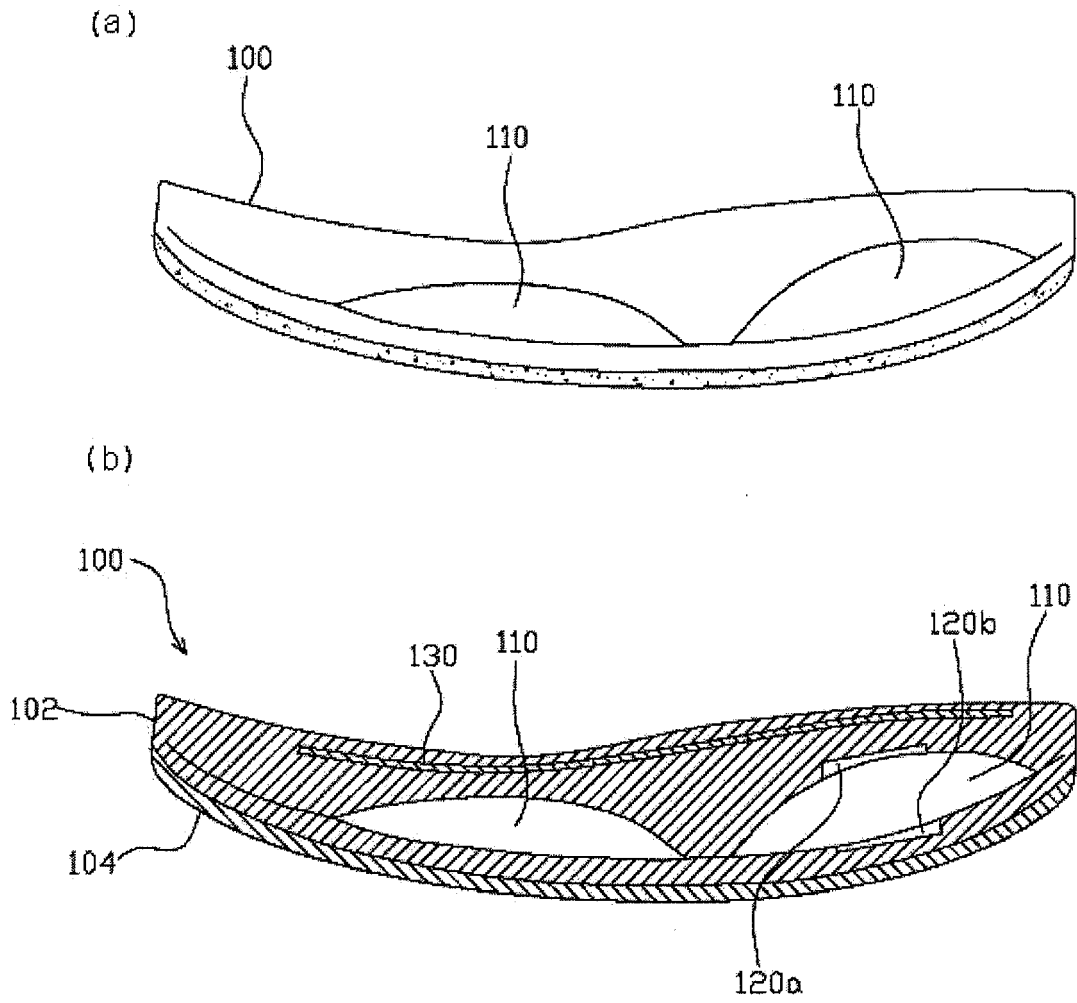

FIG2.

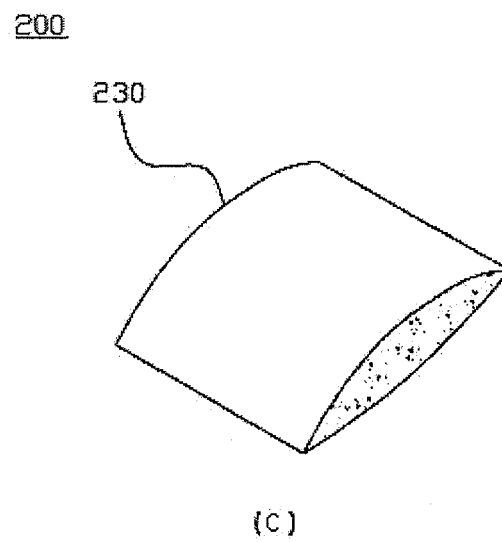
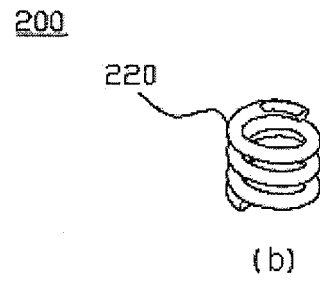
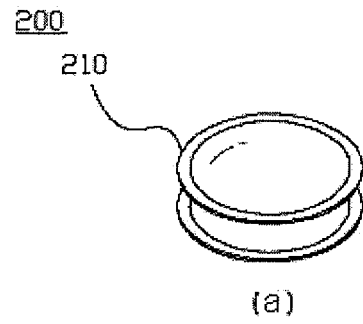

FIG3.

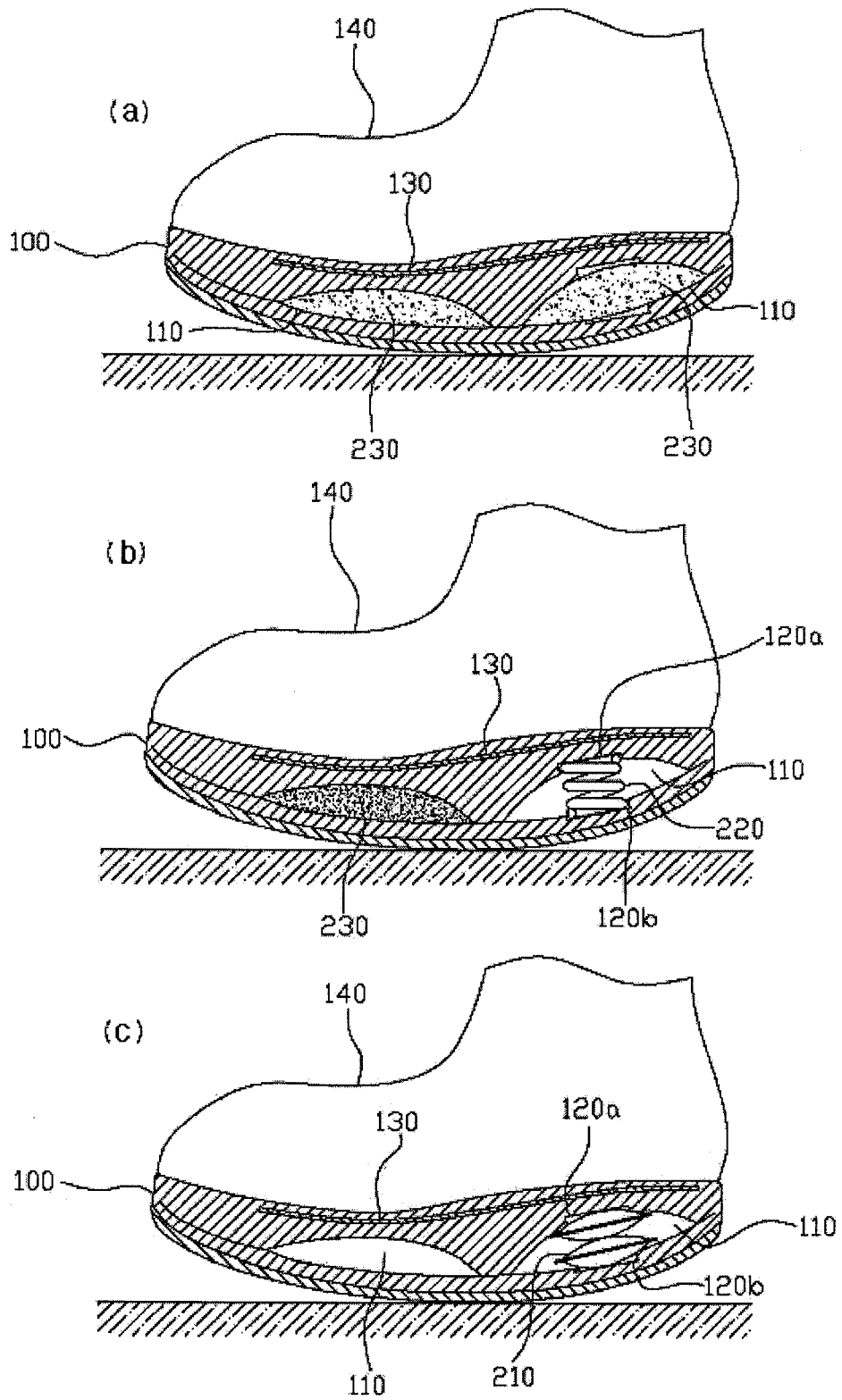

FIG4.

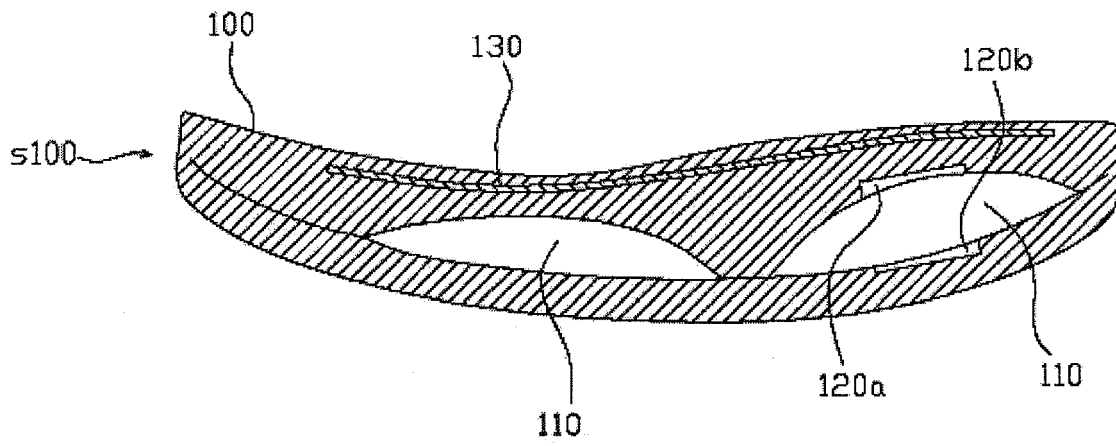

FIG5.

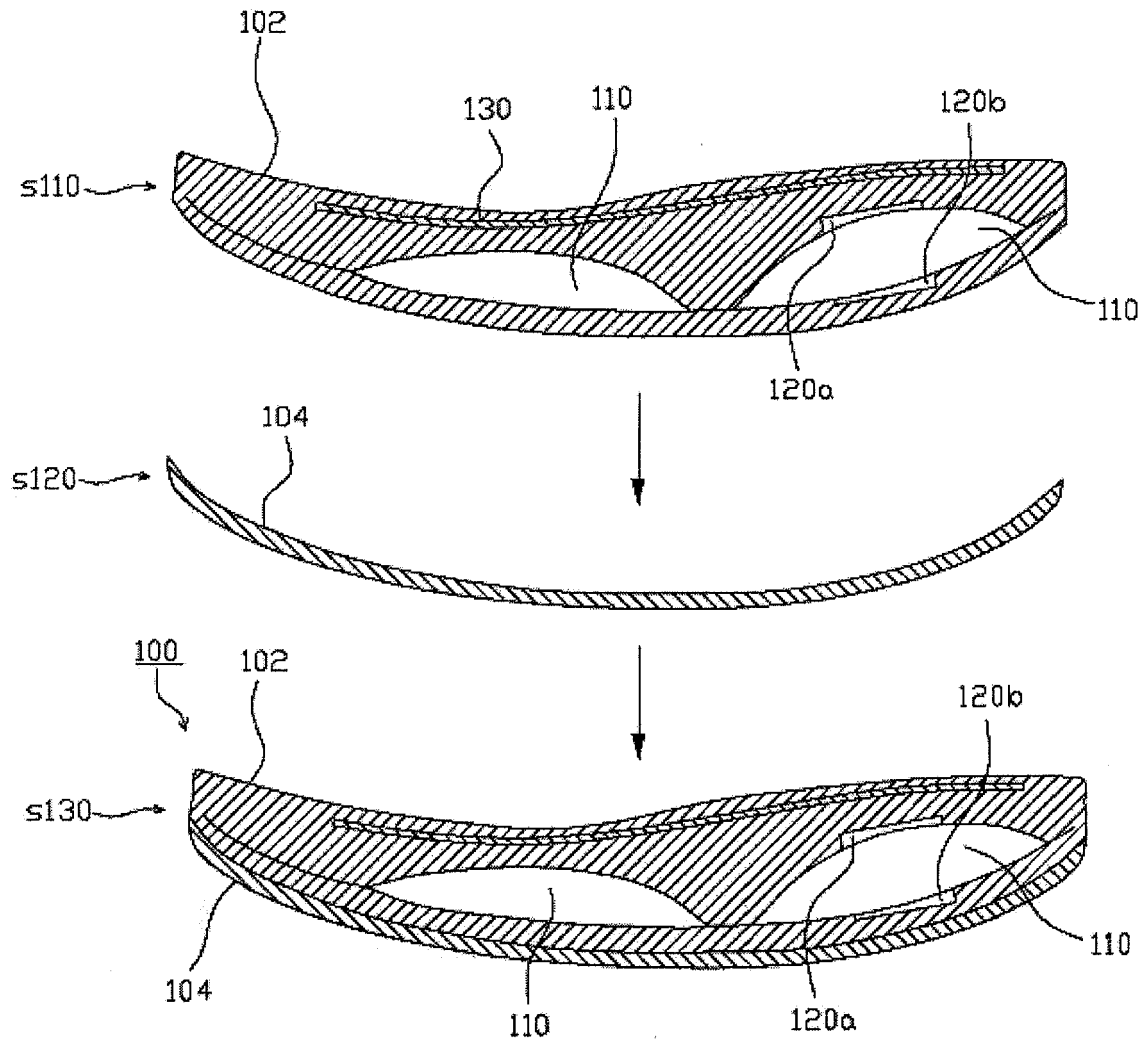

FIG6.

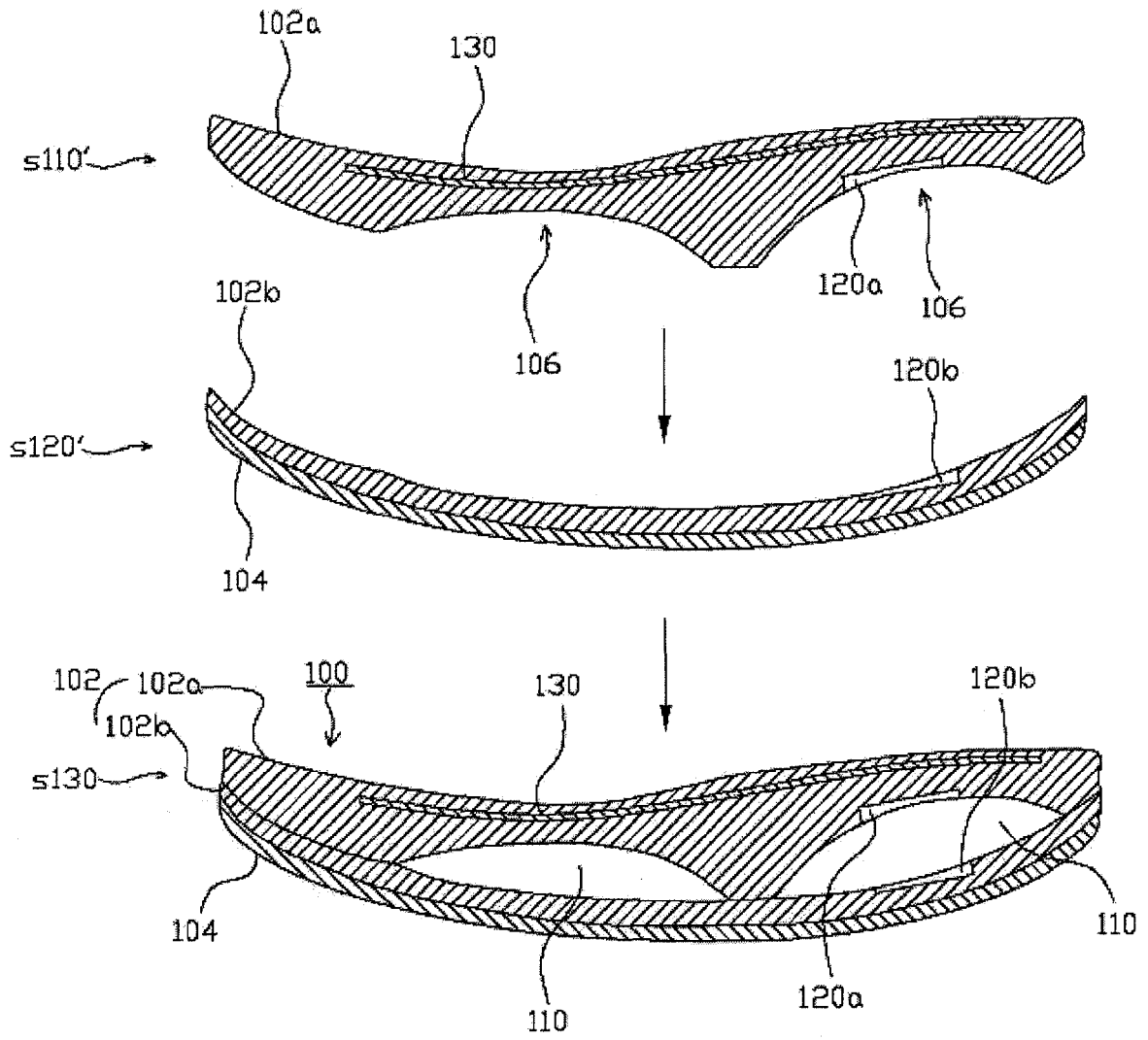
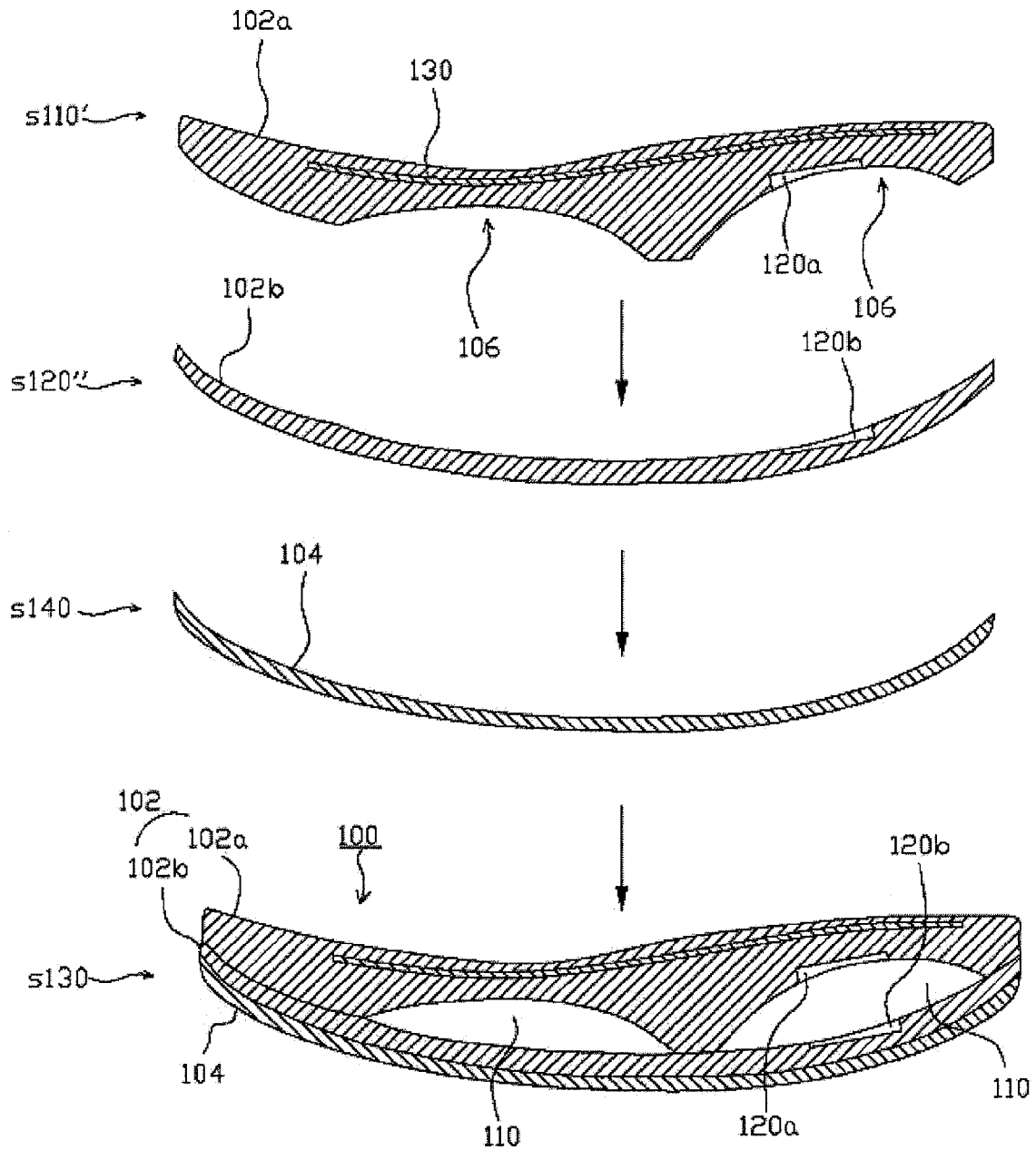

FIG. 7.





EUROPEAN SEARCH REPORT

 Application Number
 EP 09 17 7475

DOCUMENTS CONSIDERED TO BE RELEVANT			
Category	Citation of document with indication, where appropriate, of relevant passages	Relevant to claim	CLASSIFICATION OF THE APPLICATION (IPC)
X	WO 2007/113595 A2 (C & J CLARK INTERNAT LTD [GB]; TOWNS CHRIS [GB]) 11 October 2007 (2007-10-11) * page 8, paragraph 3 - page 9, paragraph 4; figures 10-14 *	1,2	INV. A43B13/18 A43B13/20 A43B13/36 A43B21/42
A	WO 2006/065047 A1 (LEE HO-HYOUNG [KR]) 22 June 2006 (2006-06-22) * pages 6-9; figures *	1,2	
A	US 2008/189986 A1 (ELNEKAVEH ALEXANDER [US]) 14 August 2008 (2008-08-14) * columns 24-29; figures 1,4 *	1,2	
A	WO 2008/050090 A1 (MAUNDER KEITH ALEXANDER DEREK [GB]) 2 May 2008 (2008-05-02) * page 5, lines 15-19; claim 9; figure *	1,2	
A	WO 2005/060781 A1 (DASSLER PUMA SPORTSCHUH [DE]; LACEY BRAD [GB]) 7 July 2005 (2005-07-07) * page 6, last paragraph - page 8, last paragraph; figure 1 *	1,2	
			TECHNICAL FIELDS SEARCHED (IPC)
			A43B
The present search report has been drawn up for all claims			
Place of search		Date of completion of the search	Examiner
Munich		19 July 2010	Vesin, Stéphane
CATEGORY OF CITED DOCUMENTS			
X : particularly relevant if taken alone Y : particularly relevant if combined with another document of the same category A : technological background O : non-written disclosure P : intermediate document		T : theory or principle underlying the invention E : earlier patent document, but published on, or after the filing date D : document cited in the application L : document cited for other reasons & : member of the same patent family, corresponding document	

2

EPO FORM 1503 03.82 (P04C01)

**ANNEX TO THE EUROPEAN SEARCH REPORT
ON EUROPEAN PATENT APPLICATION NO.**

EP 09 17 7475

This annex lists the patent family members relating to the patent documents cited in the above-mentioned European search report. The members are as contained in the European Patent Office EDP file on
The European Patent Office is in no way liable for these particulars which are merely given for the purpose of information.

19-07-2010

Patent document cited in search report	Publication date	Patent family member(s)	Publication date
WO 2007113595 A2	11-10-2007	NONE	
WO 2006065047 A1	22-06-2006	EP 1824353 A1 JP 2008523882 T US 2009056165 A1	29-08-2007 10-07-2008 05-03-2009
US 2008189986 A1	14-08-2008	WO 2008100575 A2	21-08-2008
WO 2008050090 A1	02-05-2008	NONE	
WO 2005060781 A1	07-07-2005	AT 400201 T DE 20320091 U1 DK 1699312 T3 EP 1699312 A1 ES 2310297 T3 JP 4191222 B2 JP 2007533332 T PT 1699312 E US 2006283044 A1	15-07-2008 12-05-2005 10-11-2008 13-09-2006 01-01-2009 03-12-2008 22-11-2007 16-10-2008 21-12-2006