

(19) World Intellectual Property Organization
International Bureau



(43) International Publication Date
6 November 2003 (06.11.2003)

PCT

(10) International Publication Number
WO 03/091067 A2

(51) International Patent Classification⁷: **B60R**

(21) International Application Number: PCT/US03/13021

(22) International Filing Date: 25 April 2003 (25.04.2003)

(25) Filing Language: English

(26) Publication Language: English

(30) Priority Data:
60/375,896 26 April 2002 (26.04.2002) US

(71) Applicant and

(72) Inventor: **WILSON, Larry, J.** [US/US]; 2516 Marion
Acres, Commerce Township, MI 48382 (US).

(74) Agent: **DANA, Andrew, Alden;** MacLean-Foog Com-
pany, 1000Allanson Road, Mundelein, IL 60060 (US).

(81) Designated States (*national*): AE, AG, AL, AM, AT, AU,
AZ, BA, BB, BG, BR, BY, BZ, CA, CH, CN, CO, CR, CU,

CZ, DE, DK, DM, DZ, EC, EE, ES, FI, GB, GD, GE, GH,
GM, HR, HU, ID, IL, IN, IS, JP, KE, KG, KP, KR, KZ, LC,
LK, LR, LS, LT, LU, LV, MA, MD, MG, MK, MN, MW,
MX, MZ, NO, NZ, OM, PH, PL, PT, RO, RU, SC, SD, SE,
SG, SK, SL, TJ, TM, TN, TR, TT, TZ, UA, UG, US, UZ,
VC, VN, YU, ZA.

(84) Designated States (*regional*): ARIPO patent (GH, GM,
KE, LS, MW, MZ, SD, SL, SZ, TZ, UG, ZM, ZW),
Eurasian patent (AM, AZ, BY, KG, KZ, MD, RU, TJ, TM),
European patent (AT, BE, BG, CH, CY, CZ, DE, DK, EE,
ES, FI, FR, GB, GR, HU, IE, IT, LU, MC, NL, PT, RO,
SE, SI, SK, TR), OAPI patent (BF, BJ, CF, CG, CI, CM,
GA, GN, GQ, GW, ML, MR, NE, SN, TD, TG).

Published:

— without international search report and to be republished
upon receipt of that report

For two-letter codes and other abbreviations, refer to the "Guidance Notes on Codes and Abbreviations" appearing at the beginning of each regular issue of the PCT Gazette.

(54) Title: THEFT DETERRENT WHEEL FASTENER CAP ASSEMBLY AND METHOD

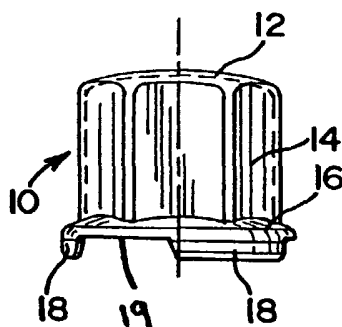

(57) Abstract: The present invention relates to a decorative cap for enclosing the head of a wheel bolt or wheel nut or the like which fastens a wheel to the hub of a vehicle, comprising: an end closure wall, an endless side wall extending from an outer periphery of said end closure wall, a skirt extending radially outwardly from a periphery of said side wall, and said skirt having a plurality of locking lips depending therefrom for releasably gripping the head.

WO 03/091067 A2

THEFT DETERRENT WHEEL FASTENER CAP ASSEMBLY AND METHOD

This application claims priority from US provisional application serial number
5 60/375,896, filed April 26, 2002, entitled "THEFT DETERRENT WHEEL CAP
ASSEMBLY AND METHOD."

RELATED APPLICATIONS

This invention relates generally to wheel bolts or nuts for fastening a wheel to a
10 vehicle hub. It relates particularly to a decorative cap for a theft deterrent bolt head or
nut.

BACKGROUND OF THE INVENTION

Theft deterrence for automobile or truck wheels, for example, is sometimes
15 provided with a key type removal mechanism. One of the plurality of wheel bolts or
nuts has a unique keying feature incorporated, and the bolt or nut can only be removed
with a key carried by the vehicle operator.

Although anti-theft lock mechanisms such as these are effective against amateur
thieves, professionals defeat them given a reasonable amount of time to do so. The
20 present invention is designed to further thwart thieves seeking to remove vehicle wheels
quickly.

There are numerous decorative caps for wheel nuts or bolts in the prior art.
Some examples are seen in the Toth U.S. Patent No. 4,775,272, the Lanham U.S. Patent
No. 4,968,202 and the Nolan et al. U.S. Patent No. 5,180,266, for example. None
25 provide the advantages hereinafter discussed in relation to the present invention.

BRIEF SUMMARY OF THE INVENTION

It is an object of the invention to provide an improved decorative wheel cap for a
vehicle wheel bolt or wheel nut.

30 It is another object to provide a new and improved wheel bolt or wheel nut and
decorative cap assembly which functions as a theft deterrent.

Still another object is to provide a method of concealing a keyed wheel bolt or
wheel nut head with an improved decorative cap, as well as removing the cap when
access to the bolt or nut is desired.

The foregoing and other objects are realized in a decorative cap for a wheel bolt or nut head, a decorative cap and wheel bolt or nut assembly, and a tool and method for removing the cap from a bolt or nut head. The cap, assembly, tool and method embodying features of the invention are illustrated and described below.

5

BRIEF DESCRIPTION OF SEVERAL VIEWS OF THE DRAWINGS

The invention, including the construction of wheel fastener caps, their assembly with wheel bolts and wheel nuts, and the method of use are illustrated more or less diagrammatically in the drawings, in which:

- 10 FIGURE 1 is a side elevational view of a decorative wheel cap embodying features of the invention;
- FIGURE 2 is a top plan view of the wheel cap seen in FIGURE 1;
- FIGURE 3 is a bottom plan view of the wheel cap seen in FIGURES 1 and 2;
- FIGURE 4 is a side elevational view (partially in section) of a wheel bolt with an
- 15 internal key drive and which is adapted to receive the wheel cap seen in FIGURES 1-3;
- FIGURE 5 is a top plan view of the bolt seen in FIGURE 4;
- FIGURE 6 is a side elevational view of an assembly comprising the cap of FIGURES 1-3 and the bolt of FIGURES 4 and 5;
- FIGURE 7 is an end elevational view of a tool employed according to the
- 20 invention for removing a wheel fastener cap embodying the invention from a wheel bolt or nut;
- FIGURE 8 is a sectional view taken along line 8-8 of FIGURE 7;
- FIGURES 9A, 9B and 9C show the tool seen in FIGURES 7 and 8 being used in
- 25 push-on, engagement and pull-off steps involved in the cap removal method of the invention;
- FIGURE 10 is a side elevational view (partially in section) of a wheel nut with an external key drive and which is adapted to receive the wheel cap seen in FIGURES 1-3;
- FIGURE 11 is a top plan view of the nut seen in FIGURE 10; and
- 30 FIGURE 12 is a side elevational view of an assembly comprising the cap of FIGURES 1-3 and the nut of FIGURES 10 and 11.

DETAILED DESCRIPTION OF THE INVENTION

Referring now to the drawings, and particularly to FIGURES 1-3, a decorative cap for a vehicle wheel bolt or nut is seen generally at 10. The cap 10 is preferably formed in one piece from stainless steel sheet metal and includes a dome-shaped outer wall 12 and a generally cylindrical side wall 14 extending therefrom. A radially outwardly extending skirt 16 is formed around the inner end of the side wall 14.

The side wall 14 is polygonal in cross-sectional configuration so that it will appear to fit over the torque wrench gripping section of a wheel bolt head or wheel nut head in a manner hereinafter discussed. The skirt 16 has three identical locking lip segments 18 on its free inner edge 19, and extending slightly inwardly toward the center line CL of the cap 10. Each lip segment 18 extends around approximately 60° of the circumference of the skirt 16. The segments 18 are evenly spaced around the edge 19.

Referring now to FIGURES 4 and 5, a wheel bolt to which the cap 10 is assembled in use is seen generally at 130. The wheel bolt 130 includes an externally threaded shaft section 132 at its inner end, an enlarged annular intermediate section 134 above the threaded shaft section and a head section 136 at its outer end.

The enlarged annular intermediate section 134 has a load bearing surface 138 which is segmentally spherical in shape, but might also be frusto-conical. Extending outwardly from the outer edge of the surface 138 in the intermediate section 134 is a cylindrical surface 142.

The intermediate section 134 is capped with an annular shoulder 144 which is somewhat frusto-conical in shape, albeit inverted relative to the load bearing surface 138. The outer periphery of the shoulder 144 overhangs the cylindrical surface 142 to form an annular, outwardly protruding bead 146.

The head section 136 has a cylindrical outer surface 152. Extending axially inwardly from the free end 154 of the head section 136 is an internal drive well 156. The well 156 has a series of axially extending key grooves 158 formed in its inner surface. The key grooves are designed to mate, in a conventional manner, with a complementary key (not shown) which is used with a conventional wrench to tighten or loosen the bolt 130.

Referring now to FIGURE 6, the cap 10 is assembled with the bolt 130 in the manner illustrated. Assembly is normally by hand, with the cap 10 sliding loosely over the cylindrical surface 152 of the bolt head section 136 until the lip segments 18 are

forced outwardly by the shoulder 144 of the intermediate bolt section and then snap inwardly under the bead 146.

5 With the cap 10 in place, the bolt 130 looks just like every other capped bolt (not shown) holding a wheel in place. The difference is that the other bolts are conventional polygon head bolts, and not internally keyed like the bolt 130. All of the bolts have identical caps, but only one is specially keyed in the manner of bolt 130. A thief is not only faced with one specially keyed bolt as a deterrent, but also the problem of locating that bolt (or even looking for it) in the little time normally available.

10 Referring now to FIGURES 7-9, a cap removal tool embodying features of the invention is seen generally at 210. In FIGURES 7 and 8 the tool 210 is shown alone. In FIGURES 9A, 9B and 9C, it is shown being used in sequential steps to remove a cap 10 from a wheel bolt 130.

15 The tool 210 comprises an elongated cylindrical sleeve 212 fabricated of steel tubing or, in the alternative, a suitable plastic material. The sleeve 212 includes an outer hand grip section 214 in which the tubing wall is relatively thick, as at 216. The sleeve 212 also includes an inner cap gripping section 218 in which the tubing wall is thinner, as at 222.

20 The cap gripping section 218 of the tool 210 has an annular, inwardly extending ledge 224 formed on its free end. The cap gripping section 218 is also segmented along about one-half its length, inwardly of the ledge 224, by axially extending cut-outs 226. The resulting configuration of the section 218 is one of six axially extending fingers 228 which can flex inwardly and outwardly in a manner hereinafter discussed.

25 The tool 210 is used by pushing it onto an installed cap 10 in the manner shown in FIGURE 9A. The ledge segments 224 are forced over locking lip segments 18 of the cap 10. The ledge segments 224 then spring inwardly, behind the free ends of the locking lip segments 18, to the position shown in FIGURE 9B.

The operator then pulls the tool 210 away from the bolt 130, as seen in FIGURE 9C. The ledge segments 224 on the tool 210 pull the lip segments 18 of the cap 10 back over the head 146 on the bolt 130, releasing the cap and permitting its removal by hand.

30 To this point, the inventions disclosed have been described in the context of a vehicle wheel bolt 130 which is internally keyed, as at 158. As was previously pointed out, however, the inventions are equally applicable to vehicle wheel nuts and, particularly, keyed wheel nuts.

FIGURES 10 and 11 illustrate a keyed wheel nut 330 embodying features of the invention. The wheel nut 330 is similar to the lug bolt 130 previously discussed with respect to its invention-related features.

5 The nut 330 includes an internally threaded bore 332, an enlarged annular intermediate body section 334 around the threaded bore and a head section 336 adjacent that. The annular intermediate section 334 has a generally frusto-conical load-bearing surface 338 (which might also be spherical). Extending upwardly from the outer edge of the surface 338 in the intermediate section 334 is a cylindrical surface 342.

10 The intermediate section 334 is capped with an annular shoulder 344 which is somewhat frusto-conical in shape, albeit inverted relative to the load-bearing surface 338. The outer periphery of the shoulder 344 overhangs the cylindrical surface 342 to form an annular, outwardly protruding bead 346.

15 The head section 336 has a generally cylindrical outer surface 352. The surface 352 has a series of axially extending key grooves 358 formed in it. The key grooves are designed to mate, in a conventional manner, with a complementary key (not shown) which is used with a torque wrench to tighten or loosen the bolt 330.

A cap 10 is mounted on the wheel nut 330 in the manner shown in FIGURE 12. This is accomplished in a manner identical to that previously described in relation to the bolt 130. Correspondingly, the cap 10 removal process is identical.

CLAIMS

1. A decorative cap for enclosing the head of a wheel bolt or wheel nut or the like which fastens a wheel to the hub of a vehicle, comprising:
- 5
- a) an end closure wall;
 - b) an endless side wall extending from an outer periphery of said end closure wall,
 - c) a skid extending radially outwardly from a periphery of said side wall, and
 - 10 d) said skirt having a plurality of locking lips depending therefrom for releasably gripping the head.
2. The decorative cap of Claim 1 further characterized in that:
- 15
- a) said end closure wall, said side wall and said skirt, including said locking lips, are unitary and comprise a sheet material which is flexible and resilient.
3. The decorative cap of Claim 2 further characterized in that:
- 20
- a) said sheet material is stainless steel.
4. The decorative cap of Claims 1, 2 or 3 further characterized in that:
- a) said plurality of lips comprise at least three lips, substantially evenly spaced around said skirt.
- 25
5. The decorative cap of Claims 1, 2 or 3 further characterized in that:
- a) each of said lips extends axially of said side wall as well as slightly radially inwardly therefrom.
- 30
6. An assembly of a decorative wheel cap and the head of a wheel bolt or wheel nut, comprising:
- a) a bolt or nut head, said head having
 - i) an outer end and an inner end,
 - ii) an annular bead extending radially outwardly from said inner end,

- 5
- 10
- 15
- 20
- 25
- b) a cap including
 - i) an end closure wall,
 - ii) an endless side wall depending from a periphery of said side wall,
 - iii) a skirt extending radially from a free end of said side wall,
 - iv) said skirt having a plurality of locking lips depending therefrom, and
 - c) said cap being releasably seated on said head by said locking lips overlying and gripping said bead.
7. A method of concealing and then disclosing the form of a wheel bolt head or wheel nut head securing a wheel to a vehicle nut by releasably securing a cap over said head and then releasing it, comprising the steps of:
- a) providing a head with an annular bead extending around it;
 - b) providing a decorative cap including a wall for enclosing said head and a skirt extending radially out from said wall, said skirt having retaining lips thereon;
 - c) seating said cap on said head by manually forcing said lips over said bead so that they bend outwardly and shape resiliently behind said bead;
 - d) providing a removal tool in the form of a sleeve having radially expandable gripping fingers at one end; and
 - e) placing said sleeve over said cap so as to engage said gripping fingers with said lips and withdrawing said sleeve to disengage said lips from said bead.

FIG.1

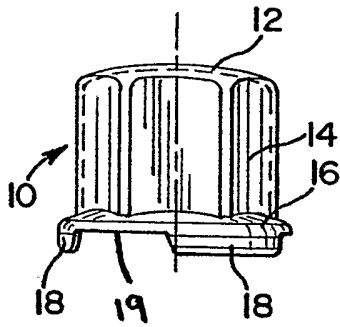

FIG.2

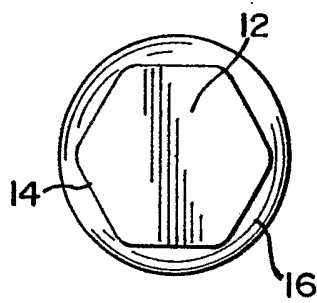

FIG.3

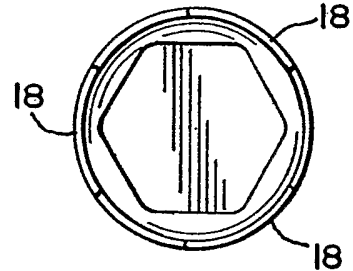

FIG.4

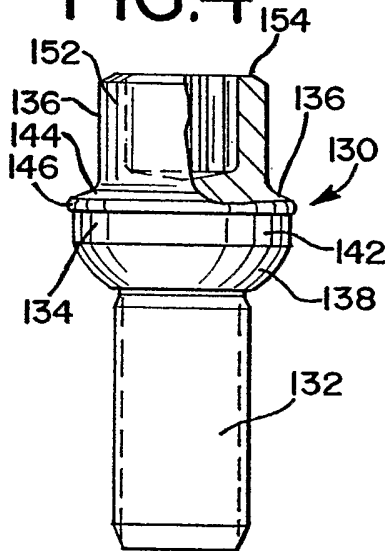

FIG.5

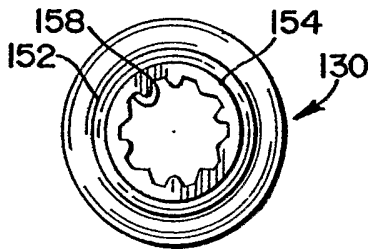

FIG.6

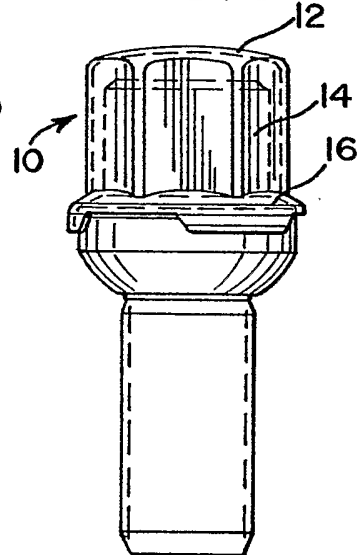

FIG.7

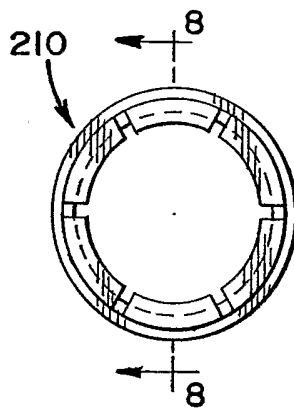
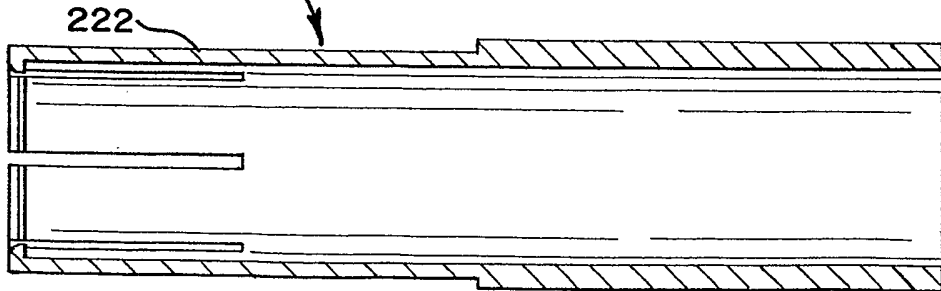

FIG.8



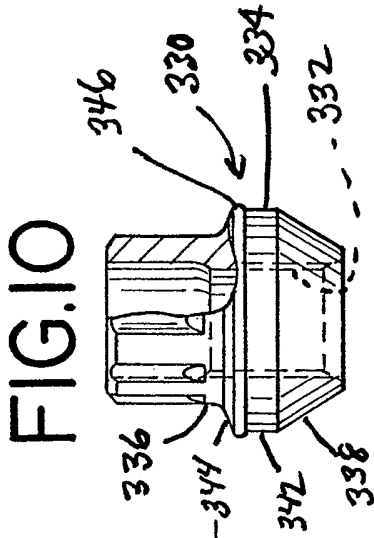

FIG. 10

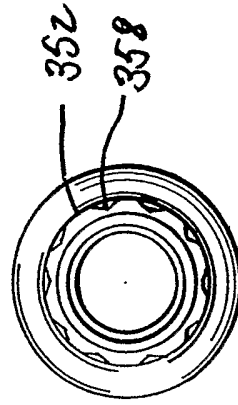

FIG. 11

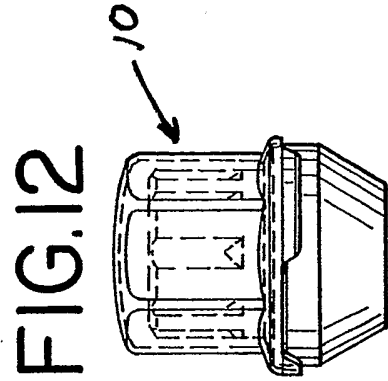

FIG. 12

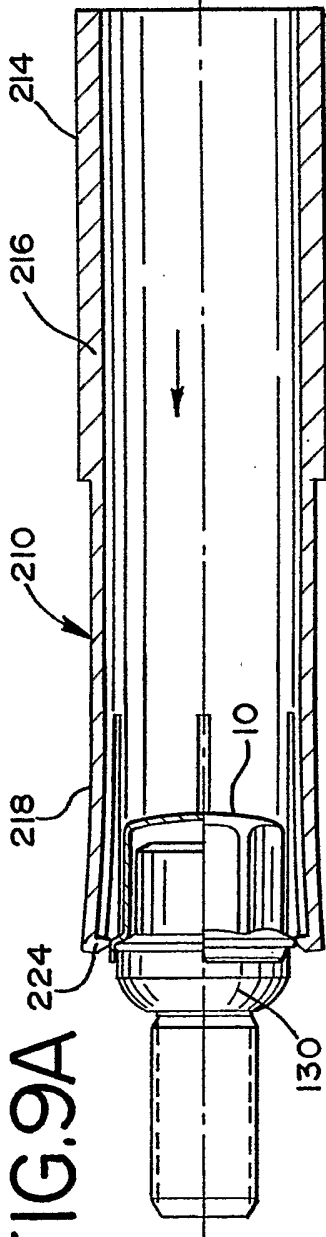

FIG. 9A

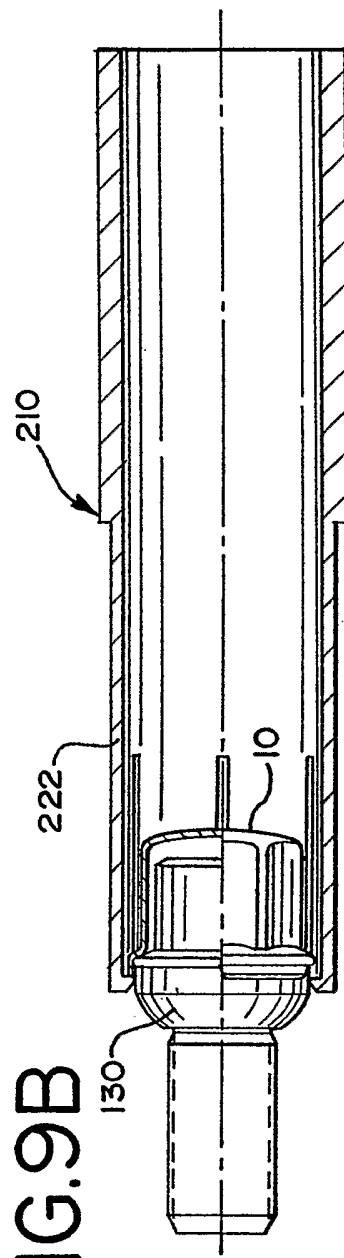

FIG. 9B

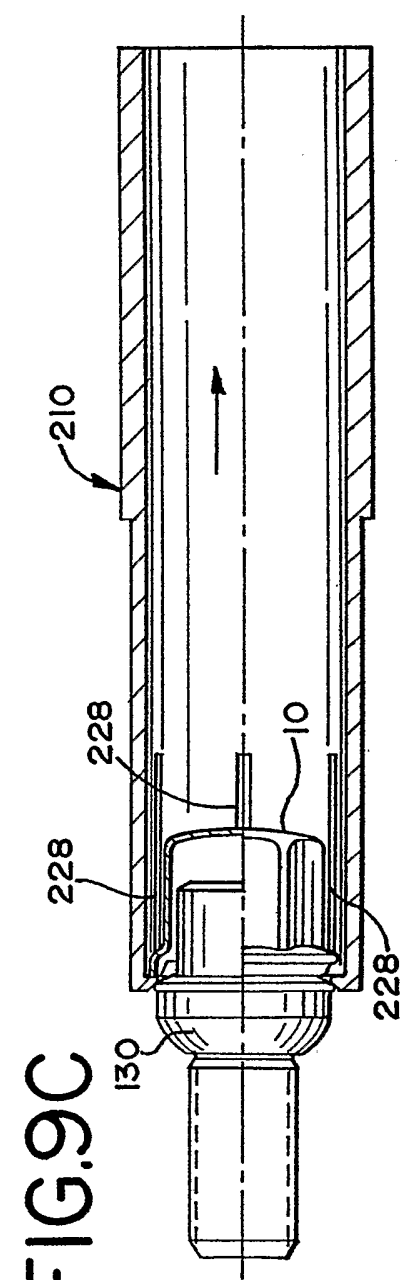

FIG. 9C