

(No Model.)

L. C. DEMAIN.  
CONCEALED BATTERY.

No. 525,537.

Patented Sept. 4, 1894.

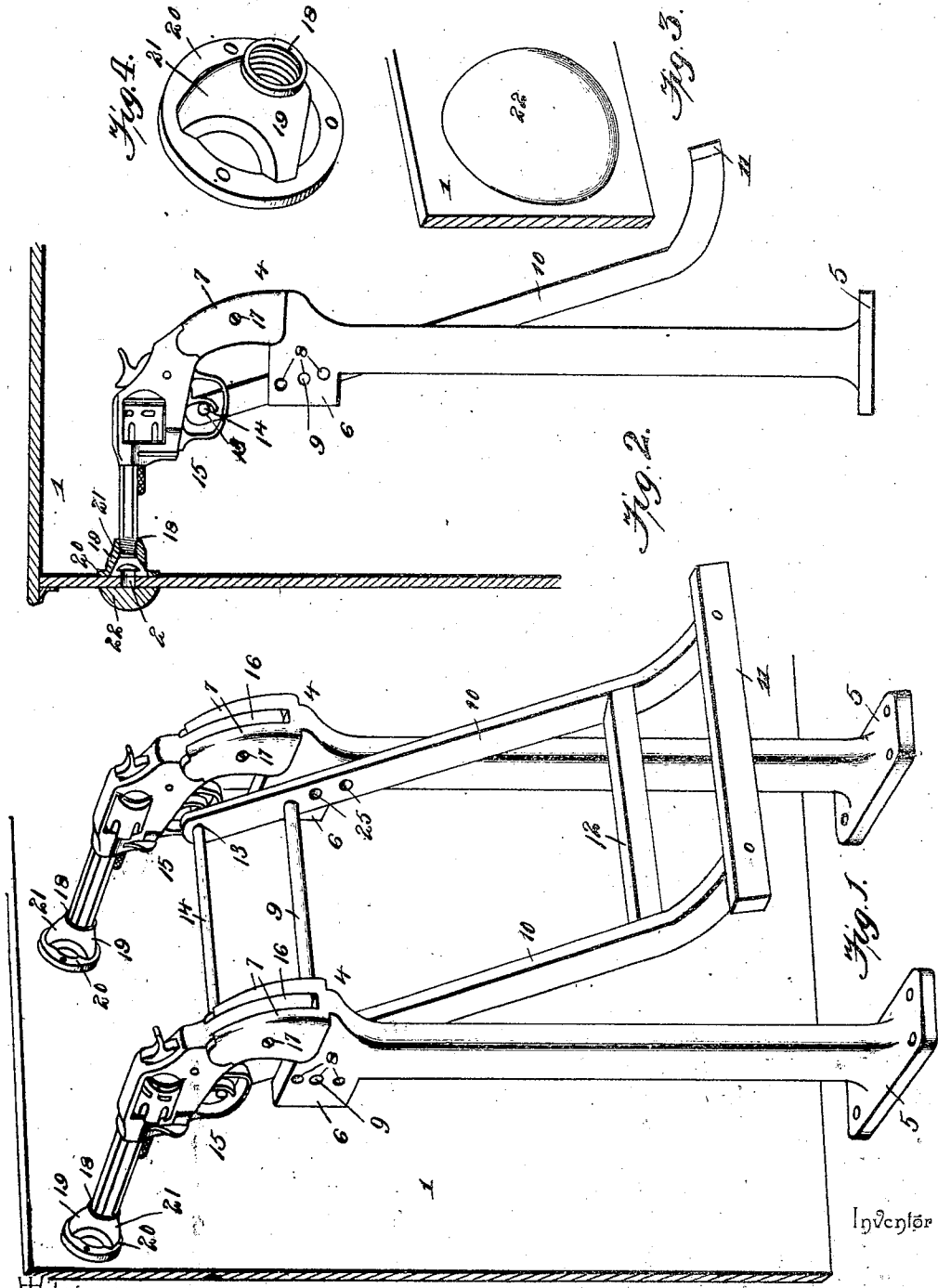

Witnesses,

*John C. Shaw.*  
*J. Brown*

By *his* Attorneys, *Louis C. Demain,*

*C. Snow & Co.*

Inventor

# UNITED STATES PATENT OFFICE.

LOUIS C. DEMAIN, OF FAIRFAX, VERMONT.

## CONCEALED BATTERY.

SPECIFICATION forming part of Letters Patent No. 525,537, dated September 4, 1894.

Application filed April 12, 1894. Serial No. 507,275. (No model.)

*To all whom it may concern:*

Be it known that I, LOUIS C. DEMAIN, a citizen of the United States, residing at Fairfax, in the county of Franklin and State of Vermont, have invented a new and useful Pistol-Firing Device, of which the following is a specification.

The object of this invention is to provide a device which will afford protection to bankers and other merchants from the assaults of cranks and robbers; and this end I attain by arranging a series of revolvers behind the counter or a screen in the office, so that they may be fired, upon the entry of the undesirable persons.

In the accompanying drawings: Figure 1 represents a perspective view of a rear side of a counter having my appliance in connection therewith; Fig. 2, a side elevation of the device, showing the counter in cross-section; Fig. 3, a detail perspective view of the device for concealing the muzzles of the revolvers; Fig. 4, a similar view of the arrangement for securing the muzzles to the counter.

The numeral 1 indicates the counter, which may, of course, be of any preferred construction, and which I provide with the openings 2, to which the muzzles of the revolvers pass.

15 indicates the revolvers, which are here shown to be two in number and supported each by the standards 4. These devices are one for each revolver, and are provided with the enlarged bases 5, formed with screw-openings therein through which screws pass to secure the standards to the floor.

The standards 4 are each formed at their upper ends with the forwardly-extending portions 6, and with the parallel and approximately vertical studs 7. The former of these devices, projections 6, are provided with the vertical series of holes 8, through which the pin 9 of the trigger-operating mechanism passes.

The trigger-operating mechanism consists of two parallel bars 10, curved rearwardly at their lower ends, and provided thereat with the cross-bar or foot-piece 11, which is extended beyond the standards 4. The bars 10 are also provided with a second brace-rod 12, extending from one to another and rigidly secured to each.

Pin 9 extends from one of the bars 10 to an-

other, and beyond the same, and has its ends projected beyond the bars and journaled in one of the openings 8 in the standards 4, whereby the operating frame is mounted on the standards so as to be capable of an oscillatory movement thereon. The pin 9 is adapted to fit in one of the series of openings 25, in the bars 10, which openings are one for each of the openings 8, and in transverse alignment therewith.

Formed in the extreme upper ends of the rods or bars 10 are the openings 13, in which the trigger firing pin 14 is arranged. This pin extends parallel with the pin 9, and has its ends extended beyond the bars 10, as in the pin 9. The pin 14 is arranged so that it will lie about level with the top of the arms or studs 7, and in position to engage the triggers of the revolvers 15. Each of the studs 7 have their adjacent faces formed plane and parallel with each other, so that they may receive the handle-portions 16 of the revolvers, and the usual side-plates of the revolver handles are to be removed before the revolvers can be secured in place. This is shown in the drawings.

17 indicates two set-screws, one for each revolver, which pass through one of the studs 7, and are adapted to bind against the revolver-handles, thus securing them in place. The ends of the studs 7 are formed so that they will fit snugly in the space usually occupied by the side-plates of the handles.

When the revolvers 15 are arranged in place their triggers will project over the portions 6 of the respective standards 4, and so that the pin 14 will be in position to engage them, while the muzzles project forwardly to the opening 2 of the counter 1. Here the muzzle is screwed into the opening 18 of the bracket 19. The bracket 19 consists of a metallic casting having a rim 20 rigidly secured to the rear side of the counter, and having the arms 21 projecting rearwardly therefrom and forming the opening 18, at their juncture. Thus the muzzles of the revolvers are rigidly connected to the counter. By means of these devices 19 the revolvers are secured with greater rigidity and the standards 4 assisted in their function.

Secured over the openings 2, on the outer sides of the counter, are the buttons 22, which

are formed of wood, and which are adapted to have the appearance of the usual ornaments with which counters are provided. The purpose of these devices is to hide the openings 2, so as to prevent the rough appearance which they would otherwise give, they being secured in place by glue or small tacks only, so that they may be readily removed by the ball of the revolver as it is fired.

10 In operation, when a person behind the counter is approached by a robber or other dangerous character, all that will be necessary for him to do is to move the trigger-operating frame forward on its pin 9, thus bringing pin 14 into engagement with the triggers of the revolvers and causing them to be fired. This will force the buttons 22 from their places and allow the bullets of the revolvers to pass the counter and into the room, thus alarming, if not wounding, the objectionable persons. The revolvers will be of the "self-cocking" class so that the trigger-mechanism may be moved a plurality of times and cause the firing of the revolvers each time.

25 By means of the series of holes 8 and 25 the bars 10 may be pivoted at any part within the extent of the holes and pin, thus compensating for the difference in the heights of the standards 4, such changes being made necessary by the varying heights of counters. Thus, if the standards had to be made longer than they are shown, it would be necessary to make bars 10 correspondingly long, and this would, in turn, make it necessary to pivot them near the lower ends, which can be attained by changing the position of pin 9, and placing them in the holes 8, which are adjacent to the holes 25, occupied by the pin 9.

40 Having described my invention, what I claim is—

1. A pistol-firing device comprising a rigid and vertical standard adapted to have the pistol secured thereto, and a lever fulcrumed to the standard and adapted to engage the trigger of the pistol, whereby the pistol may be fired, substantially as described.

2. A pistol-firing device consisting of a rigid standard having two parallel lugs arising

therefrom and adapted to have the pistol secured therebetween, the standard having a vertical series of pivot-holes therein, and a lever provided with a pin adapted to fit in one of the holes whereby the lever is pivoted, and a stud secured to the lever and adapted to engage the trigger of the pistol whereby the pistol may be fired by oscillating the lever, substantially as described.

3. A pistol-firing device consisting of two or more standards rigidly secured to a stationary object, and adapted to have a pistol secured to each, and a trigger-frame pivoted to and arranged between the standards and having two studs thereon, adapted to engage the pistol triggers, whereby the pistols may be fired by oscillating the levers, substantially as described.

4. A pistol-firing device consisting of two or more standards adapted to be rigidly secured to a stationary object and each having two parallel standards thereon between which the pistols are adapted to be secured, and a trigger frame arranged between the standards and having a pin thereon, said pin being adapted to fit into openings in the standards and to be pivoted thereby, and studs on the frame and adapted to engage the pistol triggers, whereby the pistols may be fired by oscillating the frame, substantially as described.

5. A pistol-firing device consisting of two or more standards adapted to be rigidly secured to a stationary object and adjacent to an office counter, and to have a pistol secured to each, the pistols being arranged with their muzzles secured in openings in the counter, and a trigger frame pivoted between the standards and having a connection with the pistol triggers, whereby the pistols may be fired by oscillating the frame, substantially as described.

In testimony that I claim the foregoing as my own I have hereto affixed my signature in the presence of two witnesses.

LOUIS C. DEMAIN.

Witnesses:

GEO. E. WATSON,  
GEO. W. PLANCK.