



US008257322B2

(12) **United States Patent**
Koehler et al.

(10) **Patent No.:** **US 8,257,322 B2**
(45) **Date of Patent:** **Sep. 4, 2012**

(54) **TIP PROTECTOR FOR A SAFETY CATHETER**

(75) Inventors: **Thomas T. Koehler**, Simsbury, CT (US);
Kathryn L. Felicito, Rocky Hill, CT (US);
Harsh Chheda, Cheshire, CT (US);
Oscar R. Abriles, Madison, CT (US)

6,749,588 B1 * 6/2004 Howell et al. 604/164.08
7,125,397 B2 10/2006 Woehr et al.
7,214,211 B2 5/2007 Woehr et al.
7,658,725 B2 2/2010 Bialecki et al.
7,785,296 B2 8/2010 Muskatello et al.
7,828,774 B2 * 11/2010 Harding et al. 604/164.08
2004/0225260 A1 11/2004 Villa et al.
(Continued)

(73) Assignee: **Smiths Medical ASD, Inc.**, Rockland, MA (US)

FOREIGN PATENT DOCUMENTS
WO 04/000408 A1 12/2003
(Continued)

(*) Notice: Subject to any disclaimer, the term of this patent is extended or adjusted under 35 U.S.C. 154(b) by 252 days.

OTHER PUBLICATIONS

International Search Report and Written Opinion from counterpart PCT Application No. PCT/US2011/028770 mailed on May 19, 2011 (8 pages).

(21) Appl. No.: **12/792,290**

Primary Examiner — Christopher D Koharski
(74) *Attorney, Agent, or Firm* — Wood, Herron & Evans, LLP

(22) Filed: **Jun. 2, 2010**

(65) **Prior Publication Data**

US 2011/0301551 A1 Dec. 8, 2011

(57) **ABSTRACT**

(51) **Int. Cl.**
A61M 25/00 (2006.01)

(52) **U.S. Cl.** **604/263**

(58) **Field of Classification Search** 604/164.08,
604/110, 111, 192, 198, 263, 272
See application file for complete search history.

A safety catheter includes a catheter hub, a catheter tube, a needle hub, a needle cannula having a tip, and a tip protector. The tip protector includes an outer member having a flexible tab configured to releasably engage with the catheter hub and release therefrom upon inward flexing of the tab. An inner member is positioned entirely within the outer member and has a portion that impedes inward flexing of the tab when disposed adjacent the tab. The inner member is axially shiftable relative to the outer member between a first position wherein the needle tip is distal of the tip protector and the inner member portion is disposed adjacent the tab to impede release from the catheter hub, and a second position wherein the tip is within the outer member and the inner member portion is no longer adjacent the tab and no longer impedes release from the catheter hub.

(56) **References Cited**

U.S. PATENT DOCUMENTS

5,458,658 A 10/1995 Sircom
5,599,310 A 2/1997 Bogert
6,117,108 A 9/2000 Woehr et al.
6,221,047 B1 4/2001 Greene et al.
6,287,278 B1 9/2001 Woehr et al.
6,616,630 B1 9/2003 Woehr et al.
6,689,102 B2 2/2004 Greene
6,709,419 B2 3/2004 Woehr

56 Claims, 21 Drawing Sheets

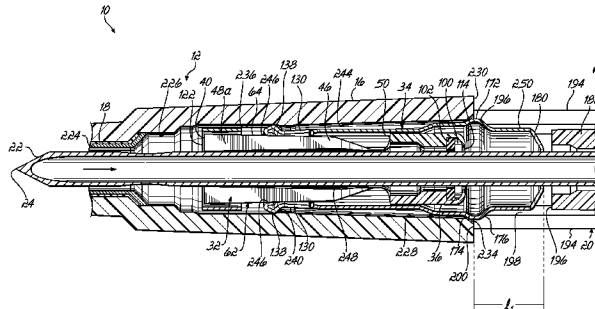
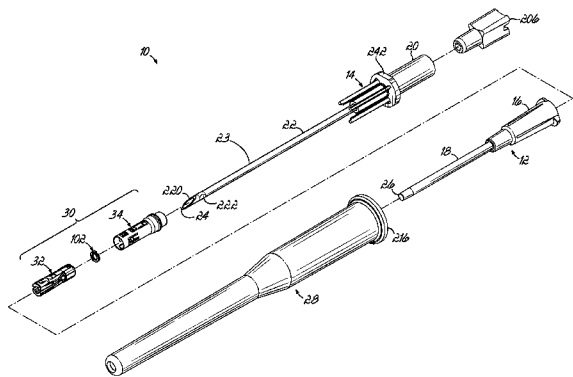

U.S. PATENT DOCUMENTS

2005/0027263 A1 2/2005 Woehr et al.
2005/0113755 A1 5/2005 Greene et al.
2008/0249478 A1 10/2008 Ishikura et al.
2009/0182280 A1* 7/2009 Glowacki et al. 604/164.08
2009/0281499 A1 11/2009 Harding et al.
2010/0016804 A1 1/2010 Muskatello et al.
2010/0168675 A1 7/2010 Cindrich et al.
2010/0222746 A1 9/2010 Burkholz
2010/0222749 A1 9/2010 Baid

2010/0241087 A1* 9/2010 Moulton 604/263
2011/0213307 A1 9/2011 Kawai et al.

FOREIGN PATENT DOCUMENTS

WO 2008/021132 A1 2/2008
WO 2009/010847 A2 1/2009
WO 2010038471 A1 4/2010
WO 2010/127846 A1 11/2010
WO 2011/036574 A1 3/2011

* cited by examiner

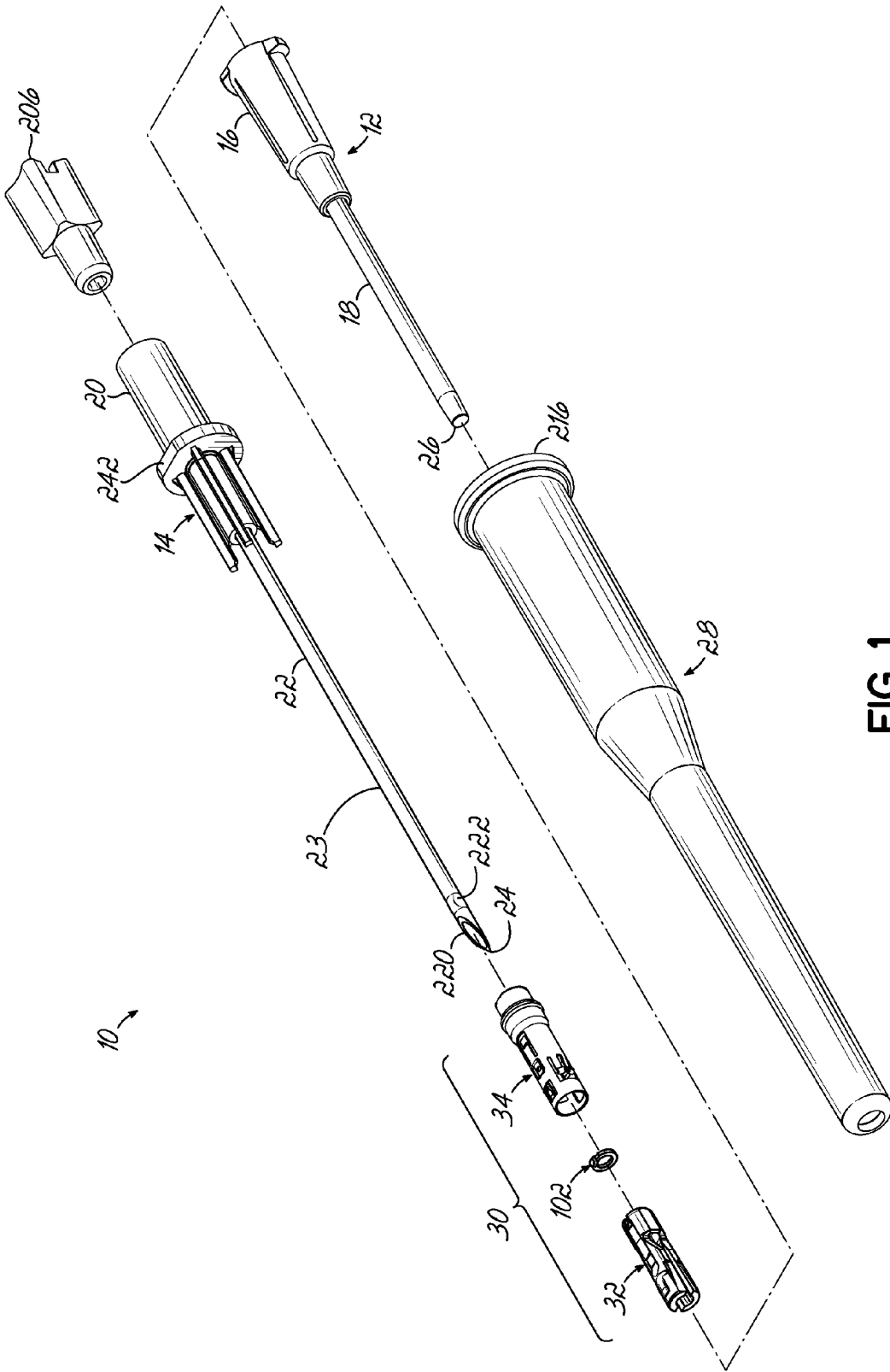

FIG. 1

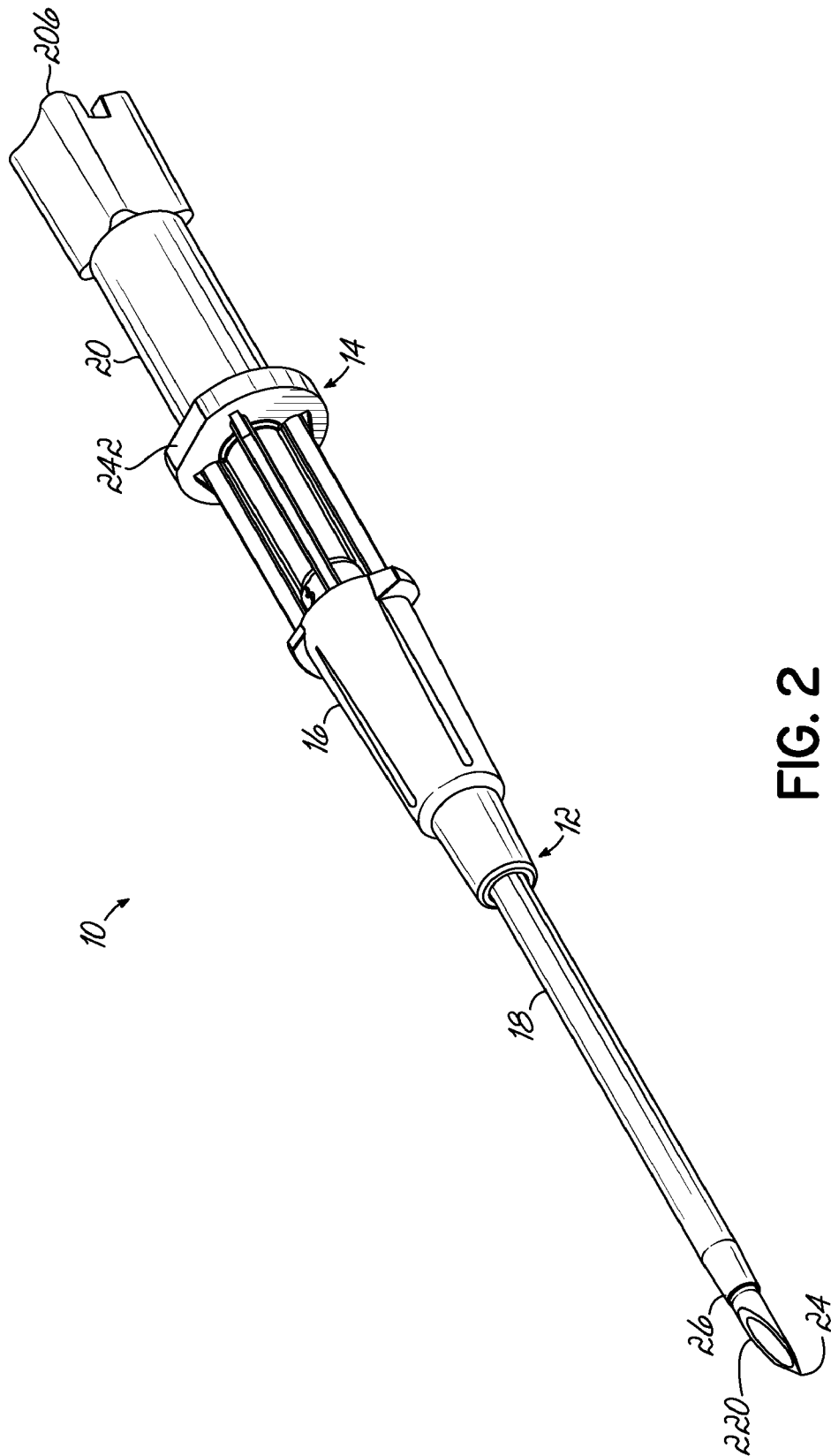

FIG. 2

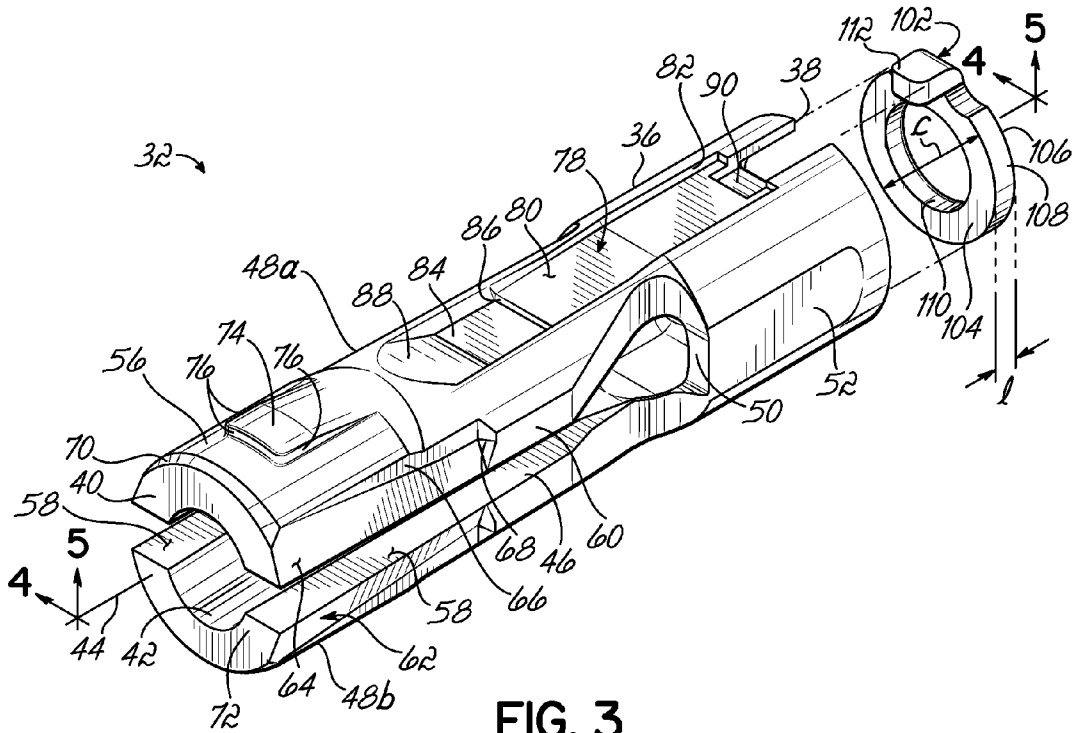

FIG. 3

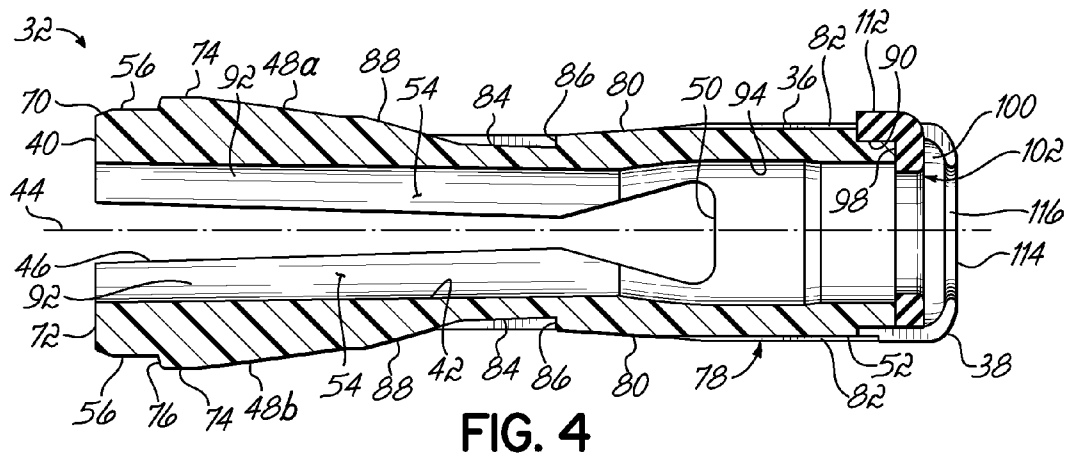

FIG. 4

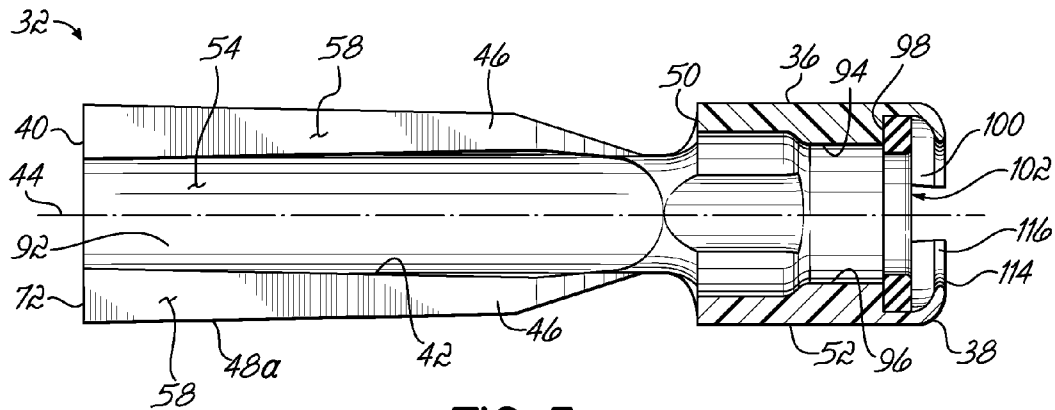

FIG. 5

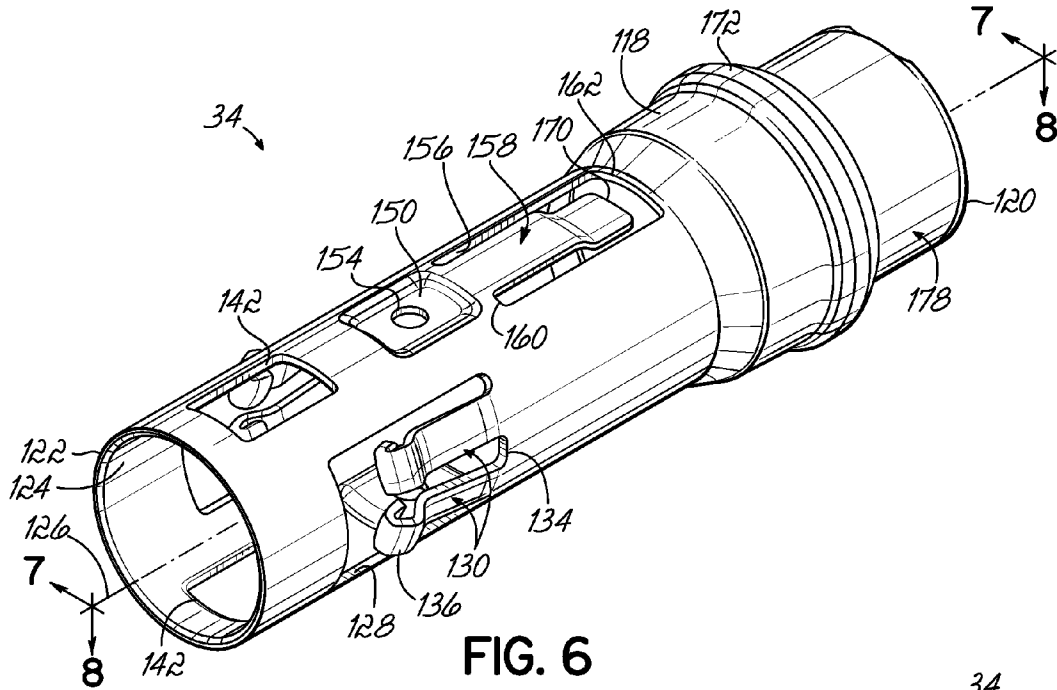

FIG. 6

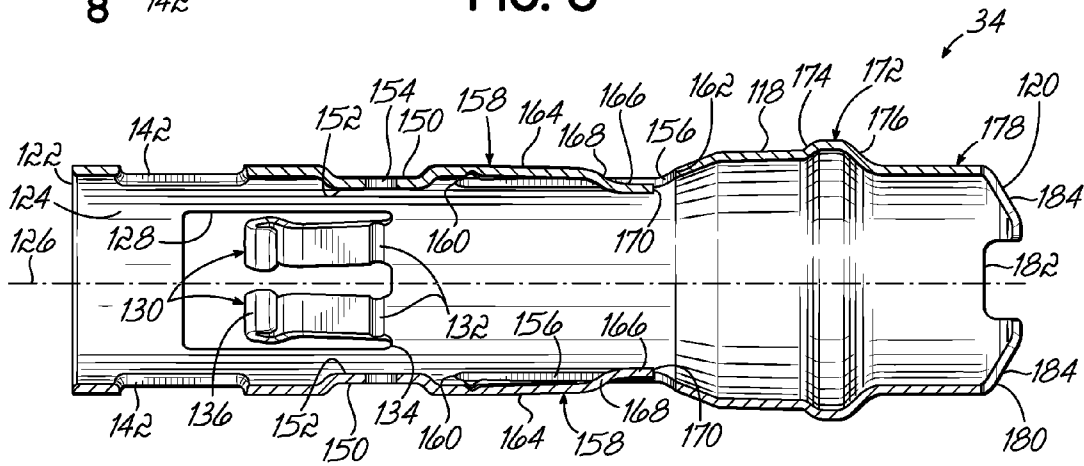

FIG. 7

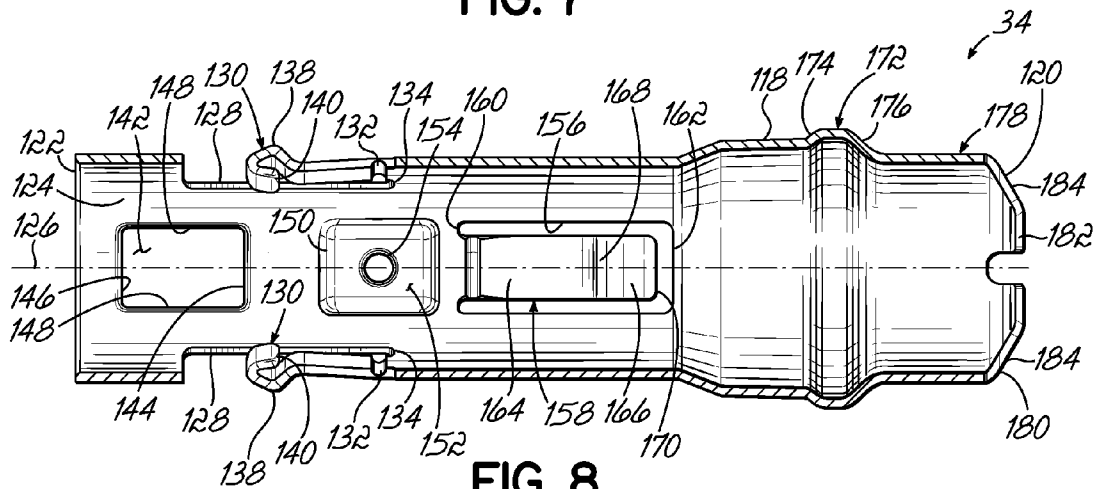
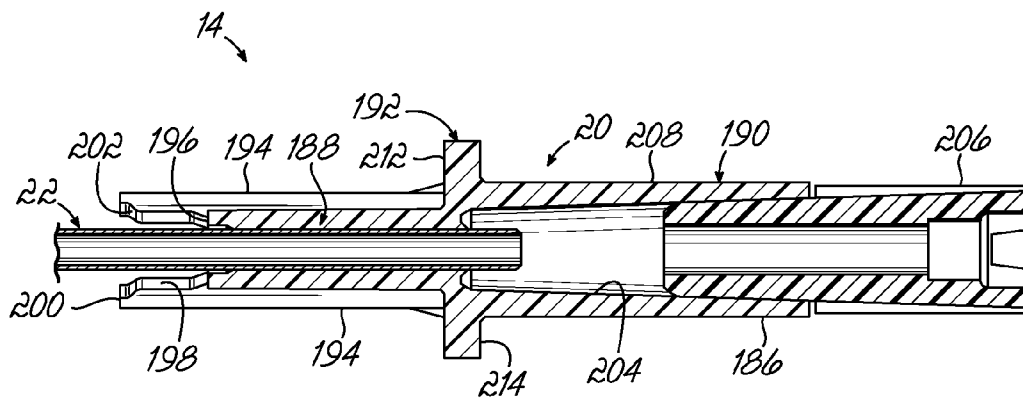
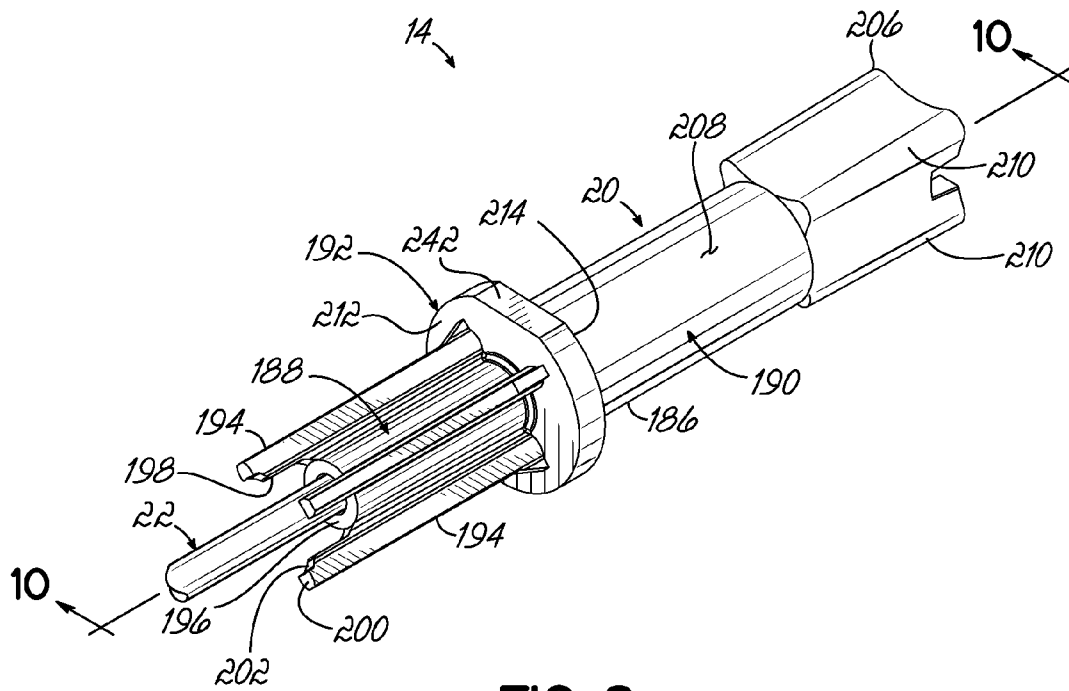

FIG. 8



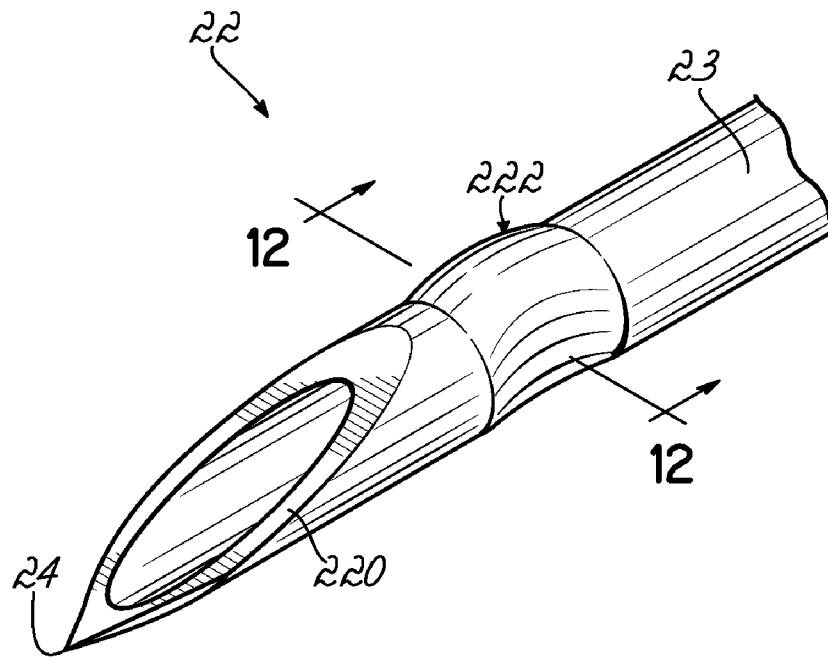

FIG. 11

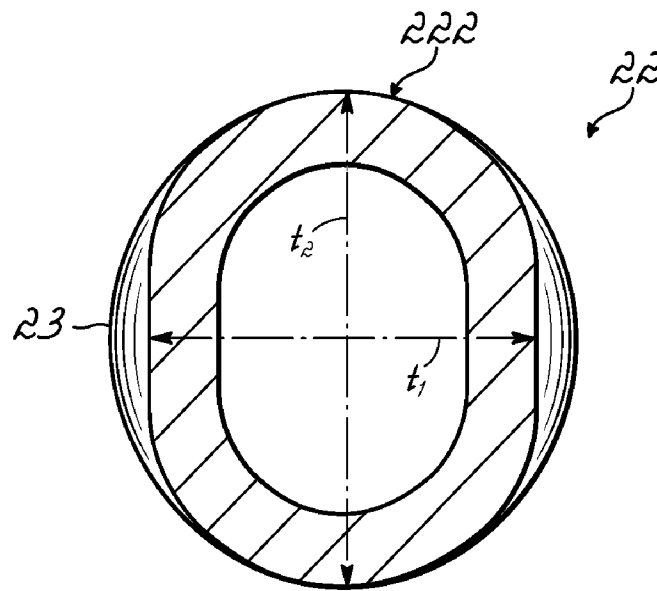

FIG. 12

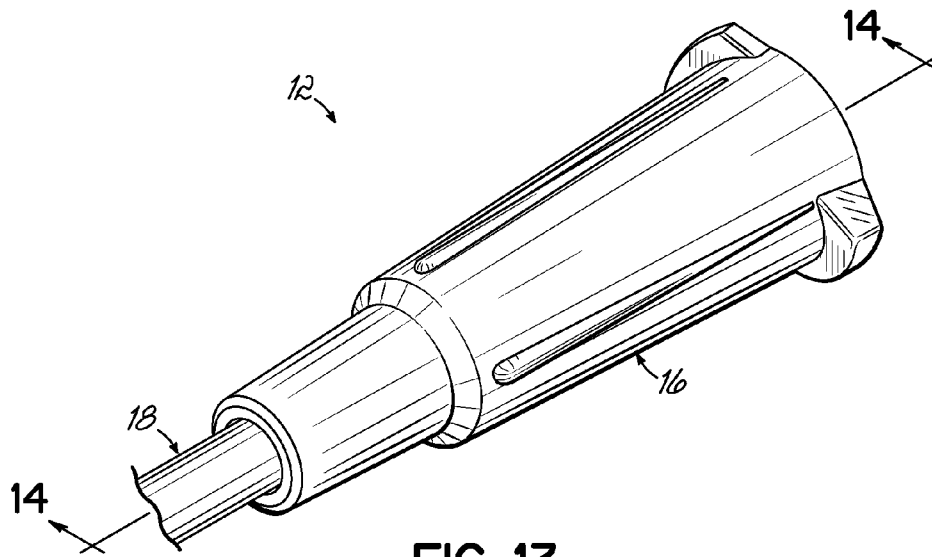

FIG. 13

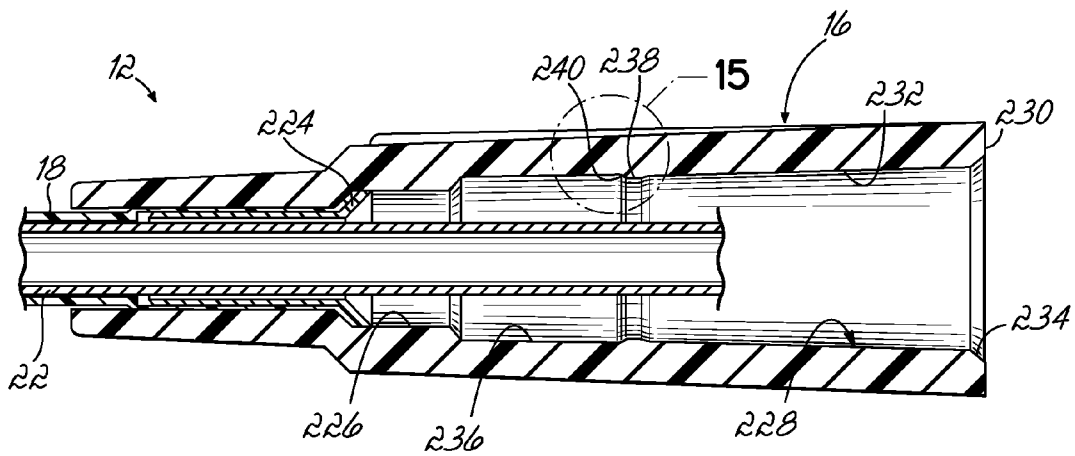

FIG. 14

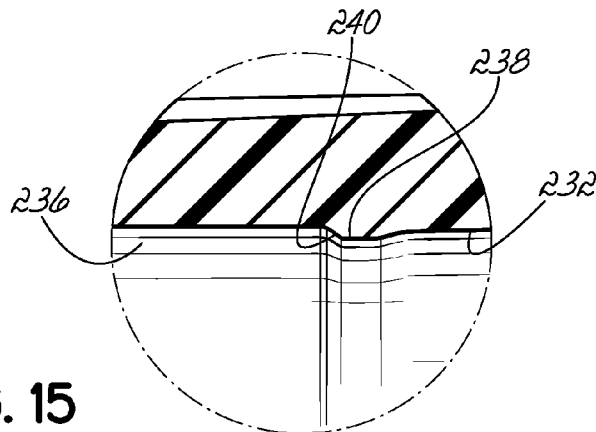
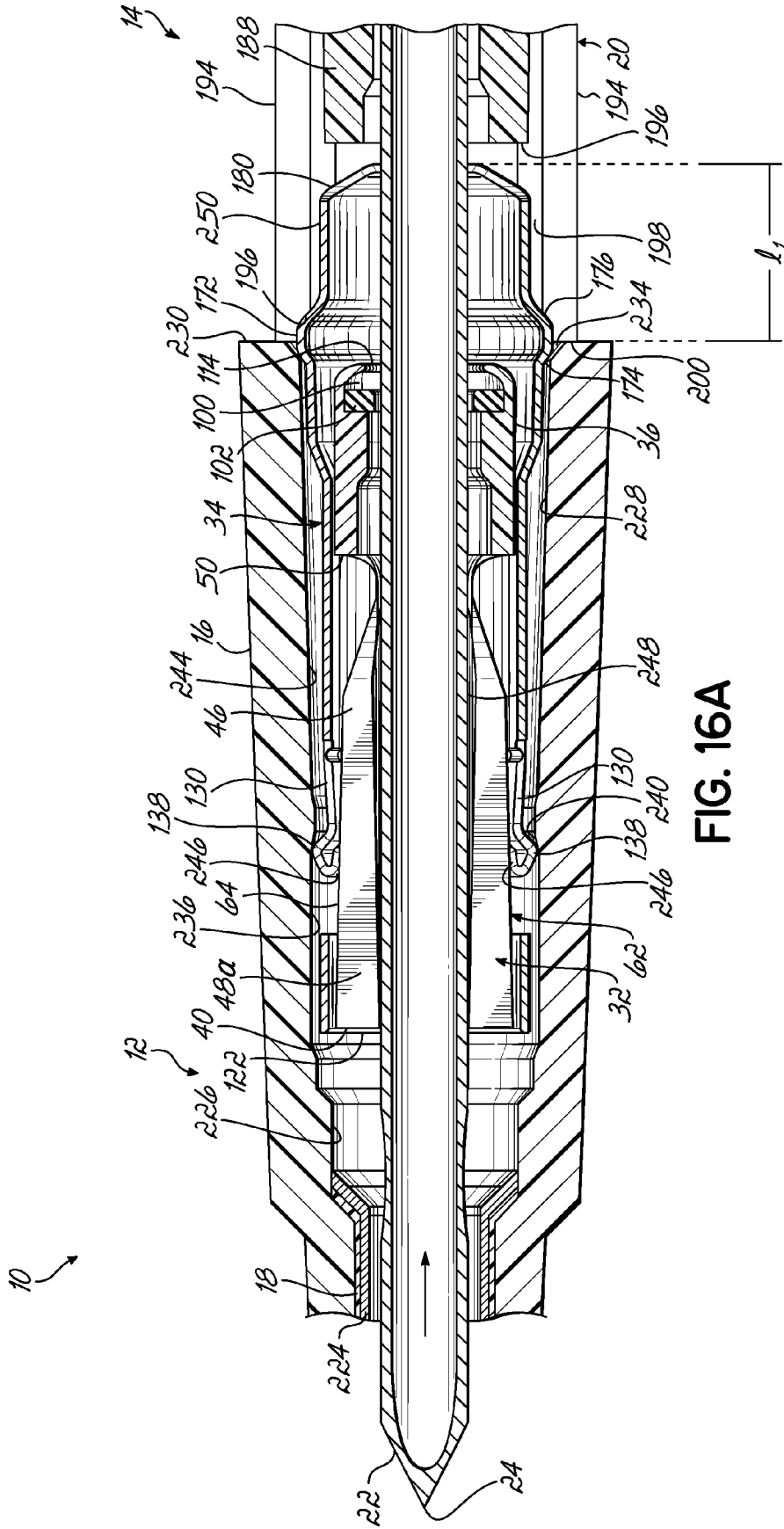
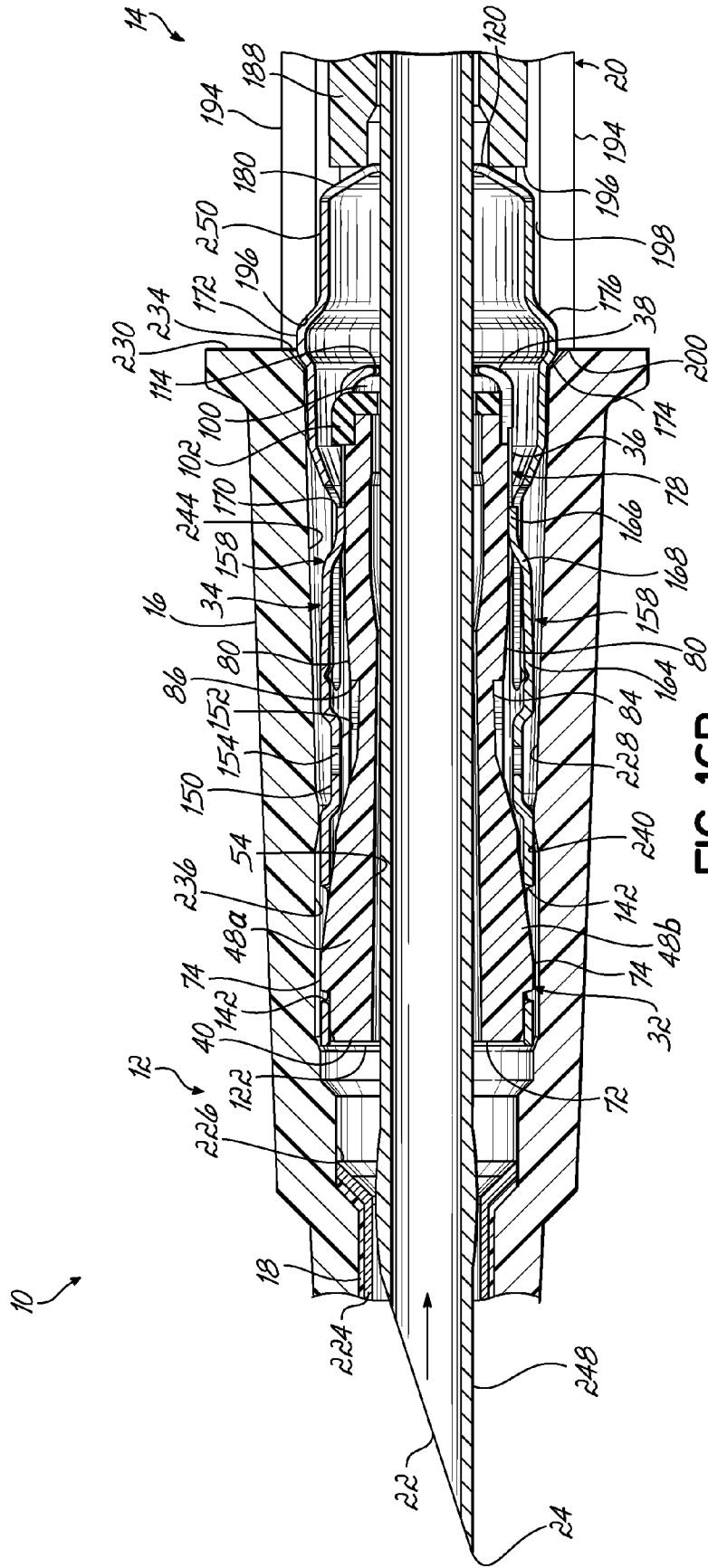
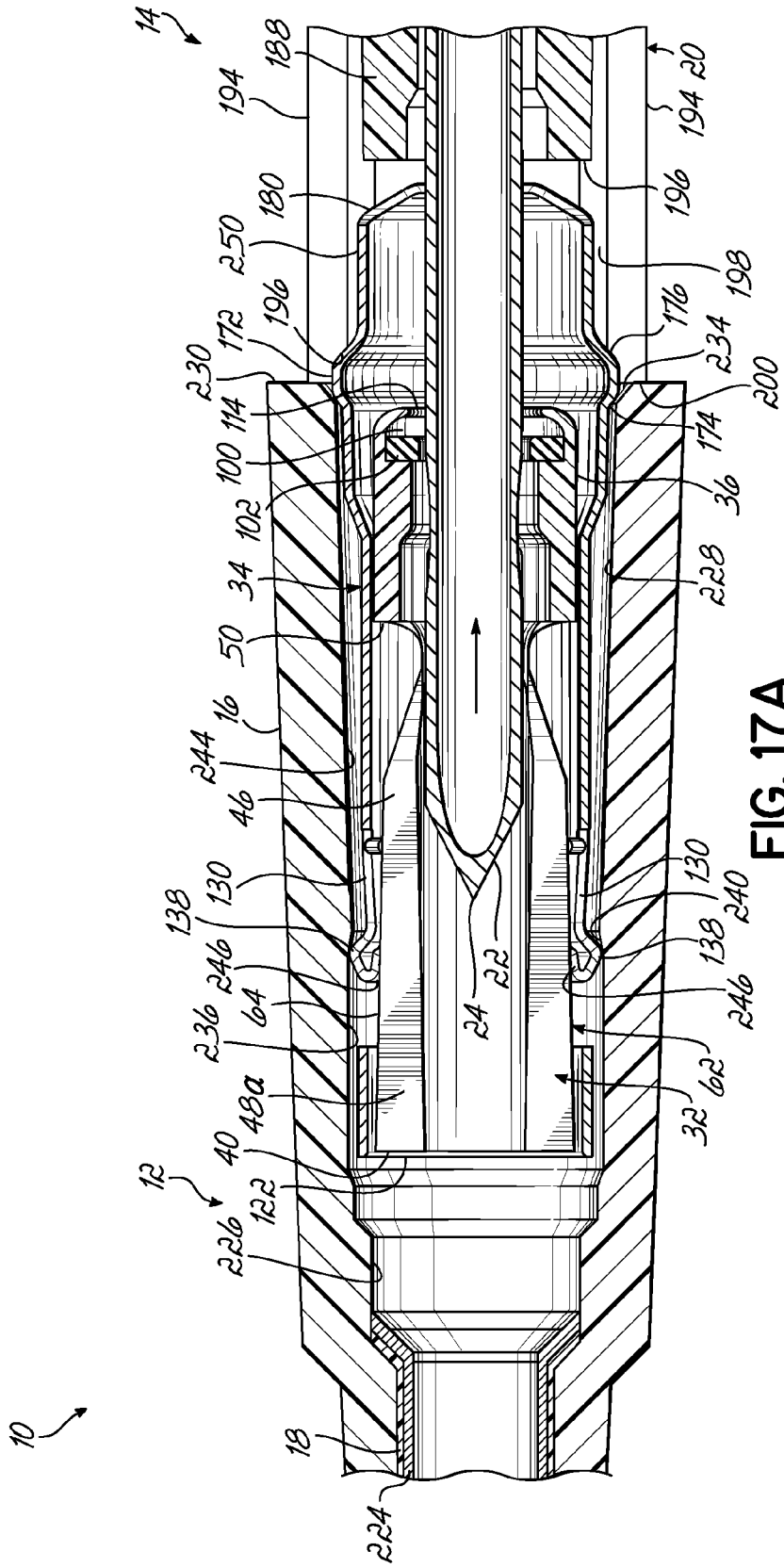

FIG. 15







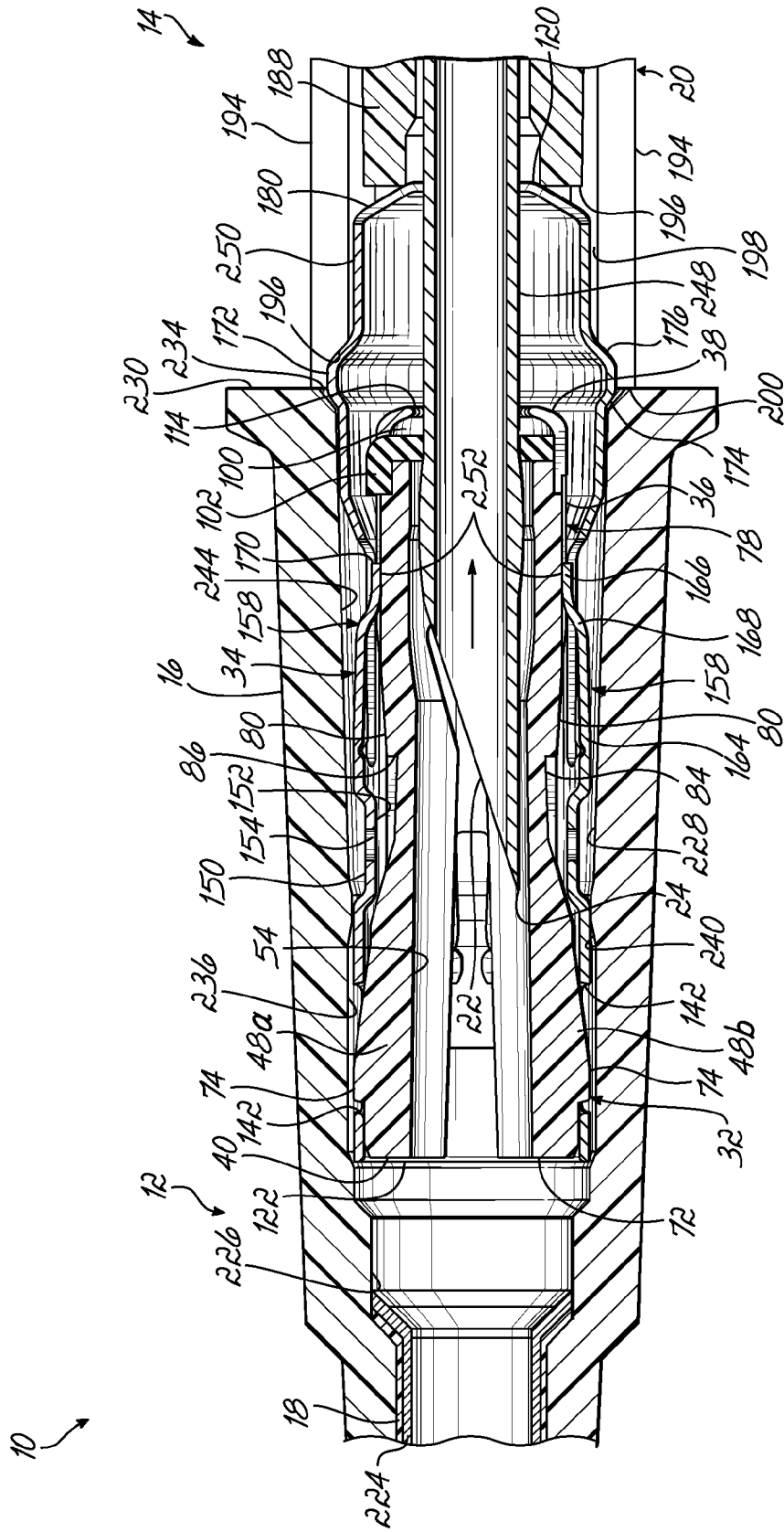

FIG. 17B

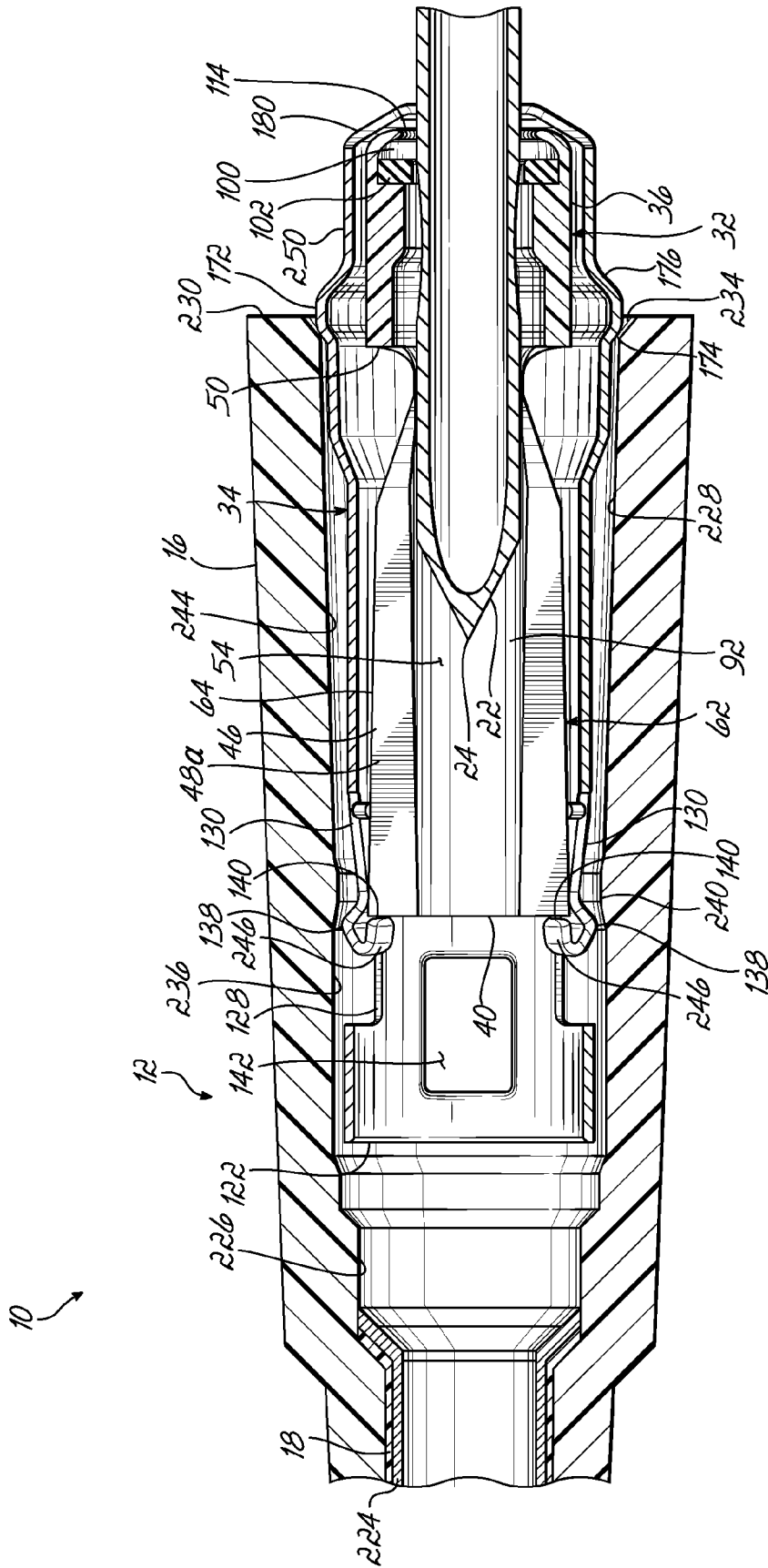

FIG. 18A

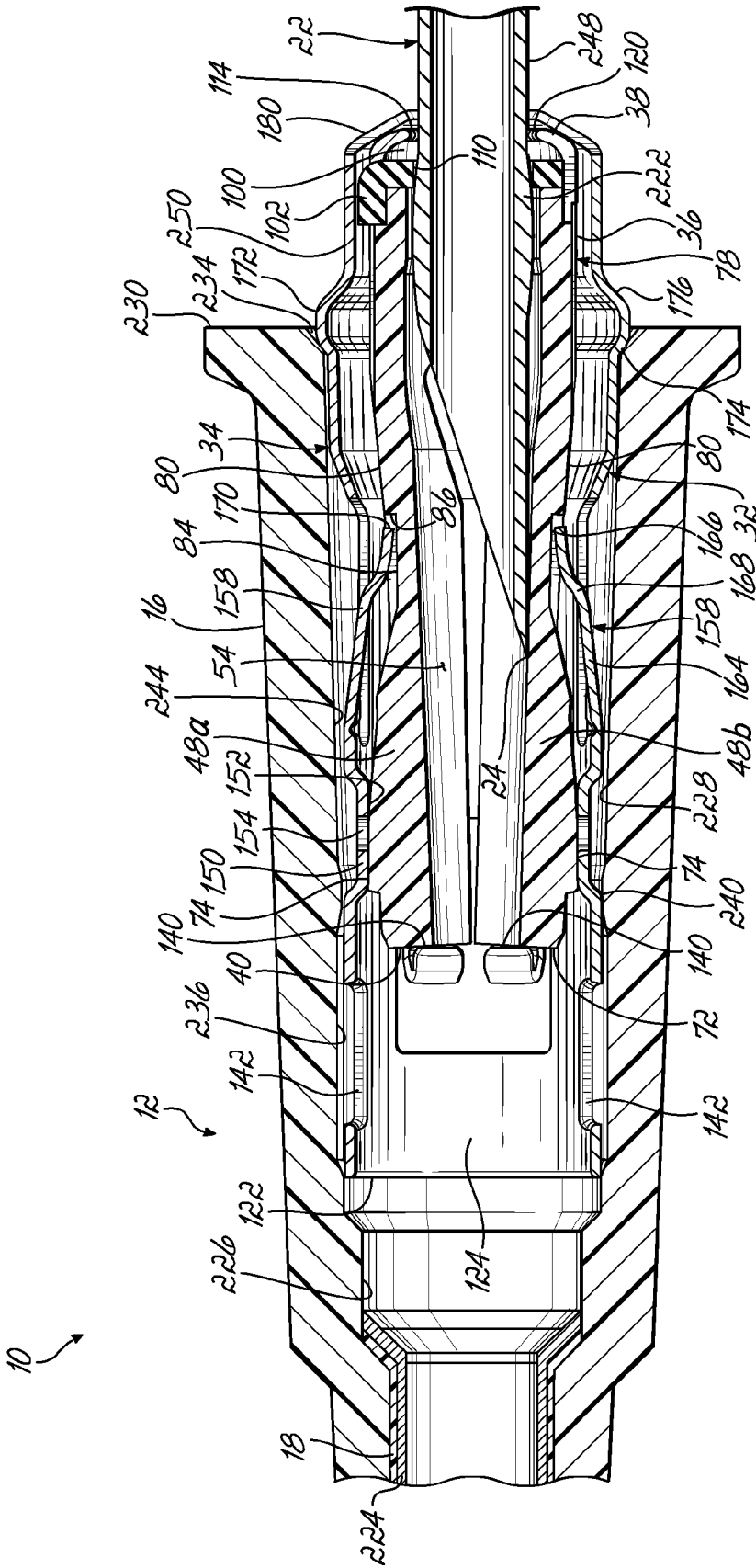

FIG. 18B

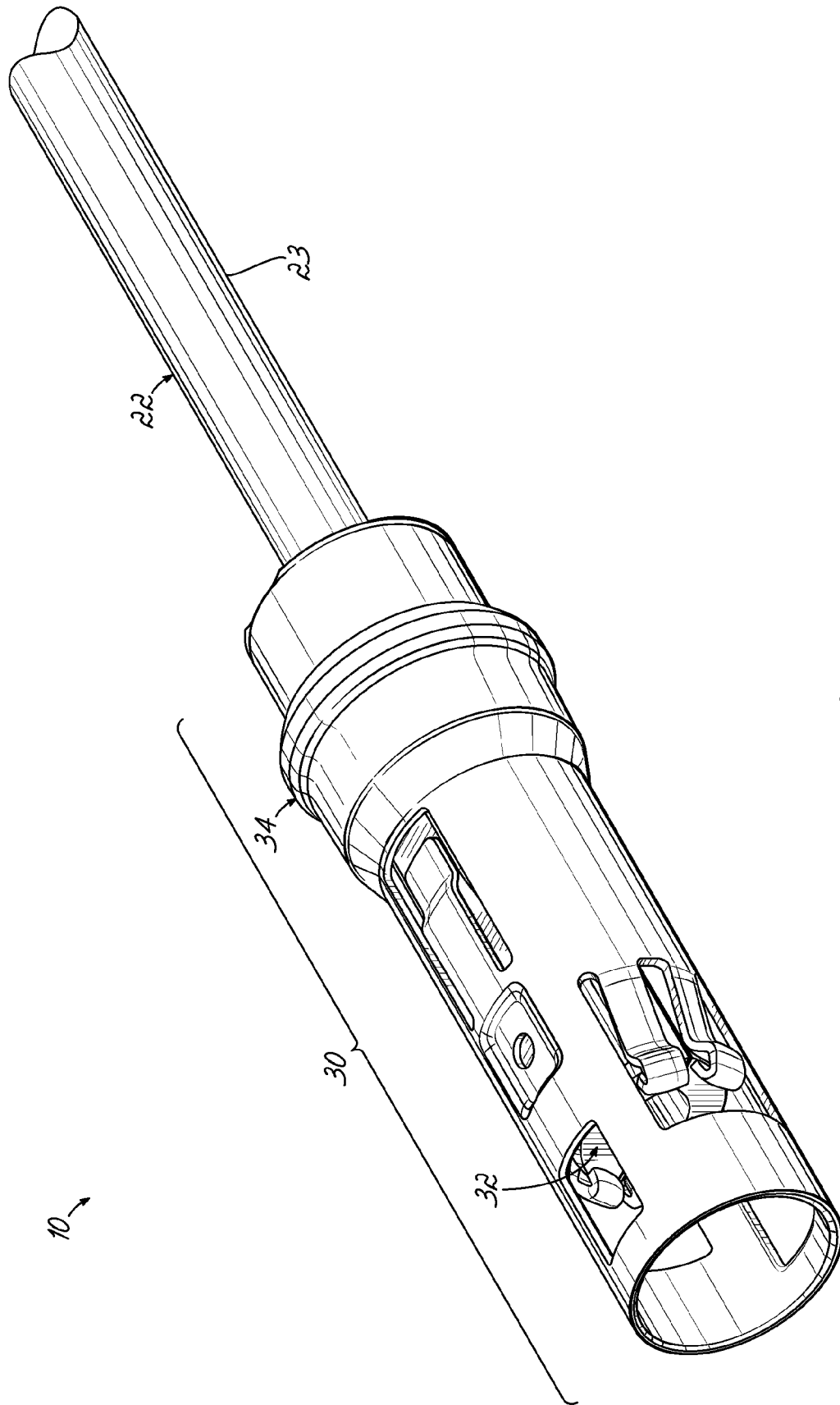
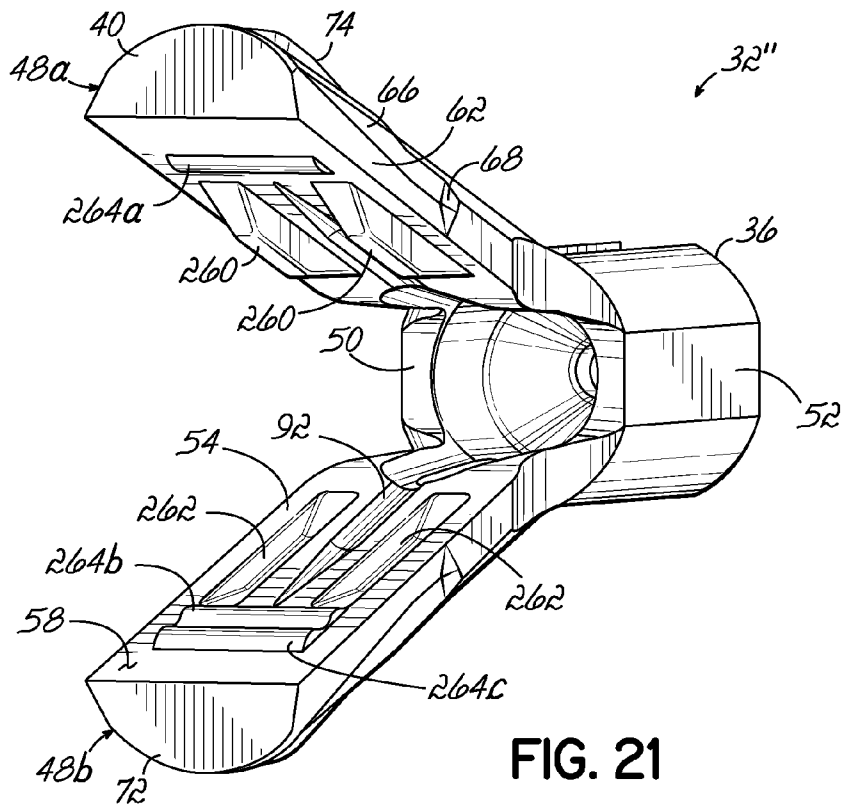
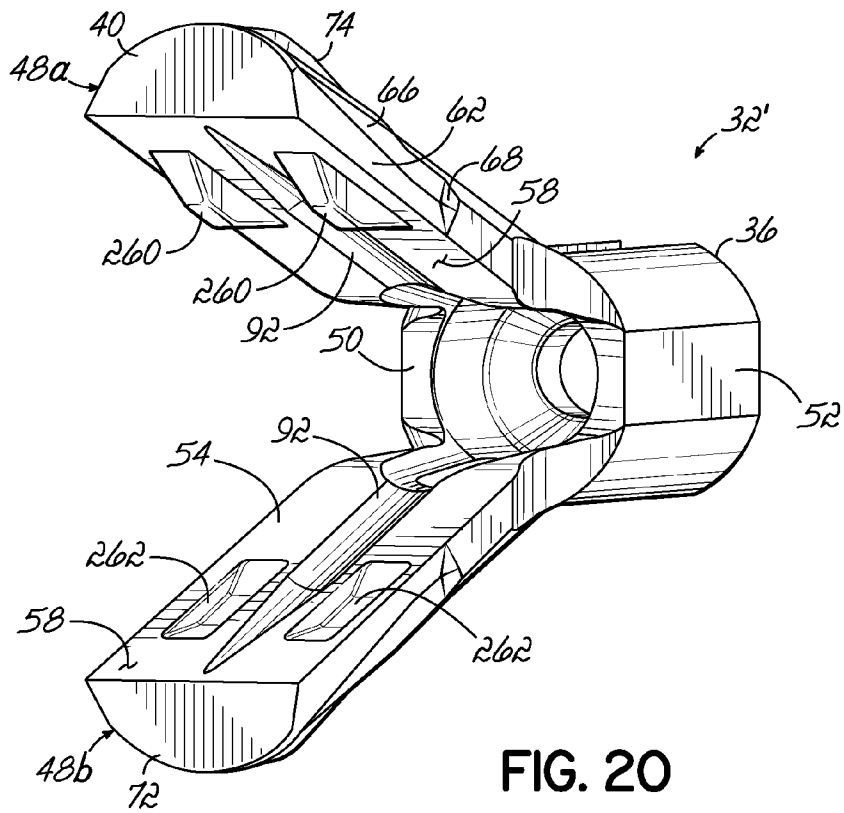

FIG. 19



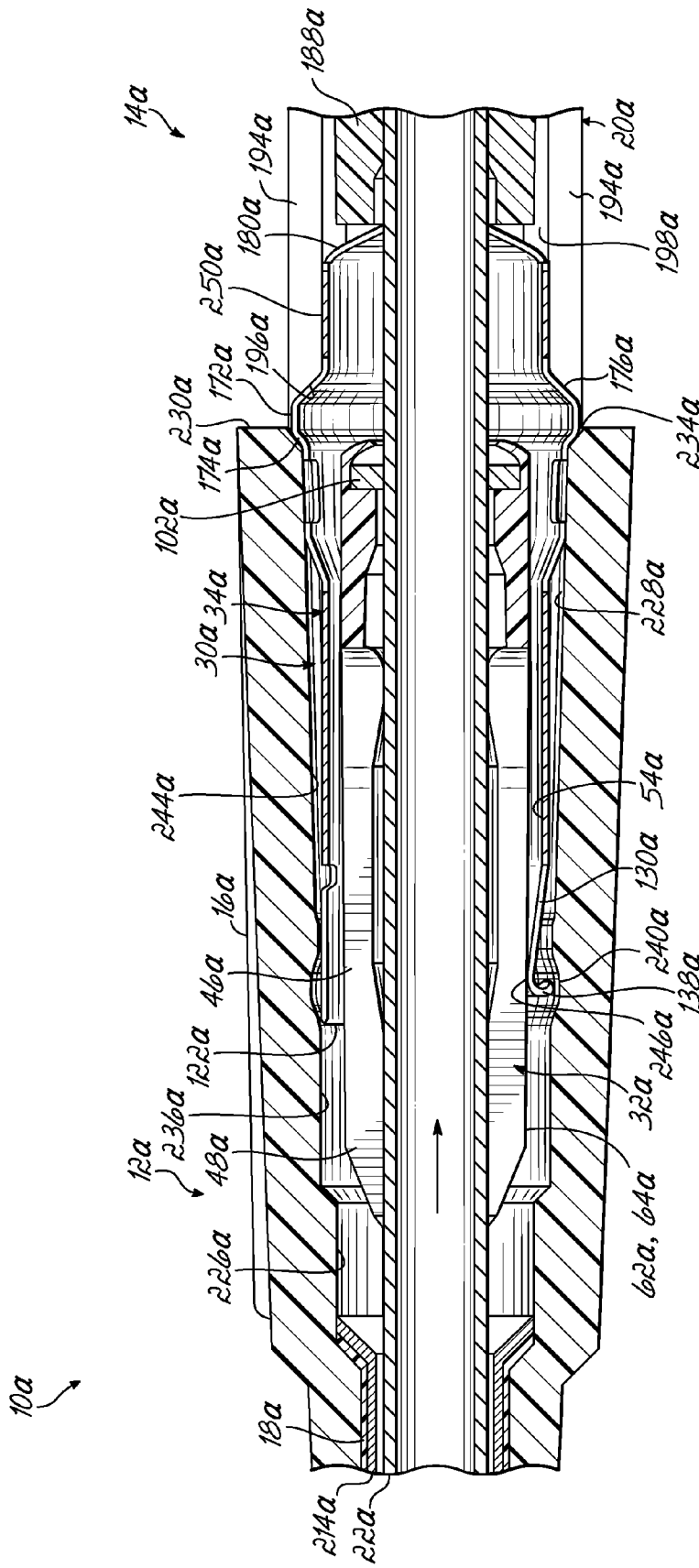

FIG. 22A

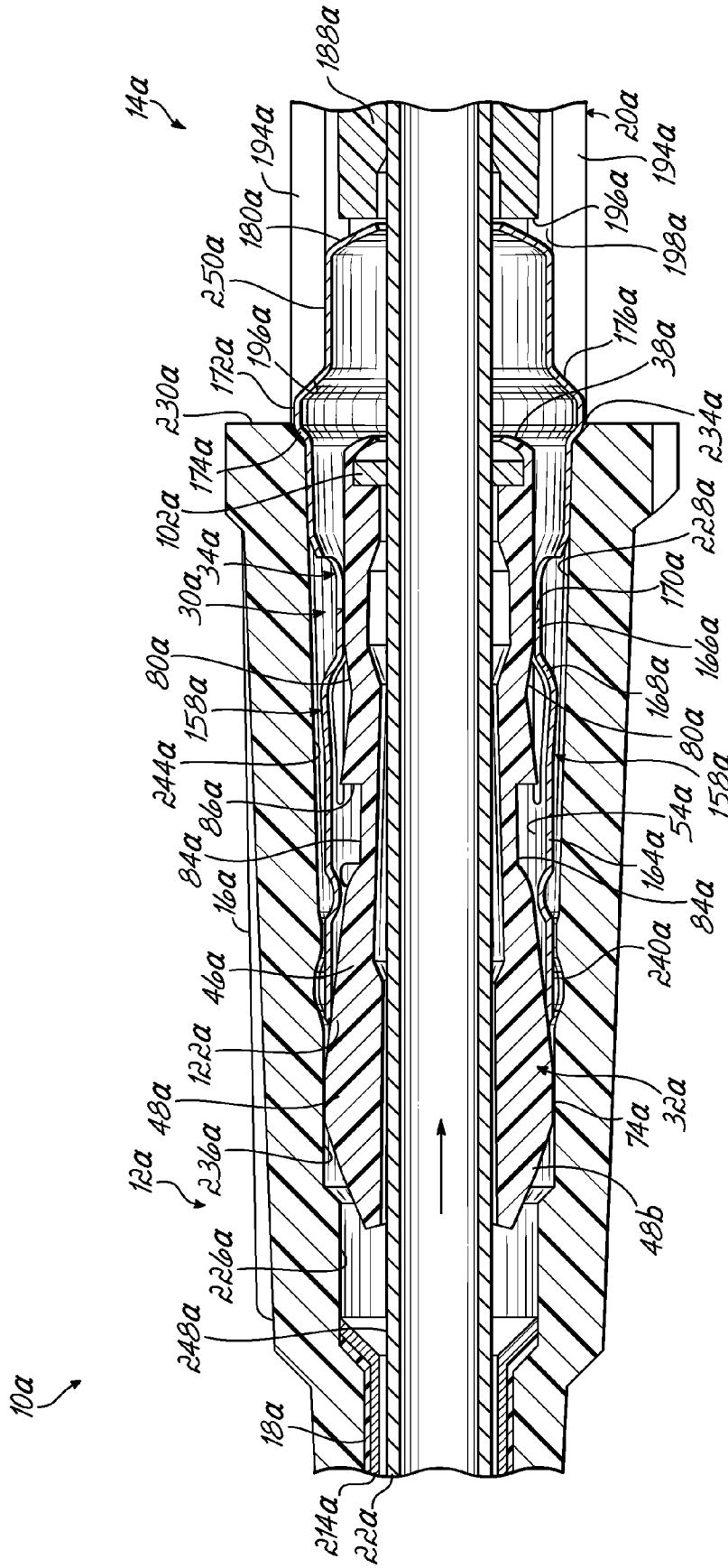

FIG. 22B

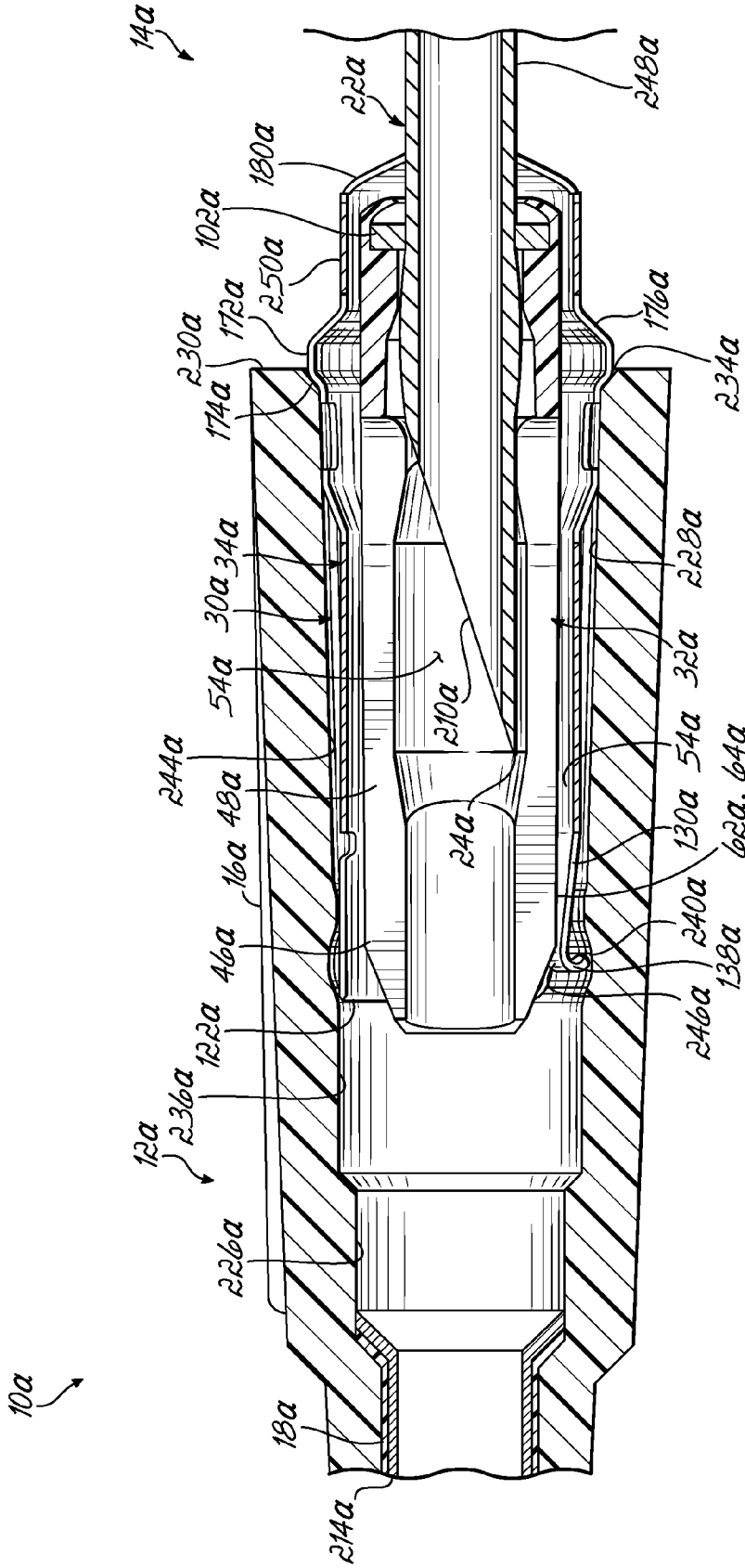

FIG. 23A

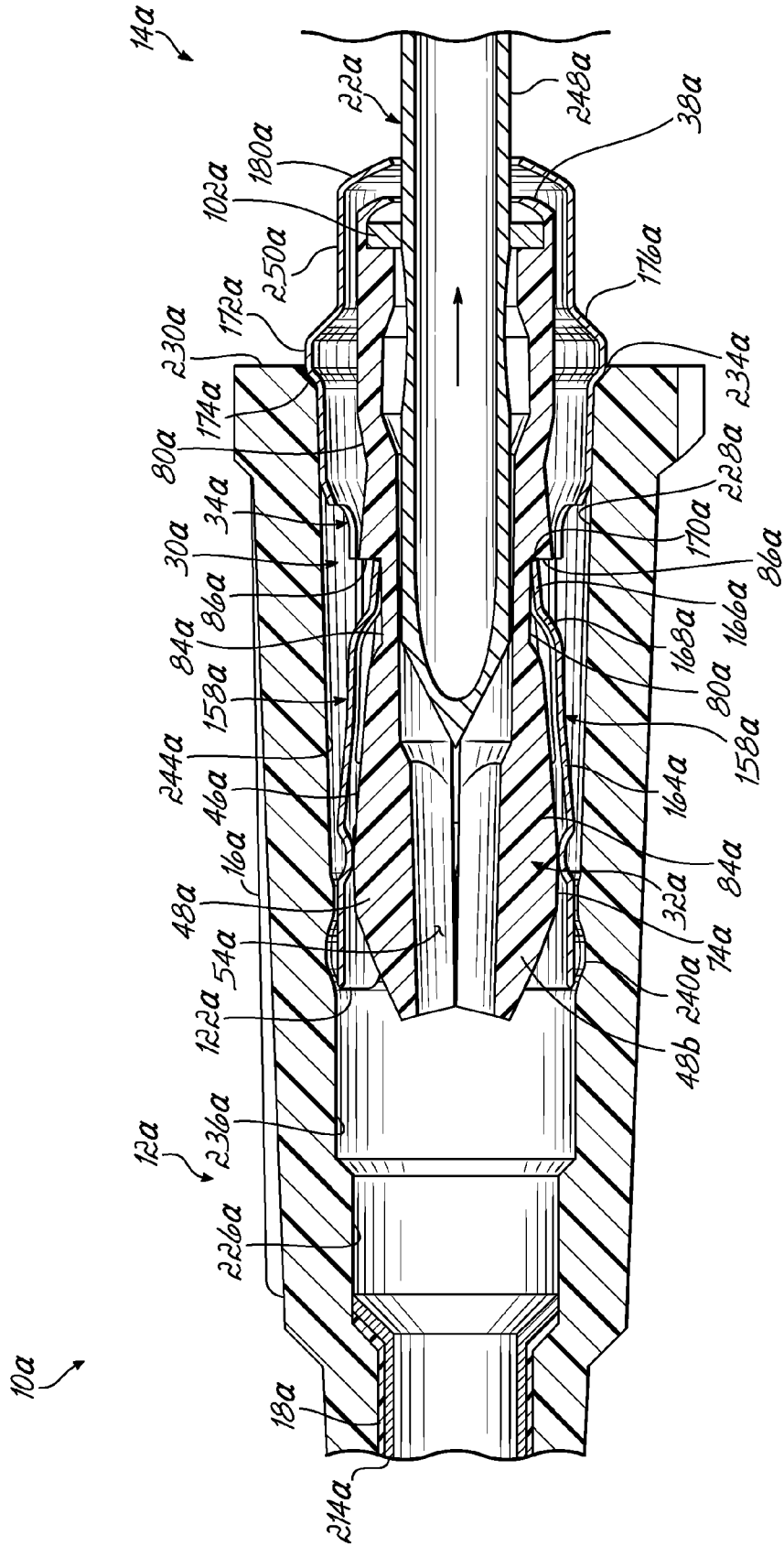

FIG. 23B

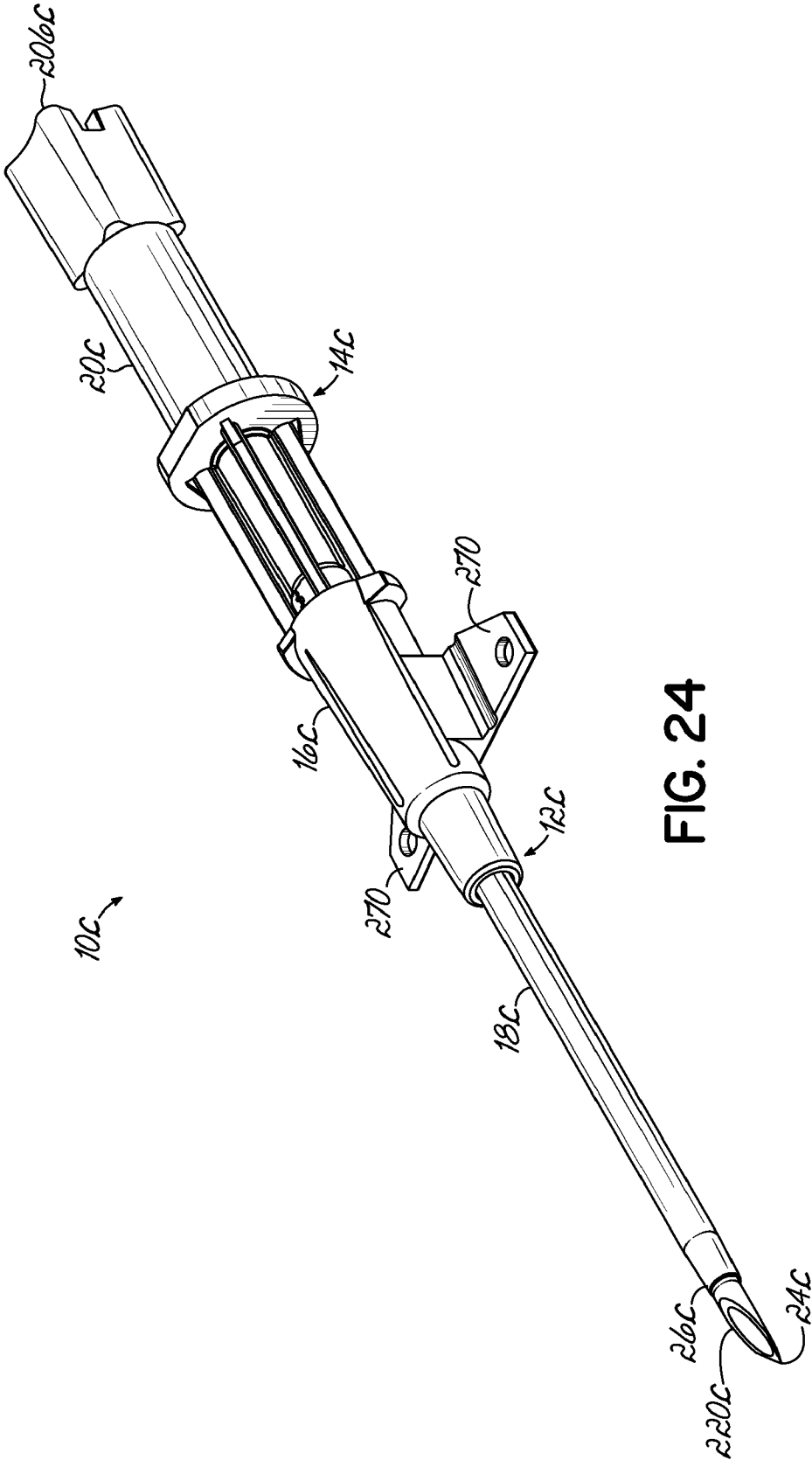

FIG. 24

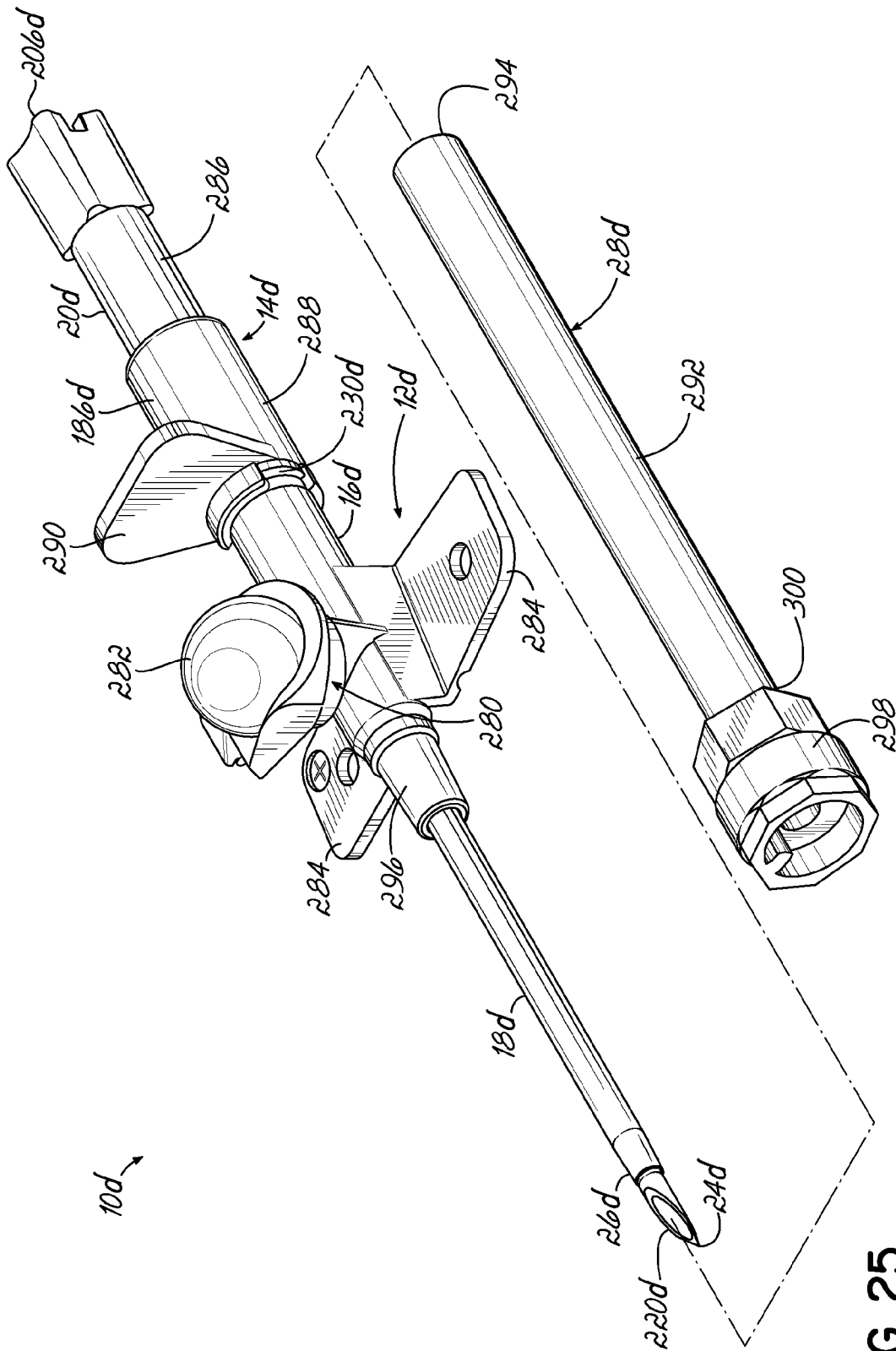

FIG. 25

TIP PROTECTOR FOR A SAFETY CATHETER

TECHNICAL FIELD

The present invention relates to safety catheters and, more particularly, to tip protectors to shield the sharp tip of the needle cannula used with the catheter.

BACKGROUND

Safety catheters are widely used and typically include a catheter hub with a catheter tube extending distally thereof to be placed intravenously, a needle hub or support with a needle cannula extending distally thereof to a sharp distal tip and extending through the catheter tube to expose the sharp tip in order to facilitate intravenous insertion of the catheter tube, and a tip protector through which at least a portion of the needle shaft passes and adapted to enclose or otherwise shield the tip of the needle cannula after it has been withdrawn from the catheter tube and into the tip protector.

One form of tip protector involves a clip that fits within the catheter hub. Such clips are readily recognized in that they are thin webs of metal or the like which are bent or otherwise formed to have a back wall and one or more distally extending walls, all generally of the same thickness. In a ready state of the clip, the needle shaft of the needle cannula passes through an aperture in the back wall of the clip and against the distally extending arm of the clip, and between the arms where there are two of them, to pass into the catheter tube in order to expose the sharp tip. The needle cannula may be pulled proximally so as to bring the sharp tip within the clip proximal of the distal end walls of the arm(s), whereupon the arms close down to block distal re-emergence of the sharp tip. Also, a protuberance or other feature of the needle shaft near the sharp tip is sized not to readily pass through the back wall aperture, such that the protuberance engages against the back wall. The sharp tip is thus considered protected by the clip, which may be thought of as the locked or fired position. Any further proximal movement of the needle cannula will pull the clip out from the catheter hub.

Portions of the clip may be urged radially outwardly into engagement with an internal feature of the catheter hub so as to secure the clip within the hub. In one form, the presence of the needle against an arm (and between two of them, if present) urges an aspect of the arm(s) radially outwardly into engagement with a rib or groove of the catheter hub. In that form of clip, when the needle tip is pulled into the clip in the fired position, closing down of the arms also causes the arm aspect to move radially inwardly and away from engagement with the catheter hub, thereby releasing the clip for easy removal from the catheter hub. That form of design may be thought of as a passive tip protector, in that the user need do little more to remove the clip from the catheter hub than pull the sharp tip into the clip. In another form, an aspect of the clip remains urged into engagement with the catheter hub even in the fired position, such that removal thereof requires application of a force to overcome the engagement, with the force being applied by tugging the needle cannula proximally to overcome the force. The latter type of design may be thought of as an active tip protector in that the user must apply the added tugging force to overcome the hold of the clip to the catheter hub in order to remove the clip.

Clips have a disadvantage in that they tend to scrape along the needle shaft as the needle cannula is pulled proximally from the ready position to the fired position. That scraping is objectionable and can be particularly problematic in the pas-

sive tip protector due to the forces involved in the needle shaft urging the arms radially outwardly into engagement with catheter hub. In the active tip protector, the forces involved between the clip arm(s) and the needle shaft can be lessened, but at the expense, in part, of requiring higher removal forces, which can be objectionable.

A couple of recent proposals have sought to separate the catheter hub engagement function of the clip from the clip protective function so as to obtain the benefit of easy removal provided by passive tip protectors with the reduced forces on the needle shaft provided by active tip protectors. Those proposals involve an outer member about the clip, with the outer member having an engagement portion held radially outwardly into engagement with the catheter hub feature by the clip in the ready position. In those proposals, a portion of the clip is adjacent the outer member engagement portion so as to limit the ability thereof to move radially inwardly and release engagement with the catheter hub. When the needle tip is brought into the clip to place the clip in the fired position, further proximal movement of the needle cannula pulls the clip proximally relative to the outer member to misalign the clip portion from the outer member engagement portion into a release position such that the engagement portion can move radially inwardly and out of engagement with the catheter hub. These proposals thus involve a clip as an inner member and an outer member thereabout, with the two being axially shiftable from the ready and fired positions to the release position.

Those proposals seemingly provide the benefits of reduced needle shaft and clip arm forces of the active tip protectors, with the ease of removal of the passive tip protectors. But they still have drawbacks and can benefit from improvements.

SUMMARY

The present invention provides safety catheters with tip protectors utilizing axially shiftable members, but which overcome drawbacks of prior proposals and improve thereon. To that end, and in accordance with a feature of the present invention, it is determined that the prior proposals required that the clip defining the inner member be partially within the axial extent of the outer member and partially exposed so as to be at least partially within the axial extent of the catheter hub distal of the outer member. In one aspect of the present invention, the tip protector has an outer member, with the engagement portion defined by one or more flexible tabs thereof which can extend radially outboard of the body of the outer member to engage the catheter hub and can move radially inwardly to release therefrom, and the inner member is sized and positioned to be completely within the axial extent of the outer member. The inner member has a portion to impede radially inward movement of the flexible tab when the inner member portion is disposed axially adjacent the flexible tab. The inner member is axially shiftable relative to the outer member between a first position wherein the distal tip, which may be a sharp tip or a blunt tip, extends distally of the tip protector and the inner member portion is disposed axially adjacent the flexible tabs so as to impede release of the outer member from the catheter hub, and a second position wherein the distal tip is within the outer member and the inner member is moved such that the inner member portion is no longer disposed axially adjacent the flexible tab such that the inner member no longer impedes release of the outer member from the catheter hub. In all positions of the inner and outer members in use, the inner member is retained completely within the axial extent of the outer member. The outer member may be in the form of a cylindrical body member, with the inner

member being a multi-thickness member that defines an outer, cylindrical periphery conforming to the interior shape of the outer member cylinder.

In accordance with another feature of the present invention, it is determined that the outer member of the prior proposals were generally plastic or other elastomeric material, and thus are relatively thick. That thickness consumes some of the valuable cross-dimensional space of the catheter hub interior, and so limits the cross-dimension of the clip. In a further aspect of the invention, the outer member is a thin-walled metal body, such that there is more interior space available for the inner member. Further, in accordance with this further aspect of the invention, the inner member is advantageously not a clip, but is instead a multi-thickness plastic molded component, which can thus take advantage of the extra interior space left open by the use of the metal body outer member. The outer member may be in the form of a cylindrical body member, with the inner member defining an outer, cylindrical periphery conforming to the interior shape of the outer member cylinder.

In a particularly advantageous form of the inner plastic member, the proximal end thereof is provided with a metal washer to define the back wall aperture. As a consequence, a protuberance of the needle cannula engages with metal rather than plastic, so as to reduce the risk of deformation of the plastic which might allow the protuberance thereat to pass through the back end of the inner member.

In accordance with a still further feature of the present invention, the arms of the inner member may define on confronting faces thereof respective portions of a tapered bore, such that as the inner member is moved into the release position, and the arms come together, the tapered bore portions cooperate to define a tapered bore, or the effect of one, which narrows down to a distal portion of a passageway that is less than the diameter of the needle cannula, so as to limit distal re-emergence of the sharp tip therefrom. In a particularly advantageous form, the inner member is a multi-thickness plastic molded component which facilitates ready formation of the tapered bore portions in each arm thereof. In some forms, notably where small diameter needle cannulae are involved, the arms may also be provided with confronting ribs distal of the needle tip that mate together in the fired and/or released positions to further reduce the likelihood of distal re-emergence of the needle tip.

In accordance with yet another feature of the present invention, clips are generally prone to what is known as side-out by which the needle cannula may re-orient in the fired position so as to project the sharp tip out from between the arms along the side(s) of the clip. Some clips have been designed with free-standing wings in an effort to provide sidewalls to the clip. In accordance with a yet further aspect of the present invention, the confronting face of the arms may be provided with one or more sidebites, comprising at least one axially extending projection on the face of one of the arms, and an axially extending notch in the face of the other arm. A sidebite interengages when the inner member is in the fired (and release) position, so as to reduce the likelihood of lateral offset of the arms and/or side-out. In a particularly advantageous form, the inner member is a multi-thickness plastic member so as to facilitate formation of the sidebite(s).

In accordance with still another feature of the present invention, it is determined that the inner member can be designed with the arms being normally urged radially outwardly, so as to significantly reduce, if not wholly, eliminate the forces between the needle shaft and the inner member during movement of the needle cannula from the ready state to the fired state. In embodiments having the confronting ribs,

the radially outward bias, in combination with the radial extent of the ribs, positions the ribs such that they do not touch the needle shaft in the ready position, thus further reducing the risk of forces between the needle shaft and the inner member.

By virtue of the foregoing, individually and in combination, there are thus provided safety catheters with tip protectors utilizing axially shiftable members, but which overcome drawbacks and improve on prior proposals of such tip protectors. These and other objects and advantages of the present invention shall be made apparent from the accompanying drawings and description thereof.

BRIEF DESCRIPTION OF THE DRAWINGS

The accompanying drawings, which are incorporated in and constitute a part of this specification, illustrate embodiments of the invention and, together with the general description given above and the detailed description of the embodiments given below, serve to explain the principles of the invention.

FIG. 1 is a disassembled perspective view of a safety catheter in accordance with one embodiment of the invention;

FIG. 2 is an assembled perspective view of the safety catheter shown in FIG. 1, but without the protective sheath;

FIG. 3 is a perspective view of the inner member of the tip protector in accordance with one embodiment of the invention;

FIG. 4 is a cross-sectional view of the inner member shown in FIG. 3 taken generally along line 4-4 in FIG. 3;

FIG. 5 is a cross-sectional view of the inner member of the tip protector taken generally along line 5-5 in FIG. 3;

FIG. 6 is a perspective view of the outer member of the tip protector in accordance with one embodiment of the invention;

FIG. 7 is a cross-sectional view of the outer member shown in FIG. 6 taken generally along line 7-7 in FIG. 6;

FIG. 8 is a cross-sectional view of the outer member shown in FIG. 6 taken generally along line 8-8 in FIG. 6;

FIG. 9 is a partial perspective view of the needle assembly in accordance with one embodiment of the invention;

FIG. 10 is a partial cross-sectional view of the needle assembly shown in FIG. 9 taken generally along line 10-10 in FIG. 9;

FIG. 11 is a partial perspective view of the needle cannula showing an engaging feature in accordance with one embodiment of the invention;

FIG. 12 is a cross-sectional view of the needle cannula shown in FIG. 11 taken generally along line 12-12 in FIG. 11;

FIG. 13 is a partial perspective view of the catheter assembly in accordance with one embodiment of the invention;

FIG. 14 is a partial cross-sectional view of the catheter assembly shown in FIG. 13 taken generally along line 14-14 in FIG. 13;

FIG. 15 is an enlarged view of the encircled portion shown in FIG. 14;

FIG. 16A is a partial cross-sectional view of the safety catheter in the ready position, wherein the inner member is in a first position relative to the outer member;

FIG. 16B is another partial cross-sectional view of the safety catheter in the ready position and 90° offset from the view shown in FIG. 16A;

FIG. 17A is a partial cross-sectional view of the safety catheter with the distal tip of the needle cannula disposed in the tip protector;

5

FIG. 17B is another partial cross-sectional view of the safety catheter with the distal tip of the needle cannula disposed in the tip protector and 90° offset from the view shown in FIG. 17A;

FIG. 18A is a partial cross-sectional view of the safety catheter in the protected position, wherein the inner member is in a second position relative to the outer member;

FIG. 18B is another partial cross-sectional view of the safety catheter in the protected position and 90° offset from the view shown in FIG. 18A;

FIG. 19 is a partial perspective view of the needle assembly with the distal tip of the needle cannula shielded by the tip protector;

FIG. 20 is a perspective view of an inner member of the tip protector in an alternative embodiment in accordance with the invention;

FIG. 21 is a perspective view of an inner member of the tip protector in a further alternative embodiment in accordance with the invention;

FIG. 22A is a partial cross-sectional view of an alternative embodiment of a safety catheter in the ready position, wherein the inner member is in a first position relative to the outer member;

FIG. 22B is another partial cross-sectional view of the safety catheter of FIG. 22A in the ready position and 90° offset from the view shown in FIG. 22A;

FIG. 23A is a partial cross-sectional view of the alternative safety catheter of FIG. 22A in the protected position, wherein the inner member is in a second position relative to the outer member;

FIG. 23B is another partial cross-sectional view of the safety catheter of FIG. 23A in the protected position and 90° offset from the view shown in FIG. 23A;

FIG. 24 is a perspective view of a safety catheter in accordance with another embodiment of the invention; and

FIG. 25 is a perspective view of a safety catheter in accordance with yet another embodiment of the invention.

DETAILED DESCRIPTION

In reference to FIGS. 1 and 2, a peripheral intravenous safety catheter 10 includes a catheter assembly 12 and a needle assembly 14 nested relative to the catheter assembly 12 and configured to provide an interface with the vasculature of a patient (not shown). The catheter assembly 12 includes a catheter hub 16 and a generally flexible catheter tube 18 coupled to a distal portion of the catheter hub 16 and extending distally thereof. The needle assembly 14 includes a needle support or hub 20 and a needle cannula 22 coupled to a distal portion of the needle hub 20 with a needle shaft 23 extending distally of the needle hub 20. As is generally conventional, the needle assembly 14 is positioned relative to the catheter assembly 12 such that the needle cannula 22 is disposed within the catheter tube 18 and a distal tip 24 thereof (which in the embodiment shown is sharp but could alternatively be blunt) extends beyond a distal end 26 of the catheter tube 18 in a ready position of the safety catheter 10, as illustrated in FIG. 2. A sheath 28 may be provided to protect the safety catheter 10 prior to use, such as during transit to and storage in a medical facility. As will be discussed in more detail below, safety catheter 10 includes an exemplary tip protector 30 in accordance with various aspects of the present invention configured to protect the distal tip 24 of the needle cannula 22 when the needle cannula 22 is withdrawn from the catheter hub 16 during use.

As illustrated in FIGS. 1 and 19, tip protector 30 is of the type configured to enclose the distal portion of the needle

6

cannula 22, including the distal tip 24, while leaving the more proximal portions of the needle shaft 25 exposed. In accordance with one aspect of the invention, the tip protector 30 is a multi-piece design having axially shiftable members that cooperate in a manner to provide improved shielding of the distal tip 24 of the needle cannula 22, and provide improved securement/release of the tip protector 30 to and from the catheter hub 16. Additionally, as illustrated in FIG. 2, the tip protector 30 may also be of the type configured to be positioned substantially within the catheter hub 16, but as shown herein advantageously has a relatively small portion extending proximally outside thereof.

To this end, the tip protector 30 includes a first, inner member 32 received within a second, outer member 34 such that the inner member 32 is axially shiftable relative to the outer member 34 between a first position and a second position, as will be explained in more detail below. In accordance with one aspect of the invention, the inner member 32 may be designed with the primary focus of protecting or shielding the distal tip 24 of the needle cannula 22. This may be achieved, for example, by blocking the path of the needle cannula 22 once the inner member 32 has been axially shifted to the second position. The outer member 34, on the other hand, may be designed with the primary focus of securing and releasing the tip protector 30 to and from the catheter hub 16. While the particular functions of the tip protector 30 may be parsed out to, for example, the inner and outer members 32, 34, it should be recognized that both members 32, 34 are necessary to provide a tip protecting function in the safety catheter 10.

In one embodiment, and as illustrated in FIGS. 3-5, the inner member 32 includes a generally cylindrical body member 36 having a proximal end 38, a distal end 40, and a passageway 42 extending between the proximal and distal ends 38, 40. Passageway 42 defines a central axis 44 and is configured to receive at least a portion of the needle cannula 22 therethrough. The cylindrical body member 36 includes a pair of opposed slots 46 formed through the wall of the body member 36 to define a pair of opposed arms 48a, 48b capable of hinging generally inward and outward relative to the central axis 44. In that regard, the slots 46 intersect the distal end 40 of the body member 36 and extend proximally therefrom. The slots 46 have a proximal end 50 that stop short of the proximal end 38 of the body member 36 to define a generally circumferentially continuous base member 52. To facilitate hinging of the arms 48a, 48b, the width of the slots 46 may vary along their length so as to, for example, increase in width adjacent to and in a direction toward the proximal end 50 of the slots 46, as shown in FIGS. 3 and 4, which operates as the hinge or pivot point for arms 48a, 48b.

In one embodiment, and although not so limited, the arms 48a, 48b may be essentially mirror images of each other, and thus a description of one of the arms (e.g., arm 48a) will suffice as a description of the other arm (arm 48b). Arm 48a includes an inner surface 54, an outer surface 56, and a pair of slot faces 58 formed by the formation of slots 46 in body member 36. The outer surface 56 may be contoured to facilitate operation of the tip protector 30. To this end, the outer surface 56 may include a first angled surface 60 adjacent each of the slot faces 58 and adjacent the proximal end 50 of the slots 46. A groove 62 may also be formed adjacent each of the slot faces 58 and includes a bottom wall 64, a side wall 66, and a proximal end wall 68 (FIG. 3). The groove 62 extends distally from the first angled surface 60 toward the distal end 40 of the arm 48a and is open along a distal end thereof. Additionally, at least a portion of the distal end 40 of the arm

48a may include a slight chamfer **70** formed in the outer surface **56** thereof which leads to a distal end face **72** of the arm **48a**.

As shown in FIGS. 3 and 4, the outer surface **56** of arm **48a** may include a raised ridge or boss **74** disposed adjacent the distal end **40** and along an intermediate portion of arm **48a** (e.g., generally central of the two grooves **62** and, for example, about ninety degrees offset relative to slots **46**). The raised boss **74** defines abutment surfaces **76**, the purpose of which is described in more detail below. Moreover, arm **48a** may include a second groove **78** formed along an intermediate portion of arm **48a** (e.g., generally aligned with raised boss **74**) that has a proximal end adjacent the proximal end **38** of body member **36**, and a distal end that terminates in arm **48a** proximal of raised boss **74**. Groove **78** includes a bottom wall **80**, and a pair of opposed side walls **82**. The groove **78** may have a depth that varies along its length and may further have a cavity **84** formed in the bottom wall **80** thereof. Cavity **84** defines a first end wall **86** and a second end wall **88**. In one embodiment, the first end wall **86** may generally form an acute or right angle relative to bottom wall **80**, and the second end wall **88** may generally form an obtuse angle relative to the bottom wall **80**. In addition to the above, the outer surface **56** of the inner member **32** may include a notch **90** formed adjacent the proximal end **38** and which extends into (e.g., recessed in) the bottom wall **80** of the groove **78**.

The inner surface **54** of the inner member **32** may also be contoured to facilitate operation of the tip protector **30**. As shown in FIGS. 3 and 5, the inner surface **54** of arm **48a** includes a generally smooth distal tapered bore portion **92**. In other words, the distal tapered bore portion **92** includes a generally defined radius of curvature that decreases in the distal direction (i.e., toward distal end **40**). Collectively, the tapered bore portions **92** of both arms **48a** and **48b** define a tapered bore that is a portion of passageway **42** which has a first cross dimension at a first proximal location and a second cross dimension at a second distal location that is less than the first cross dimension, at least when the inner member **32** is in its second position relative to outer member **34**, as explained in more detail below.

In addition to the above, an inner surface **94** of base member **52** may include an annular rib **96** that generally defines a proximal facing ledge **98**. While the embodiment shown in FIGS. 3-5 illustrates a single rib that provides a continuous circumferential ledge, in alternative embodiments, multiple ribs may be utilized to provide a discontinuous ledge (not shown). The ledge **98** generally defines at least in part the boundary of a proximal cavity **100** configured to receive a needle stop member therein. As discussed in more detail below, the stop member may be configured to cooperate with the needle cannula **22** during its withdrawal from the catheter assembly **12** so as to effect relative movement between the needle cannula **22** and the tip protector **30**.

In an exemplary embodiment, the stop member may include a stop washer **102** having a distal face **104**, a proximal face **106**, a side wall **108** extending between the distal and proximal faces **102**, **104**, and a central aperture **110** also extending between the distal and proximal faces **102**, **104** (FIG. 3). The stop washer **102** is generally characterized by the length "l" of the side wall **108** being less than, and preferably significantly less (such as about $\frac{1}{3}$ to $\frac{1}{2}$) than a cross-dimension "c" (e.g., diameter or effective diameter) of the distal and proximal faces **104**, **106**. As also illustrated in FIG. 3, in one embodiment, the stop washer **102** may include at least one leg **112** (one shown) coupled to the side wall **108** and extending distally thereof. While the stop washer **102** is advantageous in many applications, other stop members may

be used including, for example, a tubular sleeve. However, a sleeve is axially elongated as compared to a washer and may have certain drawbacks that may not be desirable in certain applications.

When the stop washer **102** is positioned within proximal cavity **100**, the distal face **104** thereof is configured to engage the ledge **98** formed by the rib **96**. This engagement prevents or limits distal movement of the stop washer **102** relative to the inner member **32**. The stop washer **102** may be captured within cavity **100** by suitable formation of the proximal end **38** of the body member **36**. To this end, the proximal end **38** includes a proximal end face **114** having an opening **116** formed therein. The opening **116** has a cross dimension (e.g., diameter) that is smaller than a cross dimension of the stop washer **102**. Accordingly, the end face **114** operates to prevent or limit proximal movement of the stop washer **102** relative to the inner member **32**.

In addition to the above, when the stop washer **102** is disposed within proximal cavity **100**, the leg **112** is configured to be received within the notch **90** formed adjacent the proximal end **38** of the body member **36**, as illustrated in FIG. 4. The purpose of the leg **112** (and thus the notch **90** that receives leg **112**) is primarily directed to facilitating assembly of the safety catheter **10** through an automated manufacturing process. The leg **112** and notch **90** otherwise have no role in the proper functioning of the tip protector **30**. Accordingly, those of ordinary skill in the art will realize that the leg **112** and the notch **90** that receives the leg in an assembled condition may be omitted without negatively affecting the operation of the safety catheter **10** depending on the particular requirements or preferences of an assembly process.

The body member **36** of inner member **32** may be formed from suitable materials including various metals and plastics. By way of example, the body member **36** may be formed from such materials as polypropylene, polyethylene, polyoxymethylene (acetal), polycarbonate and nylon. In one aspect, the body member **36** may be formed from plastics or other materials suitable for molding processes including, for example, various injection molding processes. In an exemplary embodiment, the inner member **32** may be formed from plastic through a molding process so as to define the multi-thickness member shown herein. The stop washer **102** may also be formed from suitable materials including various metals and plastics. The stop washer **102** may be generally more rigid than the body member **36** and advantageously may be formed from medical grade stainless steel or other metals. In this regard, the use of a more rigid material at the location of engagement between the needle cannula **22** and the inner member **32** reduces the risk of the plastic inner member from deforming and allowing the needle cannula **22** to be pulled from the tip protector **30**.

The stop washer **102** may be assembled with the body member **36** during manufacturing or during a post-manufacturing process of inner member **32**. By way of example, the stop washer **102** may be assembled with body member **36** in an over-molding process. In that regard, the stop washer **102** may be suitably located within a mold assembly as an insert. The mold assembly is then closed and the resin that forms the body member **36** is injected into the mold so as to form about the insert. In another embodiment, the body member **36** may be injection molded without the stop washer **102** being assembled therewith. In this method, the proximal end **38** thereof may lack the proximal end face **114** and instead be formed as an open ended tubular extension of cavity **100** (FIG. 3). Subsequent to the molding operation of body member **36**, the stop washer **102** may be positioned within the cavity **100** and the proximal end **38** processed to form proximal

mal end face **114**. By way of example, a swaging or other similar process may be utilized to form the proximal end face **114**. Those of ordinary skill in the art may recognize other processes for manufacturing and/or assembling the inner member **32** and aspects of the invention are not limited to those described herein.

Turning to the outer member **34** illustrated in FIGS. 6-8, in one embodiment, the outer member **34** includes a body member **118** which is shown here to be a thin-walled generally cylindrical body member **118**. Body member **118** has a proximal end **120**, a distal end **122**, and a passageway **124** extending between the proximal and distal ends **120**, **122**. The passageway **124** defines a central axis **126** and is configured to receive at least a portion of the inner member **32** as well as at least a portion of the needle cannula **22**. When the inner and outer members **32**, **34** are movably coupled in the manner described below, the central axes **44**, **126** may be configured to be generally colinear. Outer member **34** includes a number of features that facilitates operation of tip protector **30** through cooperation with the inner member **32** as well as with the catheter hub **16**.

In that regard, cylindrical body member **118** includes a pair of opposed, generally rectangular openings or cutouts **128** formed through the wall of the body member **118** adjacent, but spaced from, the distal end **122** thereof. In one embodiment, engagement portions in the form of at least one generally flexible tab **130** may be generally disposed in one or each of the cutouts **128**. For example, in one embodiment, two tabs **130** may be generally disposed in each of the cutouts **128**, as shown in FIGS. 6 and 7. In an alternative embodiment, however, one tab **130** may be generally disposed in each of the cutouts **128** (not shown). In a further alternative embodiment, one or two flexible tabs **130** may be generally disposed in only one of the cutouts **128**. Other combinations may also be possible. Each of the flexible tabs **130** has a J-shaped configuration with a proximal end **132** thereof coupled to a proximal end **134** of a corresponding cutout **128**.

In one embodiment, a distal end **136** of the flexible tabs **130** may be curved or hooked in a generally inward direction relative to central axis **126** so as to define an abutment surface **138** on an outer surface of the tabs **130** and terminate along a contacting edge **140** inward of the abutment surface **138** (FIG. 8). While the flexible tabs **130** are shown as being curved or hooked in a generally inward direction, in an alternative embodiment, the flexible tabs **130** may be curved or hooked in a generally outward direction relative to central axis **126** such that the contacting edge **140** is directed outwardly (not shown). As will be explained in more detail below, the flexible tabs **130** may extend radially outward of the cylindrical body member **118** so as to cooperate with the catheter hub **16** and releasably secure the tip protector **30** thereto.

In addition to cutouts **128**, the outer member **34** may include at least one, and preferably a second pair of opposed, generally rectangular openings or cutouts **142** formed through the outer wall of the body member **118** adjacent, but spaced from, the distal end **122** thereof. In one embodiment, the cutouts **142** may be about ninety degrees offset from the cutouts **128** (e.g., about central axis **126**) and may be located slightly distally of cutouts **128**, although not so limited. Cutouts **142** define a proximal edge **144**, a distal edge **146**, and a pair of side edges **148** (FIG. 8). As will be explained in more detail below, the cutouts **142** are configured to receive the raised bosses **74** on the inner member **32** when the safety catheter **10** is in the ready position.

The outer member **34** may further include at least one, and preferably a pair of opposed, generally rectangular indentations **150** formed in the outer wall of the body member **118**.

The indentations **150** may be generally axially aligned with cutouts **142** (e.g., about ninety degrees offset from the cutouts **128**) and positioned proximally thereof. As can be appreciated, the indentations **150** formed on the outer surface of body member **118** result in projections relative to the inner surface of the body member **118** that defines engaging surfaces **152** that extend away from an inner surface and into the passageway **124** of the outer member **34**. The indentations **150**, in effect, define a reduced cross dimension portion of passageway **124** and are configured to cooperate with the inner member **32** in a manner to be described in more detail below. A hole **154** may be formed in at least one of the indentations **150**. Similar to above, the hole **154** plays no role in the functioning of tip protector **30**. Instead, hole **154** may facilitate assembly, such as providing a visual aid during the assembly process of the catheter device **10**. Again, depending on the particular assembly process, the hole **154** may be omitted without negatively impacting the operation of tip protector **30**.

In addition to the above, the outer member **34** may include at least one, and in an exemplary embodiment, a pair of opposed slots **156** in body member **118** which extend in a generally proximal-distal direction and are generally axially aligned with the cutouts **142** and indentations **150** of outer member **34**. The slots **156**, however, may be positioned generally proximally of indentations **150**. A generally flexible locking tab **158** may be generally disposed in the at least one slot **156**, and preferably in each of the slots **156**. In that regard, the flexible locking tabs **158** may be coupled to a distal end **160** of the slots **156** and extend proximally, but stop short of the proximal end **162** of slots **156**. Each of the flexible locking tabs **158** may include a distal tab portion **164**, a proximal tab portion **166**, and an intermediate tab portion **168**. The distal tab portion **164** may be configured to generally lie within the slot **156** (e.g., within the perimeter of the outer member **34**), although not so limited. The intermediate tab portion **168**, however, may be generally arcuate so as to define an offset between the distal tab portion **164** and the proximal tab portion **166**. In this regard, the proximal tab portion **166** may be positioned generally inward of distal tab portion **164** relative to central axis **126** of outer member **34** so as to project into passageway **124**. The proximal tab portion **166** terminates in a contacting edge **170**, the purpose of which is to be described in more detail below.

Adjacent the proximal end **120** of outer member **34** is a generally outwardly extending flange **172**. In one embodiment, the flange **172** is circumferentially continuous (e.g., annular). In an alternative embodiment, the flange **172** may be circumferentially discontinuous and define one or more flange portions that project generally outwardly from body member **118** (not shown). Flange **172** defines a generally distally-facing lip **174** and a generally proximally-facing lip **176**. As discussed in more detail below, the flange **172** may be configured to cooperate with the catheter hub **16** during use. The flange **172** may also be configured to cooperate with the needle hub **20**, as discussed below. The proximal end **120** of body member **118** may further include a generally cylindrical extension portion **178** proximal of the flange **172**. The extension portion **178** terminates in a generally conical proximal end face **180** having an opening **182** configured to receive at least a portion of the needle cannula **22** therethrough. In one embodiment, the proximal end face **180** may be formed by a plurality of inwardly directed tabs **184** (four shown) that define the opening **182**.

The cylindrical body member **118** of outer member **34** may be formed from suitable materials including various metals and plastics. In an advantageous aspect, the body member **118**

11

may include a thin-walled cylinder formed from sheet stock metals capable of being formed into a generally cylindrical member. Such metals include medical grade stainless steels (e.g., 410 stainless steel, 17-7 stainless steel, etc.) with or without heat treatment or other processing to achieve a suitable hardness or other desired characteristics. In an exemplary embodiment, the outer member **34** may be formed through a stamping process of the sheet stock, which stamped material is then put through a rolling process to form the outer member **34**. The edges of the rolled material may then be joined through a suitable process including welding, bonding or other process. In one embodiment, the edges may include interlocking features to enhance the securement of the edges to form the cylindrical body (e.g., a zipper configuration). Those of ordinary skill in the art may recognize other processes for forming outer member **34** or for coupling the edges to form a generally cylindrical shape. In contrast to previous designs, the outer member **34** has a thin-walled (but sufficiently strong) design that provides increased space for the inner member (e.g., bulkier, plastic inner member).

As described above, the needle assembly **14** generally includes needle hub **20** and needle cannula **22** coupled to a distal portion of needle hub **20** with a needle shaft **23** extending distally thereof. As shown in more detail in FIGS. **9** and **10**, the needle hub **20** may include a generally cylindrical body member **186** having a distal nose **188**, a proximal tubular portion **190**, and a generally outwardly extending intermediate flange **192** disposed therebetween. The distal nose **188** may be configured to receive therein and secure thereto a proximal portion of the needle cannula **22**. The distal nose **188** may further include a plurality of circumferentially spaced spines **194** (four shown) that extend in a generally proximal-distal direction therealong. The spines **194** provide increased strength to the needle hub **20** and may further facilitate assembly of the safety catheter **10**. At least one, and preferably each of the spines **194** extends beyond a distal end **196** of nose **188** to define an inner surface **198** and a generally distally-directed end face **200**. Additionally, a distal end of inner surface **198** may include a taper or bevel **202**.

The proximal tubular portion **190** defines an interior chamber **204** that is in fluid communication with a lumen of the needle cannula **22** such that the chamber **204** may operate as a flash chamber for the safety catheter **10**, as is generally known in the art. A flash plug **206** closes off the chamber **204** and is configured to allow gases to pass therethrough while retaining liquid, such as blood and other bodily fluids, within chamber **204**. In one embodiment, an outer surface **208** of the proximal tubular portion **190** is generally smooth. In an alternative embodiment, however, the outer surface **208** may include grip-enhancement features, such as various depressions or projections that facilitate gripping of the needle hub **20** by a user (not shown). In such a case, the ridges **210** on flash plug **206** may be oriented relative to the proximal tubular portion **190** so as to generally axially align with any such grip-enhancement features.

The intermediate flange **192** may be generally disposed between and extend generally outwardly of the distal nose **188** and the proximal tubular portion **190**. In one embodiment, intermediate flange **192** may be generally disc-shaped and include a distal end face **212** and a proximal end face **214**. The spines **194** on distal nose **188** may extend from distal end face **212**, as shown. In one aspect, the intermediate flange **192** may be configured to cooperate with the sheath **28** that protects the safety catheter **10** during transit and storage. In that regard, the proximal opening **216** in sheath **28** (FIG. **1**) may include one or more tabs (not shown) that provide a snap-fit feature between the needle hub **20** and sheath **28**. More par-

12

ticularly, when the needle hub **20** is inserted into the sheath **28**, the tabs at proximal opening **216** may be configured to engage the proximal end face **214** of intermediate flange **192** to secure the more distal portions of needle assembly **14** (and the catheter assembly **12** as well) within the sheath **28**.

As shown in these figures, the needle cannula **22** includes a generally straight, cylindrical and smooth needle shaft **23**, a distal portion of which includes a bevel **220** that defines distal tip **24** to be sharp. The needle cannula **22** may be formed from suitable medical grade materials, such as stainless steel or other suitable materials, and the bevel **220**/distal tip **24** may be formed in shaft **23** through conventional processes generally known in the art. However, as best illustrated in FIGS. **1**, **11** and **12**, the needle cannula **22** may include an engagement feature adjacent a distal end thereof configured to cooperate with the inner member **32** to axially shift the inner member **32** from the first position to the second position relative to the outer member **34**, as discussed below. In one exemplary embodiment, the engagement feature includes a protuberance **222** adjacent a distal end of the needle cannula **22** and proximal of bevel **220**.

For reasons that will become clearer below, the protuberance **222** defines a cross dimension that is greater than a cross dimension of the needle shaft **23** proximal of the protuberance **222**. In one embodiment, the protuberance **222** may be formed through a pressing or pinching process. To this end, opposed pressing members (not shown) may press against the needle shaft **23** so as to generally decrease a cross dimension thereof in a first transverse direction t_1 . As illustrated in FIG. **12**, the pressing of the needle shaft **23** in the first transverse direction t_1 causes a corresponding bulge or increase in a cross dimension of the needle shaft **23** in a second transverse direction t_2 , which may, for example, be about ninety degrees offset from the first transverse dimension t_1 . The pressing process described above is only one exemplary method for forming the protuberance **222** on needle cannula **22**. Those of ordinary skill in the art may recognize other processes that result in a protuberance **222** having a cross dimension that is greater than a cross dimension of the needle shaft **23** proximal thereof. The engagement feature may be integrally formed with needle cannula **22** (such as described above) or may be formed by fixing a separate element to the needle shaft **23**. For example, a ring member (not shown) may be welded, bonded or otherwise secured to needle shaft **23** to form protuberance **222**.

As shown in more detail in FIGS. **13-15**, the catheter assembly **12** includes a catheter hub **16** and a catheter tube **18** coupled to a distal portion of catheter hub **16** and extending distally thereof. For example, as is generally known in the art, the proximal end of the catheter tube **18** may be coupled to a metal eyelet **224**, which eyelet **224** is then press fit within a distal cavity **226** of the catheter hub **16**. The catheter hub **16** defines a proximal cavity **228** open to the proximal end **230** thereof and having a first proximal portion **232** which may be shaped according to Luer taper standards. The first proximal portion **232** may include a bevel or chamfer **234** immediately adjacent proximal end **230**. In one embodiment, the proximal cavity **228** may include a second proximal portion **236** having a generally constant cross dimension that is generally greater than (e.g., increased inner diameter) a cross dimension of the first proximal portion **232** adjacent the second proximal portion **236**. The second proximal portion **236** may be defined at least in part by a transition region **238**, as illustrated in FIG. **15**.

As best shown in FIGS. **14** and **15**, the transition region **238** defines a retention feature for releasably securing the tip protector **30** to the catheter hub **16**. In one embodiment, the

retention feature defines a generally outwardly extending retention groove **240** formed therein and may be circumferentially continuous (e.g., an annular groove). In an alternative embodiment, however, the groove **240** may be circumferentially discontinuous (e.g., circumferential groove segments). In still a further embodiment, the proximal cavity **228** may include a single proximal portion **232** that tapers or is otherwise shaped (according to any applicable standards) in a continuous manner from the proximal end **230** (or the end of chamfer **234**) to the distal cavity **226** (e.g., no second proximal portion **236** or transition region **238**) wherein the retention groove **240** is formed within the side wall of the single proximal portion **232** (not shown). Still further, the retention feature in the catheter hub **16** may have other configurations, including, for example, a circumferentially continuous or discontinuous generally inwardly extending retention rib (not shown).

With each of the elements of the safety catheter **10** described above, assembly of the safety catheter **10** will now be described in more detail. In the initial processing steps, the needle assembly **14** and catheter assembly **12** may be formed using methodologies generally known in the art. To that end, and as explained above, the proximal end of the needle cannula **22** may be press fit or otherwise coupled with the distal nose **188** of the needle hub **20**, and the proximal end of the catheter tube **18** may be secured to eyelet **224**, and the eyelet **224** secured within the distal cavity **226** of the catheter hub **16**. The flash plug **206** may also be inserted into the proximal end of proximal tubular portion **190** of needle hub **20** so as to close off the interior chamber **204**. It should be noted that as initially assembled, the needle cannula **22** does not have protuberance **222** or other engagement feature formed therein or coupled thereto.

In some applications, it may be desirable to orient the needle cannula **22** and needle hub **20** in a specific manner. By way of example, to facilitate insertion of the catheter assembly **12** into a vein or artery of a patient, the bevel **220** that defines at least in part the distal tip **24** to be sharp is generally placed in a face-up position, as illustrated in FIG. 1. In some instances, clinicians may find it difficult to orient the bevel **220** in the face-up position by visual inspection of the distal portion of the needle cannula **22**. To avoid such a difficulty, the needle hub **20** may be provided with an indicator that indicates the orientation of the bevel **220** relative to the needle hub **20**. In one embodiment, for example, the indicator may include a flat **242** formed on the intermediate flange **192** of the needle hub **20** that is generally axially aligned with the bevel **220** in needle cannula **22**. In this way, a clinician only has to identify the flat **242** on the needle hub **20** to know the orientation of the bevel **220**. It should be recognized that other indicia, including various numbers, letters, symbols, etc., may be provided as an indicator, and the invention is not limited to the flat **242** shown and described herein.

With the catheter assembly **12** and needle assembly **14** assembled, the tip protector **30** may be assembled. To this end, the inner and outer members **32**, **34** may be formed separately and in a manner as described more fully above. Additionally, the stop washer **102** may be coupled to the inner member **32** in a manner as described above. Next, the inner member **32** may be loaded into the outer member **34** by inserting the proximal end **38** of the inner member **32** into the passageway **124** of the outer member **34** via its distal end **122**. In one aspect, the inner and outer members **32**, **34** may be oriented during this loading process. In that regard, the inner and outer members **32**, **34** may be oriented such that the cutouts **142**, indentations **150** and flexible tabs **158** of the outer member **34** generally axially align with the raised

bosses **74** and grooves **78** formed on the inner member **32**. Such an orientation also provides that the flexible tabs **130** axially align with the grooves **62** formed in the arms **48a**, **48b** of inner member **32**. Such orienting of the inner and outer members **32**, **34** is generally shown in FIG. 1.

The inner member **32** may be inserted into the outer member **34** until the proximal end **38** thereof is adjacent, but spaced from, the proximal end **120** of the outer member **34**. In this regard, the inner member **32** may be partially seated within the outer member **34** and subsequently fully seated within the outer member **34**. For example, in an automated assembly, it may be desirable to define a pre-assembly position wherein the inner member **32** is partially seated within the outer member **34** (e.g., during movement of the pre-assembled tip protector along the assembly line) and fully seated within the outer member in a separate assembly step. Alternatively, the inner member **32** may be fully seated within the outer member **34** without having a pre-assembly position. In any event, in this embodiment, the inner member **32** is configured to be substantially completely within the outer member **34**. As noted below in an alternative embodiment, the invention is not so limited.

With the tip protector **30** assembled, the tip protector **30** may be threaded onto the needle cannula **22** by inserting the distal tip **24** thereof into the proximal end of tip protector **30** and more particularly through the proximal openings **184**, **116** of the outer and inner members **34**, **32**, respectively. The various flexible parts of the inner and outer members **32**, **34** (e.g., arms **48a**, **48b**, flexible tabs **130**, etc.) are not being unduly constrained, such as by the outer member **34** or catheter hub **16**, and therefore tip protector **30** may accommodate the insertion of the needle cannula **22** therethrough. The tip protector **30** is located on needle shaft **23** generally spaced from the distal tip **24** thereof so as to provide sufficient space for the formation of the engagement feature, such as protuberance **222**. To this end, the protuberance **222** may be formed by a pressing method or other suitable methods as described above.

The catheter assembly **12** may then be loaded onto the needle assembly **14** such that the tip protector **30** is substantially positioned within the catheter hub **16**, and the needle hub **20** is in proximity to the proximal end **230** thereof. In that regard, the interaction between the flexible tabs **130** and retention groove **240** may provide a snap-fit feature as the tip protector **30** is inserted into the catheter hub **16**. The assembly is then loaded into the sheath **28** via its proximal opening **216** and secured together in the manner described above. The safety catheter **10** may then be further processed and appropriately packaged in a manner generally known in the art. In one embodiment and as noted above, the assembly process described above may be an automated type of process. The invention is not so limited, however, as manual or hybrid types of processes may be used for assembly of the safety catheter **10**.

FIG. 2 illustrates the catheter device **10** in a ready position wherein the bevel **220** and distal tip **24** of the needle cannula **22** extend beyond the distal end **26** of the catheter tube **18**, and the safety catheter **10** is ready for insertion into the vasculature of a patient. The interaction of the various components of safety catheter **10** when in the ready position will now be described in reference to FIGS. **16A** and **16B**. When in the ready position, a substantial portion of tip protector **30** is positioned within the catheter hub **16**. In that regard, the tip protector **30** is inserted into the catheter hub **16** during assembly until the distal facing lip **174** of flange **172** engages the chamfer **234** adjacent the proximal end **230** of the catheter

15

hub 16. This engagement prevents the tip protector 30 from moving any further distally within the catheter hub 16. In one embodiment, no portion of the tip protector 30, and more particularly, no portion of outer member 34 thereof engages the proximal end 230 of catheter hub 16. In alternative 5 embodiments, however, the tip protector 30 may additionally or alternatively engage the proximal end 230 of catheter hub 16 (not shown). As shown in these figures, a portion of flange 172 and extension portion 178 may project beyond the proximal end 230 of catheter hub 16. The length l_1 of the tip 10 protector 30 that extends proximal of the proximal end 230 is sufficiently small such that gripping and manipulating the tip protector 30 with the human hand would be, for all intents and purposes, impractical if not impossible using this portion. That portion of the outer member 34 that projects out of the catheter hub 16 is covered by the spines 194 and therefore 15 could not be grasped in any event.

The tip protector 30 may be releasably secured within the catheter hub 16 through an interaction between the outer member 34 and the inner wall 244 of the catheter hub 16. 20 More particularly, and as best illustrated in FIG. 16A, when in the ready position, the distal end 136 of flexible tabs 130 is positioned adjacent retention groove 240 such that the abutment surface 138 thereof is positioned within the retention groove 240. In one embodiment, the flexible tabs 130 may be 25 configured to be biased generally inward relative to central axis 126 such that, in their natural or unbiased state (and without the inner member 32 being positioned within outer member 34), the flexible tabs 130 would extend within the passageway 124 of outer member 34.

However, due to the presence of the inner member 32 within the outer member 34, the flexible tabs 130 extend generally outward of the cylinder of the outer member 34 and against their bias when the tip protector 30 is inserted into the catheter hub 16 and in the ready position. In one embodiment, 35 the flexible tabs 130 may be configured such that the abutment surface 138 makes contact with the inner wall 244 of the catheter hub 16 when in the ready position. Alternatively, however, the flexible tabs 130 may be configured such that the abutment surface 138 is positioned in the retention groove 240, but spaced from the inner wall 244 of the catheter hub 16. In such an embodiment, should the tip protector 30 be moved 40 proximally away from the catheter hub 16 (i.e., should the tip protector 30 be prematurely pulled out of the catheter hub 16), the abutment surface 138 would contact the wall of the retention groove 240 and restrict further proximal movement.

While in an exemplary embodiment, the flexible tabs 130 are biased generally inwardly, in an alternative embodiment, the flexible tabs 130 may be configured to be biased generally 45 outward relative to central axis 126 such that, in their natural or unbiased state, the flexible tabs 132 extend away from the passageway 124 of outer member 34. In this embodiment, the flexible tabs 130 may be configured such that the abutment surface 138 makes contact with the inner wall 244 of the catheter hub 16 when in the ready position. Alternatively, 50 however, the flexible tabs 130 may be configured such that the abutment surface 138 is positioned in the retention groove 240, but spaced from the inner wall 244 of the catheter hub 16 when in the ready position. In either embodiment, such a positioning relative to the retention groove 240 is independent of the position of the inner member 32. 60

In reference to the exemplary embodiment, although the flexible tabs 130 are capable of moving out of retention groove 240 (e.g., under their own bias), at least when in the ready position, it should be realized that the flexible tabs 130 65 are impeded from moving generally radially inward (and away from retention groove 240) by the presence of a portion

16

of the inner member 32, which is in its first position relative to outer member 34 in the ready position of catheter device 10. In that regard, as shown in FIG. 16A, when in the ready position, an inner surface 246 of the flexible tabs 130 may be 5 in close proximity to the bottom wall 64 of grooves 62. For example, in one embodiment, the inner surface 246 of flexible tabs 130 may be configured to engage the bottom wall 64, while in an alternative embodiment, the inner surface 246 of flexible tabs 130 may be slightly spaced from the bottom wall 64. As can be appreciated, in such an alternative embodiment, the slight spacing cannot be so great as to allow the flexible 10 tabs 130 to move out of the retention groove 240 without being impeded by the inner member 32. In the various embodiments, attempts to pull the tip protector 30 out of the catheter hub 16 would require the flexible tabs 130 to move radially inward to an extent that allows them to come away from retention groove 240. Such radially inward movement, however, is impeded due to the presence of the inner member 32 and the tip protector 30 remains secured to the catheter hub 16. 15

As further illustrated in FIGS. 16A and 16B, when in the ready position, the inner member 32 is in its first position relative to outer member 34 and is entirely positioned within the outer member 34. In one embodiment, the arms 48a, 48b 20 may be configured to be biased generally radially outward relative to central axis 44. For example, the outer member 34 may be configured to constrain the arms 48a, 48b (i.e., but for the outer member 34, the arms 48a, 48b would move further apart from one another). When in the ready position, the inner surface 54 of the arms 48a, 48b may be in proximity to an outer surface 248 of the needle shaft 23. For example, in one embodiment, the inner surface 54 of the arms 48a, 48b may be 25 configured to engage the outer surface 248 of the needle shaft 23. In an alternative embodiment, however, the inner surface 54 of arms 48a, 48b may be slightly spaced from the outer surface 248 of the needle shaft 23. This may, for example, provide for a reduced drag force on the needle cannula 22 as it is being pulled proximally during use. 30

While in one embodiment, the arms 48a, 48b are biased generally radially outward, in an alternative embodiment, the arms 48a, 48b may be configured to be biased generally 35 radially inward relative to central axis 44. In such an embodiment, the inner surface 54 of arms 48a, 48b may be configured to engage the outer surface 248 of the needle shaft 23 and may be moved generally radially outward due to the presence of the needle cannula 22 extending through inner member 32 (e.g., the needle cannula 22 moves the arms 48a, 48b radially outward against the bias). 40

Additionally, the locking tabs 158 of the outer member 34 may be biased generally inward relative to central axis 126. 45 More particularly, when in the ready position, and the inner member 32 is in its first position relative to outer member 34, the locking tabs 158 may be configured to engage the bottom wall 80 of groove 78. This engagement may serve a couple of purposes including, for example, providing a resistance force to movement of the inner member 32 relative to the outer member 34 during the initial proximal movement of the needle cannula 22 as it is being withdrawn. The engagement 50 between the locking tabs 158 and groove 78 may further provide an anti-rotation feature between the inner and outer members 32, 34. 55

As discussed above, the inner and outer members 32, 34 are orientated in a specific manner during assembly so as to provide proper operation of the tip protector 30. Accordingly, 60 it would be undesirable to have relative rotation therebetween during use of the safety catheter 10. For example, it would be undesirable to allow the inner member 32 to rotate relative to

outer member 34 with rotation of the needle cannula 22. In that regard, the tip protector 30 may be designed to permit rotation of the needle cannula 22 without causing rotation of the tip protector 30 (i.e., the needle cannula 22 is free to rotate relative to the tip protector 30). Additionally, even if, through friction forces, rotation of the needle cannula 22 would tend to rotate the inner member 32 (or the outer member 34), relative rotation between the inner and outer members 32, 34 is restricted by the interaction of several features. For example, as noted above, engagement of the locking tabs 158 with grooves 78 provides a restriction to relative rotation between the inner and outer members 32, 34. More particularly, if relative rotation between the inner and outer members 32, 34 were initiated, the side edges of the flexible tabs 158 would contact the side walls 82 of grooves 78 and therefore resist the relative rotation.

Additionally, as shown in FIG. 16B, when in the ready position, the raised bosses 74 on the inner member 32 may be received within the cutouts 142 in the outer member 34 such that, for example, the outer surface of the raised bosses 74 is substantially flush with the outer surface of the outer member 34. The invention is not so limited as the raised bosses 74 may extend beyond the periphery of the outer member 34 in alternative embodiments. In any event, if relative rotation between the inner and outer members 32, 34 were initiated, the side abutment surfaces 76 of raised bosses 74 would contact the side edges 148 of cutouts 142 and therefore resist the relative rotation.

In addition to preventing relative rotation between the inner and outer members 32, 34, the raised bosses 74 and cutouts 142 may also resist axial movement of the inner member 32 relative to the outer member 34 in at least one direction. More particularly, the distal abutment surface 76 on raised bosses 74 and distal edge 146 of cutout 142 provide a positive stop that prevents the inner member 32 from axially shifting distally relative to the outer member 34 when in the ready position.

In addition to the above, the safety catheter 10 may be designed to allow the tip protector 30 to rotate relative to the catheter hub 16. However, rotation of the tip protector 30 relative to the catheter hub 16 would similarly not cause relative rotation between the inner and outer members 32, 34 due to the interaction between the features described above. Thus, in accordance with embodiments of the invention, the needle cannula 22 is free to rotate relative to the tip protector 30 and the tip protector 30, is free to rotate relative to the catheter hub 16.

As further shown in FIGS. 16A and 16B, when in the ready position, the spines 194 on needle hub 20 may be disposed about the flange 172 and extension portion 178 that extend beyond the proximal end 230 of the catheter hub 16. Additionally, in one embodiment, the end face 200 of the spines 194 may be configured to engage the proximal end 230 of the catheter hub 16. Moreover, when in the ready position, the needle hub 20 may be configured to engage or alternatively be spaced from the tip protector 30. By way of example, in one embodiment, the inner surface 198 of the spines 194 may engage the outer surface 250 of extension portion 178. Additionally, or alternatively, the taper 202 adjacent the distal end of spines 194 may engage the proximally facing lip 176 of flange 172. Furthermore, the end of distal nose 188 may additionally or alternatively engage the end face 180 of outer member 34.

After the safety catheter 10 is inserted into the artery or vein of the patient, the needle hub 20, and thus the needle cannula 22, may be moved proximally relative to the catheter assembly 12 and tip protector 30. However, the safety cath-

eter 10 is configured such that drag forces imposed on the tip protector 30 due to the proximal movement of the needle cannula 22 are not sufficient to overcome the forces retaining the tip protector 30 to the catheter hub 16. Accordingly, the tip protector 30 remains secured to the catheter hub 16 during at least the initial proximal movement of the needle cannula 22.

Additionally, the drag forces imposed on the inner member 32 of tip protector 30 due to the proximal movement of the needle cannula 22 are not sufficient to axially shift the inner member 32 relative to the outer member 34. In this regard, the engagement between locking tabs 158 and the bottom wall 80 of grooves 78, the engagement between the flexible tabs 130 and the bottom wall 64 of grooves 62, the resistance to movement of the inner member 32 relative to the outer member 34 due to the generally outwardly biasing of the arms 48a, 48b (e.g., engagement between the raised bosses 74 on arms 48a, 48b and the proximal edge 144 of cutout 142), or other sources, provides a resistive force that is greater than the drag forces imposed on the inner member 32 due to proximal movement of the needle cannula 22. Accordingly, the inner member 32 does not move proximally relative to the outer member 34 during at least this initial proximal movement of the needle cannula 22.

As the needle hub 20 and needle cannula 22 are moved further in the proximal direction, the distal tip 24 thereof moves proximal of the distal end 122 of the outer member 34 and proximal of the distal end 40 of the inner member 32, which is disposed within the outer member 34. Such a positioning of distal tip 24 relative to inner member 32 and outer member 34 is best illustrated in FIGS. 17A and 17B. Note that although the needle cannula 22 no longer blocks the arms 48a, 48b, the arms 48a, 48b do not move radially inward (due to their outward bias). Thus, at this point, the raised bosses 74 of the inner member 32 remain in the cutouts 142 of the outer member 34. If the arms 48a, 48b were biased generally radially inward toward central axis 44, as in one of the alternative embodiments discussed above, positioning the distal tip 24 within the inner member 32 as shown in these figures would allow the arms 48a, 48b to close radially inward under their own bias due to the absence of the needle cannula 22 between the distal portion of the arms 48a, 48b. However, in such an alternative embodiment, the closing down of the arms 48a, 48b radially inward would not otherwise affect the release of the tip protector 30 from the catheter hub 16 or affect the lack of axially movement of the inner member 32 within the outer member 34.

With reference to FIGS. 17A and 17B, as the needle hub 20 and needle cannula 22 are moved further in the proximal direction, and with the distal tip 24 positioned within the inner member 32 so as to not block the radially inward movement of the arms 48a, 48b, the protuberance 222 is configured to engage the stop washer 102. In this regard, the portion of the needle shaft 23 proximal of protuberance 222 is sized so as to pass through the central aperture 110 in stop washer 102, pass through the opening 116 in the proximal end face 114 of inner member 32, and pass through the opening 182 in the proximal end face 180 of outer member 34. A cross dimension of protuberance 222, however, is sized to be greater than the cross dimension of the central aperture 110 in stop washer 102. Thus, when the protuberance 222 engages the stop washer 102, further proximal movement of the needle cannula 22 relative to the inner member 32 is thereby restricted.

Accordingly, with further proximal movement of the needle hub 20 and needle cannula 22, the engagement between the protuberance 222 and stop washer 102, which is secured within the inner member 32 as described above, causes the inner member 32 to be axially shifted proximally

relative to the outer member 34. As the inner member 32 is pulled further proximally within the outer member 34, the inner surface 246 of the flexible tabs 130 remains in close proximity to (e.g., engage or be slightly spaced from) the bottom wall 64 of grooves 62. In this way, for example, even as the inner member 32 is initially axially shifted relative to the outer member 34, the presence of the inner member 32 still impedes the flexible tabs 130 from moving generally inward so as to come away from retention groove 240. Accordingly, during at least the initial axial shifting of the inner member 32 relative to the outer member 34, the outer member 34, and thus the tip protector 30, remains secured to the catheter hub 16.

In addition to the above, during at least this initial axial shifting of the inner member 32 relative to the outer member 34, an inner surface 252 of flexible tabs 158 engages and slides along the bottom wall 80 of groove 78. Additionally, during the axial shifting of the inner member 32 within the outer member 34, the cammed proximal surface of the raised bosses 74 engage the proximal edge 144 of cutouts 142 and causes the arms 48a, 48b to move generally radially inward so as to essentially close down against their bias such that the raised bosses 74 are no longer received in the cutouts 142, but are within the confines of the outer member 34 proximal of cutouts 142. Moreover, the raised bosses 74 and the indentations 150 are generally axially aligned such that the axial shifting of the inner member 32 away from its first position causes the raised bosses 74 to contact the engaging surfaces 152 of the indentations 150, which project into the passageway 124 of the outer member 34. This engagement, in turn, causes the arms 48a, 48b to close down (i.e., move radially inward toward each other) even further.

Regardless of the particular embodiment, it should be recognized that the drag forces imposed on the outer member 34 by axial shifting of the inner member 32 is less than the retentive force imposed between the outer member 34 and the catheter hub 16, such as via the retentive force imposed between the flexible tabs 130 and the retention groove 240 and the inability of the flexible tabs 130 to move away from the retention groove 240 due to the presence of the inner member 32 relative thereto. This relationship in the various forces allows the inner member 32 to be axially shifted relative to the outer member 34 without the outer member 34, and thus the tip protector 30, from being prematurely pulled proximally out of the catheter hub 16.

With reference to FIGS. 18A and 18B, as the inner member 32 continues to be axially shifted proximally within the outer member 34, the proximal tab portion 164 of locking tabs 158 drops into cavity 84 formed in the bottom wall 80 of groove 78 (FIG. 18B) due to the generally inward bias of locking tabs 158. When the proximal tab portion 164 drops into cavity 84, distal axial shifting of the inner member 32 relative to the outer member 34 is restricted by engagement between the contacting edge 170 of locking tabs 158 and the first end wall 86 of cavity 84 (i.e., the inner member 32 cannot be pushed out of the outer member 34). Furthermore, when the proximal tab portion 164 drops into cavity 84, the proximal end 38 of the inner member 32 may be in close proximity to the proximal end 120 of the outer member 34. In this regard, the opening 182 in the proximal end 120 of outer member 34 is sized so as to prevent the inner member 32 from passing therethrough.

Thus, the proximal end 120 of outer member 34 operates as a stop that prevents further proximal axial shifting of the inner member 32 relative to the outer member 34. In this way, when the proximal tab portion 164 drops into cavity 84, proximal and distal axial shifting of the inner member 32 relative to the

outer member 34 is substantially restricted and the inner and outer members 32, 34 are essentially locked together. In that regard, the locking tabs 158 and cavity 84 operate as a locking mechanism that restricts axial shifting of the inner member 32 relative to the outer member 34 in the distal direction. Similarly, the sizing of opening 182 in the proximal end 120 of outer member 34, so as to block passage of inner member 32 therethrough, may also operate as a locking mechanism to restrict proximal axial shifting of the inner member 32 relative to the outer member 34.

In one embodiment, the outside surface of proximal end face 114 of inner member 32 may engage the inside surface of proximal end face 180 of outer member 34 at nearly the same time that the proximal tab portion 164 drops into cavity 84, such that there is essentially no play between the inner and outer members 32, 34 when the proximal tab portion 164 drops into cavity 84. In an alternative embodiment, however, and as illustrated in FIGS. 18A and 18B, the proximal end 38 of the inner member 32 may be slightly spaced from the proximal end 120 of the outer member 34 when the distal tab portion 164 drops into cavity 84. In such an embodiment, additional proximal axial shifting of the inner member 32 relative to the outer member 34 may be permitted before the proximal ends 38, 120 of the inner and outer members 32, 34, respectively, engage each other. In other words, although the inner and outer members 32, 34 are essentially locked together, a certain amount of play may exist between the two members 32, 34 after being locked together. In any event, the inner member 32 is positioned so as to shield the distal tip 24 of needle cannula 22.

After the proximal tab portion 164 drops into the cavity 84 (in which the proximal ends 38, 120 of the inner and outer members 32, 34 may or may not engage as explained above), the inner member 32 is in a second position relative to the outer member 34 wherein the inner member 32 no longer blocks the movement of the flexible tabs 130 radially inward due to their bias. Accordingly, when the inner member 32 is in the second position, the flexible tabs 130 are permitted to move radially inward and away from the retention groove 240 so as to release the tip protector 30 from the catheter hub 16. Although the positioning of the inner member 32 so as to no longer block the flexible tabs 130 of the outer member 34 occurs after the proximal tab portion 164 drops into the cavity 84, such positioning does not necessarily occur simultaneously.

In that regard, in one embodiment, indeed, the inner member 32 may be positioned so as to no longer block the movement of the flexible tabs 130 of the outer member 34 at substantially the same time that the proximal tab portions 164 drop into the cavity 84. In an alternative embodiment, however, the proximal tab portions 164 may drop into the cavity 84, but the inner member 32 may have an intermediate position in which it is still positioned so as to block the movement of the flexible tabs 130 away from the retention groove 240 and impede release of the tip protector 30 from the catheter hub 16. It is only with further proximal axial shifting of the inner member 32 relative to the outer member 34, and before or simultaneous with the proximal end face 114 of inner member 32 engaging the proximal end face 180 of outer member 34, that the inner member 32 is in the second position and no longer blocks the movement of the flexible tabs 130 such that the tip protector 30 may be removed from the catheter hub 16.

When the inner member 32 no longer blocks the movement of the flexible tabs 130, the tabs 130 move radially inward under their own bias and away from the retention groove 240. In one embodiment, the abutment surface 138 of the flexible

tabs 130 may be completely removed from the retention groove 240 such that there is no tug force required to remove the tip protector 30 from the catheter hub 16 (e.g., passive release). In this embodiment, the flexible tabs 130 may move radially inward such that at least a portion of the tabs 130 drop in front of the inner member 32. More particularly, the contacting edge 140 of the tabs 130 may engage or confront (e.g., be slightly spaced from) the distal end face 72 of the inner member 32, when the inner member 32 no longer blocks the tabs 130.

In an alternative embodiment, the flexible tabs 130 may move radially inward under their own bias when no longer blocked by the inner member 32, but by an amount that does not completely remove the abutment surface 138 from the retention groove 240. In this embodiment, when the tip protector 30 is removed from the catheter hub 16, the abutment surface 138 will slightly contact the retention groove 240 causing the flexible tabs 130 to move slightly radially inward and out of the retention groove 240. This will result in a relatively small tug force in order to remove the tip protector 30 from the catheter hub 16.

While the operation has been described above for the flexible tabs 130 being biased generally radially inward relative to central axis 126, one of ordinary skill in the art will readily understand operation of the tip protector 30 when the flexible tabs 130 are biased generally radially outward relative to central axis 126. In this regard, one of the primary differences is that when the inner member 32 is in its second position and no longer blocking the movement of the tabs 130, the tabs 130 will not move radially inward under a biasing force and away from the retention groove 240 (as was the case above). Instead, the abutment surface 138 will remain engaged or nearly engaged with the retention groove 240. Similar to the above, in this embodiment, when the tip protector 30 is removed from the catheter hub 16, the abutment surface 138 will contact the retention groove 240 causing the flexible tabs 130 to move radially inward and out of the retention groove 240 (e.g., duckbill type). As the flexible tabs 130 are more fully positioned relative to the retention groove 240, a larger tug force may be required in order to remove the tip protector 30 from the catheter hub 16 (e.g., active release). In some applications, such a tug force may be undesirable in which case the embodiment having radially inward biased flexible tabs 130 may be employed.

FIG. 19 illustrates the needle assembly 14 fully withdrawn from the catheter assembly 12 (not shown), which remains in fluid communication with the vasculature of the patient. As shown, the distal portion of the needle cannula 22, including the distal tip 24 thereof, is shielded by tip protector 30 while more proximal portions of the needle shaft 23 are exposed. Furthermore, the tip protector 30 is designed to prevent or significantly reduce the chance or likelihood of re-exposing the distal tip 24 of the needle cannula 22. As discussed above, once the locking tabs 158 drop into cavity 80, the inner and outer members 32, 34 are essentially locked together and tip protector 30 is also essentially locked onto needle cannula 22. In that regard, should the needle cannula 22 be pulled proximally relative to the tip protector 30 (e.g., such as by grabbing the outer member 34 thereof with one hand and pulling proximally on the needle hub 20 with the outer hand), the protuberance 222 will act on stop washer 102, which in turn acts on inner member 32. However, as noted above, the proximal end 38 of inner member 32 is engaged with or is in near engagement with the proximal end 120 of outer member 34 so as to effectively prevent the needle cannula 22 from being pulled proximally out of the tip protector 30.

Similarly, should the needle cannula 22 be pushed distally relative to the tip protector 30 (e.g., such as by grabbing the outer member 34 thereof with one hand and pushing distally on the needle hub 20 with the outer hand), there may be some slight distal movement of the needle cannula 22 relative to tip protector 30. However, with reference to FIGS. 18A and 18B, as the needle cannula 22 moves distally, the needle cannula 22 will contact the inner surface 54 of arms 48a, 48b. More particularly, when the inner member 32 is in its second position relative to the outer member 34, the cross dimension of passageway 42 along a distal portion thereof is smaller than the cross dimension of the needle shaft 23 adjacent the distal tip 24. Accordingly, when in the second position, the passageway 42 along distal tapered bore portions 92 is sized so as to block the path of needle cannula 22 (i.e., the size of the distal tapered bore is smaller than the needle cannula 22). Additionally, when in the second position, the arms 48a, 48b of inner member 32 are constrained by the outer member 34 (e.g., engagement between the engaging surfaces 152 of indentations 150 and the raised bosses 74), and thus, the arms 48a, 48b are not capable of flexing generally radially outward so as to increase the size of passageway 42 and allowing the needle cannula 22 to pass therethrough.

Furthermore, when distal movement of the needle cannula 22 relative to the inner member 32 has been blocked, depending on the particular embodiment, it may be possible to axially shift the inner member 32 distally relative to the outer member 34. For example, if there is some slight play between the inner and outer members 32, 34 when they are essentially locked together, such relative axial shifting therebetween may be possible. However, any such relative axial shifting is small and distal movement of the inner member 32 relative to the outer member 34 is eventually restricted by engagement of the contacting edge 170 of locking tabs 158 and the first end wall 86 of cavity 84. Accordingly, even though there may be slight relative movement between the needle cannula 22 and tip protector 30, ultimately the distal tip 24 of the needle cannula 22 is effectively prevented from re-emerging by pushing the needle cannula 22 distally out of the tip protector 30.

In various alternative embodiments, the inner member may include additional features to restrict re-emergence of the needle cannula 22 by pushing the needle cannula 22 distally out of the tip protector 30. By way of example, when the cross dimension of the needle shaft 23 becomes relatively small (e.g., 20, 22, and 24 gauge cannulas), the needle cannula 22 may be more susceptible to undesirable flexing and a possible side-out failure mode. Accordingly, for these larger gauges, it may be desirable to include features that limit or restrict the amount of flexing of the needle cannula 22 during, for example, a potential side-out failure mode or other accidental or extreme conditions. To this end and as illustrated in FIG. 20, the inner member 32' may include sidebites. More particularly, the sidebites may include one or more projections 260 on the inner surface 54 of at least one the arms 48a, 48b that limit the flexing of the needle cannula 22. In an exemplary embodiment, at least one of the arms 48a, 48b includes a projection 260 disposed on opposed sides of the tapered bore portion 92, such as along slot faces 58, which are increased due to the smaller size of tapered bore portion 92. These projections 260 essentially block excessive flexing of the needle cannula 22 in a direction toward the opposed slots 46. In one embodiment, the sidebites may be integrally formed in the inner member 32' such as, for example, during molding of the inner member 32'.

In order to allow the arms 48a, 48b of the inner member 32' to move to a fully closed position (such as when in the second

position), the arms **48a**, **48b**, which opposes the projections **260** may include a corresponding notch **262** configured to receive at least a portion of the projections **260** therein. In an exemplary embodiment, these may also be formed during molding of the inner member **32'**. In this way, the operation of the tip protector **30** is not adversely effected while providing an additional feature for restricting re-emergence of the needle cannula **22** in a potential failure mode or extreme condition. In any event, should the needle cannula **22** be forced distally relative to the tip protector **30** and the needle cannula **22** start bending or flexing in a direction toward the opposed slots **46**, the needle cannula **22** will contact the projections **260** and be prevented from any further flexing in those directions. Of course, any flexing or bending of the needle cannula **22** in directions other than toward the opposed slots **46** would be restricted by engagement with the solid inner surface **54** arms **48a**, **48b** themselves.

In addition to, or in lieu of, the projections **260** and corresponding notches **262** described above, various embodiments in accordance with the invention may include an inner member **32"** having further features to restrict re-emergence of the needle cannula **22** by pushing the needle cannula **22** distally out of the tip protector **30**. Again, such additional features may be desirable for the larger gauge (smaller cross dimensions) needle cannula **22**. To this end, and as shown in FIG. **21**, the inner surface **54** of at least one of the arms **48a**, **48b** may include one or more ribs **264** adjacent the distal end **40** of the arms **48a**, **48b** configured to further block the path of the needle cannula **22**. For example, in one embodiment, the ribs **264** may completely close off the re-emergence path of the needle cannula **22** from the tip protector **30**. The invention, however, is not limited to completely closing off the path. Similar to above, in an exemplary embodiment, ribs **264** may be formed in inner member **32"** during, for example, molding thereof.

In one exemplary embodiment, one rib **264a** may be located on one of the arms **48a**, **48b** and two adjacent ribs **264b**, **264c** may be located on the other of the arms **48a**, **48b**. When the arms **48a**, **48b**, close down in front of the distal needle tip **24**, the ribs **264a-c** may be configured to engage each other. For example, the one rib **264a** may be configured to nest between the two adjacent ribs **264b**, **264c** when the inner member **32"** is at least in the second position. In this way, should there be an attempt to move the needle cannula **22** distally relative to the tip protector **30** (either intentionally or accidentally), the tip **24** thereof would come into contact with the ribs **264** and be prevented from moving any further distally relative to the tip protector **30**.

Those of ordinary skill in the art will recognize that the arrangement of ribs **264** is not limited to the particular arrangement shown and described herein, but encompasses a broad range of rib configurations designed to drop down in front of the distal needle tip **24** and block the re-emergence path of the needle cannula **22**. It should also be recognized that the ribs **264** may be configured such that the ribs **264** do not engage the needle cannula **22** when in the ready position. In alternative embodiments, however, it should be recognized that the ribs **264** may engage and slide along the outer surface **248** of the needle cannula **22** during use.

In the various embodiments described above, the inner member **32** remained within the outer member **34** in both the first position (e.g., the ready state of the safety catheter **10**) and the second position (e.g., the protected state of the safety catheter **10**). While this may provide certain advantages to enhancing the strength of the tip protector **30** or enhancing the shielding of the distal tip **24** of the needle cannula **22**, the invention is not so limited. In this regard, FIGS. **22A-23B** in

which like reference numbers refer to like features in FIGS. **1-19**, but succeeded by the letter a, illustrate an embodiment wherein the tip protector **30a** includes an inner member **32a** that projects out of the outer member **34a** when in the first position. In this embodiment, the outer member **34a** may be shorter in length as compared to outer member **34**, for example, truncating near the distal end of flexible tabs **130a**, such that the inner member **32a** projects distally of the outer member **34a** in the ready position. Tip protector **30a** operates on similar principles as that described above. More particularly, those of ordinary skill in the art will appreciate that the interaction between the needle cannula **22a** and the inner member **32a** (e.g., stop washer **102a**), the interaction between the inner member **32a** and the outer member **34a**, and the interaction between outer member **34a** and catheter hub **16a** remains substantially similar. FIGS. **23A** and **23B** show the tip protector **30a** when in the protected position. In this position, the inner member **32a** is substantially within the outer member **34a** and the tip protector **30a** is sufficiently secured to the needle cannula **22a** to shield the distal tip **24a** thereof.

FIG. **24** in which like reference numbers refer to like features in FIGS. **1-19**, but succeeded by the letter c illustrates a further alternative embodiment of a safety catheter **10c** that is similar to the safety catheter **10** and includes a tip protector according to various embodiment as previously described above. As will be noted from the figure, the catheter assembly **12c** includes a pair of wings **270** coupled to the catheter hub **16c** on one side thereof in a conventional manner (e.g., patient side). As is generally known in the art, the wings **270** may be used to secure the catheter assembly **12c** to the patient after being inserted therein using tape, for example.

As illustrated by FIG. **25**, the tip protector as described above may also be incorporated in a side port catheter design. In this regard, FIG. **25** in which like reference numbers refer to like features in FIGS. **1-19**, but succeeded by the letter d, includes a safety catheter **10d** that is similar to the safety catheter **10**. The catheter assembly **12d** includes a side port **280** formed therewith having a cover **282** selectively removable from the side port **280** for gaining access to the interior chamber **204d** of the catheter hub **16d**. As the construction and operation of a side port catheter is generally well understood in the art, a more complete description thereof will be omitted herein. As further shown in FIG. **25**, in addition to the side port **280**, the catheter assembly may also include a pair of wings **284** coupled to the catheter hub **16d**. As shown, the needle hub **20d** of catheter assembly **10d** may have a slightly different design. In this regard, the body member **186d** of the needle hub **20d** may have a proximal portion **286** and a distal portion **288** being sized larger than the proximal portion **286** and configured so as to fit over the proximal end **230d** of the catheter hub **16d**. The needle hub **20d** may also include a generally radially projecting tab **290** that facilitates use of the safety catheter **10d** during, for example, insertion of the catheter assembly **12d** into the vasculature of a patient.

The sheath **28d** used with catheter insertion device **10d** may also differ from sheath **28** described above. In this regard, the sheath **28d** may include a straw-like tubular member **292** configured to shield the catheter tube **18d** and needle cannula **22d** during transit or storage of the catheter insertion device **10d**. The proximal end **294** of the tubular member **292** may be configured to secure to the distal end **296** of the needle hub **20d** through, for example, a friction fit. As illustrated in FIG. **25**, the sheath **28d** may include a plug **298** coupled to a distal end **300** of the tubular member **292**. In use, the sheath **28d** is removed from the catheter device **28d** and the catheter assembly **12d** is inserted into the patient as described above. After insertion, the plug **298** of sheath **28d** may be secured to

the proximal end **230d** of the catheter hub **16d**. The plug **298** effectively closes off the proximal end **230d** of the catheter hub **16d** such that communication between an external device and the vasculature of the patient is via the side port **280**, as is generally understood in the art. Of course, instead of the plug **298** on sheath **28d** being used in this capacity, other conventional methods may be used to close off the proximal end **230d** of catheter hub **16d**. In that case, the plug **298** on sheath **28d** may be omitted.

While the present invention has been illustrated by the description of embodiments thereof, and while the embodiments have been described in considerable detail, it is not intended to restrict or in any way limit the scope of the appended claims to such detail. Additional advantages and modifications will readily appear to those skilled in the art.

For example, as discussed above, the interaction between the needle cannula and the inner member to cause movement of the inner member within the outer member includes the protuberance on needle cannula and the stop washer captured within the inner member. Other arrangements, however, are possible. For example, instead of having an outwardly projecting feature (e.g., protuberance **222**) on the needle cannula, an inwardly projecting feature, such as an inwardly projecting cavity or groove may also be used (not shown). In this embodiment, the stop member associated with the inner member may be configured to drop into the cavity or groove to provide a positive lock between the inner member and the needle cannula. Similar to the above, the inner and outer members may be effectively locked together when the inner member is in the second position to limit relative movement therebetween. Thus, a flexible tab/cavity arrangement may be used to limit distal movement of the inner member relative to the outer member. Additionally, an opening in the proximal end of the outer member may be sized to restrict the passing of the inner member therethrough. It should be realized that because there is a positive lock between the inner member and the needle cannula in such an embodiment, the inner member may no longer need to block the path of the needle cannula when in the second position.

In addition to the above, depending on the specific application, the inner and outer members may be structurally enhanced so as to accommodate the stresses and strains imposed thereon during use. Accordingly, various ribbing, ridges, etc., may be selectively used to add strength in desired areas. By way of example, the outer member may include a containment ring (not shown) on its outer surface to increase the hoop strength of the outer member. The containment ring may be a separate element which is coupled to the outer member or be integrally formed, via material buildup in the desired area, with the outer member. In one embodiment, for example, a containment ring may be disposed adjacent the proximal end of slots, but configured not to interfere with the operation of the flexible tabs or indentations.

Thus, the invention in its broader aspects is, therefore, not limited to the specific details, representative apparatus and method, and illustrative examples shown and described. Accordingly, departures may be made from such details without departing from the spirit or scope of the general inventive concept.

Having described the invention, what is claimed is:

1. A safety catheter, comprising:

a catheter hub and a catheter tube extending distally thereof;

a needle hub and a needle cannula extending distally thereof, the needle cannula having a distal tip; and

a tip protector for shielding the distal tip, comprising an outer member including a flexible tab extending radially

outward of the outer member configured to releasably engage with the interior of the catheter hub and to release therefrom on radially inward movement of the tab, and an inner member being axially received entirely within the outer member and having a portion to impede radially inward movement of the flexible tab when the inner member portion is disposed axially adjacent the flexible tab, the needle cannula being received in the inner and outer members, the inner member configured to be axially shiftable relative to the outer member between a first position wherein the distal tip extends distally of the tip protector and the inner member portion is disposed axially adjacent the flexible tab so as to impede release of the outer member from the catheter hub, and a second position wherein the distal tip is within the outer member and the inner member is axially shifted such that the inner member portion is no longer disposed axially adjacent the flexible tab such that inner member no longer impedes release of the outer member from the catheter hub, wherein the inner member includes a central axis and at least one arm, the arm being biased radially outward relative to the central axis.

2. The safety catheter of claim 1, wherein the outer member includes a central axis and the at least one flexible tab is biased radially inward relative to the central axis.

3. The safety catheter of claim 1, wherein the interior of the catheter hub includes a retention groove for engaging the flexible tab.

4. The safety catheter of claim 1, further comprising a locking mechanism configured to limit axial shifting of the inner member relative to the outer member when the inner member is in the second position.

5. A safety catheter, comprising:

a catheter hub and a catheter tube extending distally thereof;

a needle hub and a needle cannula extending distally thereof, the needle cannula having a distal tip;

a tip protector for shielding the distal tip, comprising an outer member including a flexible tab extending radially outward of the outer member configured to releasably engage with the interior of the catheter hub and to release therefrom on radially inward movement of the tab, and an inner member being axially received entirely within the outer member and having a portion to impede radially inward movement of the flexible tab when the inner member portion is disposed axially adjacent the flexible tab, the needle cannula being received in the inner and outer members, the inner member configured to be axially shiftable relative to the outer member between a first position wherein the distal tip extends distally of the tip protector and the inner member portion is disposed axially adjacent the flexible tab so as to impede release of the outer member from the catheter hub, and a second position wherein the distal tip is within the outer member and the inner member is axially shifted such that the inner member portion is no longer disposed axially adjacent the flexible tab such that inner member no longer impedes release of the outer member from the catheter hub; and

a locking mechanism including at least one flexible locking tab on the outer member and at least one cavity on the inner member, the locking tab engaging the cavity when the inner member is in the second position to limit axial shifting of the inner member relative to the outer member in at least one direction.

27

6. The safety catheter of claim 1, further comprising an anti-rotation mechanism configured to limit the rotation of the inner member relative to the outer member.

7. A safety catheter, comprising:

a catheter hub and a catheter tube extending distally thereof;

a needle hub and a needle cannula extending distally thereof, the needle cannula having a distal tip;

a tip protector for shielding the distal tip, comprising an outer member including a flexible tab extending radially outward of the outer member configured to releasably engage with the interior of the catheter hub and to release therefrom on radially inward movement of the tab, and an inner member being axially received entirely within the outer member and having a portion to impede radially inward movement of the flexible tab when the inner member portion is disposed axially adjacent the flexible tab, the needle cannula being received in the inner and outer members, the inner member configured to be axially shiftable relative to the outer member between a first position wherein the distal tip extends distally of the tip protector and the inner member portion is disposed axially adjacent the flexible tab so as to impede release of the outer member from the catheter hub, and a second position wherein the distal tip is within the outer member and the inner member is axially shifted such that the inner member portion is no longer disposed axially adjacent the flexible tab such that inner member no longer impedes release of the outer member from the catheter hub; and

an anti-rotation mechanism including at least one flexible locking tab on the outer member and at least one groove on the inner member, the locking tab being disposed within the groove to limit rotation of the inner member relative to the outer member.

8. A safety catheter, comprising:

a catheter hub and a catheter tube extending distally thereof;

a needle hub and a needle cannula extending distally thereof, the needle cannula having a distal tip;

a tip protector for shielding the distal tip, comprising an outer member including a flexible tab extending radially outward of the outer member configured to releasably engage with the interior of the catheter hub and to release therefrom on radially inward movement of the tab, and an inner member being axially received entirely within the outer member and having a portion to impede radially inward movement of the flexible tab when the inner member portion is disposed axially adjacent the flexible tab, the needle cannula being received in the inner and outer members, the inner member configured to be axially shiftable relative to the outer member between a first position wherein the distal tip extends distally of the tip protector and the inner member portion is disposed axially adjacent the flexible tab so as to impede release of the outer member from the catheter hub, and a second position wherein the distal tip is within the outer member and the inner member is axially shifted such that the inner member portion is no longer disposed axially adjacent the flexible tab such that inner member no longer impedes release of the outer member from the catheter hub; and

an anti-rotation mechanism including at least one cutout in the outer member and at least one raised boss on the inner member, the raised boss being disposed within the cutout to limit rotation of the inner member relative to the outer member.

28

9. The safety catheter of claim 1, further comprising a positive stop configured to limit axial shifting of the inner member relative to the outer member in at least one direction when the inner member is in the first position.

10. A safety catheter, comprising:

a catheter hub and a catheter tube extending distally thereof;

a needle hub and a needle cannula extending distally thereof, the needle cannula having a distal tip;

a tip protector for shielding the distal tip, comprising an outer member including a flexible tab extending radially outward of the outer member configured to releasably engage with the interior of the catheter hub and to release therefrom on radially inward movement of the tab, and an inner member being axially received entirely within the outer member and having a portion to impede radially inward movement of the flexible tab when the inner member portion is disposed axially adjacent the flexible tab, the needle cannula being received in the inner and outer members, the inner member configured to be axially shiftable relative to the outer member between a first position wherein the distal tip extends distally of the tip protector and the inner member portion is disposed axially adjacent the flexible tab so as to impede release of the outer member from the catheter hub, and a second position wherein the distal tip is within the outer member and the inner member is axially shifted such that the inner member portion is no longer disposed axially adjacent the flexible tab such that inner member no longer impedes release of the outer member from the catheter hub; and

a positive stop configured to limit axial shifting of the inner member relative to the outer member in at least one direction when the inner member is in the first position, wherein the positive stop includes at least one cutout in the outer member and at least one raised boss on the inner member, the raised boss being disposed within the cutout to limit axial shifting of the inner member relative to the outer member.

11. The safety catheter of claim 1, wherein the inner member is axially shifted from the first position to the second position by movement of the needle cannula.

12. The safety catheter of claim 1, wherein the needle cannula includes an engagement feature for engaging the inner member to axially shift the inner member from the first position to the second position.

13. The safety catheter of claim 12, wherein the engagement feature includes a protuberance.

14. The safety catheter of claim 1, wherein the inner member includes a stop member for engaging a portion of the needle cannula to axially shift the inner member from the first position to the second position.

15. The safety catheter of claim 14, wherein the stop member includes a stop washer.

16. The safety catheter of claim 1, wherein the inner member includes a second arm disposed opposite the at least one arm.

17. The safety catheter of claim 16, wherein the second arm is biased radially outward relative to the central axis.

18. The safety catheter of claim 1, wherein movement of the arm is constrained by the outer member when the inner member is in the second position.

19. The safety catheter of claim 1, wherein movement of the arm is constrained by the outer member when the inner member is in the first position.

29

20. The safety catheter of claim 1, wherein axial shifting of the inner member from the first position toward the second position moves the arm so as to block the path of the needle cannula.

21. The safety catheter of claim 1, wherein the inner member blocks the path of the needle cannula when the inner member is in the second position.

22. A safety catheter, comprising:

a catheter hub and a catheter tube extending distally thereof;
 a needle hub and a needle cannula extending distally thereof, the needle cannula having a distal tip; and
 a tip protector for shielding the distal tip, comprising an outer member including a flexible tab extending radially outward of the outer member configured to releasably engage with the interior of the catheter hub and to release therefrom on radially inward movement of the tab, and an inner member being axially received entirely within the outer member and having a portion to impede radially inward movement of the flexible tab when the inner member portion is disposed axially adjacent the flexible tab, the needle cannula being received in the inner and outer members, the inner member configured to be axially shiftable relative to the outer member between a first position wherein the distal tip extends distally of the tip protector and the inner member portion is disposed axially adjacent the flexible tab so as to impede release of the outer member from the catheter hub, and a second position wherein the distal tip is within the outer member, the inner member blocks the path of the needle cannula, and the inner member is axially shifted such that the inner member portion is no longer disposed axially adjacent the flexible tab such that inner member no longer impedes release of the outer member from the catheter hub, wherein the inner member includes a tapered bore having a cross dimension smaller than a cross dimension of the needle cannula to as to block the path of the needle cannula when the inner member is in the second position.

23. A safety catheter, comprising:

a catheter hub and a catheter tube extending distally thereof;
 a needle hub and a needle cannula extending distally thereof, the needle cannula having a distal tip; and
 a tip protector for shielding the distal tip, comprising an outer member including a flexible tab extending radially outward of the outer member configured to releasably engage with the interior of the catheter hub and to release therefrom on radially inward movement of the tab, and an inner member being axially received entirely within the outer member and having a portion to impede radially inward movement of the flexible tab when the inner member portion is disposed axially adjacent the flexible tab, the needle cannula being received in the inner and outer members, the inner member configured to be axially shiftable relative to the outer member between a first position wherein the distal tip extends distally of the tip protector and the inner member portion is disposed axially adjacent the flexible tab so as to impede release of the outer member from the catheter hub, and a second position wherein the distal tip is within the outer member, the inner member blocks the path of the needle cannula, and the inner member is axially shifted such that the inner member portion is no longer disposed axially adjacent the flexible tab such that inner member no longer impedes release of the outer member from the catheter hub, wherein the inner member includes at least

30

one rib that blocks the path of the needle cannula when the inner member is in the second position.

24. A safety catheter, comprising:

a catheter hub and a catheter tube extending distally thereof;
 a needle hub and a needle cannula extending distally thereof, the needle cannula having a distal tip; and
 a tip protector for shielding the distal tip, comprising an outer member including a flexible tab extending radially outward of the outer member configured to releasably engage with the interior of the catheter hub and to release therefrom on radially inward movement of the tab, and an inner member being axially received entirely within the outer member and having a portion to impede radially inward movement of the flexible tab when the inner member portion is disposed axially adjacent the flexible tab, the needle cannula being received in the inner and outer members, the inner member configured to be axially shiftable relative to the outer member between a first position wherein the distal tip extends distally of the tip protector and the inner member portion is disposed axially adjacent the flexible tab so as to impede release of the outer member from the catheter hub, and a second position wherein the distal tip is within the outer member and the inner member is axially shifted such that the inner member portion is no longer disposed axially adjacent the flexible tab such that inner member no longer impedes release of the outer member from the catheter hub, wherein the inner member includes at least one projection for limiting side out of the needle cannula when the inner member is in the second position.

25. The safety catheter of claim 24, wherein the inner member includes at least one notch configured to receive the at least one projection when the inner member is in the second position.

26. The safety catheter of claim 1, wherein the needle hub contacts the catheter hub when in a ready position of the safety catheter.

27. The safety catheter of claim 1, wherein the needle hub contacts the tip protector when in a ready position of the safety catheter.

28. A safety catheter, comprising:

a catheter hub and a catheter tube extending distally thereof;
 a needle hub and a needle cannula extending distally thereof, the needle cannula having a distal tip; and
 a tip protector for shielding the distal tip, comprising an outer member including a flexible tab extending radially outward of the outer member configured to releasably engage with the interior of the catheter hub and to release therefrom on radially inward movement of the tab, and an inner member being axially received entirely within the outer member and having a portion to impede radially inward movement of the flexible tab when the inner member portion is disposed axially adjacent the flexible tab, the needle cannula being received in the inner and outer members, the inner member configured to be axially shiftable relative to the outer member between a first position wherein the distal tip extends distally of the tip protector and the inner member portion is disposed axially adjacent the flexible tab so as to impede release of the outer member from the catheter hub, and a second position wherein the distal tip is within the outer member and the inner member is axially shifted such that the inner member portion is no longer disposed axially adjacent the flexible tab such that inner member no longer impedes release of the outer member from the catheter

31

hub, wherein the needle hub includes a distal nose portion having a plurality of spines extending therealong, wherein a distal end of the spines is distal of a distal end of the distal nose portion.

29. A safety catheter, comprising:

a catheter hub and a catheter tube extending distally thereof;

a needle hub and a needle cannula extending distally thereof, the needle cannula having a distal tip; and

a tip protector for shielding the distal tip, comprising an outer member including a flexible tab extending radially outward of the outer member configured to releasably engage with the interior of the catheter hub and to release therefrom on radially inward movement of the tab, and an inner member being axially received entirely within the outer member and having a portion to impede radially inward movement of the flexible tab when the inner member portion is disposed axially adjacent the flexible tab, the needle cannula being received in the inner and outer members, the inner member configured to be axially shiftable relative to the outer member between a first position wherein the distal tip extends distally of the tip protector and the inner member portion is disposed axially adjacent the flexible tab so as to impede release of the outer member from the catheter hub, and a second position wherein the distal tip is within the outer member and the inner member is axially shifted such that the inner member portion is no longer disposed axially adjacent the flexible tab such that inner member no longer impedes release of the outer member from the catheter hub, wherein the outer member includes at least one flexible locking tab, the inner member includes a groove having a cavity, the at least one flexible locking tab disposed in the groove and being received in the cavity when the inner member is in the second position to restrict axially shiftable movement of the inner member relative to the outer member.

30. The safety catheter of claim 1, the distal tip being sharp.

31. A safety catheter, comprising:

a catheter hub and a catheter tube extending distally thereof;

a needle hub and a needle cannula extending distally thereof, the needle cannula having a distal tip; and

a tip protector for shielding the distal tip, comprising an outer thin-walled metal body member extending into the catheter hub and including a flexible tab configured to releasably engage with the interior of the catheter hub and to release therefrom on radially inward movement of the tab, a plastic inner member having a portion to impede radially inward movement of the flexible tab when the inner member portion is disposed axially adjacent the flexible tab, the needle cannula being received in the inner and outer members, the inner member configured to be axially shiftable relative to the outer member between a first position wherein the distal tip extends distally of the tip protector and the inner member portion is disposed axially adjacent the flexible tab so as to impede release of the outer member from the catheter hub, and a second position wherein the distal tip is within the outer member and the inner member is axially shifted such that the inner member portion is no longer disposed axially adjacent the flexible tab such that the inner member no longer impedes release of the outer member from the catheter hub, and a metal stop member fixedly secured to the inner member for engaging a feature of the needle cannula adjacent the distal tip for axially shifting the inner member relative to the outer

32

member between the first and second positions with movement of the needle cannula, wherein the inner member includes a central axis and at least one arm, the arm being biased radially outward relative to the central axis.

32. The safety catheter of claim 31, wherein the stop member includes a central aperture through which the needle cannula is received.

33. The safety catheter of claim 31, wherein the stop member includes a stop washer.

34. The safety catheter of claim 31, wherein the feature on the needle cannula configured to engage the stop member is a protuberance.

35. The safety catheter of claim 31, wherein the inner member includes a multi-thickness body.

36. The safety catheter of claim 31, wherein the inner member includes a tapered bore having a cross dimension smaller than a cross dimension of the needle cannula to as to block the path of the needle cannula when the inner member is in the second position.

37. The safety catheter of claim 31, wherein the inner member includes at least one rib that blocks the path of the needle cannula when the inner member is in the second position.

38. The safety catheter of claim 31, wherein the inner member includes at least one projection for limiting side out of the needle cannula when the inner member is in the second position.

39. The safety catheter of claim 38, wherein the inner member includes at least one notch configured to receive the at least one projection when the inner member is in the second position.

40. The safety catheter of claim 31, the distal tip being sharp.

41. A safety catheter, comprising:

a catheter hub and a catheter tube extending distally thereof;

a needle hub and a needle cannula extending distally thereof, the needle cannula having a distal tip; and

a tip protector for shielding the distal tip, comprising an outer member including a flexible tab configured to releasably engage with the interior of the catheter hub and to release therefrom on radially inward movement of the tab, and an inner member having a portion to impede radially inward movement of the flexible tab when the inner member portion is disposed axially adjacent the flexible tab, the needle cannula being received in the inner and outer members, the inner member configured to be axially shiftable relative to the outer member between a first position wherein the distal tip extends distally of the tip protector and the inner member portion is disposed axially adjacent the flexible tab so as to impede release of the outer member from the catheter hub, and a second position wherein the distal tip is within the outer member and the inner member is axially shifted such that the inner member portion is no longer disposed axially adjacent the flexible tab such that inner member no longer impedes release of the outer member from the catheter hub, the inner member having an arm having a portion configured to block the path of the needle cannula when in the second position, the arm being biased away from the needle cannula such that the arm is spaced therefrom when in at least the first position.

42. The safety catheter of claim 41, wherein movement of the arm is constrained by the outer member when the inner member is in the second position.

33

43. The safety catheter of claim 41, wherein movement of the arm is constrained by the outer member when the inner member is in the first position.

44. The safety catheter of claim 41, wherein axial shifting of the inner member from the first position toward the second position moves the arm so as to block the path of the needle cannula.

45. The safety catheter of claim 41, wherein the inner member includes a tapered bore having a cross dimension smaller than a cross dimension of the needle cannula so as to block the path of the needle cannula when the inner member is in the second position.

46. The safety catheter of claim 45, wherein the inner member includes a pair of arms, each arm having a tapered bore portion such that when the inner member is in the closed position, the tapered bore portions collectively define the tapered bore.

47. The safety catheter of claim 41, wherein the arm includes at least one rib that at least in part blocks the path of the needle cannula when the inner member is in the second position.

48. The safety catheter of claim 47, wherein the at least one rib is spaced from the needle cannula when the inner member is in the first position.

49. The safety catheter of claim 47, wherein the inner member includes a pair of arms, each arm having at least one rib, the ribs cooperating to block the path of the needle cannula when the inner member is in the second position.

50. The safety catheter of claim 41, wherein the arm includes at least one projection for limiting side out of the needle cannula when the inner member is in the second position.

51. The safety catheter of claim 50, wherein the inner member includes a pair of arms, one arm having at least one projection for limiting side out of the needle cannula, the other arm having at least one notch configured to receive the at least one projection when the inner member is in the second position.

52. The safety catheter of claim 41, wherein the catheter hub includes at least one wing.

34

53. The safety catheter of claim 41, wherein the catheter hub includes a side port.

54. The safety catheter of claim 41, the distal tip being sharp.

55. A safety catheter, comprising:

a catheter hub and a catheter tube extending distally thereof;

a needle hub and a needle cannula extending distally thereof, the needle cannula having a distal tip; and

a tip protector for shielding the tip, comprising an outer member including a flexible tab extending radially outward of the outer member configured to releasably engage with the interior of the catheter hub and to release therefrom on radially inward movement of the tab, and an inner member having a portion to impede radially inward movement of the flexible tab when the inner member portion is disposed axially adjacent the flexible tab, the needle cannula being received in the inner and outer members, the inner member configured to be axially shiftable relative to the outer member between a first position wherein the tip extends distally of the tip protector and the inner member portion is disposed axially adjacent the flexible tab so as to impede release of the outer member from the catheter hub, an intermediate position wherein the inner member blocks the path of the needle cannula, the inner member is prevented from axially shifting relative to the outer member in at least one direction, and the inner member portion remains disposed axially adjacent the flexible tab so as to impede release of the outer member from the catheter hub, and a second position wherein the inner member is axially shifted such that the inner member portion is no longer disposed axially adjacent the flexible tab such that the inner member no longer impedes release of the outer member from the catheter hub, wherein the inner member includes a central axis and at least one arm, the arm being biased radially outward relative to the central axis.

56. The safety catheter of claim 55, the distal tip being sharp.

* * * * *