

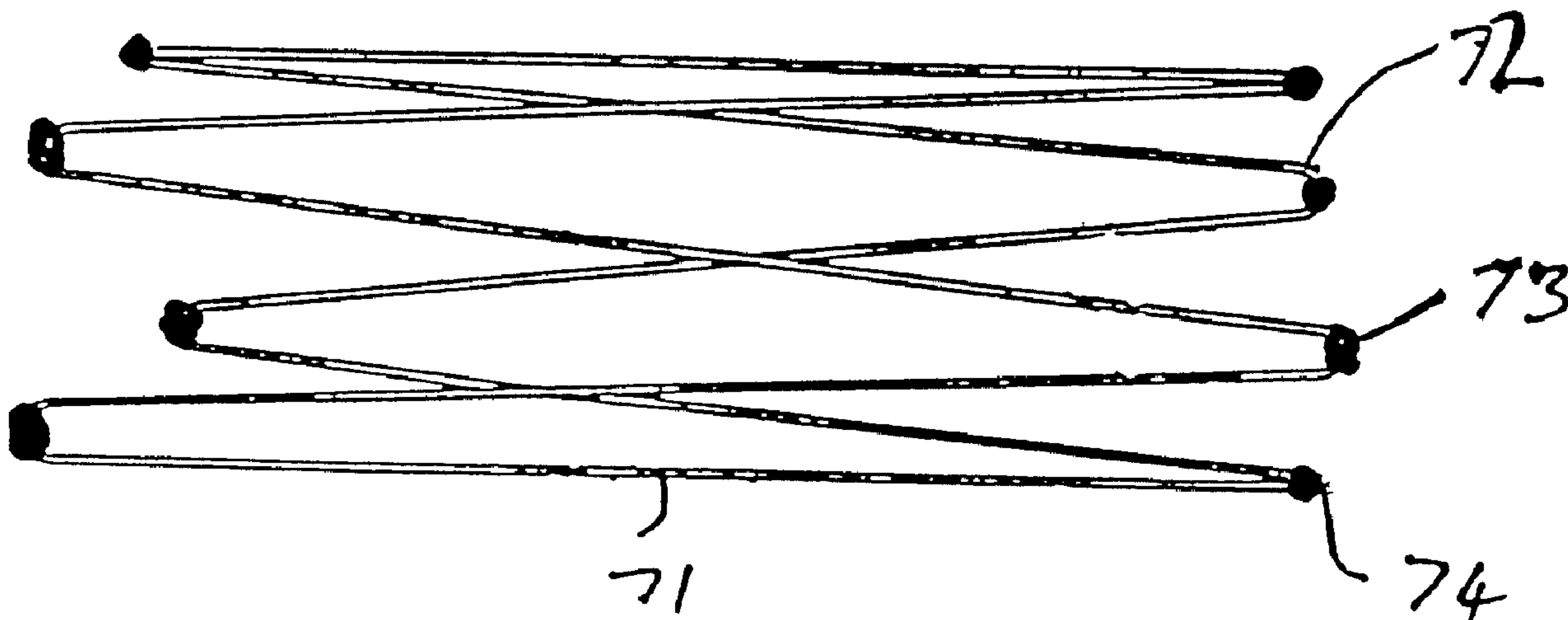

(22) Date de dépôt/Filing Date: 1996/11/20
 (41) Mise à la disp. pub./Open to Public Insp.: 1997/06/08
 (45) Date de délivrance/Issue Date: 2003/06/10
 (62) Demande originale/Original Application: 2 190 794
 (30) Priorité/Priority: 1995/12/07 (08/568,834) US

(51) Cl.Int.⁷/Int.Cl.⁷ A61F 2/06, B23P 15/00
 (72) Inventeurs/Inventors:
 LASHINSKI, ROBERT, US;
 BIRDSALL, MATTHEW, US
 (73) Propriétaire/Owner:
 MEDTRONIC AVE, INC., US
 (74) Agent: CASSAN MACLEAN

(54) Titre : EXTENSEUR PERMETTANT UN MEILLEUR DEPLOIEMENT TRANSLUMINAL
 (54) Title: STENT FOR IMPROVED TRANSLUMINAL DEPLOYMENT



(57) Abrégé/Abstract:

A stent and method for manufacturing a stent comprising an expandable, generally tubular body portion in which one or both ends of the stent are provided with a generally rounded, smooth radiused portion that forms a bulbous protrusion out of the plane of the circumference of the stent. The design of the stent increases the profile of the end of the stent and decreases the risk of injury or vessel dissection during stent deployment.

Abstract

A stent and method for manufacturing a stent comprising an expandable, generally tubular body portion in which one or both ends of the stent are provided with a generally rounded, smooth radiused portion that forms a bulbous protrusion out of the plane of the circumference of the stent. The design of the stent increases the profile of the end of the stent and decreases the risk of injury or vessel dissection during stent deployment.

AVE-008

This application is a division of Application Serial Number 2,190,794, filed in Canada on November 20, 1996

STENT FOR IMPROVED TRANSLUMINAL DEPLOYMENT

Field Of The Invention

This invention relates to medical implant
5 devices. More specifically, the invention relates to
an improved implantable stent apparatus for the
treatment of stenoses in coronary or peripheral vessels
in humans.

Background Of The Invention

10 Cardiovascular disease, including
atherosclerosis, is the leading cause of death in the
United States. The medical community has developed a
number of methods and devices for treating coronary
heart disease, some of which are specifically designed
15 to treat the complications resulting from
atherosclerosis and other forms of coronary artery
narrowing.

An important development for treating
atherosclerosis and other forms of coronary narrowing
20 is percutaneous transluminal coronary angioplasty,
hereinafter referred to as "angioplasty" or "PTCA".
The objective in angioplasty is to enlarge the lumen of
the affected coronary artery by radial hydraulic
expansion. The procedure is accomplished by inflating
25 a balloon within the narrowed lumen of the coronary
artery. Radial expansion of the coronary artery occurs
in several different dimensions, and is related to the

nature of the plaque. Soft, fatty plaque deposits are flattened by the balloon, while hardened deposits are cracked and split to enlarge the lumen. The wall of the artery itself is also stretched when the balloon is
5 inflated.

Unfortunately, while the affected artery can be enlarged, in some instances the vessel restenoses chronically, or closes down acutely, negating the positive effect of the angioplasty procedure. In the
10 past, such restenosis has frequently necessitated repeat PTCA or open heart surgery. While such restenosis does not occur in the majority of cases, it occurs frequently enough that such complications comprise a significant percentage of the overall
15 failures of the PTCA procedure, for example, twenty-five to thirty-five percent of such failures.

To lessen the risk of restenosis, various devices have been proposed for mechanically keeping the affected vessel open after completion of the
20 angioplasty procedure. Such endoprotheses (generally referred to as "stents"), are typically inserted into the vessel, positioned across the lesion or stenosis, and then expanded to keep the passageway clear. The stent overcomes the natural tendency of the vessel
25 walls of some patients to restenose, thus maintaining the patency of the vessel.

Various types of stents are currently under development, although to date none has proven completely satisfactory during testing. U.S. Patent
30 4,655,771 to Wallsten describes a stent comprising a tube of stainless wire braid. During insertion, the tube is positioned along a delivery device, such as a catheter, in extended form, making the tube diameter as small as possible. When the stent is positioned across
35 the lesion, it is expanded, causing the length of the tube to contract and the diameter to expand. Depending

on the materials used in construction of the stent, the tube maintains the new shape either through mechanical force or otherwise.

U.S. Patent No. 4,733,665 to Palmaz describes
5 a stent comprising a slotted stainless steel cylinder that forms a mesh when expanded. The stent is delivered to an affected area by a balloon catheter, and is then expanded to the proper size by inflating the balloon.

10 Stents are typically delivered to affected areas of vessels using standard catheterization techniques. A thin walled hollow guiding catheter is introduced into the body via a relatively large vessel, such as the femoral artery in the groin area or the
15 brachial artery in the arm by insertion through a hollow sheath. The guiding catheter is maneuvered through an approximately 180 degree turn through the aortic arch to descend into the aortic cusp where entry may be gained to either the left or the right coronary
20 artery, as desired.

A flexible guidewire is inserted into the guiding catheter and advanced to the area to be treated. The guidewire is advanced across the lesion in preparation for the advancement of a catheter across
25 the guide wire. Typically a balloon catheter carrying the stent is then introduced over the guidewire to the area to be treated. Radiopaque markers in the balloon segment of the catheter facilitate positioning across the lesion. The balloon catheter is then inflated with
30 contrast material to permit fluoroscopic viewing during treatment. The balloon is inflated until the lumen of the artery is satisfactorily enlarged and the stent is in place.

During delivery of the stent, the stent and
35 balloon catheter must navigate narrow tortuous vessels into the site of a stenosis. Typically, the balloon

and stent are covered with a sheath during delivery. Such sheaths facilitate delivery of stents because the sheath prevents the stent from being dislodged from the delivery device. However, sheaths increase the cross-sectional profile of the stent, necessitating use of a guiding catheter with a larger internal diameter. The large diameter of the guiding catheter may increase the risk of complications at the patient access site. Moreover, the larger cross-sectional profile of the stent delivery system may decrease the ability to deliver contrast material through the guiding catheter to enable precise positioning. More important, an increased cross-sectional profile may make it impossible to deliver a stent through narrow and tortuous vessels to the area desired to be treated.

Stent delivery systems without sheaths have been proposed. For example, the Boneau stent described in U.S. Patent 5,292,331 has been used with a modified delivery device described in co-pending PCT Application number WO 96/12517, published on May 2, 1996. The disclosed delivery system secures the stent on the outside of the balloon without the need for a sheath.

However, attempts to deliver expandable stents without using a delivery sheath have resulted in a number of problems. First the relatively rigid stent may be dislodged from the more pliable balloon material of the flexible delivery device when contact occurs between the vessel wall and the stent, particularly during passage through a curve. Additionally, the low mass of the rigid stents, and construction methods of some stents, causes the end portions to have small cross-sections and to be somewhat rigid and sharp. The small, sharp, cross-sections at the ends of the stents increase the risk that a stent will penetrate the vessel wall, particularly when the narrow, rigid

5 end of a stent encounters a curve in a vessel. The flexible delivery device and balloon material follow the contours of the vessel, and when negotiating a curve, the distal end of the more rigid stent may separate slightly from the balloon and delivery device. The separated, sharp distal end may cause abrasion or penetrate the soft tissues of the vessel wall.

These and other complications have resulted in a low level of acceptance for such stents within the medical community for certain procedures, and to date stents have not been accepted as a practical method for treating many chronic restenosis conditions.

10 It would therefore be desirable to provide methods and apparatus, useful for treating chronic restenosis conditions, that enable delivery of a stent without a sheath and which reduce the risk of vessel abrasion and dissection during delivery.

Summary of the Invention

15 In view of the foregoing, it is an object of this invention to provide methods and apparatus, useful for treating chronic restenosis conditions, that enable delivery of a stent without a sheath and which reduce the risk of vessel abrasion and dissection during delivery.

20 A stent constructed in accordance with this invention may be in the form of an expandable, generally tubular body portion having two ends, wherein at least one end of the stent is provided with a generally rounded, smooth radius.

25 In one aspect, the invention therefore provides, a stent for implantation within a lumen of a vessel within the human body having a first diameter that permits intraluminal delivery and second expanded diameter wherein the stent supports a lumen of a body passageway. The stent comprises a plurality of N substantially straight segments of wire-like material, each segment having first and second ends, the first end of the first segment being connected to the first end of the second segment at a first apex, the second end of the second segment being connected to the second end of the third segment at a second apex, and so on until the second end of the Nth segment is connected to the second end of the first segment at the Nth apex. The improvement comprises a radiused or bulbous portion disposed on each odd-numbered apex and increasing the profile of the apex to reduce the risk of injury to the lumen of the body passageway during

30

introduction of the stent.

In another aspect, the invention provides a method of manufacturing a stent having a first diameter that permits intraluminal delivery and second expanded diameter wherein the stent supports a lumen of a body passageway, the method comprising the steps of providing a tubular member having two ends and a plurality of apices at each end increasing the profile of a plurality of the apices so as to reduce the risk of injury to the lumen of the body passageway during introduction of the stent.

In a further aspect, the invention provides an endoprosthesis device comprising a generally cylindrical, tubular support member having first and second ends having a first diameter that permits intraluminal delivery and a second expanded diameter . There is a wall surface disposed between the first and second ends, the wall surface being formed by a plurality of intersecting elongate members, at least some of the elongate members intersecting with one another immediate the first and second ends of the tubular shaped member. A radiused portion is disposed on the first end of the tubular support member to reduce the risk of injury to a lumen of a body passageway during introduction of the endoprosthesis device, wherein the radiused portion does not increase the profile of the device.

In a further aspect, the invention provides an endovascular support device for implantation within a vessel having a first diameter that permits intraluminal delivery and a second expanded diameter wherein the stent supports a lumen of a body passageway. The device comprises a member formed of a plurality of substantially straight segments and configured to provide a plurality of upper and lower peaks and a radiused portion disposed on at least one of the upper peaks to reduce the risk of injury to a vessel during introduction of the endovascular support device, wherein the radiused portion does not increase the profile of the device.

The deployment methods for implementing a stent constructed in accordance with the present invention include balloon expansion, self-expansion, self-retraction and mechanical expansion. Some of the intended uses include PTCA type stenting, PTA type

stenting, graft support, graft delivery, INR use, GI tract use, drug delivery, and biliary stenting.

Brief Description Of The Drawings

FIG. 1 is an elevational sectional view of an illustrative prior art stent attempting to negotiate a curve in a narrow vessel.

FIG. 2 is an elevational sectional view of an illustrative stent according to the present invention attempting to negotiate a curve in a narrow vessel.

FIGS. 3A-3B show respectively, perspective and end views of an illustrative prior art mesh stent.

FIGS. 4A-4B show respectively, perspective and end views of an illustrative mesh stent constructed in accordance with the present invention and having bulbous portions created by bending the material of the stent wall at the apices of the stent outward.

FIGS. 5A-5B show respectively, perspective and end views of an illustrative mesh stent constructed in accordance with the present invention and having bulbous portions created by providing extra material at the apices of the stent.

FIGS. 6 shows a perspective view of an illustrative mesh stent constructed in accordance with the present invention and having a radius formed at the apices of the stent in the plane of the wall of the stent.

FIGS. 7A-7C show respectively, a prior art expandable wire-type stent, and two alternative embodiments of a stent similar to the stent of FIG. 7A but which additionally incorporate features of the present invention.

FIGS. 8A-8B show respectively, a perspective view of an illustrated stent constructed in accordance with the present invention, and a cross-section taken along line AA.

Detailed Description Of The Invention

In overview, an endoprosthesis constructed in accordance with the present invention comprises an expandable, generally tubular body portion having two

ends. In accordance with the present invention, at least one end of the stent is provided with a generally rounded, smooth radiused portion that forms a bulbous protrusion out of the plane of the circumference of the stent. The methods and apparatus of the present invention are illustratively described with respect to the low-mass, unitary mesh-like stent structure described in U.S. Patent 4,733,665. It will of course be understood that the present invention is not limited to that stent structure, but is generally applicable to previously known stents such as those described above to reduce the potential for vessel abrasion and dissection during delivery.

FIG. 1 is a diagrammatic side view of prior art stent 11 shown compressed on a delivery device, in this case on balloon 12 of balloon catheter 13. Stent 11 is shown attempting to negotiate a curve while passing through the lumen of narrow vessel 14. Distal end 15 of substantially rigid stent 11 separates from the pliable balloon material and flexible catheter 13 as catheter 13 and balloon 12 curve to follow the contour of the vessel 14. The separation is illustratively shown as gap 16. Distal end 15 contacts intima 17 of vessel 14 because substantially rigid metallic stent 11 does not bend around the curve in the vessel wall as readily as flexible catheter 13 and pliable balloon 12. Depending upon the condition of vessel 14, contact by distal end 15 of stent 11 may cause abrasion to intima 17, or even dissection of vessel 14. More important, it may be impossible to deliver stent 11 to the desired location in vessel 14 if stent 11 cannot be maneuvered through the turn.

FIGS. 3A-3B show views of a typical mesh stent 31 such as described in Palmaz U.S. Patent 4,733,665. FIG. 3A is a perspective view of the entire stent while FIG. 3B shows an end view of the stent. In

FIG. 3A the apices 32 of the stent are shown having right-angled corners 33. It is believed that the sharpness of these corners in combination with the thin profile of the flat end of the apices 32 contribute to the poor trackability of this stent when used without a sheath. In FIG. 3B the small profile presented by the apices 32 of the stent 31 to the vessel wall is readily observed. The thickness of the stent material in such stents is typically less than 0.005 inches.

10 Referring now to FIG. 2 which is illustrative of a stent 21 embodying the principles of the present invention as described. Items common with FIG. 1 are numbered identically with those of FIG. 1. Distal end 22 and proximal end 23 of stent 21 are provided with a radiused or bulbous portion 20 that protrudes beyond the outer circumference of the stent to increase the surface area of ends 22, 23. Bulbous portion 20 eliminates any sharp edges in the formation of stent 21 which may be formed of thin material. As stent 21 negotiates a curve, the curved surface reduces the risk that the ends of stent 21 will penetrate vessel 14.

Referring now to FIGS. 4A-4B, 5A-5B, radiused portions formed by several methods are shown. It is apparent from these figures that the apex of the stents of the present invention presents a larger radius profile to the wall of the vessel than does the apex of the prior art device shown in FIGS. 3A and 3B.

Stent 41 of FIGS. 4A-4B is formed by bending outward the stent material in the region of apex 42 of the stent. As shown in FIG. 4B the bending of the stent material adds radius 43 to the apex 42 of stent 41. As shown in FIG. 4B the bending of the stent material increases the profile of apex 42 that is presented to the wall of the vessel, thus reducing risk of injury or dissection.

Stent 51 of FIGS. 5A-5B is formed by adding material 54 in the region of apex 52 of the stent. As shown in FIG. 5B the additional material adds radius 53 to the apex 52 of stent 51. As shown in FIG. 5B the additional material increases the profile of apex 52 that is presented to the wall of the vessel, thus reducing risk of injury or dissection.

The material 54 added in the region of the apex may have the same composition as the material of the stent or alternatively may have a different composition. For example the added material may be a metal or a non-metal. Metal material may be added to the radius in molten or powdered form and solidified around the apex using conventional metallurgical and soldering techniques. In addition, the radiused or bulbous portion may then be polished if desired to eliminate any irregularities.

A polymer material may also be formed around the apex of the stent in powdered or molten form. Alternatively, heat-shrink plastic elements may be inserted over portions of the stent and heat treated at the apex locations. Where a polymer is chosen to create the radiused portion, a suitable biocompatible polymer may be chosen which forms a good bond with the vessel over time. This integration of the ends of the stent with the intima of the vessel wall is expected to have the additional benefit of anchoring the stent over time.

The additional material at the apex of stent 51 in the region of apex 52 may also be provided by thickening the stent. For example, the apex of a stent such as stent 31 of FIG. 3A may be heated to form a bead of softened or molten stent material which forms the radius when cooled as, illustrated by stent 51 of FIG. 5A. The radius 53 may then be polished if desired to eliminate any irregularities. The thicker stent

material adds radius 53 to apex 52 of stent 51. This additional thickness of the material increases the profile of apex 52 of stent 51 that is presented to the wall of the vessel as described hereinabove. It will
5 be recognized by those skilled in the art that the increased thickness of material forming the radius at an apex of stent 51 also may be provided by using powder metallurgy techniques or selective machining.

Stent 61 of FIG. 6 illustrates an
10 alternative embodiment of the present invention in which the apex of the stent is provided with a radius in the plane of the wall of the stent. The apices 62 of stent 61 are rounded off at the edges 63. It is believed that while not necessarily increasing the
15 thickness of stent 61 in the region of apices 62 of the stent, the radius provided by rounding the apices of the stent will improve trackability of the stent. The profile of the stent may additionally be increased by forming another radius on the stent by adding material
20 in the region of the apices 62 as shown in FIGS. 5A and 5B.

The stent of FIGS. 7A-7C is illustratively formed from a wire structure for example, like the stent described in Boneau U.S. Patent 5,292,331. Such
25 wire-type stents can be manufactured either by bonding together separate elements into the desired configuration or by bending a unitary piece of wire-like material. According to the present invention, a radiused portion can be provided on such stents by
30 adding material or thickening the wire-like material at the apices of the stent as described above with respect to FIGS. 5A-5B. Referring to FIG. 7B the additional material 73 adds a radius 74 to stent 72 that increases the profile of apex 72 of stent 71. Stent 71 of FIG.
35 7C is formed by providing a twist 75 in the wire in the region of apex 72 of the stent to form radiused portion

76. The bending of the apex adds radius 76 to the stent 71. The radius increases the profile of apex 72 of stent 71, as described hereinabove.

Stent 81 of FIGS. 8A-8B illustrate a further
5 embodiment of the present invention in which at least one end, and preferably both ends, of the stent is provided with a generally rounded, smooth radius. The apices 82 of stent 81 are rounded off or radiused at
10 edges 83. Without increasing the profile, and/or thickness, of stent 81 in the region of apices 82, the radius provided by rounding apices 82 will improve the trackability of stent 81.

The present invention provides further advantages during deployment, as described hereinabove.
15 The stent and radii are preferably formed from radiopaque materials. Since there typically is more material in the end regions of the stents of the present invention compared to the stents of the prior art, the increased amount of radiopaque material at the
20 ends of the stent are more clearly outlined during deployment, thereby assisting accurate placement of the stent.

While one application for the above-described stent includes treatment of cardiovascular disease such
25 as atherosclerosis or other forms of coronary narrowing, the present invention may also be used for treatment of narrowed vessels in other components of the vascular system, for example, the kidney, leg, carotid artery, or elsewhere in the body. As will of
30 course be appreciated, the size of the stent, as well as its external characteristics, may need to be adjusted to compensate for the differing sizes of the vessel to be treated.

While this invention has been described in connection with an illustrative preferred embodiment thereof, modifications and changes may be made thereto by those skilled in the art without departing from the spirit and scope of the invention. Accordingly, the scope of this invention is to be limited only by the appended claims.

WHAT IS CLAIMED IS:

- 5
10
15
20
25
30
1. In a stent for implantation with a lumen of a vessel within the human body having a first diameter that permits intraluminal delivery and second expanded diameter wherein the stent supports a lumen of a body passageway, the stent comprising a plurality of N substantially straight segments of wire-like material, each segment having first and second ends, the first end of the first segment being connected to the first end of the second segment at a first apex, the second end of the second segment being connected to the second end of the third segment at a second apex, and so on until the second end of the Nth segment is connected to the second end of the first segment at the Nth apex, the improvement comprising:
a radiused or bulbous portion disposed on each odd-numbered apex and increasing the profile of the apex to reduce the risk of injury to the lumen of the body passageway during introduction of the stent.
 2. The stent as defined in claim 1 wherein each even-numbered apex is provided with a radiused or bulbous portion.
 3. The stent as defined in claim 1 wherein the radiused or bulbous portion is formed by adding material to each odd-numbered apex out of the plane of a circumference of the stent.
 4. The stent as defined in claim 3 wherein the material has a different composition than the stent.
 5. The stent as defined in claim 1 wherein the radiused or bulbous portion is formed by thickening of the apex of the stent.
 6. The stent as defined in claim 5 wherein the radiused or bulbous portion is formed by a step of heating the apex of the stent.
 7. The stent as defined in claim 6 wherein the step of heating the stent is

accomplished using a laser.

8. The stent as defined in claim 7 wherein the radiused or bulbous portion is formed by bending the odd-numbered apices of the stent.

5

9. A method of manufacturing a stent having a first diameter that permits intraluminal delivery and second expanded diameter wherein the stent supports a lumen of a body passageway, the method comprising the steps of:

10

providing a tubular member having two ends and a plurality of apices at each end;

increasing the profile of a plurality of the apices so as to reduce the risk of injury to the lumen of the body passageway during introduction of the stent.

15

10. The method as defined in claim 9 wherein the step of increasing the profile of a plurality of the apices comprises the step of adding material to the apex out of the plane of a circumference of the stent.

20

11. The method as defined in claim 10 wherein the step of increasing the profile of a plurality of the apices comprises the step of adding a polymer material to the apex out of the plane of a circumference of the stent.

25

12. The method as defined in claim 9 wherein the step of increasing the profile of a plurality of the apices comprises the step of thickening an apex of the stent.

13. The method as defined in claim 12 wherein the step of thickening an apex of the stent comprises the step of heating an apex of the stent.

30

14. The method as defined in claim 13 wherein the step of heating an apex of the stent comprises the step of directing a laser at the apex of the stent.

15. The method as defined in claim 9 wherein the step of increasing the

profile of a plurality of the apices comprises the step of twisting the apex of the stent out of the plane of a circumference of the stent.

5

CASSAN, MACLEAN
Suite 401, 80 Aberdeen Street
Ottawa, Canada
K1S 5R5

10

Agents for the Applicant

Figure 1. Prior Art

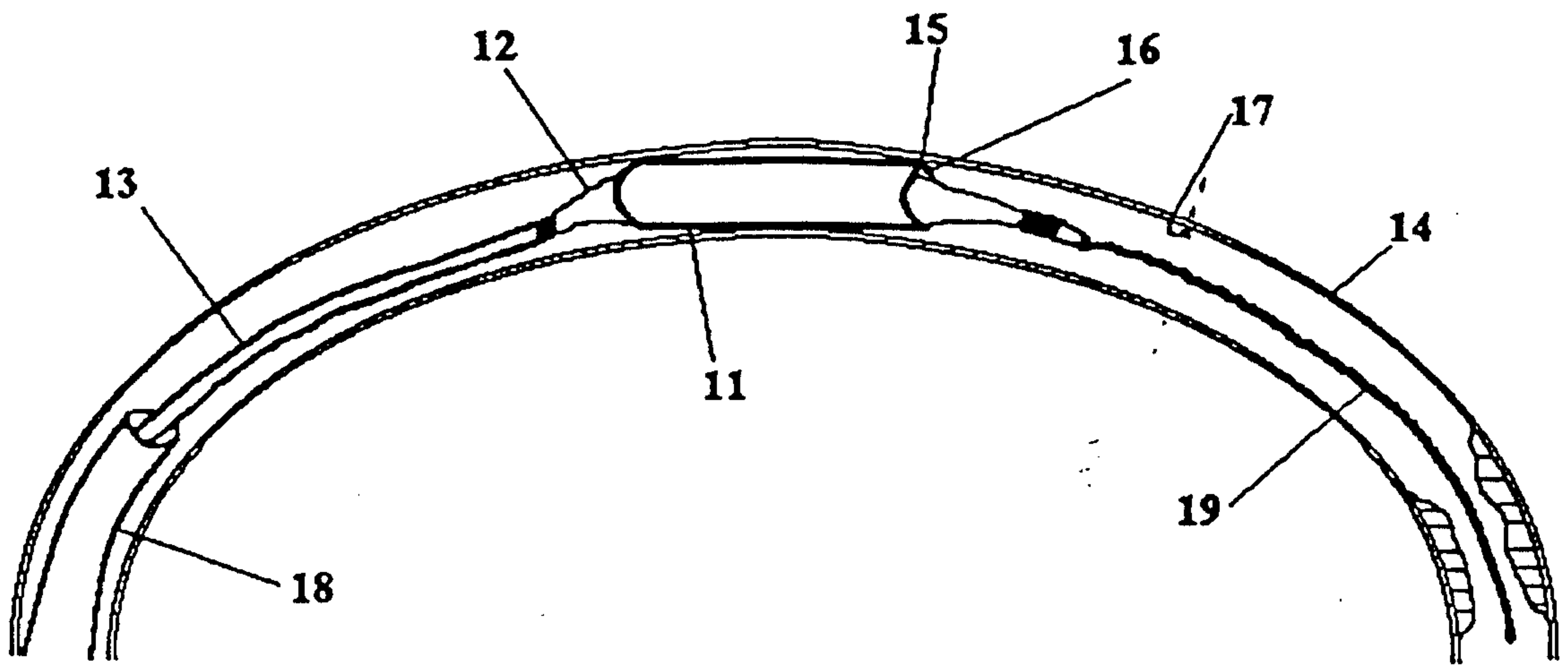

Figure 2.

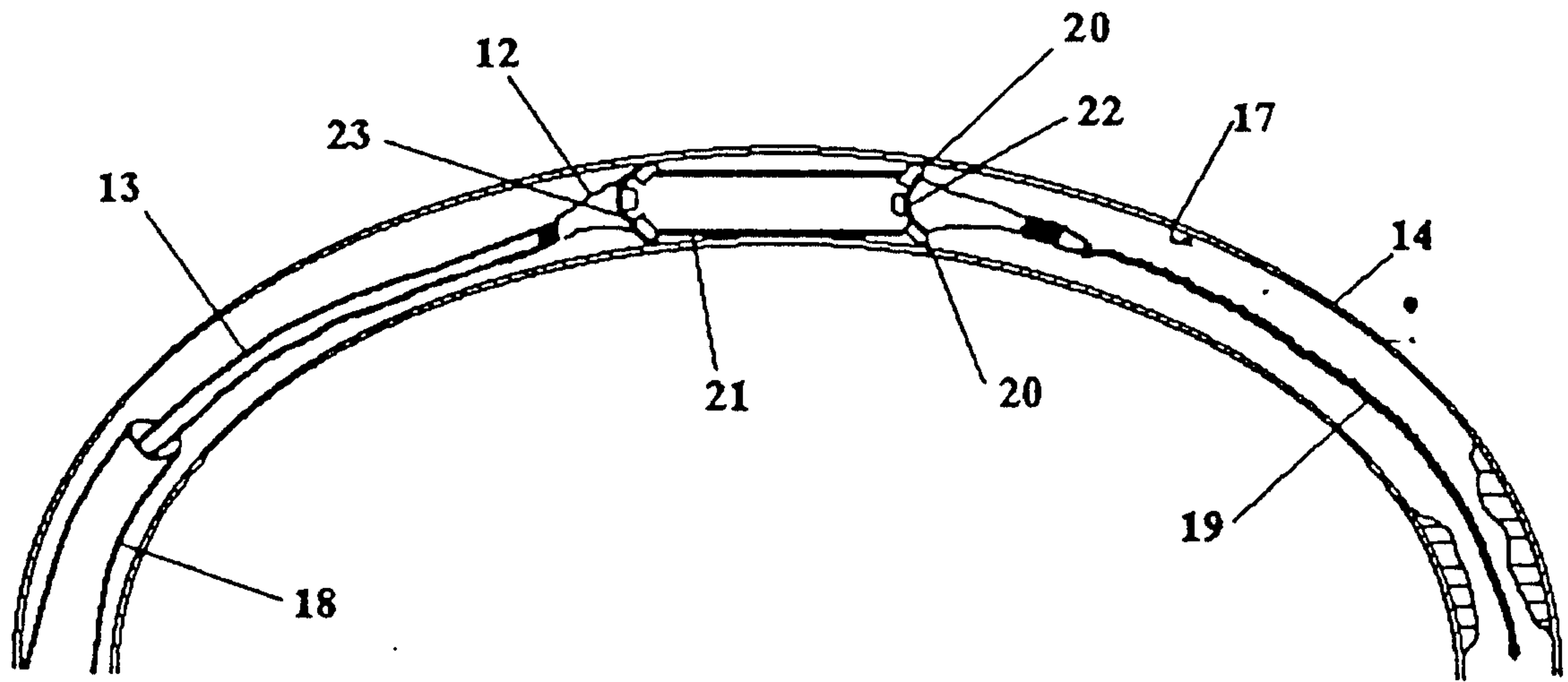

Figure 3A PRIOR ART

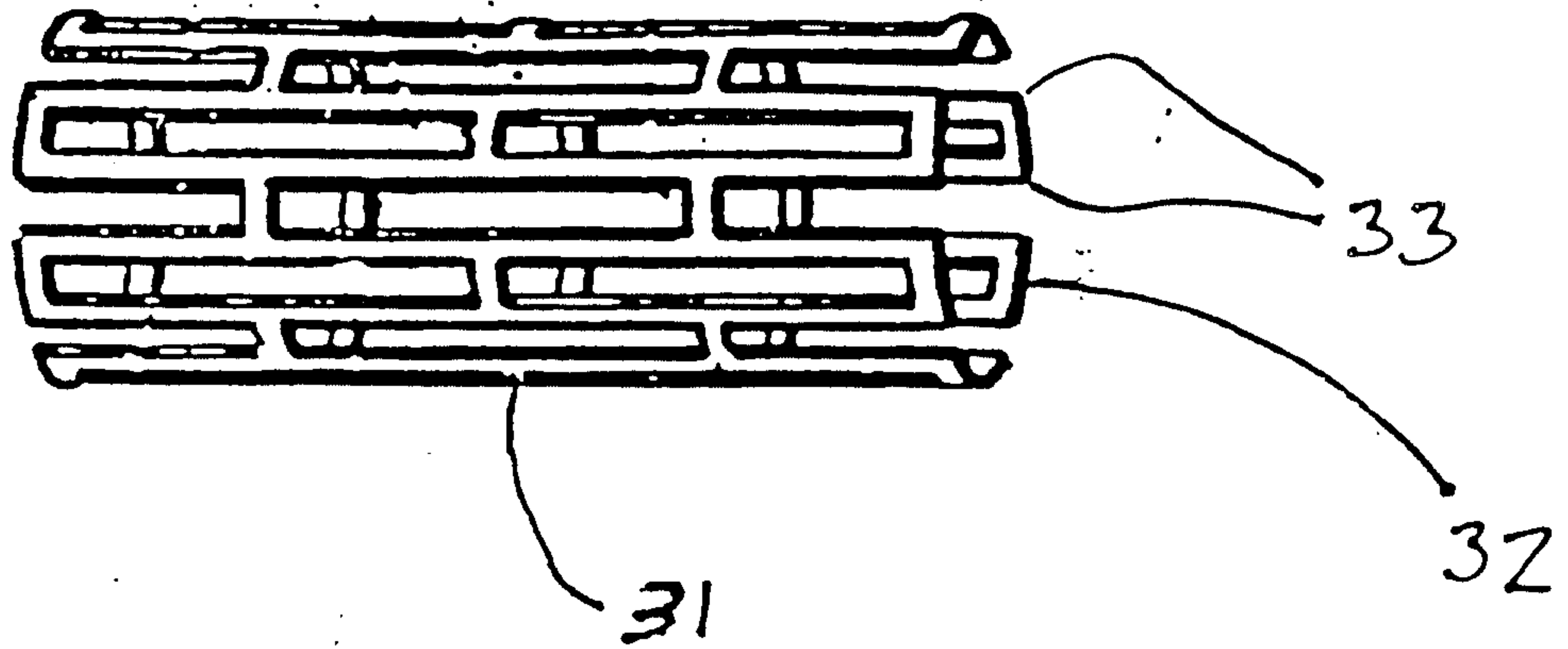

Figure 3B PRIOR ART

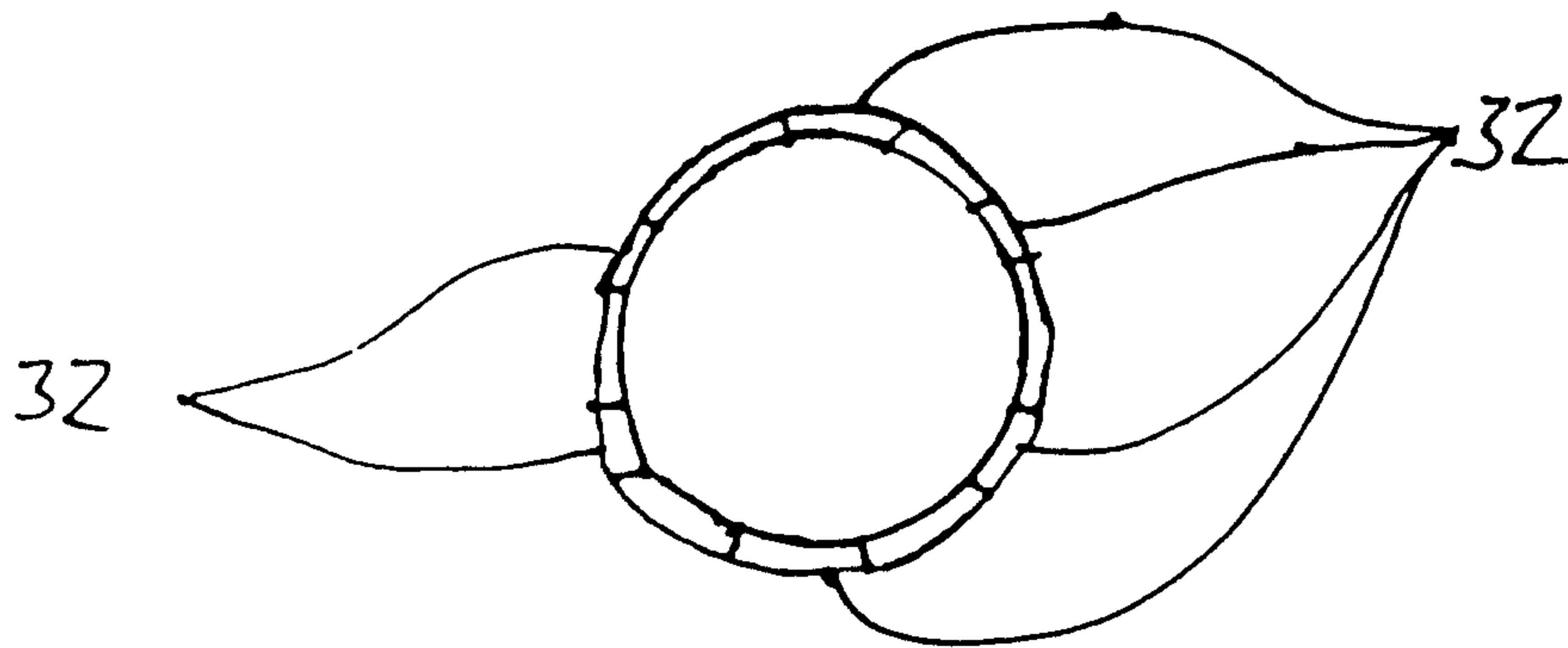

Figure 4A

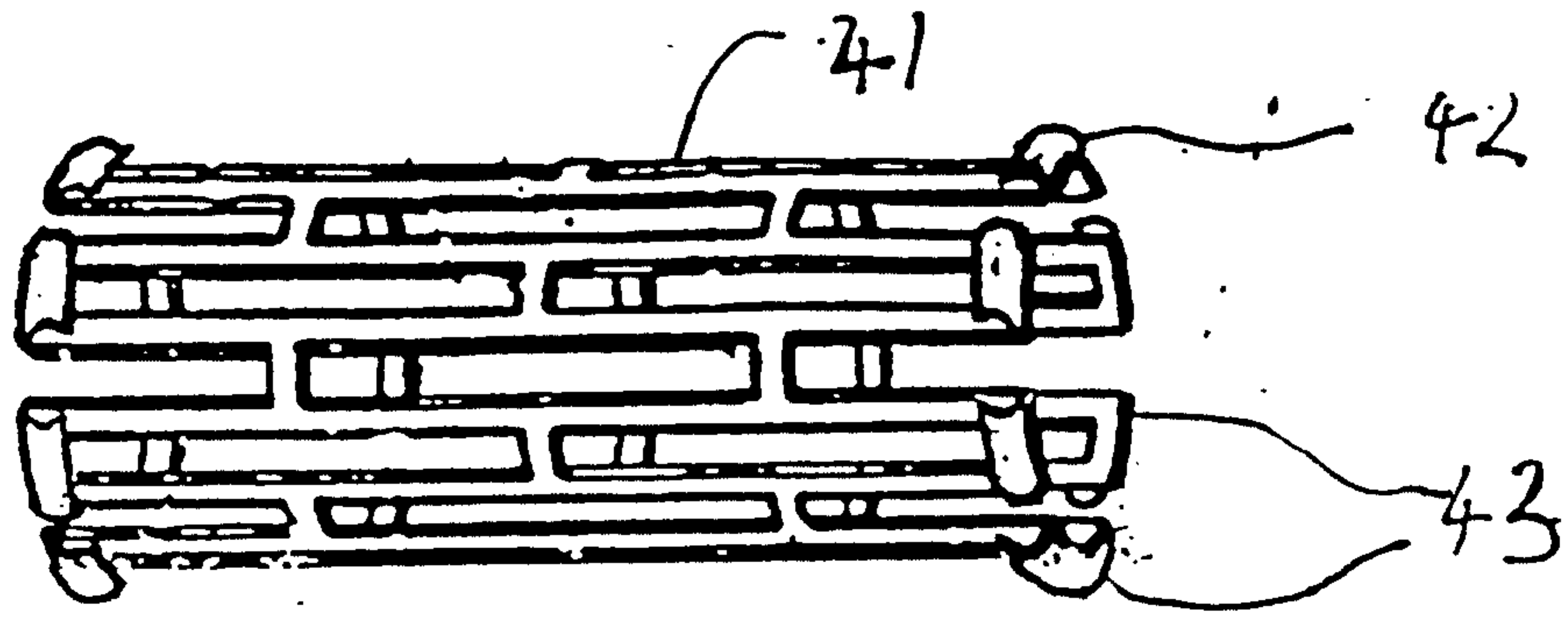

Figure 4B

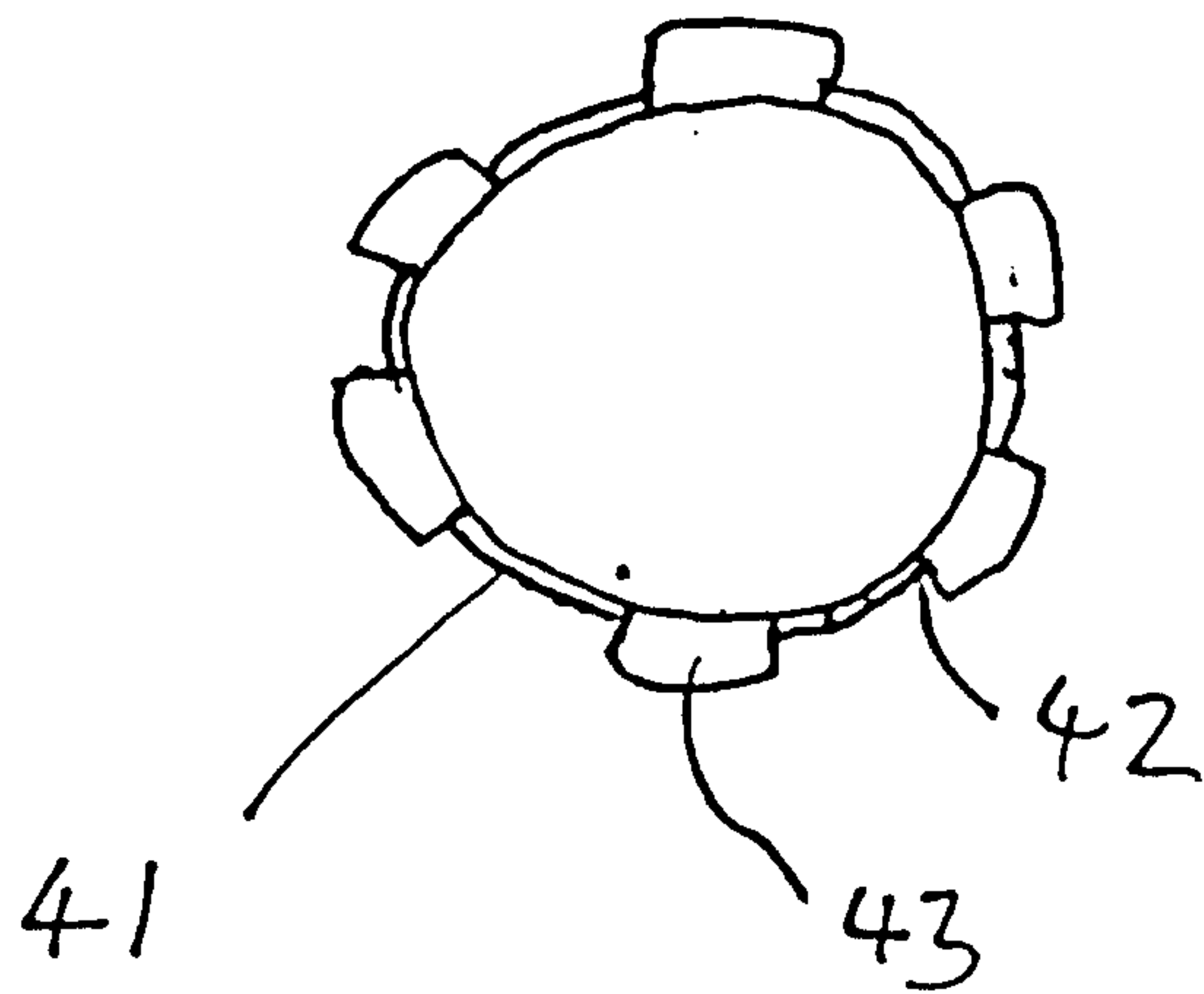

Figure 5A

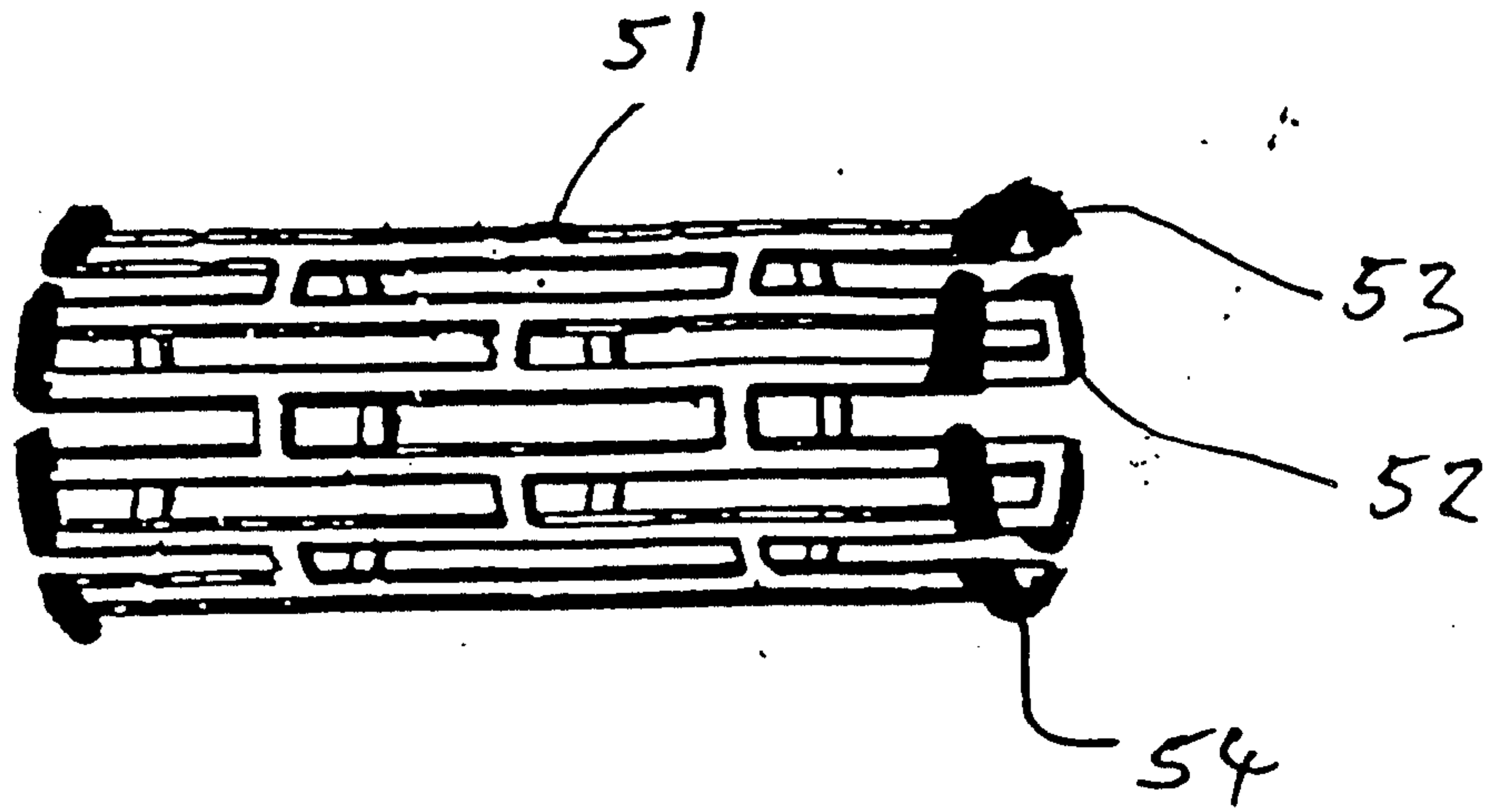

Figure 5B

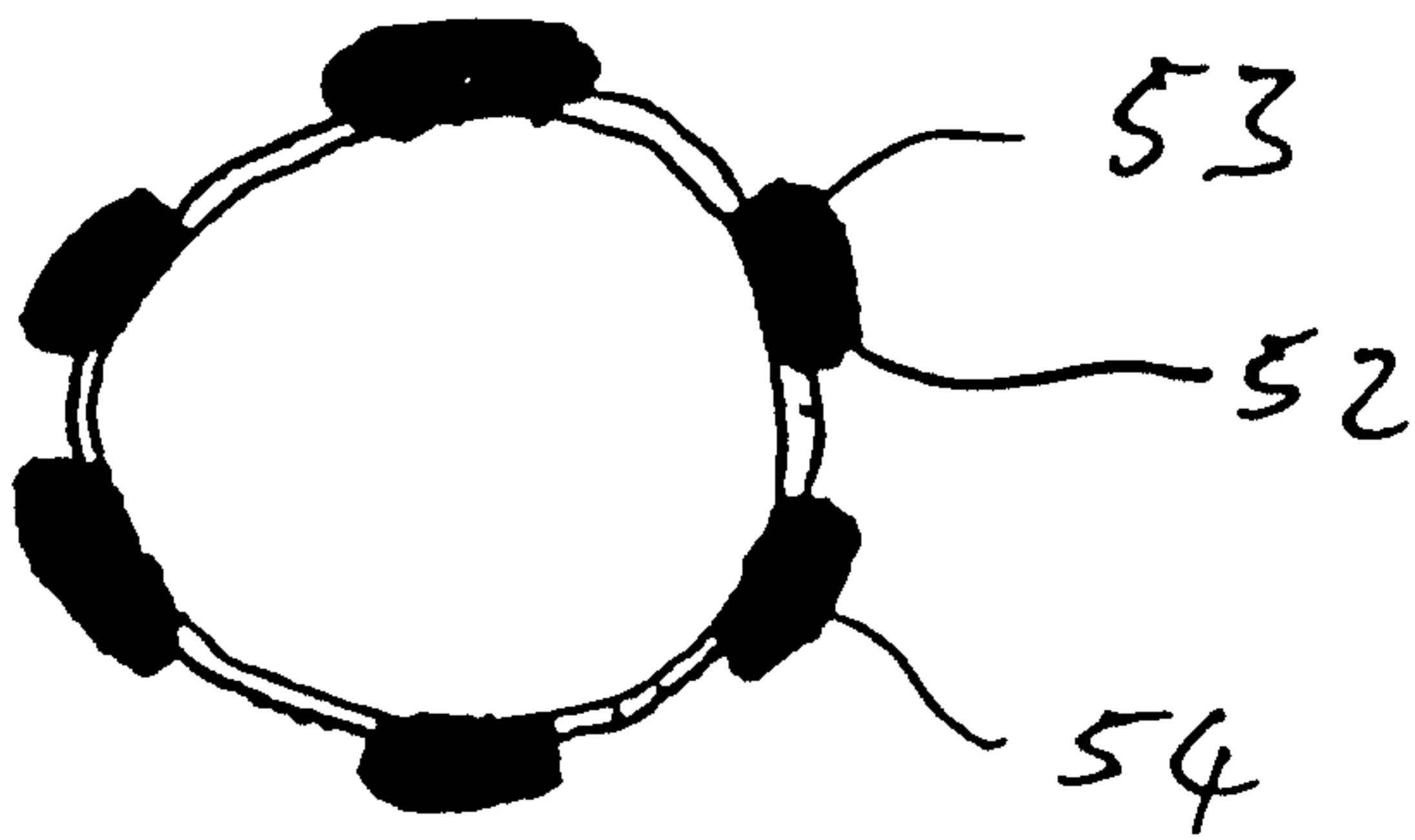

Figure 6

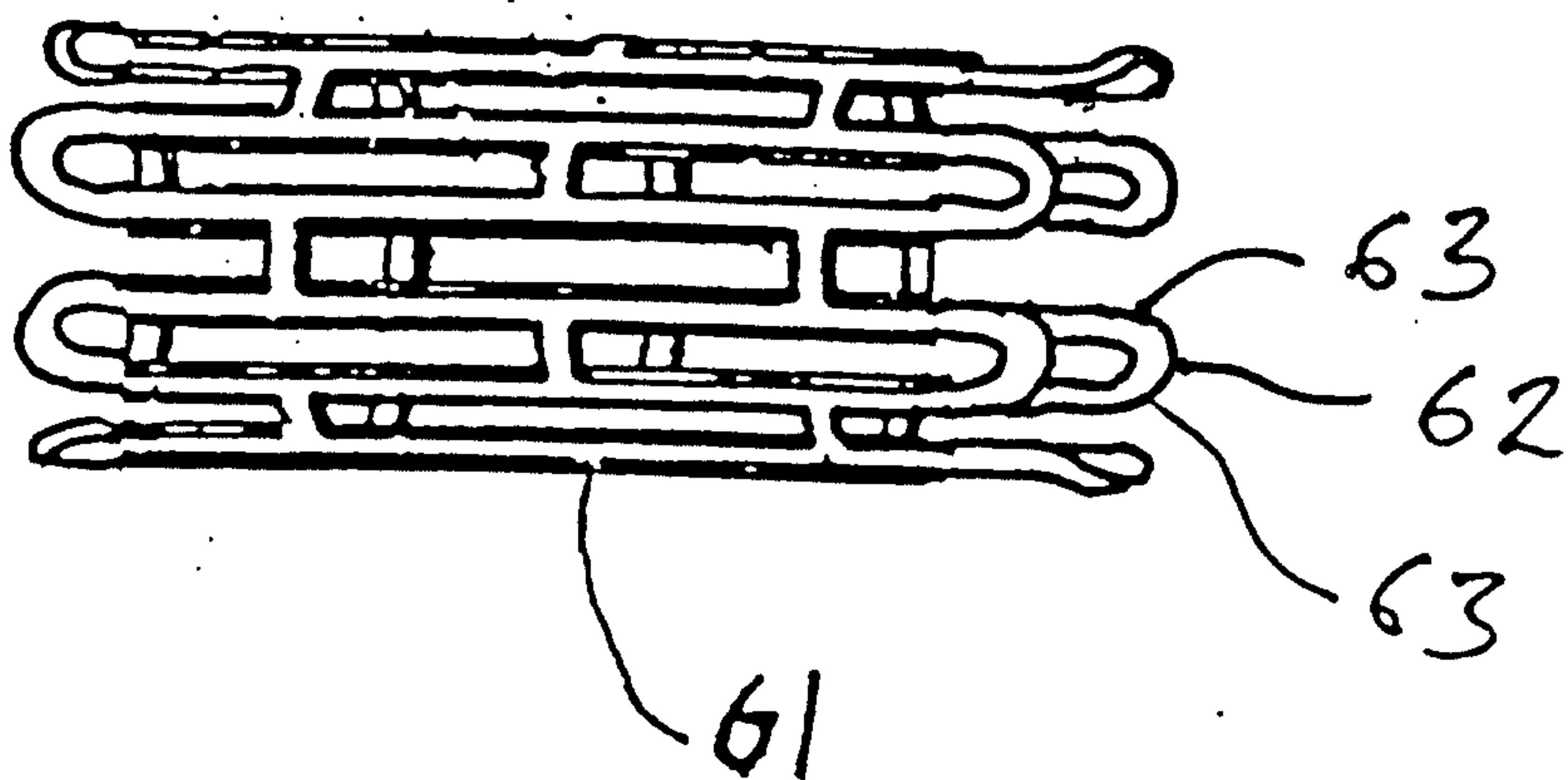

Figure 7A PRIOR ART

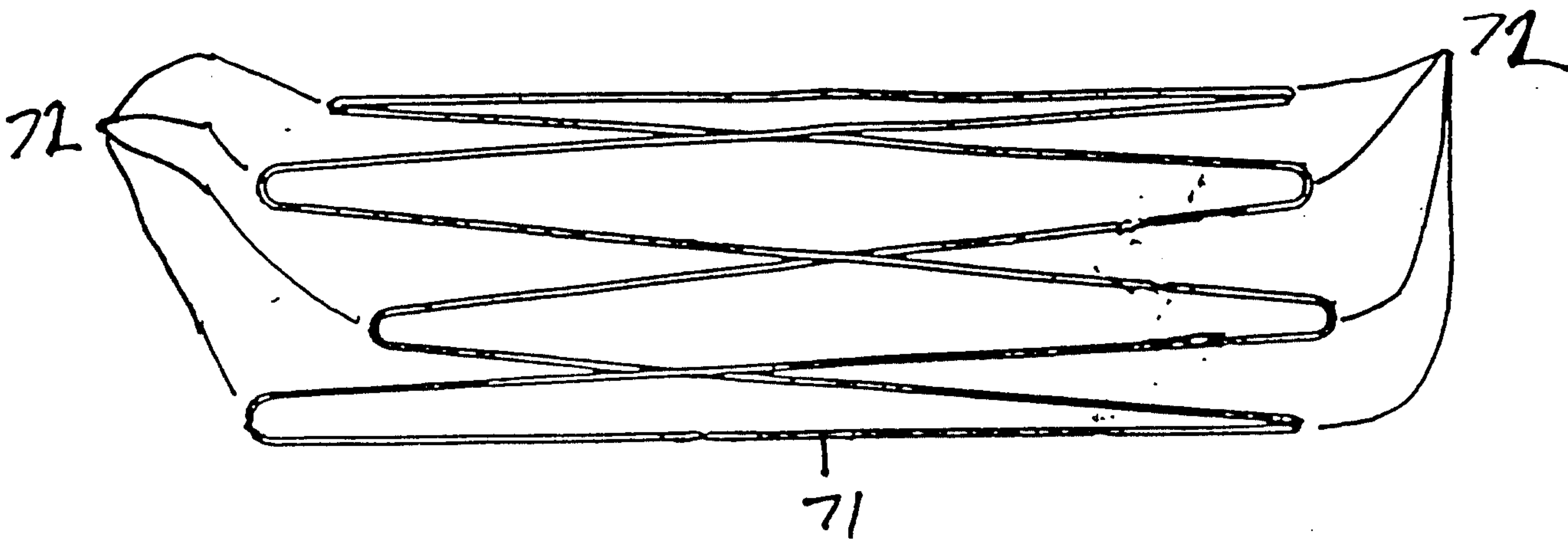

Figure 7B

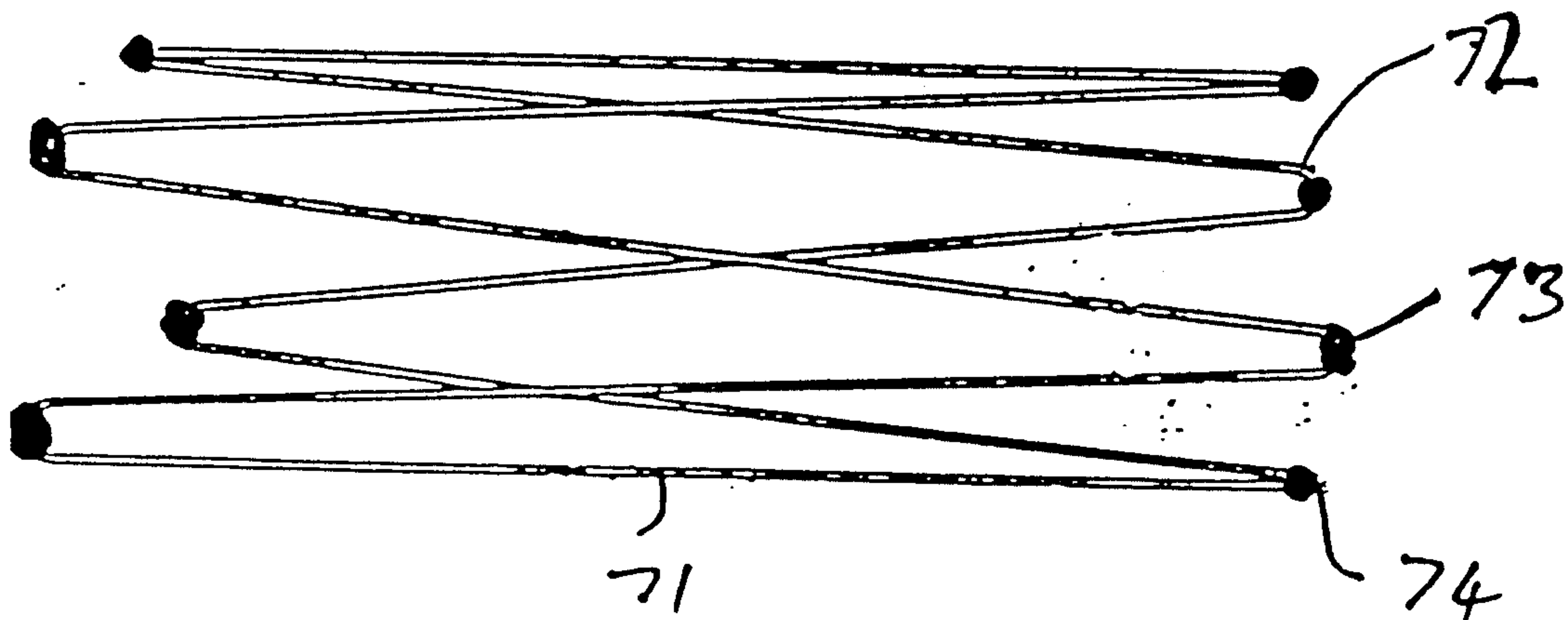
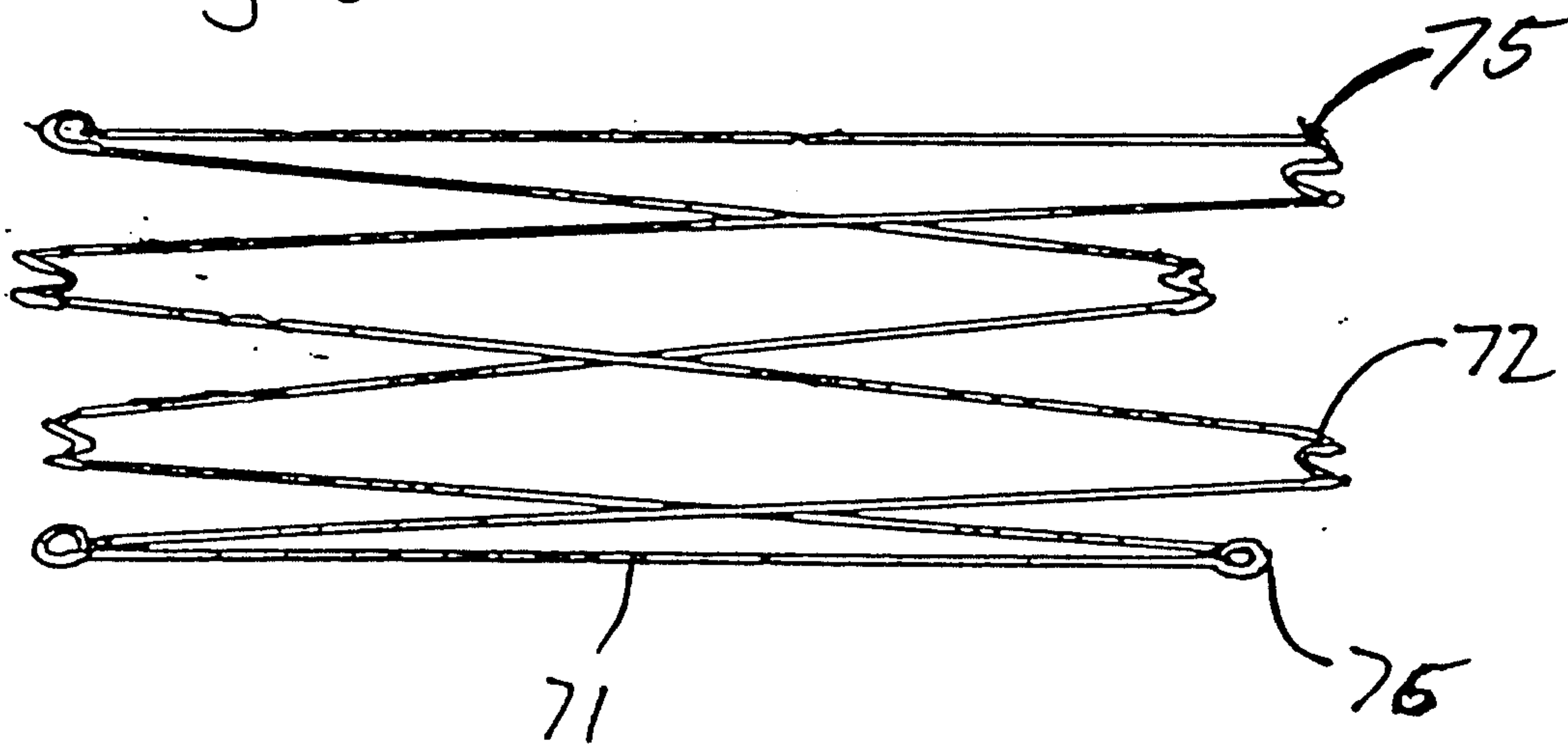

Figure 7C



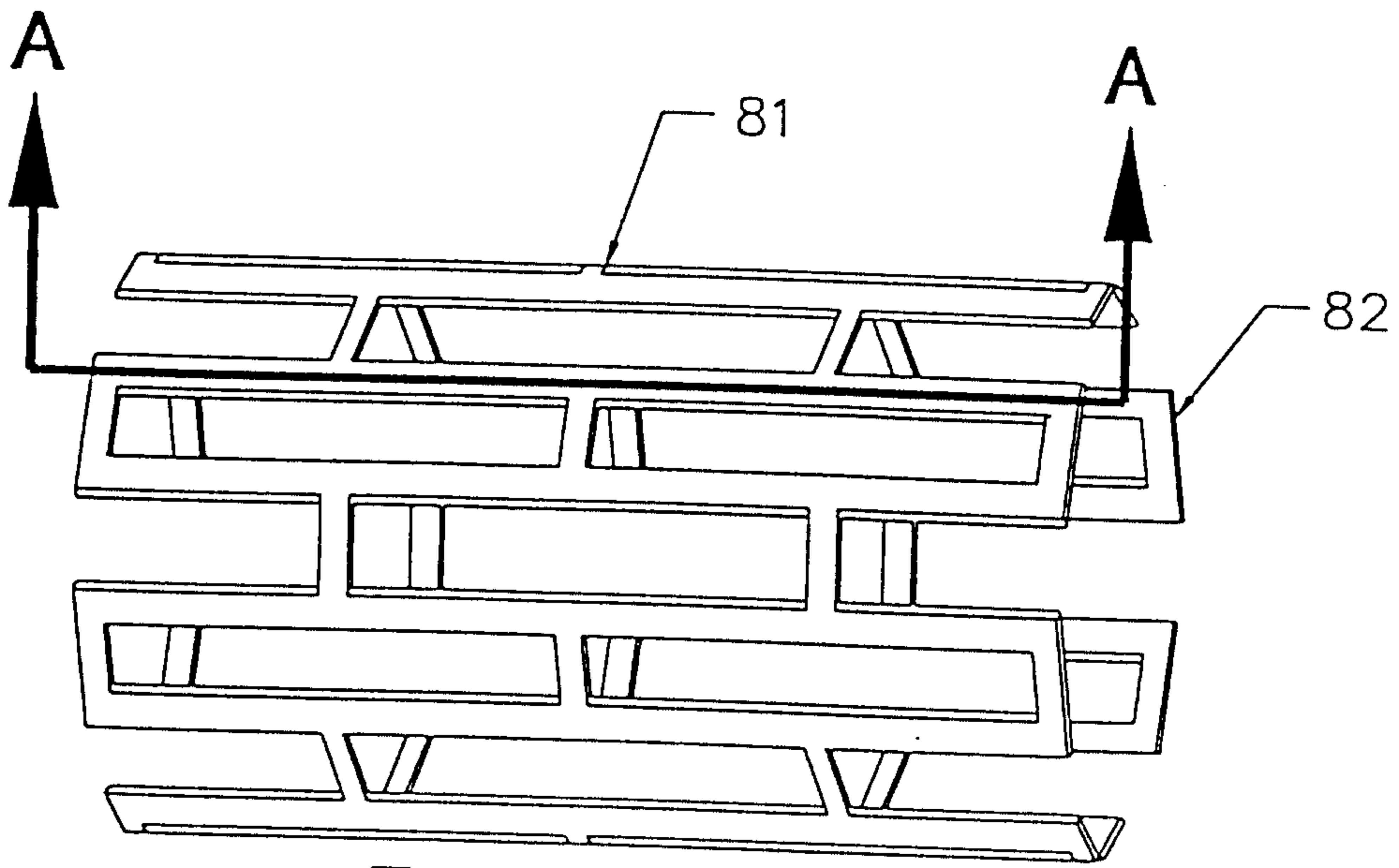

Figure 8A

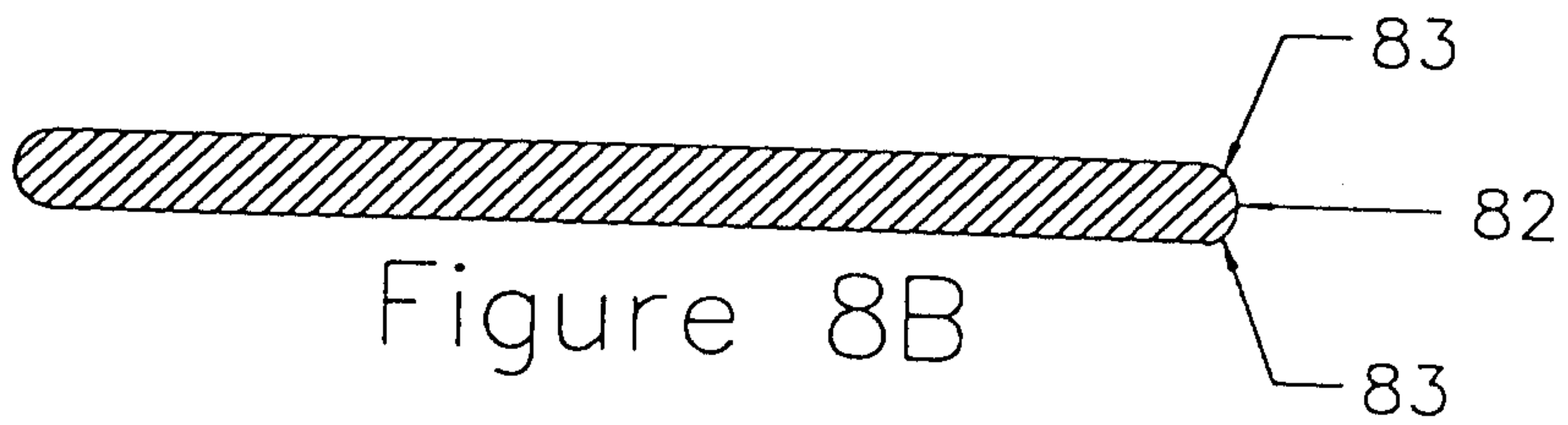

Figure 8B

