

(19) World Intellectual Property Organization  
International Bureau



(43) International Publication Date  
14 February 2008 (14.02.2008)

PCT

(10) International Publication Number  
**WO 2008/018802 A2**

(51) International Patent Classification: Not classified

(74) Agent: ELLIS | VERBOEKET | TERRY; Level 12,  
Forsyth Barr House, Johnston Street, Wellington, 6011  
(NZ).

(21) International Application Number:  
PCT/NZ2007/000165

(81) Designated States (unless otherwise indicated, for every kind of national protection available): AE, AG, AL, AM, AT, AU, AZ, BA, BB, BG, BH, BR, BW, BY, BZ, CA, CH, CN, CO, CR, CU, CZ, DE, DK, DM, DO, DZ, EC, EE, EG, ES, FI, GB, GD, GE, GH, GM, GT, HN, HR, HU, ID, IL, IN, IS, JP, KE, KG, KM, KN, KP, KR, KZ, LA, LC, LK, LR, LS, LT, LU, LY, MA, MD, ME, MG, MK, MN, MW, MX, MY, MZ, NA, NG, NI, NO, NZ, OM, PG, PH, PL, PT, RO, RS, RU, SC, SD, SE, SG, SK, SL, SM, SV, SY, TJ, TM, TN, TR, TT, TZ, UA, UG, US, UZ, VC, VN, ZA, ZM, ZW.

(22) International Filing Date: 25 June 2007 (25.06.2007)

(25) Filing Language: English

(26) Publication Language: English

(30) Priority Data:  
549103 10 August 2006 (10.08.2006) NZ

(71) Applicant (for all designated States except US): EATON POWER QUALITY COMPANY [NZ/NZ]; Eaton Development Centre, 1 Barry Hogan Place, Addington, Christchurch, 8041 (NZ).

(84) Designated States (unless otherwise indicated, for every kind of regional protection available): ARIPO (BW, GH, GM, KE, LS, MW, MZ, NA, SD, SL, SZ, TZ, UG, ZM, ZW), Eurasian (AM, AZ, BY, KG, KZ, MD, RU, TJ, TM), European (AT, BE, BG, CH, CY, CZ, DE, DK, EE, ES, FI, FR, GB, GR, HU, IE, IS, IT, LT, LU, LV, MC, MT, NL, PL, PT, RO, SE, SI, SK, TR), OAPI (BF, BJ, CF, CG, CI, CM, GA, GN, GQ, GW, ML, MR, NE, SN, TD, TG).

(72) Inventor; and  
(75) Inventor/Applicant (for US only): HARRISON, Michael, John [NZ/NZ]; 18 Eskdale Place, Halswell, Christchurch (NZ).

[Continued on next page]

(54) Title: A CYCLO-CONVERTER AND METHODS OF OPERATION

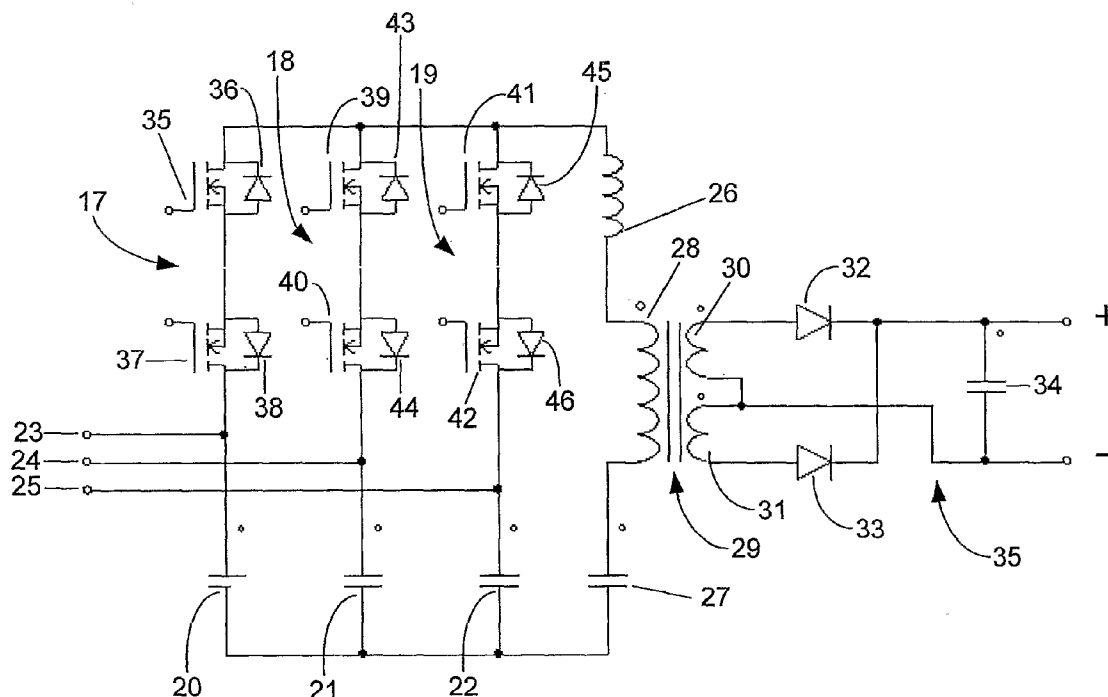

(57) Abstract: A three phase full resonant cyclo-converter suitable for converting a three phase AC supply to a DC output. In one embodiment the cycloconverter controls switching frequency to control converter output and adjusts phase on times for power factor correction. A switching sequence is employed which provides resonant switching to reduce losses and component ratings. The converter provides high conversion efficiency with a simple power component design.

WO 2008/018802 A2



**Published:**

- *without international search report and to be republished upon receipt of that report*

## A CYCLO-CONVERTER AND METHODS OF OPERATION

### FIELD OF THE INVENTION

5 This invention relates to a cyclo-converter and to methods of operating a cyclo-converter. More particularly, although not exclusively, the invention relates to a three phase full resonant cyclo-converter suitable for converting a three phase AC supply to a DC output. Whilst the converter of the present invention may find particular application in telecommunications power supplies it will be appreciated  
10 that it may find application in a wide range of applications.

### BACKGROUND OF THE INVENTION

In applications such as telecommunications power supplies converters must meet  
15 requirements as to Total Harmonic Distortion, harmonic current limits, isolation etc. whilst also achieving high conversion efficiencies. The performance requirements for isolated AC to DC switched mode power supplies for use in telecommunications and large computer applications have to a large extent been met through the adoption of two-stage power supply designs. The first power conversion stage  
20 serves the purpose of achieving Power Factor Correction (PFC) by employing some form of PFC controlled boost converter. Small power supplies tend to use single-phase mains input whereas larger power supplies tend to adopt three-phase mains input and hence need some form of three-phase PFC boost converter (e.g. the Vienna converter). The second power conversion stage serves the purpose of  
25 voltage transformation/isolation and output voltage/current control. This second stage converter usually employs resonant switching techniques in order to maximise conversion efficiency and minimise the size and cooling requirements (hence cost) of the power supply design solution. The problem with two stage cascaded power supplies is that the total conversion losses is the sum total of the  
30 losses of each conversion stage. With each stage achieving typically 96% conversion efficiency a 92% total efficiency typically results.

The promise of high theoretical single stage efficiencies has allured many power supply designers to try to develop effective single stage AC to DC switched mode  
35 power supplies. The energy storage requirements related with single-phase converters has resulted in complex single stage designs with poor overall

conversion efficiencies that lack any practical advantage over the conventional two-stage design approach.

Figure 1 shows a prior art full bridge cyclo-converter consisting of six bidirectional  
5 switches 1 to 6 supplied via three-phase lines 7 to 9 which drives the primary 10  
of an output transformer 11. Switch 1 consists of a forward MOSFET 13 in parallel  
with a body diode 15 in series with a reverse MOSFET 14 in parallel with body  
diode 16. Switches 2 and 3 are of the same configuration. A half bridge rectifier 12  
is provided at the output of the transformer. The cyclo-converter is hard switched  
10 to effect PWM control. To achieve the desired voltage at the output the top and  
bottom switching sequences are offset the required amount. The degree of offset  
determines the period of time the output transformer is shorted and does the period  
of time that currents circulate within the cyclo-converter. This circulated current (as  
opposed to current transferred to the current doubler 12) incurs losses as it passes  
15 through switches 1 to 6. This approach provides an easily controlled converter as  
the output voltage may easily be brought down by adjusting the offset of the upper  
and lower switching. However, this converter requires 12 switching components and  
the hard switching employed requires highly rated components to handle with the  
spikes and losses. Further, such converters typically only have a conversion  
20 efficiency of about 93% and the losses and large number of power components  
makes the converter physically large and expensive to produce.

The publication "A Zero-Voltage Switched, Three-Phase PWM Switching Rectifier  
with Power Factor Correction" from Proceedings of the High-Frequency Power  
25 Conversion Conference: Toronto, Canada; June 9-14, 1991; pp. 252-264 discloses  
a full bridge cyclo-converter in which a switching sequence is employed utilising  
resonant switching in. However, the switching is simple on/off switching and the  
switching sequence is only partially optimised and does not provide full resonant  
switching.

30 Series resonant converters have been provided which employ full resonant  
switching (i.e. the switched currents are near zero at turn off and turn on to effect  
"soft switching" at all switching points). However, such converters include complex  
control circuits and have only switch DC supplies.

35 It would be desirable to provide an isolated converter operable over a wide range of  
input voltages having high conversion efficiency, a low power component count, low

rated power components, no large inductors or storage components and low harmonic distortion

It is an object of the invention to provide a converter satisfying the above  
5 requirements or to at least provide the public with a useful choice.

#### **SUMMARY OF THE INVENTION**

There is provided a cyclo-converter including a resonant circuit in which switching is  
10 determined by resonance of the resonant circuit. This may be implemented as a full resonant three phase half bridge cyclo-converter. Methods of switching the cyclo-converter to control the output of the converter and provide power factor correction are also disclosed. A number of embodiments are described and the following  
15 embodiments are to be read as non-limiting exemplary embodiments only.

According to a first aspect there is provided a three phase half bridge cyclo-converter for driving an inductive load comprising:

- i. three phase inputs
- 20 ii. bidirectional switches between each input and a first output line;
- iii. capacitors between each input and a second output line; and
- iv. a controller controlling the switching of the bidirectional switches on the basis of the output voltage and/or input voltage.

25 According to a further aspect there is provided a three phase half bridge cyclo-converter as claimed in any one of the preceding claims wherein the controller controls the switching frequency of the bidirectional switches in dependence upon the output of the cyclo-converter.

30 According to a further aspect there is provided a full resonant cyclo-converter in which the switches are four mode bidirectional switches having a conducting mode, each having a blocking diode in parallel, wherein for a given cycle the reverse switch is switched in prior to the forward switch to allow natural voltage levels to  
35 facilitate switching.

There is further provided a method of controlling the output of a full resonant cyclo-converter by controlling the switching frequency of the cyclo-converter in dependence upon the difference between a desired output and actual output.

- 5 There is further provided a method of correcting the power factor of a three phase half bridge cyclo-converter by adjusting the proportions of time each phase is switched on.

10 There is further provided a method of controlling the switching of a full resonant cyclo-converter by controlling the main switching sequence of phases in a repeating sequence from the largest to the smallest absolute voltage.

15 There is further provided a of switching a cyclo-converter including a resonant circuit at a switching frequency greater than the supply frequency wherein switching is effected so that the resonant voltage at the switching frequency is utilized to facilitate soft switching of the switches.

20 There is further provided a method of switching a full resonant cyclo-converter wherein the switches are bidirectional switches each consisting of a forward switch and a reverse switch, each having a blocking diode in parallel, the method comprising switching in a blocking switch to allow resonant voltages to facilitate switching of a forward switch.

#### **BRIEF DESCRIPTION OF THE DRAWINGS**

25

The accompanying drawings which are incorporated in and constitute part of the specification, illustrate embodiments of the invention and, together with the general description of the invention given above, and the detailed description of

30

embodiments given below, serve to explain the principles of the invention.

30

Figure 1 shows a prior art cyclo-converter;

Figure 2 shows a half bridge cyclo-converter;

35 Figure 3 shows the voltage waveforms of a three phase AC supply;

- Figure 4 illustrates the switching sequence of the cyclo-converter shown in figure 2;
- 5 Figure 5 illustrates the switching sequence for upper and lower switches of the cyclo-converter;
- Figure 6 illustrates the switching sequence in a three phase waveform;
- Figure 7 illustrates the switching sequence of all switches during normal  
10 switching;
- Figure 8 illustrates the switching sequence of all switches near zero crossings;
- 15 Figure 9 illustrates the switching sequence of all switches near a magnitude crossing of phases;
- Figure 10 shows a transfer function for the series resonant LLC circuit of the cyclo-converter shown in figure 2;
- 20 Figure 11 shows a schematic diagram of a controller for controlling the cyclo-converter shown in figure 2;
- Figure 12 shows an alternative current feedback control circuit;
- 25 Figure 13 shows a first switching element for use in the cyclo-converter shown in figure 2;
- Figure 14 shows a further switching element for use in the cyclo-converter  
30 shown in figure 2;
- Figure 15 shows a further switching element for use in the cyclo-converter shown in figure 2;
- 35 Figure 16 shows a further switching element for use in the cyclo-converter shown in figure 2;

Figure 17 shows a bidirectional half bridge cyclo-converter.

## DESCRIPTION OF EMBODIMENTS OF THE INVENTION

5 Figure 2 shows a half bridge cyclo-converter according to a first embodiment. The cyclo-converter includes bidirectional switches 17 to 19 and capacitors 20 to 22 forming the half bridge. Switch 17 consists of MOSFET 35 in parallel with body diode 36 in series with MOSFET 37 in parallel with body diode 38. Switch 17 has four states:

10

1. on (MOSFETs 35 and MOSFET 37 on);
2. off (MOSFET's 35 and 37 off)
3. forward diode (MOSFET 37 on switching in body diode 36 )
4. reverse diode (MOSFET 35 on switching in body diode 38)

15

Switches 18 and 19 are similarly configured. By utilizing the four switching states full resonant switching can be achieved as will be described.

20 Three phase supply lines 23 to 25 provide a three phase AC supply to the half bridge. The output of the cyclo-converter drives an LLC resonant circuit consisting of inductor 26, capacitor 27 and primary coil 28 of transformer 29. Output coils 30 and 31 are connected via diodes 32 and 33 and capacitor 34 to form half bridge rectifier 35.

25 It will be noted that the circuit is realised with six transistors (compared to 12 for the cyclo-converter shown in Figure 1). Capacitors 20 to 22 form the half-bridge centre point. Inductor 26 and capacitor 27 form the series-resonant circuit. To achieve low load output voltage regulation the resonant circuit can be easily transformed from a simple LC resonant circuit into an LLC resonant circuit by gapping the core  
30 of the main transformer 29. The primary method of output voltage control is achieved by variable frequency control. The use of variable frequency control to a series-resonant converter removes the need for any output inductor (as needed by the PWM controlled cyclo-converter shown in Figure 1).

35 Each of the six transistors is individually controlled. The sequencing order and control of the individual transistors achieves two primary functions:

- A three-voltage level, high frequency waveform is fed into the resonant load to effect a power transfer.
- Transistors that are reverse biased (anti-parallel/body diode conducting) are turned on to create a voltage clamp to limit the voltage stresses incurred during switching transition periods. This clamp action limits the maximum voltage stress to any transistor equal to the peak mains phase to phase voltage.

Figures 3 to 5 illustrate the switching sequence employed to achieve resonant switching. Figure 3 shows the voltage waveforms of the three phases supplied via supply lines 23 to 25 (23 being the blue phase, 24 being the red phase and 25 being the yellow phase). The voltage waveforms are divided into twelve 30° segments between zero crossings and phase magnitude crossings. To enable resonant switching the transistors may be sequenced in the order shown in figure 4 in which the largest absolute voltage magnitude (L) mains phase transistor is switched on first, followed by the mains phase that has the medium absolute voltage magnitude (M), then finally the mains phase with the smallest absolute mains voltage magnitude (S). This sequencing is repeated over each 30° segment (L,M,S,L,M,S,...) with a sub-microsecond dead-time to allow for the resonant load voltage commutation. Since the mains instantaneous input voltages are continually changing the sequencing logic responsible for driving the individual transistors reverses the transistor sequencing order every 30 degrees of mains input. The bottom three rows of the table shown in figure 4 show the required switching sequence that is required to maintain the requirements to achieve resonant (soft) switching. Reading the three phase letters downwards in each column indicates the switching sequence (e.g. Yellow, Blue, Red, Yellow, Blue, Red... for the first sequence etc.). Each 30-degree segment the effective switching order reverses. This reversing order ensures that an "L", "M", "S", "L", "M", "S"... switching order is maintained.

In the table of Figure 4 some of the phase letters (R, Y, B) have a "dash" in front or after the letter. These dashes line up with the same letter, adjacent in the next mains 30-degree segment. These dashes signify how the transition from one segment to the next is achieved. For example consider the transition from segment number 1 to segment number 2 – this transition is synchronised so that it can only occur when the yellow phase switch is turned on (signified by the Y—Y notation).

The switching sequence is shown graphically with respect to the three phases in Figure 6.

5 This resonant switching sequence results in sine-wave current flow through the transistors and output rectifier diodes, such that the current has almost returned to zero when each switching transition occurs. This reduces the switching losses in both the transistors and output diodes and allows for either MOSFET or IGBT switching transistors to be used. If IGBT transistors are used anti-parallel diodes may be employed to allow a reverse current path (emitter to collector).

10

Figure 5 shows a logic table that signifies the function of each of the six transistors of the circuit shown in Figure 2 during each of the 12 mains 30-degree segments where:

15 "L" – The transistor that is controlling the flow of current from the mains phase with the largest absolute voltage magnitude through to the resonant load, transformer, and ultimately the output of the rectifier.

20 "M" – The transistor that is controlling the flow of current from the mains phase with the medium absolute voltage magnitude through to the resonant load, transformer, and ultimately the output of the rectifier.

25 "S" – The transistor that is controlling the flow of current from the mains phase with the smallest absolute voltage magnitude through to the resonant load, transformer, and ultimately the output of the rectifier.

"on" – The transistor that is clamping the voltage created by the resonant load back to the mains phase with the largest absolute voltage magnitude. Note this transistor is turned on for the entire 30-degree mains segment.

30

"m" – The transistor that is clamping the voltage created by the resonant load back to the mains phase with the medium absolute voltage magnitude.

35 "s" – The transistor that is clamping the voltage created by the resonant load back to the mains phase with the smallest absolute voltage magnitude.

Upper case L, M and S indicate the switches that are switched so as to transfer power from supply lines 23 to 25 to the load whereas lower case on, m and s indicate the transistors that are switched to clamp the voltage spikes resulting from switching an inductive load. Over the 3rd segment for example (60° to 90°) with reference to Figures 2,5 and 6 the sequence is:

1. the upper red phase transistor 39 is switched on for the whole segment,
- 10 2. the lower red phase transistor 40 (L) is switched on, supplying current from red phase supply line 24 to transfer power to the load;
3. the lower yellow phase transistor 42 (m) is then switched on allowing diode 45 to clamp the voltage created by the resonant load back to the yellow phase voltage;
- 15 4. just after the lower red phase transistor (L) 40 is switched off the upper yellow phase transistor 41 (M) is switched on to connect yellow phase supply line 25 to transfer power to the load (this is soft resonant switching due to the voltage clamping in step 3 above);
5. shortly after upper yellow phase transistor 41(M) is switched on lower blue phase transistor 37 (s) is switched on to clamp the voltage created by the resonant load back to the blue phase voltage
- 20 6. shortly after upper and lower yellow phase transistors 41 and 42 are switched off lower blue phase transistor 35 (S) is switched on to connect the blue phase supply line 23 to the load.

25

This pattern repeats over each segment with the switching sequence changing for each sequence as shown in figure 5.

In order to achieve the correct mains input current PFC function the S switch on-time approaches a zero value each mains zero crossing as to obtain a correct PFC function the converter needs to be drawing zero current from the S mains phase at the mains voltage zero crossing.

Since it becomes impractical to try and turn a transistor on then off again in an extremely small time period, there comes a point (near each mains voltage zero crossing) where there is no point trying to turn the S transistor on. Hence for a period that starts a few degrees before each mains zero crossing and extends to a

few degrees after the mains zero crossing the cyclo-converter may operate in a two-phase mode. This mode is referred to as a “zero-cross mode” and during this mode of operation the high frequency switching sequence is simply L, M, L, M, L, M,... - were only the L and M transistors are switched on and the S transistor  
5 remains off. During this “zero-cross mode” the transistor on-times for both the L and the M transistor are equal. From a PFC function point of view the mains L phase voltage and the mains M phase voltage are equal (but opposite polarity) at each mains zero voltage crossing, so equal (but opposite) currents need to be drawn from the L and M mains phases. Equal transistor on-times with equal phase  
10 voltages will lead to equal mains currents. The switching sequence for such “zero-cross mode” switching is shown in Figure 8.

A different issue arises in maintaining the normal L, M, S, L, M, S,... high frequency switching sequence at the mains voltage magnitude crossing point. At every mains  
15 magnitude cross point the M and S phase voltages swap over and hence the definitions of M and S must also swap. If the rate of change of the mains phase voltages is considered with respect to the high frequency switching frequency of the cyclo-converter it becomes obvious that the concept of the M and S phase voltages crossing over at a particular instance in time is far from the reality. The rate of  
20 change of the mains phase voltages is so slow that for many high frequency switching cycles the M and the S phase voltages are effectively equal. What’s more, when real world effects like noise are considered it can also be appreciated that the converter may actually operate for several high frequency switching cycles with incorrect M and S definitions. For example, the voltage on the phase we are  
25 calling S is actually greater (by a very small amount) than the voltage on the phase we are calling M. This error in the definition of the M and S phases causes the wrong transistor switching sequence which in turn leads to considerable current flowing from M to S mains phase (or S to M mains phase depending on relative voltage polarities. By changing the high frequency switching sequence used when  
30 the cyclo-converter is operating near to a mains voltage magnitude cross point this problem may be avoided.

For a period that starts a few degrees before each mains magnitude crossing and extends to a few degrees after the mains magnitude crossing the cyclo-converter  
35 may operate in an interleaved mode. This mode is referred to as a “magnitude-cross mode” and during this mode the high frequency switching sequence is simply L, M, L, S, L, M, L, S,... - were the M and S transistors are alternately switched on

between each time the L transistor is switched on. During this “magnitude-cross mode” the transistor on-times for the L, M, and S transistors are all equal. From a PFC function point of view the mains L phase voltage is one polarity and the mains M and S phase voltages are equal to each other (but opposite polarity to the L phase) at each mains magnitude voltage crossing. The current drawn from the mains L phase needs to be returned in equal amounts to the mains M and S phases (e.g. 50:50) this interleaved switching sequence inherently achieves this result. The switching sequence for such “magnitude-cross mode” switching is shown in Figure 9.

10

Thus the cyclo-converter uses three different high frequency switching sequences:

- “zero-cross mode” – used near to mains phase zero crossings
- “Three-phase mode” – the normal mode used the majority of the time
- 15 “magnitude-cross mode” – used near to mains phase magnitude crossings

During the zero-cross mode and the magnitude-cross mode the PFC function is inherent, but during the normal three-phase mode the correct “S/M Ratio” (i.e. the ratio of the time the small phase transistor is on to the ratio of time the medium phase transistor is on) is required to achieve a correct PFC function. The fact that the cyclo-converter achieves inherent PFC control at every mains voltage zero or magnitude cross point, then the mains phase input currents must be exactly correct for 12 points in every mains cycle. Consequently the mains input current PFC function is naturally good despite the “S/M Ratio” control values during the normal three-phase operational mode – hence the “S/M Ratio” can be thought of as a “fine trim” control that can improve the PFC function.

Figure 10 shows the transfer function for the series-resonant LLC converter shown in Figure 2. It can be seen that by varying the operational frequency that the converter is driven at that output voltage may be controlled. It can also be seen that as the converter is loaded up, the output voltage drops (for operation to the right of the peak of each curve). Thus, to maintain a constant output voltage, the operational frequency may be decreased as the output load is increased. Finally it can be seen that the output voltage does not significantly drop as the operational frequency is increased if the converter is lightly loaded. To regulate down the converter output down to achieve low output voltages when the converter is only lightly loaded a “pre-load” across the converter output that can be turned on when

35

the converter is at light load or a discrete inductor may be provided across the transformer primary coil. Another way of improving the no-load regulation ability of a LLC converter is to lower the shunt or magnetising inductance of the main transformer by increasing the transformer gap. This eliminates the need to add an  
5 extra discrete component.

Output voltage control may thus be achieved by controlling the fundamental frequency that the resonant load is switched through the three instantaneous mains input phases voltage states. A voltage feedback loop may control this fundamental  
10 switching frequency, such that above resonance frequency is always maintained. Hence lowering the switching frequency increases the output voltage and increasing the switching frequency reduces the output voltage. Output current limiting may be achieved through an output voltage control loop by reducing the output set-point voltage to reduce or limit the output current.

15 This is a fundamentally different approach to the control of cyclo-converters which have traditionally been controlled by phase shifting the switching sequences of upper and lower switches to achieve PWM control. Whereas traditional cyclo-converters can utilise the "shorted" state to power down the converter pre-loading  
20 may be employed in the converter shown in Figure 2.

Figure 11 shows a schematic diagram of the control logic for the three-phase series-resonant half-bridge cyclo-converter shown in Figure 2. This logic may be implemented in a combination of a Digital Signal Processor (DSP) and  
25 Programmable Logic Array (PLA) device or a number of other technologies. The main output voltage control loop is shown across the top of the diagram. The actual output voltage 47 is compared to a desired "set voltage" 48 by an error amplifier 49. The difference in the output voltage from the set voltage is expressed as an error signal 50 which is then used to drive the switching frequency of the cyclo-converter  
30 to achieve the fundamental variable frequency control as normally employed to control a conventional series-resonant LLC converter.

The error signal 50 is supplied to feedback transfer function block 51. The feedback transfer function block 51 allows the feedback response to be tuned to the  
35 characteristics of the converter in order to achieve minimum output voltage error, stable operation, and quick step response or settling time. Transfer function block

51 would typically contain individual proportional and integral feedback elements similar to any other power supply control loop.

5 The output 52 of the feedback transfer function block 51 feeds a control signal into a variable frequency oscillator 53 such that the "clock frequency" control signal that feeds the gate drive control logic 54 can effect the switching frequency of the cyclo-converter according to the output voltage feedback error signal 47 to drive the six power switches via drive signals 55 to 60.

10 Current amplifier 61 monitors the cyclo-converter's output current 62 and compares it to the output current limit 63. If the output current 62 is less than the output current limit 63 then the current amplifier 61 has no effect on the control of cyclo-converter. Should the output current 62 exceed the output current limit 61 then the current amplifier 61 will take over control of the primary (output voltage) control loop  
15 by pulling down error signal 50, thus reducing the output voltage in order to limit the output current to the current limit value.

Mains input Power Factor Correction (PFC) control may be achieved by varying the on time of each of the three mains input voltages. The output voltage feedback  
20 control loop sets the fundamental switching frequency – e.g. the total cycle time period. By increasing or decreasing the time that a particular transistor is switched on the current that is drawn from that particular phase can be controlled. Adjusting the proportions of time between the three phases will also adjust the voltage fed to the resonant load and hence the output voltage, but this effect is continually  
25 compensated by the output voltage control loop. Determining the specific required transistor on-times for each of the three input voltage states (to achieve PFC control) can be achieved either through characterising the requirements for all possible operating conditions or through an active control circuit that monitors the instantaneous individual mains currents then adjusts the respective transistor on-  
30 times to achieve the correct mains current draw. The instantaneous individual mains currents can be simply obtained by de-multiplexing the resonant load current into three components according to the current state of the switching transistors.

Preferably the phase having the largest absolute voltage (L) is switched on for a  
35 constant period, preferably about half the total switching period. The remaining portion is preferably divided between the phases having the middle absolute voltage (M) and the lowest absolute voltage (S). To effect PFC the DC output voltage and

current 65 and three phase input voltages 66 may be input to a lookup table 64 to develop a control signal 67 "S/M Ratio" which is fed into the gate drive control logic block 54. The "S/M Ratio" control signal allows the ratio of the respective "Small" to "Medium" transistor on-times. Varying the "S/M Ratio" is the primary method of  
5 determining the respective current path for the return current drawn from the "Large" mains phase. If the "S/M Ratio" is set to zero (e.g.  $S=0$ ) then all the current that is drawn from the "Large" mains phase is returned to the "Medium" mains phase. If the "S/M Ratio" is set to infinity (e.g.  $M=0$ ) then all the current that is drawn from the "Large" mains phase is returned to the "Small" mains phase.

10

The values entered into the look-up table may be determined by operating the cyclo-converter at a specific operating condition and then tuning the table values to obtain the lowest mains current Total Harmonic Distortion (THD) or based on modelling. The "S/M Ratio" is varied throughout the 360 degree mains cycle, hence  
15 the mains current profile can be accurately manipulated (effectively each mains degree – or finer resolution if deemed necessary). By repeatable tuning the "S/M Ratio" values at different operational conditions the look-up table can allow for the entire operational spectrum for the cyclo-converter to be mapped out. The use of this look-up table avoids the need to actually monitor the input mains currents in  
20 production built cyclo-converters, hence simplifying the implementation of control hardware.

The "gate drive control logic" 54 has three fundamental inputs:

- 25
- Clock Frequency 68 – primary parameter for output voltage control
  - S/M Ratio 67 – primary parameter for mains input current THD control
  - Mains Input Voltage 66 (x3) – used to determine "Mains Angle"

Combinational and sequential logic implemented within a Programmable Logic  
30 Array (PLA) may use the "Mains Angle" information to determine the individual phase voltage magnitudes and polarities and accordingly determines which transistors should be driven with which of the six control signals: "L", "M", "S", "on", "m", & "s". The "Clock Frequency" 68 & "S/M Ratio" 67 control signals are combined with the "Mains Angle" 66 information to determine the specific high  
35 frequency drive signal for each of the six main transistors.

Determining the specific required transistor on-times for each of the three input voltage states (to achieve PFC control) can also be achieved by an active control circuit that monitors the instantaneous individual mains currents and then adjusts the respective transistor on-times to achieve the correct mains current draw. The  
5 instantaneous individual mains currents can be obtained by de-multiplexing the resonant load current into three components according to the current state of the switching transistors.

The current de-multiplexer circuit of Figure 12 shows how the three individual mains  
10 currents can be extracted from the cyclo-converter main transformer primary current. The current sensor 69 and amplifier 70 monitors the cyclo-converter main transformer primary current. The three de-multiplexer switches 71, 72 and 73 are closed (one at a time) according to which of the three mains AC switches (back-to-back transistors) is conducting current in the cyclo-converter. The de-multiplexed  
15 signal is then low pass filtered by filters 74, 75 and 76 to remove the high frequency switching noise, resulting in three unique signals that represent the cyclo-converter mains input currents. This circuit could be used to implement mains input current THD control from a feedback driven control loop instead of using the look-up table concept described above. Alternatively three individual mains current sensors  
20 could be used instead of this de-multiplexer circuit to achieve the same result.

Figures 13 to 16 show possible bidirectional switches that may be used in the cyclo-converter shown in Figure 2

25 Figure 13 shows a switch consisting of two back-to-back MOSFET transistors 77 and 78. One MOSFET blocks the forward current and the other blocks the reverse current path. The body diodes 79 and 80 of each MOSFET provides a current path for the other MOSFET.

30 Figure 14 shows a switch consisting of two back-to-back IGBT transistors 81 and 82. Since IGBT devices do not exhibit an inherent body diode a separate discrete diode 83, 84 referred to as an "anti-parallel" diode is connected across the emitter and collector terminals of the transistor. This anti-parallel diode serves the same function in the AC switch as the body diode in the MOSFET AC switch.

35

Figure 15 shows a switch consisting of two MOSFET transistors 85 and 86 but uses two extra discrete diodes 87 and 88 in order to deactivate the body diode of the MOSFET. This circuit can be used to allow the use of MOSFET transistors that exhibit extremely slow performance from the body diode. The discrete diodes would typically be an ultra-fast device and this AC switch will exhibit a diode recovery time that is determined by the discrete diodes performance (as opposed to the MOSFET body diode recovery performance).

Figure 16 shows a switch employing a back-to-back combination of both MOSFETs 89 and 90 and IGBT devices 91 and 92. This combination can deliver the best characteristics of both devices. This combination can provide the low conduction losses that IGBT transistors provide and the low switching losses that MOSFET transistors provide.

Any of the switches shown in Figures 13 to 16 could be used in the three-phase series-resonant half-bridge cyclo-converter shown in Figure 2. The options offer differences in cost and performance.

Figure 17 shows a variant of the cyclo-converter shown in Figure 2 in which MOSFETs 93 and 94 replace diodes 32 and 33 to provide synchronous rectification. MOSFETs 93 and 94 include inherent body diodes shown in parallel with each MOSFET. The application of synchronous rectification may increase the overall conversion efficiency from 96% to 97% (400V AC input 48 V DC output) – i.e. a reduction of total conversion losses of 25% or in other words a reduction in output rectification losses of 50%. This level of efficiency gain can justify the extra cost and control complexity of changing from diode to synchronous rectification for the output devices.

A by-product of changing the output diodes to controlled MOSFET devices to achieve synchronous rectification is that the converter becomes bi-directional (for energy flow). With appropriate control this three-phase AC to DC converter (rectifier) can be used to perform the function of a DC to three-phase AC converter (inverter). This will allow the converter to be used in UPS type applications.

There is thus provided a single stage frequency controlled full resonant converter including power factor correction. The control approach is quite different to prior art

approaches in which the switching of upper and lower switches is shifted to short the load to power down the converter. The above converter utilises switching frequency control via a feedback loop to control converter output and adjustment of phase on times to provide power factor correction. With full resonant operation  
5 lower rated semiconductor components may be used.

The converter provides a simple power component design with a greatly reduced power component count. The single stage configuration provides high conversion efficiency and simplifies the design. The design also avoids the need for large  
10 energy storage devices or large output inductors due to the comparatively high switching frequency. The DC output is fully isolated from the input source. Output voltage control (via switching frequency) is isolated from PFC by adjusting the on times for each phase. The converter also achieves low total harmonic distortion. The converter may be used over a wide range of input voltages and can supply a  
15 wide range of output voltages.

While the present invention has been illustrated by the description of the embodiments thereof, and while the embodiments have been described in detail, it is not the intention to restrict or in any way limit the scope of the appended claims to  
20 such detail. Additional advantages and modifications will readily appear to those skilled in the art. Therefore, the invention in its broader aspects is not limited to the specific details, representative apparatus and method, and illustrative examples shown and described. Accordingly, departures may be made from such details without departure from the spirit or scope of the Applicant's general inventive  
25 concept.

**CLAIMS**

1. A three phase half bridge cyclo-converter for driving an inductive load comprising:
- 5           i. three phase inputs
- ii. bidirectional switches between each input and a first output line;
- iii. capacitors between each input and a second output line; and
- iv. a controller controlling the switching of the bidirectional switches on the basis of the output voltage and/or input voltage.
- 10
2. A three phase half bridge cyclo-converter as claimed in claim 1 including a resonant circuit connected across the output lines.
3. A three phase half bridge cyclo-converter as claimed in claim 1 or claim 2
- 15           wherein the resonant circuit includes a primary coil of a transformer and a capacitor.
4. A three phase half bridge cyclo-converter as claimed in claim 3 wherein the resonant circuit includes an additional inductive element.
- 20
5. A three phase half bridge cyclo-converter as claimed in claim 4 wherein the additional inductive element is provided by gapping the transformer.
6. A three phase half bridge cyclo-converter as claimed in any one of the
- 25           preceding claims wherein the bidirectional switches can switch on or off or switch in a diode of either polarity.
7. A three phase half bridge cyclo-converter as claimed in claim 6 wherein each bidirectional switch consists of back to back MOSFET transistors, each
- 30           having a body diode in parallel.
8. A three phase half bridge cyclo-converter as claimed in claim 6 wherein each bidirectional switch consists of back to back IGBT devices with anti-parallel diodes in parallel.
- 35

9. A three phase half bridge cyclo-converter as claimed in claim 6 wherein each bidirectional switch consists of MOSFET transistors in parallel with diodes in parallel with each transistor and in series with each transistor.
- 5 10. A three phase half bridge cyclo-converter as claimed in claim 6 wherein each bidirectional switch consists of a back to back configuration of a MOSFET and IGBT transistor in parallel.
- 10 11. A three phase half bridge cyclo-converter as claimed in any one of the preceding claims wherein the controller controls the switching frequency of the bidirectional switches in dependence upon the output of the cyclo-converter.
- 15 12. A three phase half bridge cyclo-converter as claimed in claim 11 wherein the controller controls the switching frequency of the bidirectional switches in dependence upon the output voltage of the cyclo-converter.
- 20 13. A three phase half bridge cyclo-converter as claimed in claim 11 or claim 12 wherein the switching frequency is controlled in dependence on a resonant transfer function for the resonant components.
- 25 14. A three phase half bridge cyclo-converter as claimed in any one of the preceding claims wherein the controller reduces the output of the converter when the output current exceeds a threshold.
- 30 15. A three phase half bridge cyclo-converter as claimed in any one of the preceding claims wherein the controller achieves power factor correction by adjusting the period of time each phased is switched on for.
- 35 16. A three phase half bridge cyclo-converter as claimed in any one of the preceding claims wherein the controller achieves power factor correction by adjusting the ratio of time two phases are switched on.
17. A three phase half bridge cyclo-converter as claimed in claim 16 wherein the phase with the largest absolute voltage is switched on for a constant time.

18. A three phase half bridge cyclo-converter as claimed in claim 16 wherein the phase with the largest absolute voltage is switched on for about half the time.
- 5 19. A three phase half bridge cyclo-converter as claimed in any one of claims 16 to 18 wherein the switching ratio is determined by the controller based upon the input and output waveforms.
- 10 20. A three phase half bridge cyclo-converter as claimed in any one of claims 16 to 18 wherein the controller includes a look up table to calculate the switching ratios.
- 15 21. A three phase half bridge cyclo-converter as claimed in any one of the preceding claims wherein the controller controls switching of the bidirectional switches to predominantly switch in the order of the phase having the greatest absolute voltage, followed by the phase having the middle absolute voltage followed by the phase having the lowest absolute voltage.
- 20 22. A three phase half bridge cyclo-converter as claimed in claim 21 wherein near a zero crossing of a phase only the other two phases are switched.
- 25 23. A three phase half bridge cyclo-converter as claimed in claim 21 wherein near magnitude crossings of two phases the other phase is switched alternately with those phases.
- 30 24. A three phase half bridge cyclo-converter as claimed in claim 21 wherein elements of the bidirectional switches are preswitched by the controller to ensure soft switching.
- 35 25. A three phase half bridge cyclo-converter as claimed in any one of the preceding claims including an output rectifier.
26. A three phase half bridge cyclo-converter as claimed in claim 25 wherein the output rectifier includes bidirectional switching elements enabling the converter to function as an inverter.

27. A three phase half bridge cyclo-converter as claimed in claim 1 wherein the the controller adjusts the period of time each phase is switched on to control converter output.
- 5 28. A three phase half bridge cyclo-converter as claimed in claim 27 wherein the controller varies the ratios of time each phase is switched on to control power factor.
- 10 29. A three phase half bridge cyclo-converter as claimed in claim 27 or claim 28 wherein the timings are obtained from a lookup table based on cyclo-converter output and input waveforms.
- 15 30. A full resonant cyclo-converter in which the switches are four mode bidirectional switches having a conducting mode, each having a blocking diode in parallel, wherein for a given cycle the reverse switch is switched in prior to the forward switch to allow natural voltage levels to facilitate switching.
- 20 31. A three phase half bridge cyclo-converter.
32. A cyclo-converter including a resonant circuit in which switching is determined by resonance of the resonant circuit.
- 25 33. A full resonant three phase half bridge cyclo-converter.
34. A method of controlling the output of a full resonant cyclo-converter by controlling the switching frequency of the cyclo-converter in dependence upon the difference between a desired output and actual output.
- 30 35. A method as claimed in claim 34 wherein the output is voltage.
36. A method as claimed in claim 34 wherein the output is current.
37. A method as claimed in claim 34 wherein the output is power.
- 35 38. A method of correcting the power factor of a three phase half bridge cyclo-converter by adjusting the proportions of time each phase is switched on.

39. A method as claimed in claim 38 wherein one phase is switched on for a fixed period of time.
- 5 40. A method as claimed in claim 39 wherein the one phase is the phase having the greatest absolute voltage.
41. A method as claimed in claim 39 or claim 40 wherein the one phase is switched on for the longest period of time.
- 10 42. A method as claimed in claim 39 or claim 40 wherein the one phase is switched on for about half the time.
43. A method as claimed in any one of claims 39 to 42 wherein the other two phases are switched on for about half the time.
- 15 44. A method as claimed in any one of claims 39 to 42 wherein the ratio of time the other two phases are switched on is varied to control power factor.
- 20 45. A method of controlling the switching of a full resonant cyclo-converter by controlling the main switching sequence of phases in a repeating sequence from the largest to the smallest absolute voltage.
46. A method as claimed in claim 45 wherein near phase magnitude crossings the crossing phases are switched alternately between the phase having the largest absolute voltage and the crossing phases.
- 25 47. A method as claimed in claim 46 wherein the crossing phases are switched alternately with the phase having the largest absolute voltage.
- 30 48. A method as claimed in any one of claims 45 to 47 wherein near a phase zero crossings only the other two phases are switched.
- 35 49. A method of switching a cyclo-converter including a resonant circuit at a switching frequency greater than the supply frequency wherein switching is effected so that the resonant voltage at the switching frequency is utilized to facilitate soft switching of the switches.

50. A method of switching a full resonant cyclo-converter wherein the switches are bidirectional switches each consisting of a forward switch and a reverse switch, each having a blocking diode in parallel, the method comprising
- 5 switching in a blocking switch to allow resonant voltages to facilitate switching of a forward switch.

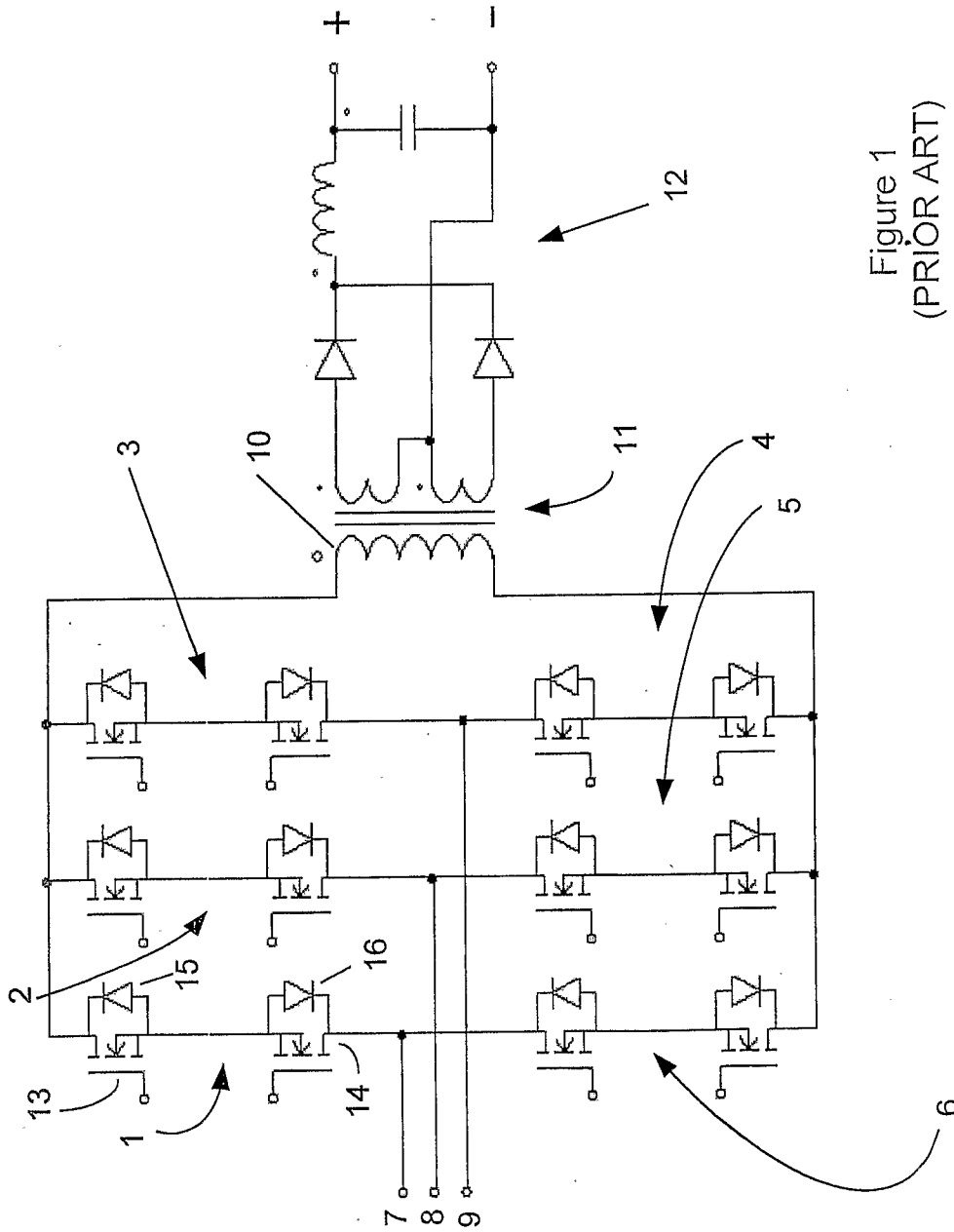

Figure 1  
(PRIOR ART)

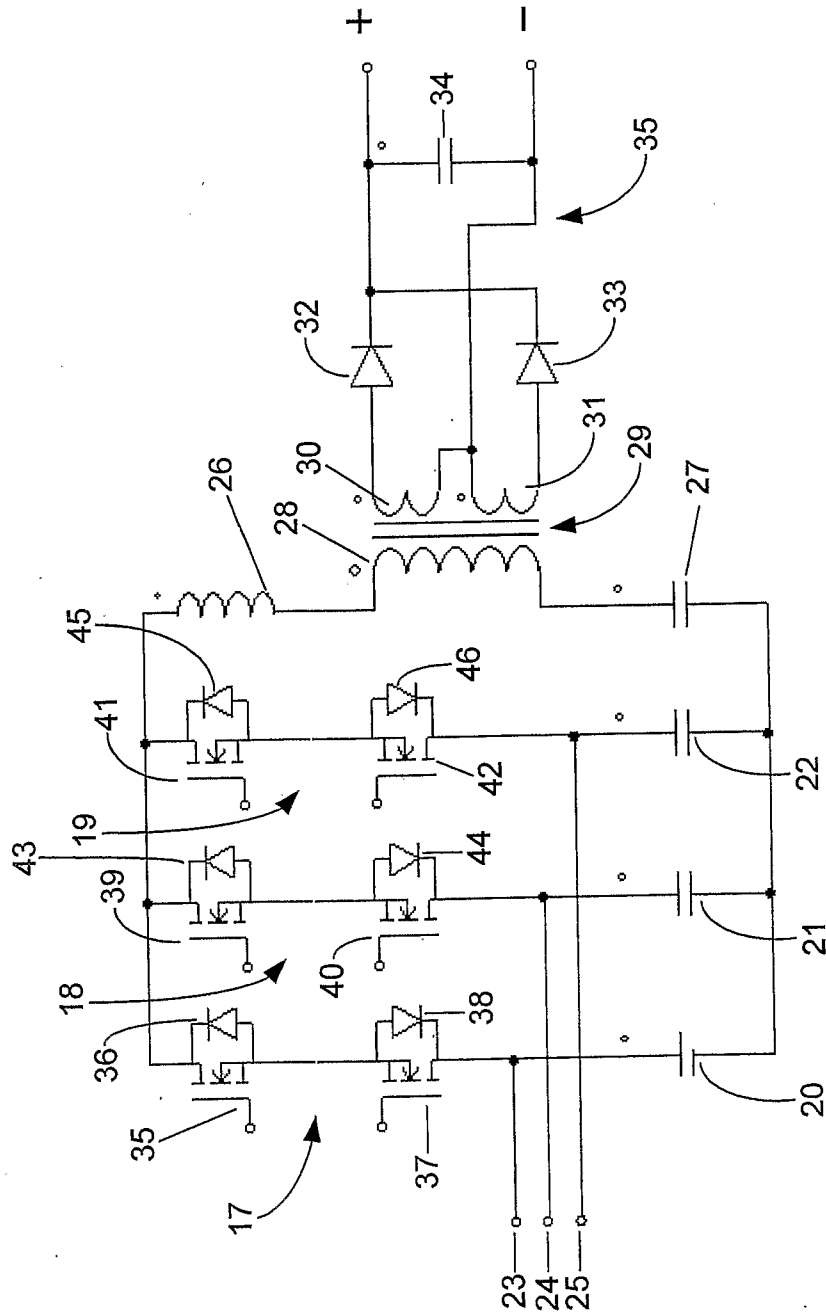

Figure 2

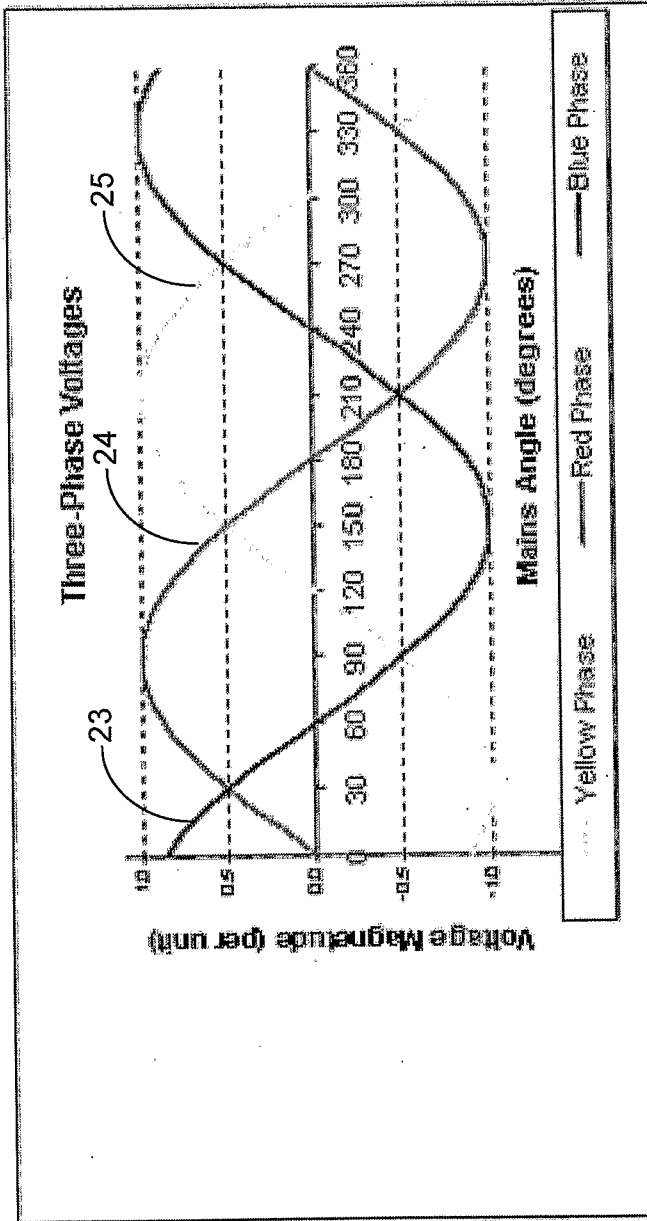

Figure 3

Mains Start Angle	0	30	60	90	120	150	180	210	240	270	300	330
Mains Finish Angle	30	60	90	120	150	180	210	240	270	300	330	360
Sequence Segment	1	2	3	4	5	6	7	8	9	10	11	12
L			B		R				B		R	
M	B	R	R	R		R	B	R	R	R		R
S	R	B		B	B	B	R	B		B	B	B

Figure 4

Mains Start Angle	0	30	60	90	120	150	180	210	240	270	300	330
Mains Finish Angle	30	60	90	120	150	180	210	240	270	300	330	360
Sequence Segment	1	2	3	4	5	6	7	8	9	10	11	12
Red Upper	S	M	L	L	M	S	S	M	L	L	M	S
Red Lower	S	M	L	L	M	S	S	M	L	L	M	S
Yellow Upper	L	L	M	S	S	m	on	on	m	s	S	M
Yellow Lower	on	on	m	s	S	M	L	L	M	S	s	m

Figure 5

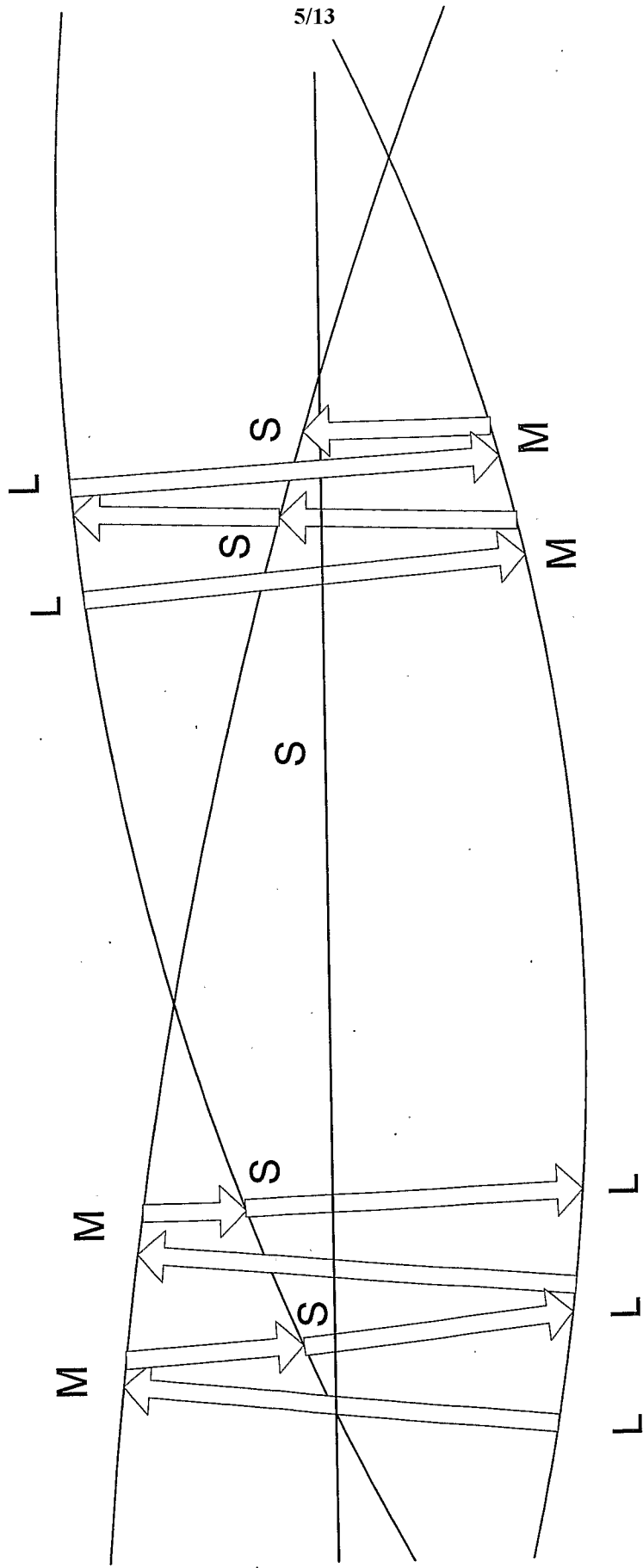

Figure 6

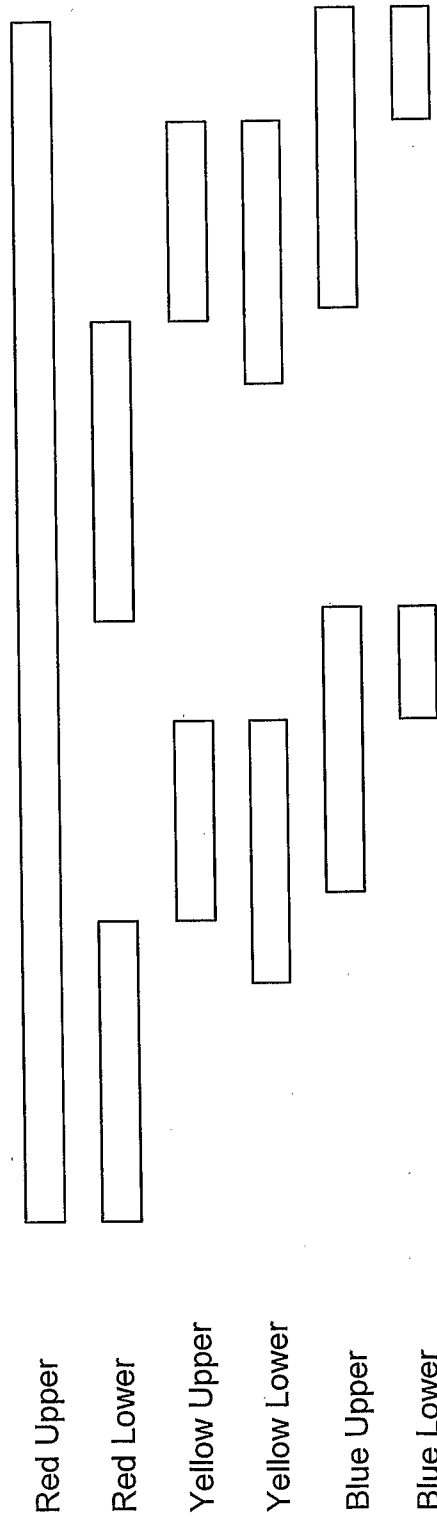

Figure 7

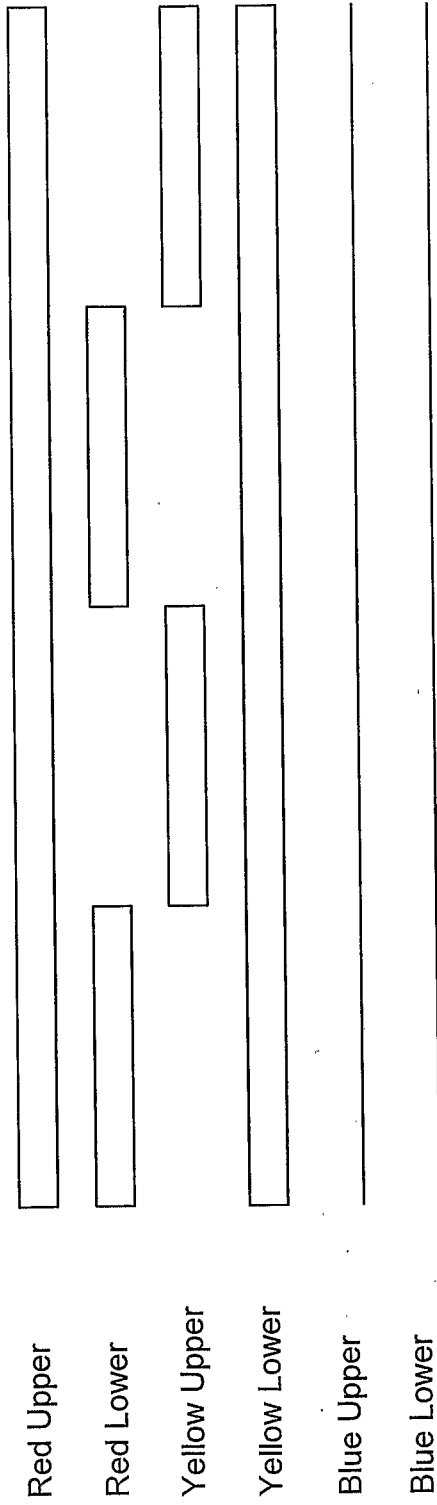

Figure 8

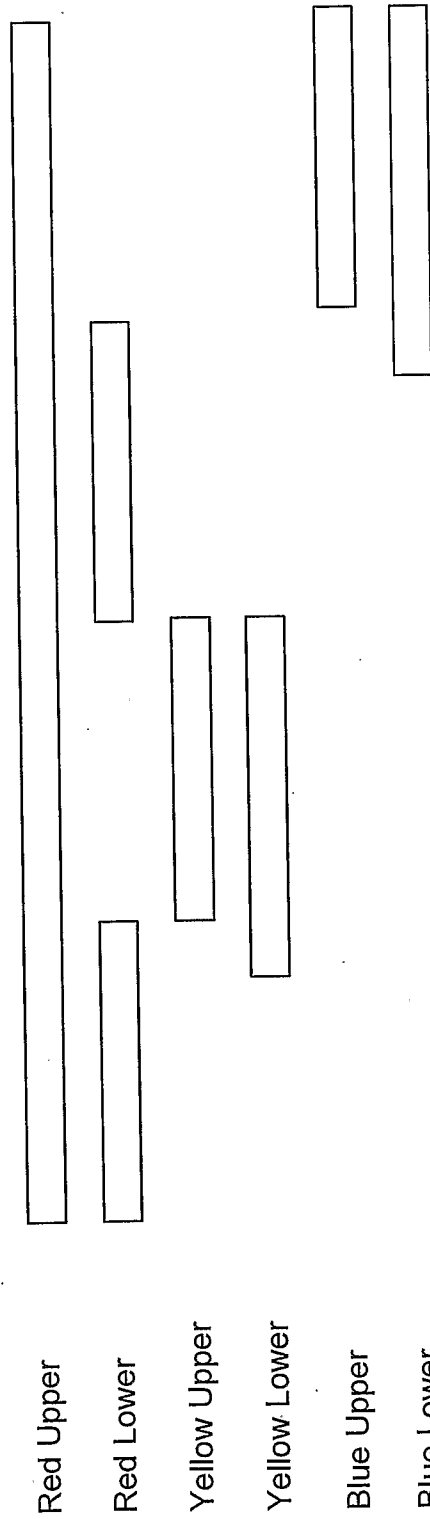

Figure 9

Series Resonant LLC Transfer Function

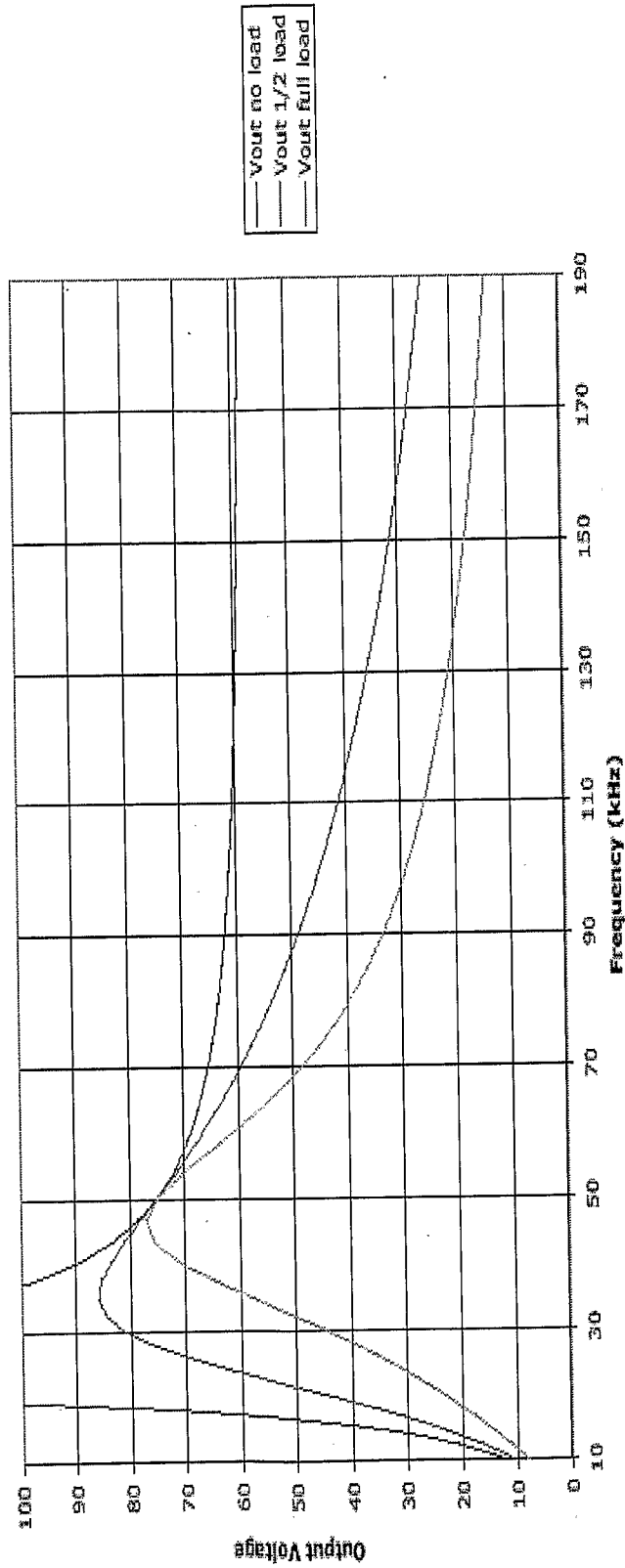

Figure 10

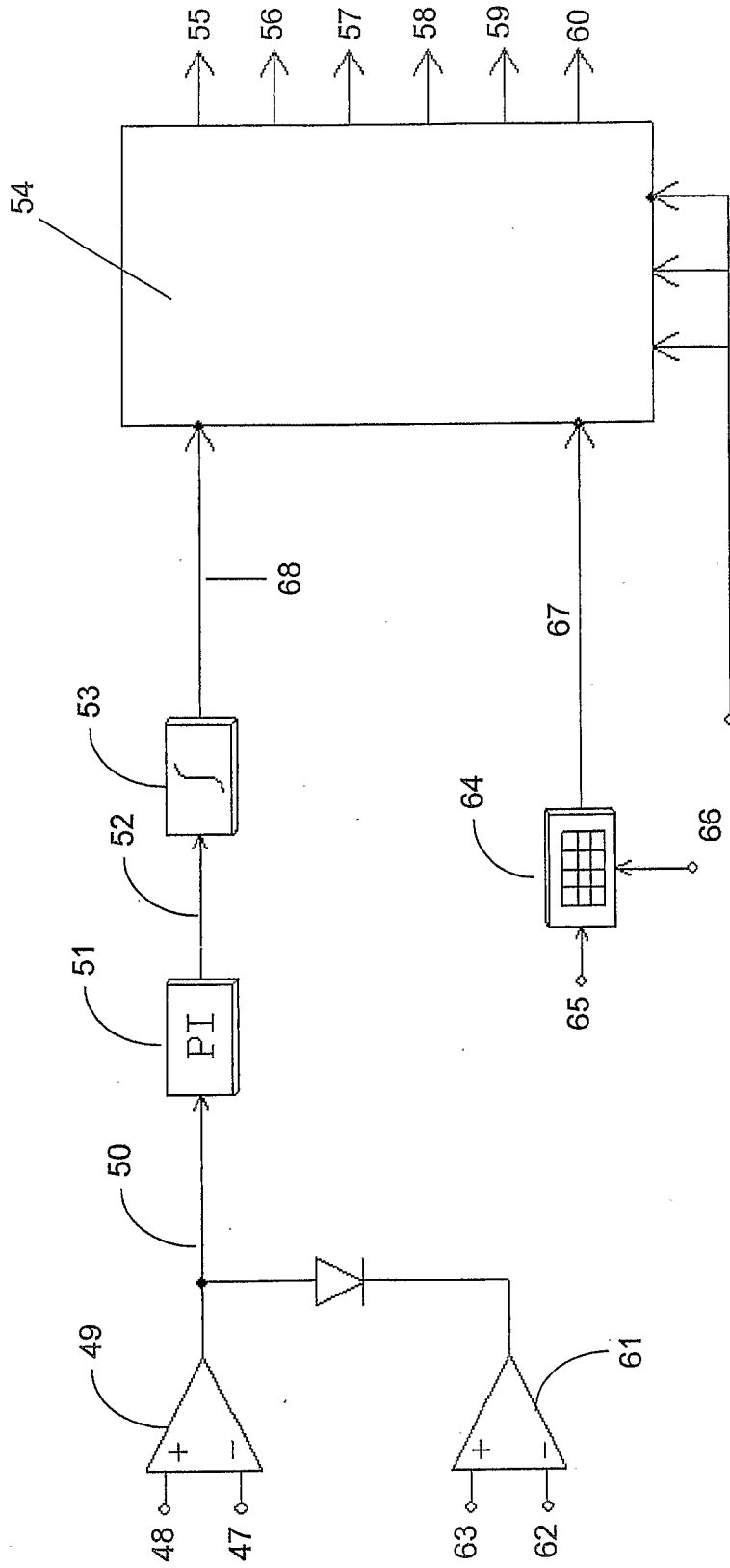

Figure 11

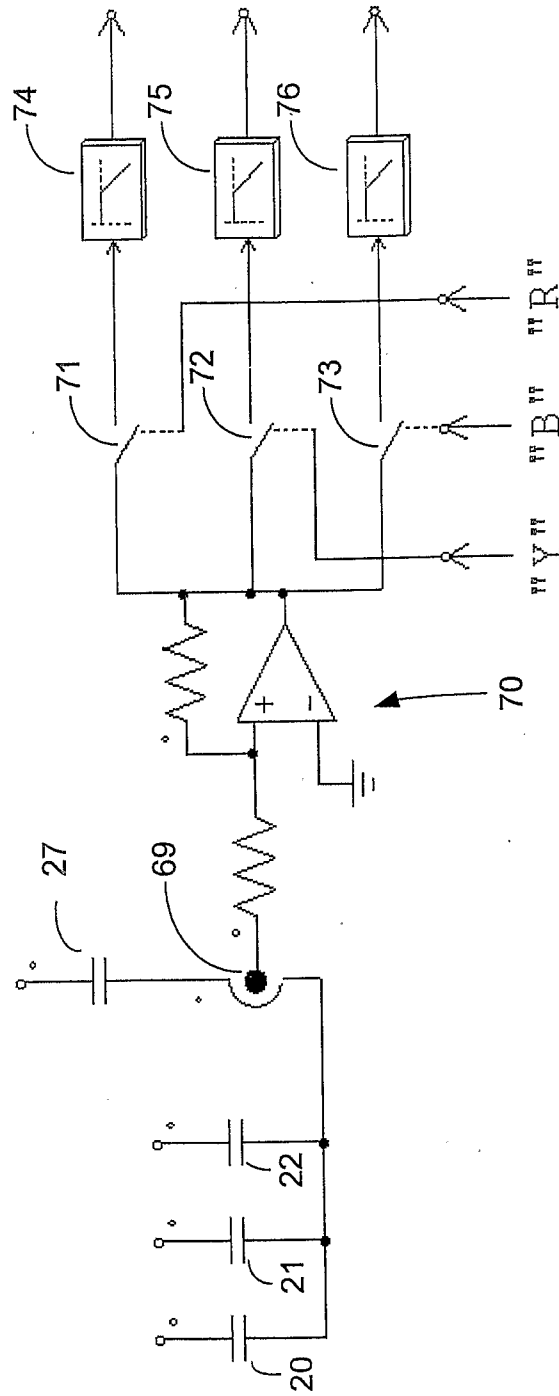

Figure 12

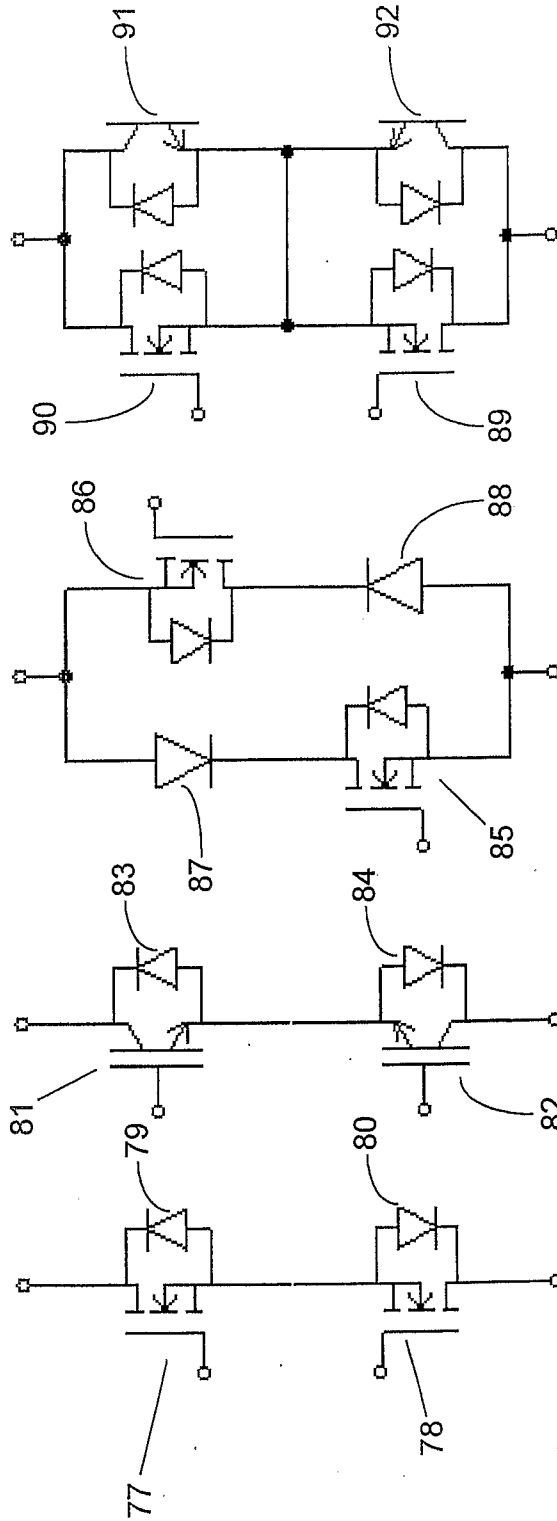

Figure 16

Figure 15

Figure 14

Figure 13

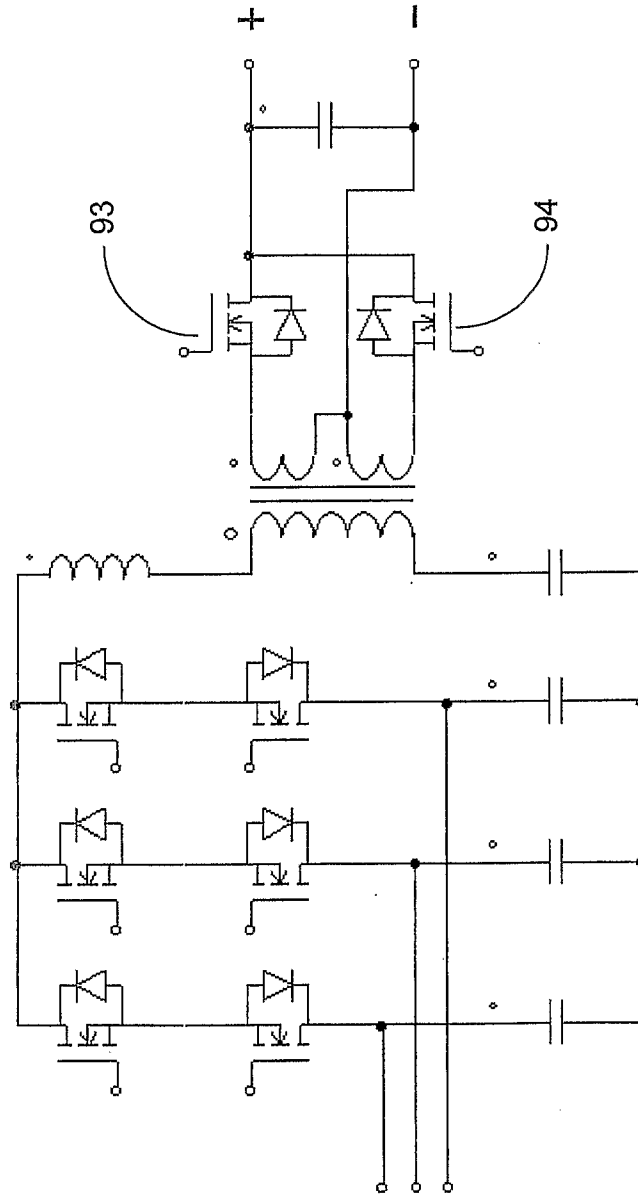

Figure 17