

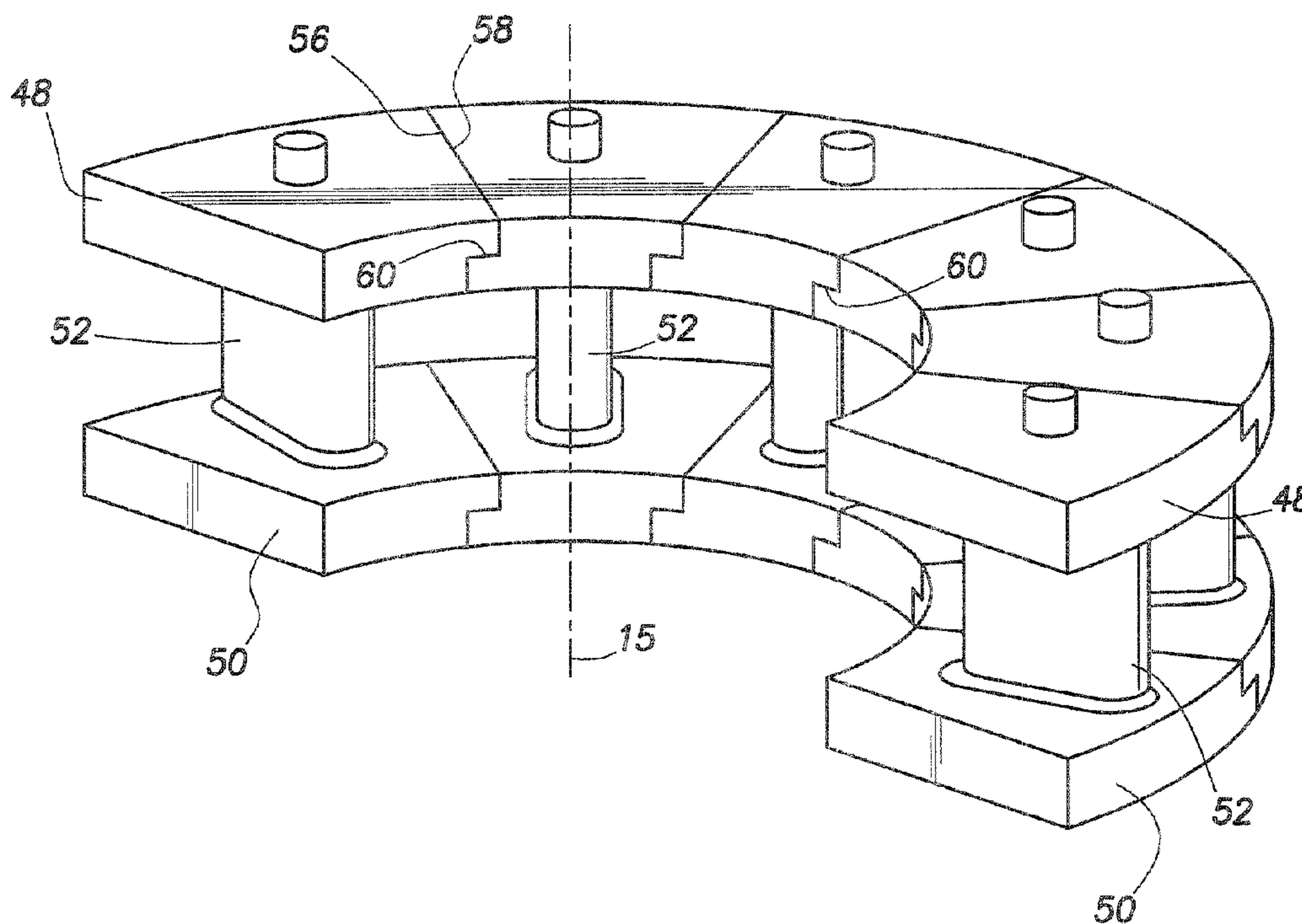

(22) Date de dépôt/Filing Date: 2004/07/02
 (41) Mise à la disp. pub./Open to Public Insp.: 2005/01/11
 (45) Date de délivrance/Issue Date: 2007/09/18
 (30) Priorités/Priorities: 2003/07/11 (US60/486,499);
 2004/01/30 (US10/769,022)

(51) Cl.Int./Int.Cl. *E21B 33/06* (2006.01),
E21B 33/12 (2006.01)
 (72) Inventeurs/Inventors:
 MELANCON, JEFFREY T., US;
 MCWHORTER, DAVID J., US
 (73) Propriétaire/Owner:
 VARCO I/P, INC., US
 (74) Agent: LEDGLEY, CYNTHIA J.

(54) Titre : BELIER A DIAMETRE DE FORAGE VARIABLE
 (54) Title: VARIABLE BORE RAM



(57) Abrégé/Abstract:

A ram type blowout preventer includes variable ram packers for sealing about tubulars of different outside diameters in the bore of the preventer housing or about a single tubular having a variable outside diameter. Each ram packer includes a body of elastomeric material formed about vertical ribs to conform to tubular having variable OD within a certain range.

ABSTRACT OF THE DISCLOSURE

A ram type blowout preventer includes variable ram packers for sealing about tubulars of different outside diameters in the bore of the preventer housing or about a single tubular having a variable outside diameter. Each
5 ram packer includes a body of elastomeric material formed about vertical ribs to conform to tubular having variable OD within a certain range.

VARIABLE BORE RAM

FIELD OF THE INVENTION

The present invention relates generally to the field of blowout preventers (BOPs), and, more particularly, to a ram packer that
5 accommodates tubulars of varying diameters or of one tubular having a varying diameter.

BACKGROUND OF THE INVENTION

Blowout preventers maintain control of downhole pressure in wells
10 during drilling, and ram-type blowout preventers are used to close and seal around a string of pipe or coiled tubing extending into the well to contain the pressure within the well. Variable bore packers have been designed for ram-type blowout preventers to close and seal around tubular members having different diameters within a limited range of sizes. Variable bore packers are
15 designed to adjust their sealing engagement to the particular size of tubular member passing through the ram-type blowout preventer. Various types of prior art variable bore packers have been utilized.

U.S. Pat. No. 4,229,012 discloses a variable bore packer for a ram-type blowout preventer in which iris inserts, operated like a camera shutter,
20 are embedded in a resilient packer. Each insert includes an upper plate, a lower plate, and a rib fixed between the upper and lower plates. Each of the plates is generally triangular in shape and designed to rotate as it moves inwardly with the resilient packer annulus so that the resilient material is supported when in sealing engagement with the exterior of a tubular member
25 extending through the BOP.

U.S. Pat. No. 5,005,802 discloses a variable bore packer having an upper and lower plate embedded in resilient packer material. A series of upper insert segments are positioned in the packer material below the upper
30 plate and are removable with the packer material as it moves forward during sealing. The insert segments move inward with the packer material in sealing

to provide an upper anti-extrusion support for the packer material upon sealing engagement around the exterior of a tubular member extending through the blowout preventer. The insert segments include an inner radius sized to match the outside diameter of the pipe against which it is to seal.

- 5 The insert segments also include a radial length which is sufficiently long to allow them to move into engagement with a pipe exterior and still provide support for the resilient packer material to avoid its extrusion.

As variable bore packers sealingly engage tubular strings of different sizes, it is important to prevent the extrusion of the resilient packer material between the variable bore packer and the tubular member. Prior art packers
10 continue to be subject to extrusion such that upon closing the variable bore packer around the tubular member, minute gaps continue to exist between the packer and tubular member. Such gaps become an increasing problem as the packer wears and is abraded by its sealing engagement with various
15 tubular members passing through the blowout preventer. At times, a "stripping" operation must be performed to strip the string through the closed rams. This stripping movement can severely wear or abrade the face of the resilient packer material.

The problem of extrusion is enhanced with increased downhole
20 pressure and/or increased temperature. As downhole pressures increase to 15,000 psi, such large downhole pressures exacerbate the problem of extrusion due to the great pressure differential across the packer. Seventy or eighty pressure cycles is a typical life span for ambient temperature packers. In high temperature packers, however, much more wear occurs in one cycle
25 than in an ambient temperature packer. Further, as temperatures increase to high temperatures in the order of 350°F, the viscosity of the resilient packer material decreases causing it to be more fluid and thereby more susceptible to extrusion through the minute gaps between the packer and tubular member.

30 The variable bore packer of U.S. Pat. No. 4,229,012 does not lend itself to high temperature applications because it does not create a tight seal around the tubular member. The iris inserts cannot conform well to the

diameter of the tubular member and leave a plurality of small gaps allowing extrusion by the less viscous packer material.

McWhorter *et al.*, in U.S. Patent No. 5,005,802, provided a packer for use with a ram-type blowout preventer having the capacity to accommodate a plurality of sizes of tubular members extending through the bore of the blowout preventer. The packer had a resilient body to fit the face recess of the ram and a central recess to receive a tubular member, an upper plate positioned in the upper portion of the resilient body, a lower plate positioned in the lower portion of the resilient body, and a plurality of metal insert segments positioned between the upper surface of the resilient body and the under surface of the upper plate and around the central recess of the resilient body.

In U.S. Patent No. 5,294,088, McWhorter *et al.* provided another variable bore packer for a ram-type blowout preventer. The packer included a body of resilient packing material with upper and lower plates embedded in the upper and lower surfaces of the body and upper and lower sets of insert segments disposed adjacent the upper and lower plates. Each of the insert segments includes a pair of insert plates forming an arcuate opening to receive an appropriate sized tubular member and dimensioned to expand and move rearwardly in the resilient packing material upon engagement with a larger diameter tubular member.

However, new tubulars in use in the field include a first section of a first diameter, a second section of a second diameter, and tapered section joining the first and second sections. The prior art packers just described are not well adapted to accommodate this new design of tubulars. Further, known packers suffer from excessive tensile stress when subjected to high pressure differentials. The present invention is directed to solving this problem in the art.

SUMMARY OF THE INVENTION

The ram of the present invention seals around downhole tubulars, such as for example drill pipe, coiled tubing, and the like, of varying outside

diameters at pressures up to 15,000 psi. The ram is provided as a part of a blowout preventer. In a manner known in the art, ram elements work in pairs driven by two opposing pistons. A sealing element comprises elastomeric material with embedded metallic inserts that prevent extrusion under
5 pressure. These sealing elements are nested within a metallic ram block. In the present invention, the sealing elements flexibly adapt to various sizes of tubulars within a given range.

A two piece support "bone" eliminates tensile stress in the bone column experienced by certain known rams. This support bone allows the column to
10 be of a reduced size which allows for more and better rubber flow. The column is used only for rigidity during the molding process and to coordinate the movements of the upper and lower pie shaped ends of the "bone". In prior art ram designs, the column must be so large that it would impede rubber flow.

15 All metallic members of the sealing element are mechanically locked to the ram while still having freedom of movement. Parts can not fall down hole even if all rubber is lost from the ram. Known rams can drop inserts downhole if the rubber is lost.

Bones are linked to slots in the upper and lower plates which, in
20 addition to preventing loss downhole, strictly regulate the direction of motion of the inserts as they flex to conform to the pipe.

The combination of bones and upper and lower plates gives the ram of the present invention minimum extrusion points between variable sizes of pipe and a flush front face packer design. Other ram designs have inserts
25 protruding beyond the frontal plane of the seal. Such designs are hard to mold in existing pipe ram front seal tooling, and suffer other problems.

30

In accordance with an aspect of the present invention, there is provided a variable bore ram packer comprising:

- a. an upper plate;
- b. a lower plate;
- c. plurality of wedge-shaped segments between the upper and lower plates, wherein each of the plurality of wedge-shaped segments comprises:
 - i. a top pie-shaped section;
 - ii. a bottom pie-shaped section having a non-circular rib-receiving recess therein; and
 - iii. a rib between the top and bottom pie-shaped sections, the rib defining a non-circular cross section of a size and shape to slidingly engage the recess in the bottom pie-shaped section; and
- d. an elastomeric material between the wedge-shaped segments.

In one embodiment of the present invention, each of the plurality of wedge-shaped segments comprises:

- a. a top, pie-shaped section;
- b. a bottom, pie-shaped section; and
- c. a rib between the top and bottom pie-shaped sections.

In another embodiment, the elastomeric material fills in between the top and bottom pie-shaped sections and around the rib.

In another embodiment, the top section of the packer includes a straight edge with a step therealong, adapted to mate with a complementary step along a straight edge of an adjacent top section.

In another embodiment, the bottom section of the packer includes a straight edge with a step therealong, adapted to mate with a similar step along a straight edge of an adjacent bottom section.

In another embodiment, the top section of the packer defines an undersurface and further comprising a groove in the undersurface to receive the rib.

In another embodiment, each of the plurality of wedge-shaped segments further comprises:

- d. an upper pin extending from the top section;
- e. a bottom pin extending from the bottom section;
- f. a recess in the upper plate to receive the upper pin; and
- g. a recess in the lower plate to receive the bottom pin.

These and other features and advantages of this invention will be readily apparent to those skilled in the art.

BRIEF DESCRIPTION OF THE DRAWINGS

So that the manner in which the above recited features, advantages and objects of the present invention are attained and can be understood in detail, more particular description of the invention, briefly summarized above, may be had by reference to embodiments thereof which are illustrated in the
5 appended drawings.

Figure 1 is a side view, partially in section, of a ram-type blowout preventer in which the packer of the present invention is installed.

Figure 2 is a perspective view of a ram of this invention.

10 Figure 3 is a perspective view of metal support elements for the elastomeric sealing components of the invention.

Figure 4 is a perspective view of one of either an upper or a lower plate.

15 Figure 5 is a perspective view of a ram showing the placement of the packer.

Figures 6A through 6D depict various views of one metal support segment.

DETAILED DESCRIPTION OF A PREFERRED EMBODIMENT

20 Referring initially to Figure 1, there is shown a ram-type blowout preventer **10** which includes a housing or body **12** having a central vertical bore **14** therethrough with aligned opposed ram guideways **16** extending radially outward through body **12** from opposite sides of bore **14**. The bore **14** defines a central axis **15**. The blowout preventer **10** is similar to the blowout
25 preventer illustrated in U. S. Pat. No. 5,005,802, incorporated herein by reference. Each guideway **16** has a generally round, oval, or rectangular cross-section and includes a ram **18** reciprocally disposed therein. Each ram **18** is connected to an actuation means **20**, such as a piston **22**, by an actuator connecting rod **24** for moving rams **18** axially within their respective

guideways **16** to open or close bore **14**. While only one guideway **16** and ram **18** are shown, it is understood that there are two opposed guideways **16** and a ram **18** in each guideway **16**.

Each ram **18** includes a front face slot **26**, only partially shown, for
 5 receiving a suitable packer therein with means coacting with the packer for
 securing it within slot **26**. Packers normally are made of a resilient material
 and function to engage and seal against the exterior of a tubular member (not
 shown) which extends through central bore **14** and against which the ram
 packers are to close. Ram top seal **28** extends across the top of each ram **18**
 10 in groove **30** to provide a seal between ram **18** and the interior of guideway
16. Top ram seal **28** coacts with the packer to retain well pressure below
 rams **18** when rams **18** are in the closed position.

The ram shown in Figure 1 has proved to be effective for the purposes
 for which it was designed, but suffers the drawbacks previously mentioned.
 15 The present invention comprises a ram that seals around tubular of a varying
 outside diameter and seals at high pressure, and is shown in detail in Figure
 2. A ram element **40** includes an upper plate **42**, a lower plate **44**, and a
 plurality of wedge-shaped sealing elements **46** between the upper and lower
 plates. Each of the wedge-shaped sealing elements includes an upper plate
 20 **48**, a lower plate **50**, and a vertical rib **52** between the upper and lower plates.

The upper plate **42** defines an arcuate surface **54** of a first diameter
 and the upper plate **48** and the lower plate **50** of the wedge-shaped elements
46 also define an arcuate surface having a second diameter smaller than the
 first diameter of the arcuate surface **54**.

Figure 3 shows more details of the wedge-shaped sealing elements
 25 including the upper plate **48**, the lower plate **50**, and the vertical rib **52**
 between the upper and lower plates. A plurality of the sealing elements is
 nested together to form an entire sealing device, and the entire sealing device
 is oriented about the axis **15** (see Figure 1). Each of the pie-shaped sections
 30 of the upper plate **48** has a straight side **56** and a straight side **58**, fitting
 together with a step **60** therebetween. This step **60** permits the sides of the
 pie-shaped sections to slide relative to one another, supporting each other

vertically without creating an axial tensile stress between elements. Note also that the ribs 52 are merely supported between the plates and are not fixed thereto as shown below in Figures 6A and 6B, thereby eliminating the tensile stress common in the art.

5 Each upper plate 48 includes an upwardly extending pin 49 therefrom. A similar pin extends below the lower plate 50. The pins coact with grooves in the upper and lower plates 42 and 44 as shown below.

 Figure 4 shows the upper plate 42 (or a lower plate 44, since they are constructed in a similar manner). The plate 42 includes openings 66 to
10 receiving vertical support members that extend between the plate 42 and the plate 44. The plate 42 also includes a plurality of grooves or recesses 68, each of which is configured and adapted to receive a pin 49. Note that each pin slides within its recess radially inwardly, thereby applying an inward sealing pressure against a tubular within the BOP. The grooves or recesses
15 68 further provide the feature of capturing a respective vertical pin 49, and thus the sealing element, so that in the event that the polymeric material of the ram breaks up or is expended, the sealing element is retained by the upper and lower plates 42 and 44 and does not fall down hole.

 Figure 5 shows the ram element 40 operatively mounted in a ram 18 as
20 previously described in respect of Figure 1. Figures 6A through 6D show various views of the wedge-shaped element comprised of pie-shaped sections 46 and 48 with a rib 52 therebetween.

 The principles, preferred embodiment, and mode of operation of the present invention have been described in the foregoing specification. This
25 invention is not to be construed as limited to the particular forms disclosed, since these are regarded as illustrative rather than restrictive. Moreover, variations and changes may be made by those skilled in the art without departing from the spirit of the invention.

WHAT IS CLAIMED IS:

1. **A variable bore ram packer comprising:**
 - a. **an upper plate;**
 - b. **a lower plate;**
 - c. **plurality of wedge-shaped segments between the upper and lower plates, wherein each of the plurality of wedge-shaped segments comprises:**
 - i. **a top pie-shaped section;**
 - ii. **a bottom pie-shaped section having a non-circular rib-receiving recess therein; and**
 - iii. **a rib between the top and bottom pie-shaped sections, the rib defining a non-circular cross section of a size and shape to slidingly engage the recess in the bottom pie-shaped section; and**
 - d. **an elastomeric material between the wedge-shaped segments.**

2. **The packer of claim 1, wherein each of the plurality of wedge-shaped segments comprises:**
 - a. **a top, pie-shaped section;**
 - b. **a bottom, pie-shaped section; and**
 - c. **a rib between the top and bottom pie-shaped sections.**

3. **The packer of claim 2, wherein the elastomeric material fills in between the top and bottom pie-shaped sections and around the rib.**

4. **The packer of claim 2, wherein the top section includes a straight edge with a step therealong, adapted to mate with a complementary step along a straight edge of an adjacent top section.**

5. **The packer of claim 2, wherein the bottom section includes a straight edge with a step therealong, adapted to mate with a similar step along a straight edge of an adjacent bottom section.**

6. The packer of claim 2, wherein the top section defines an undersurface and further comprising a groove in the undersurface to receive the rib.

7. The packer of claim 2, further comprising:
 - a. an upper pin extending from the top section;
 - b. a bottom pin extending from the bottom section;
 - c. a recess in the upper plate to receive the upper pin; and
 - d. a recess in the lower plate to receive the bottom pin.

+

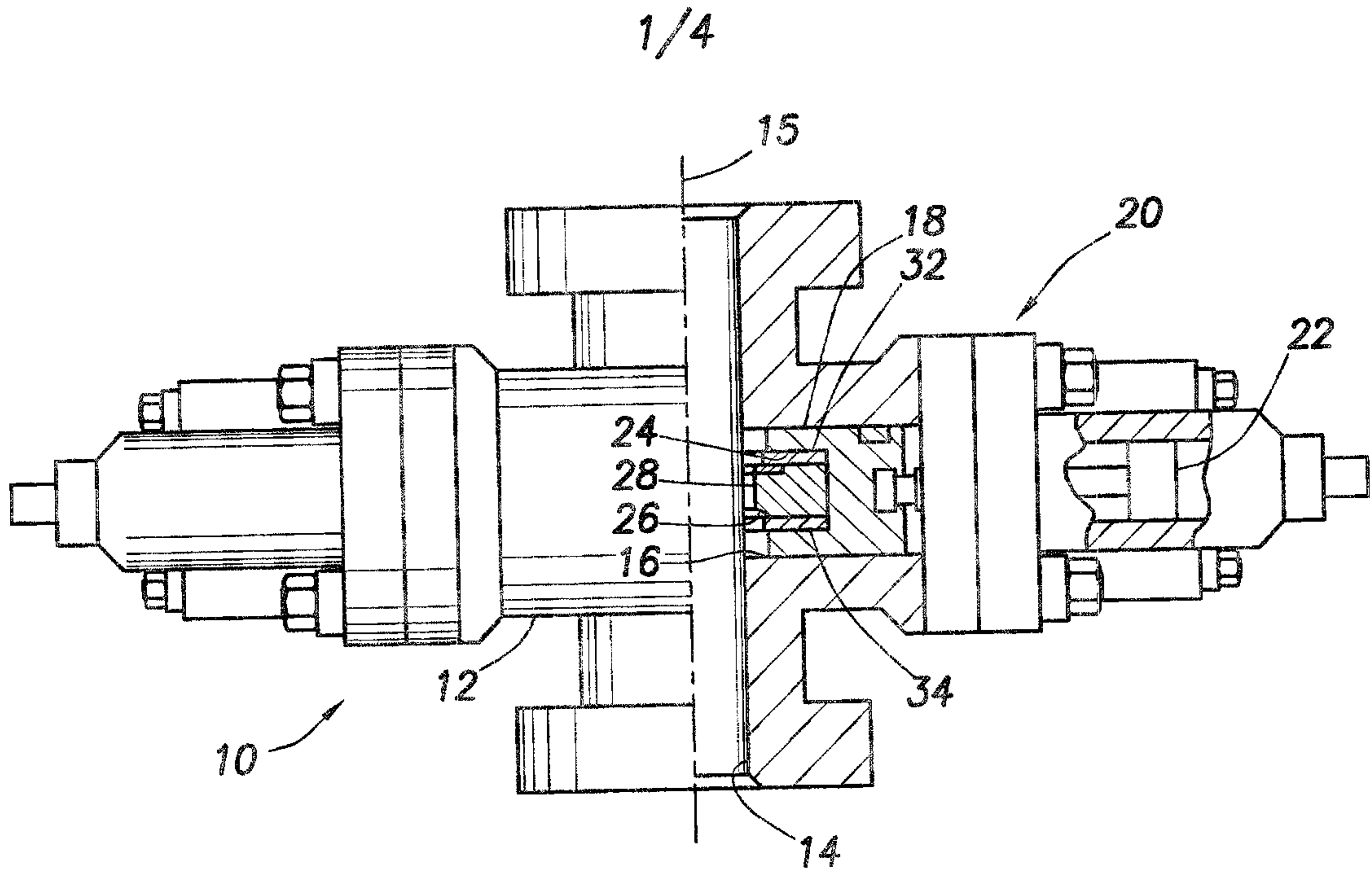

FIG. 1
(PRIOR ART)

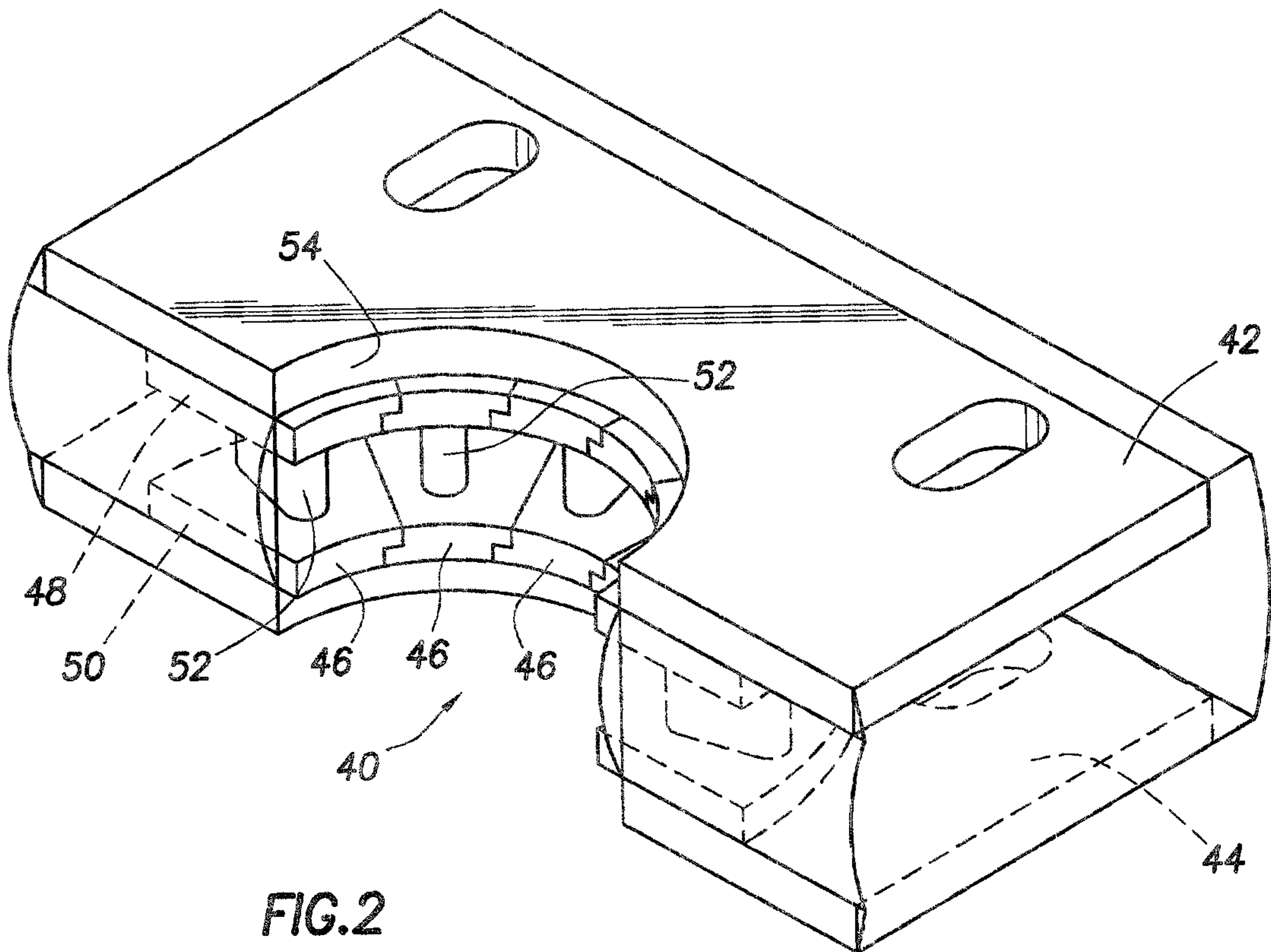

FIG. 2

+

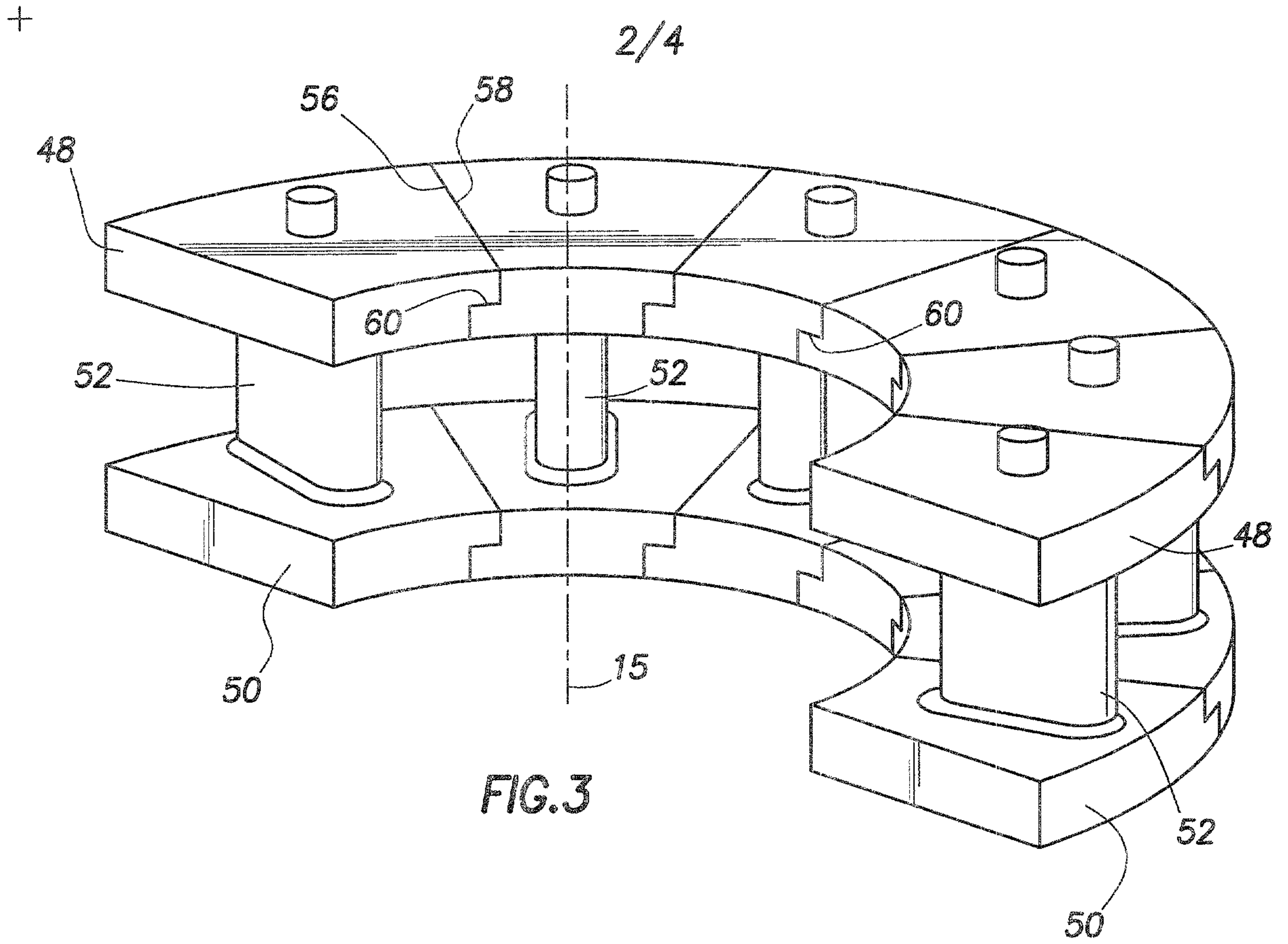

FIG. 3

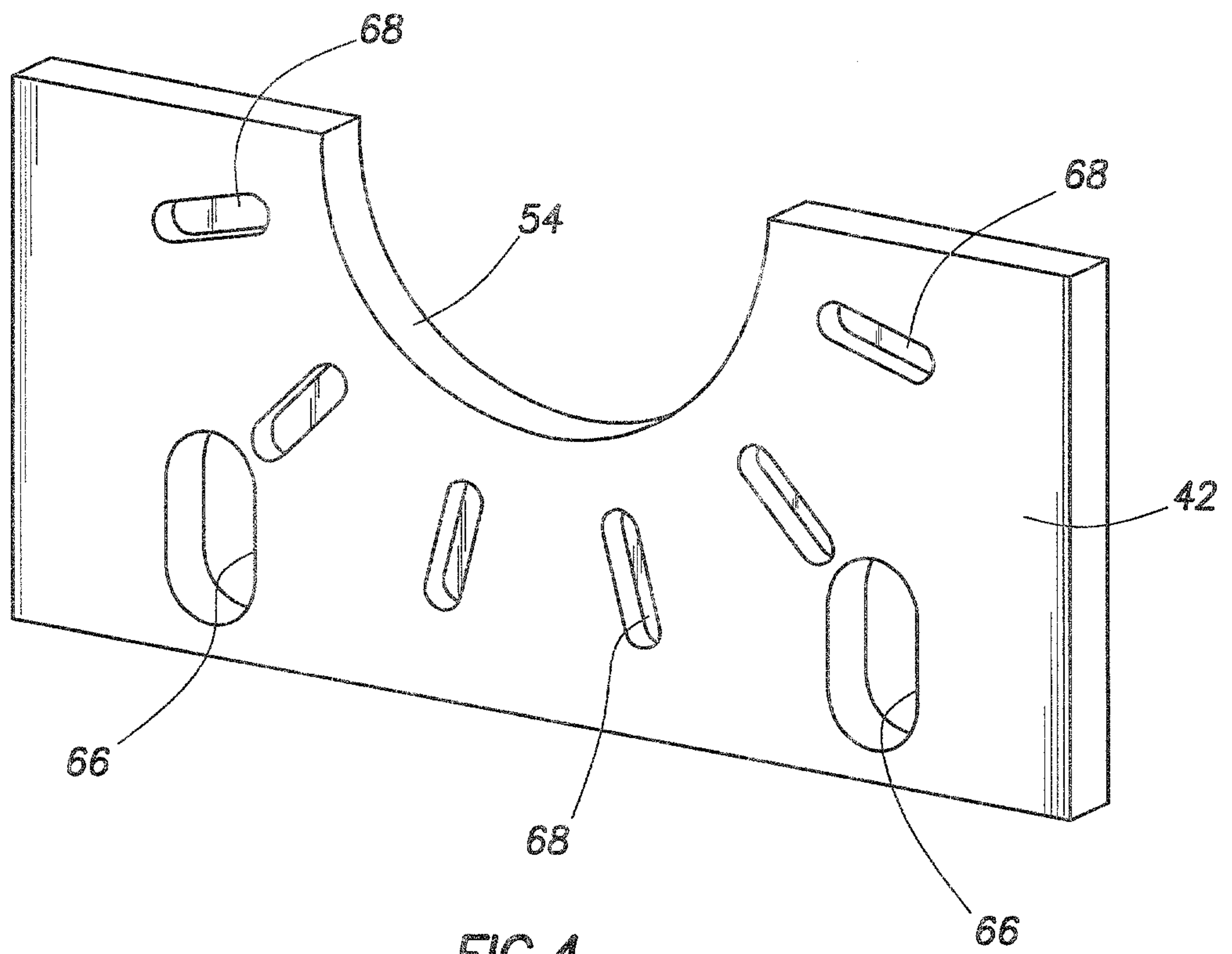

FIG. 4

+

3/4

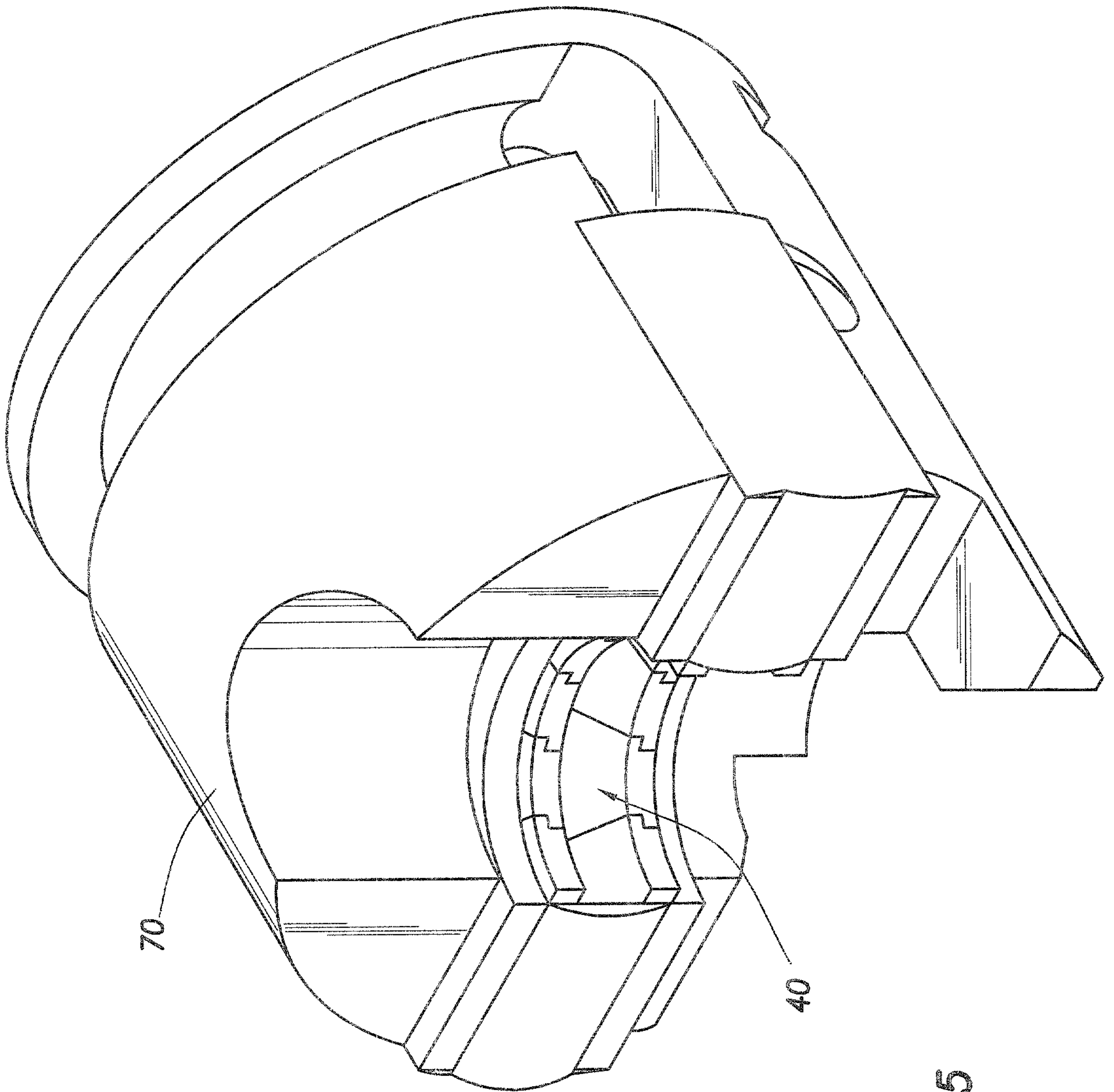
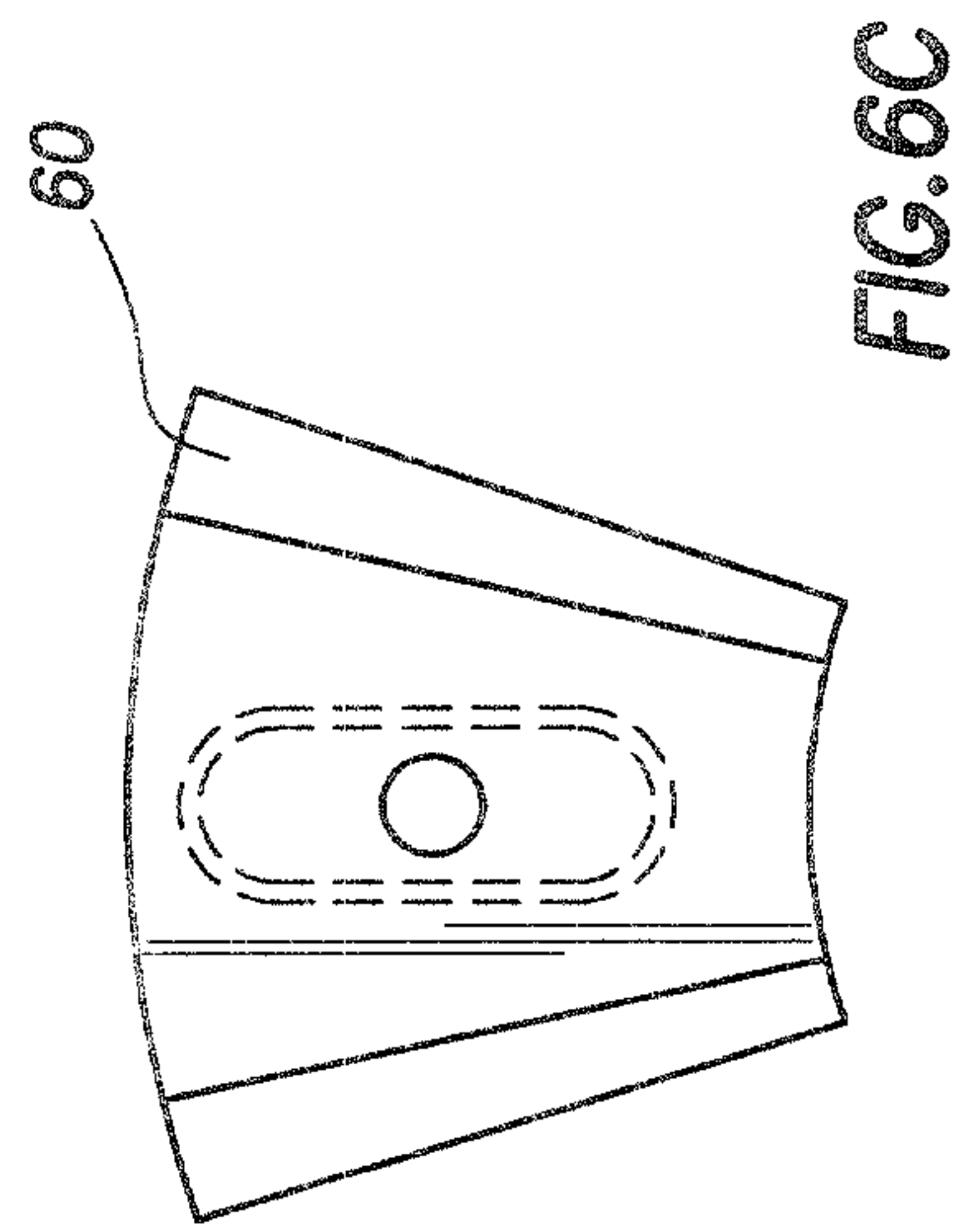
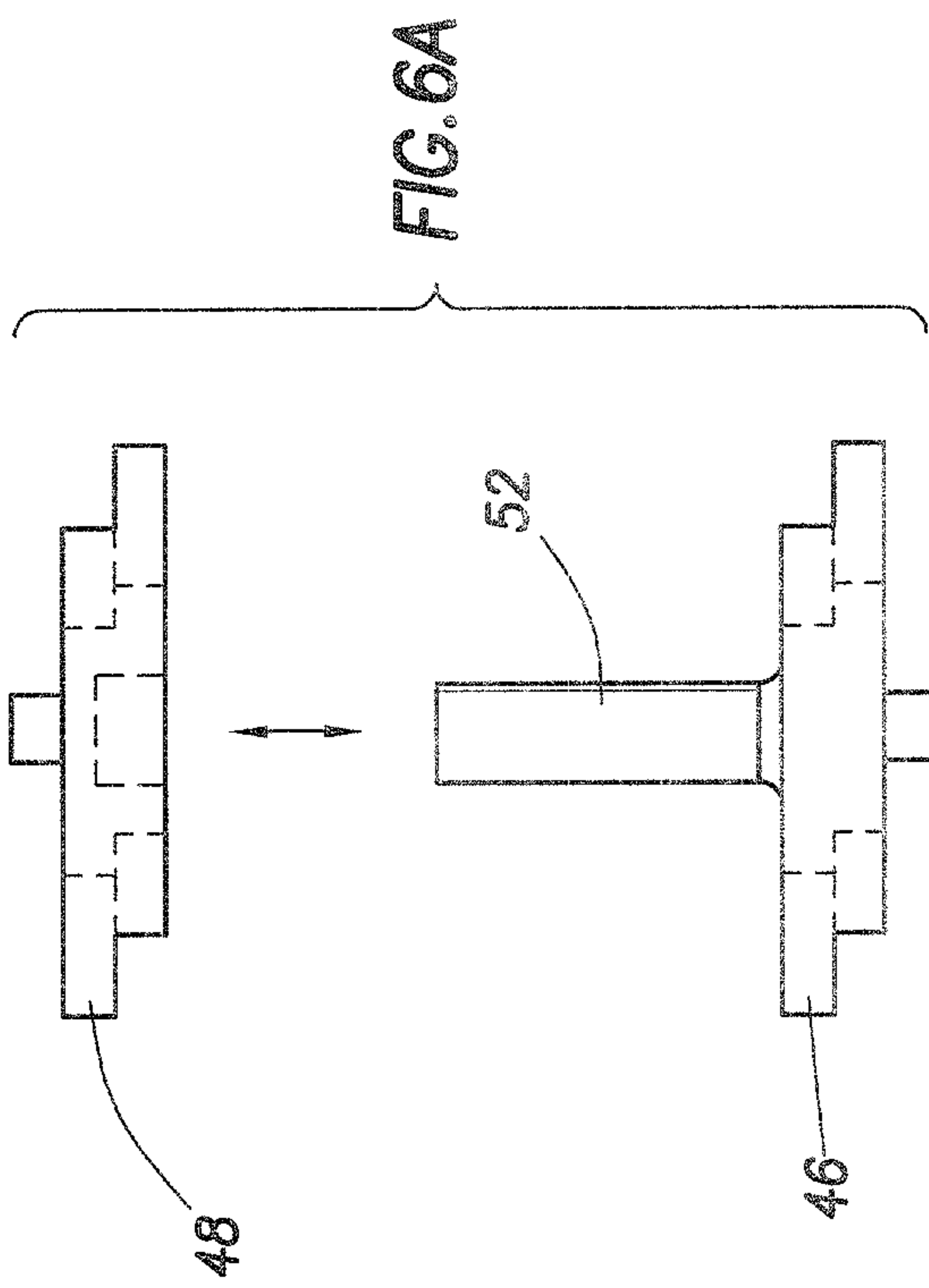
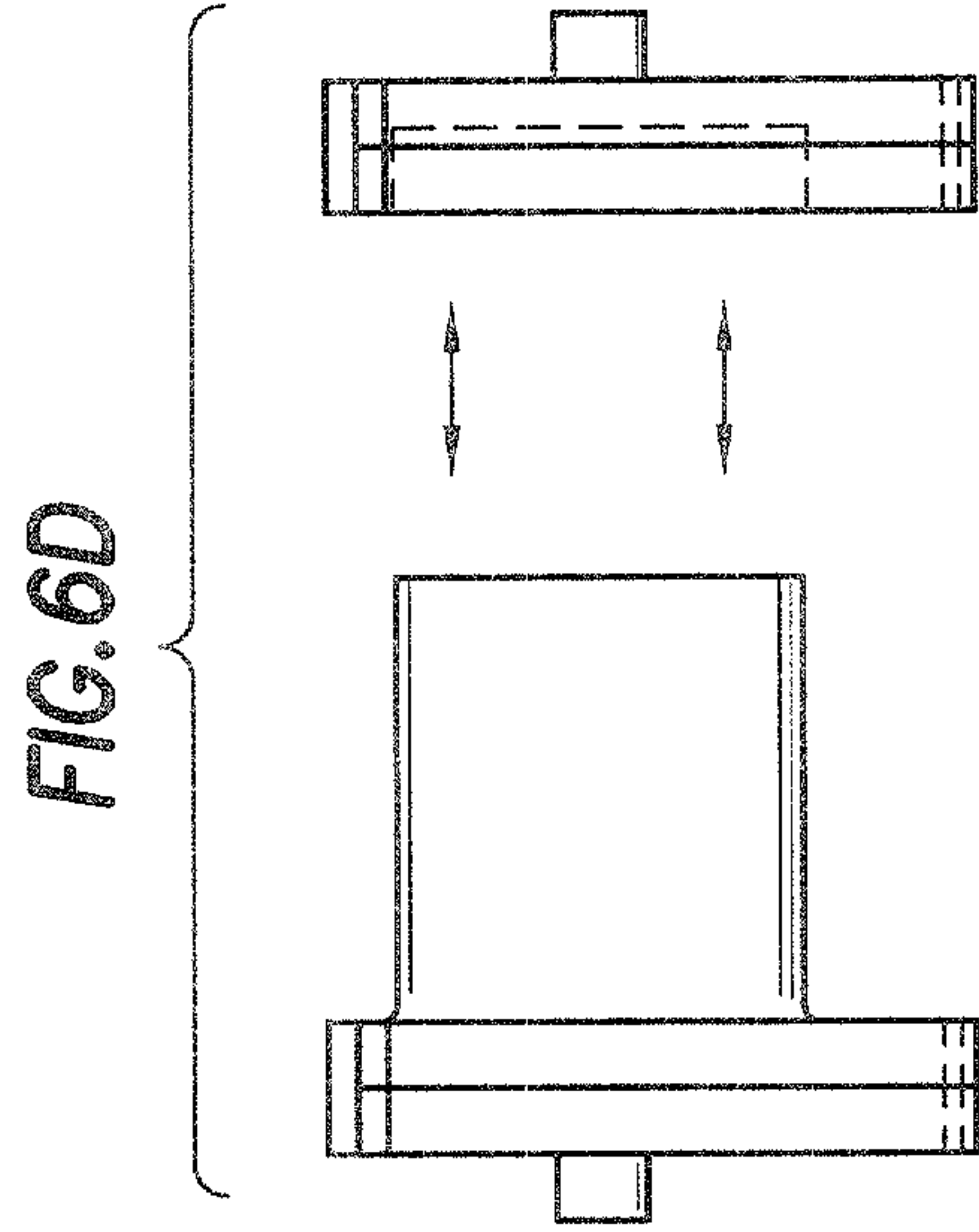
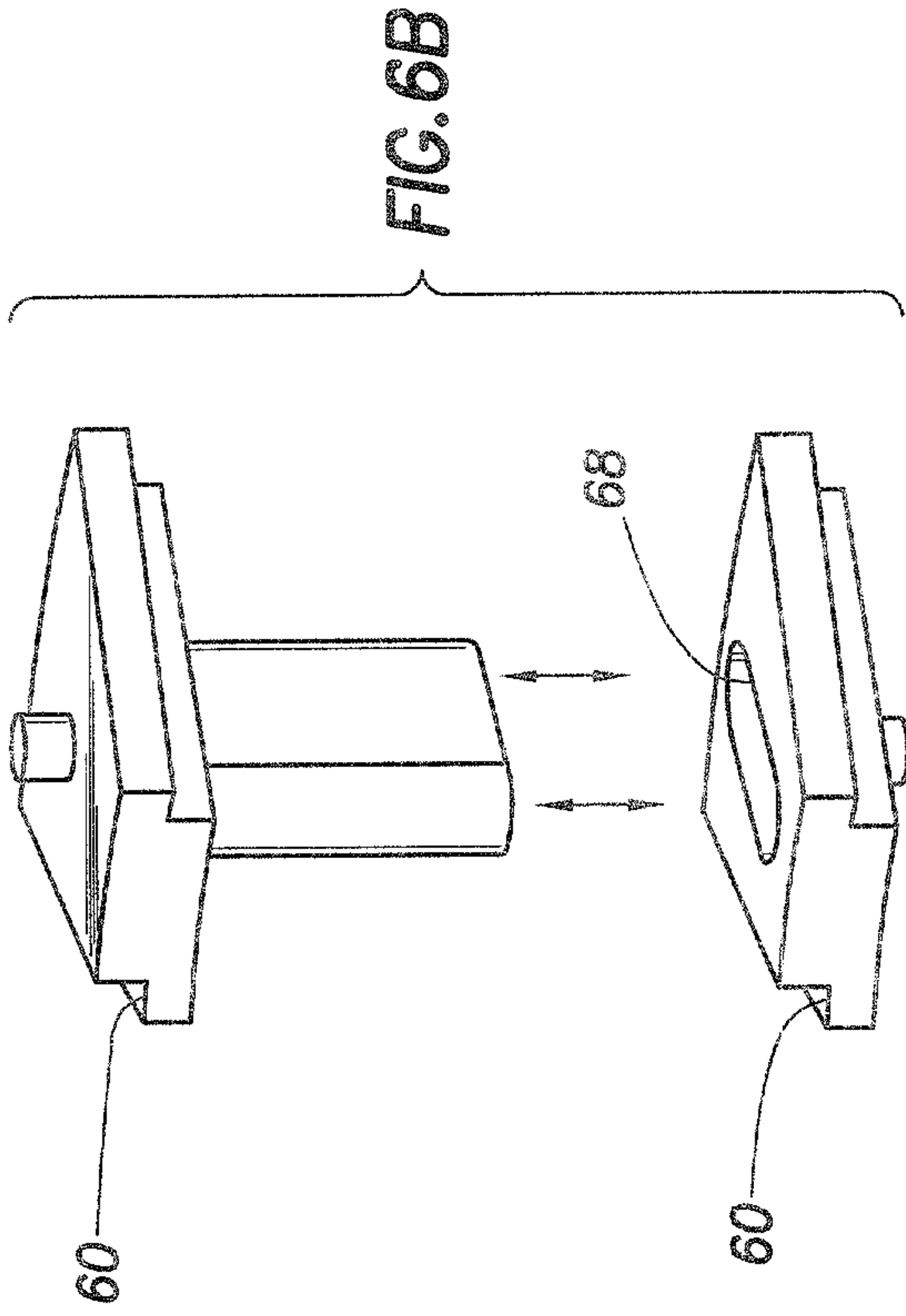

FIG. 5

+

+



+

