

Z. D. WATERS.  
Horse-Power.

No. 164,352.

Patented June 8, 1875.

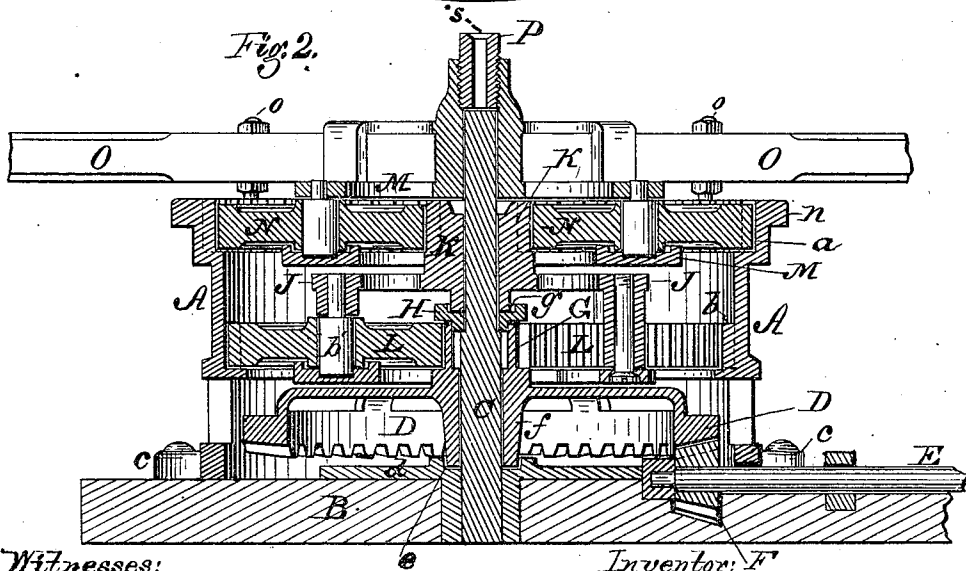
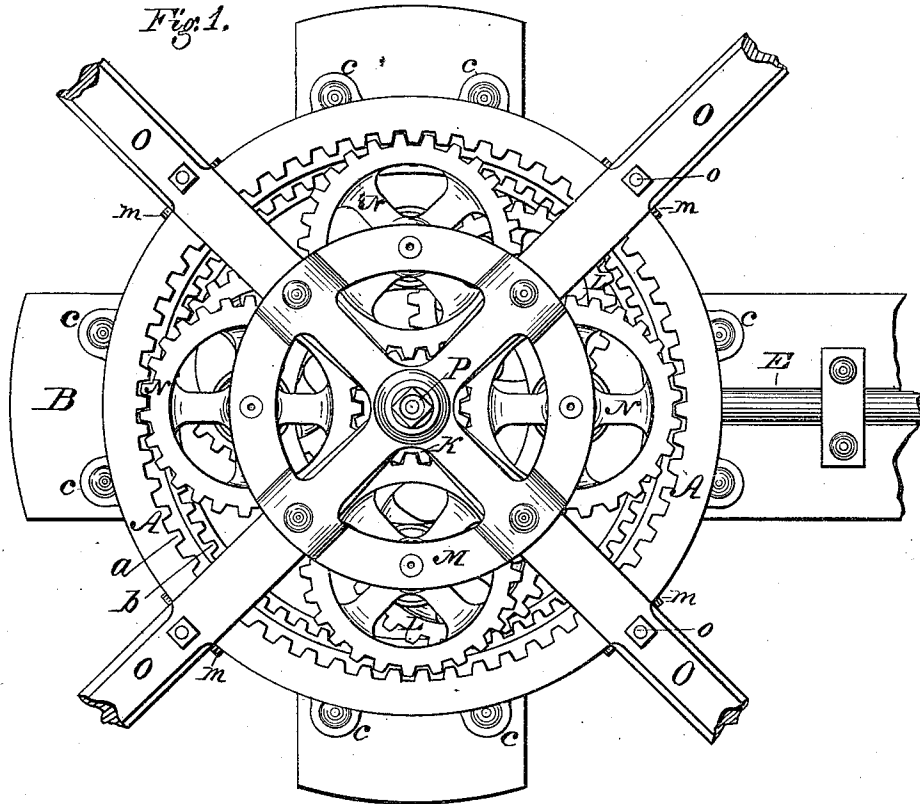

Witnesses:  
 Will H. Dodge  
 or  
 James Twitchell

Inventor: F  
 Z. D. Waters  
 by Dodge & Co.  
 Attys.

Z. D. WATERS.  
Horse-Power.

No. 164,352.

Patented June 8, 1875.

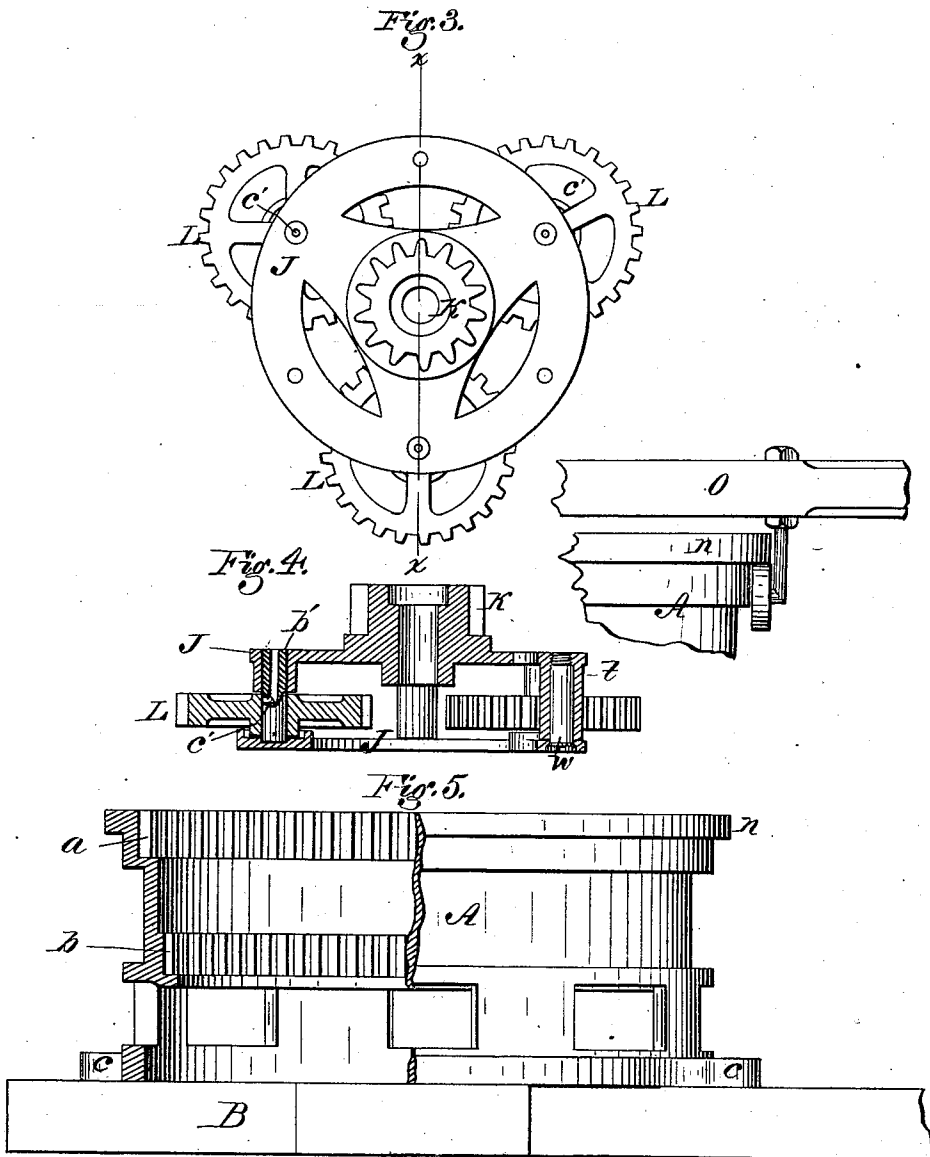

Witnesses:  
Will H. Dodge.  
Dennis Twitchell.

Inventor:  
Z. D. Waters.  
By Dodge & Son  
Attys.

# UNITED STATES PATENT OFFICE.

ZACHARIAH D. WATERS, OF BROOKVILLE, MARYLAND.

## IMPROVEMENT IN HORSE-POWERS.

Specification forming part of Letters Patent No. **164,352**, dated June 8, 1875; appl. cation filed May 22, 1875.

*To all whom it may concern:*

Be it known that I, ZACHARIAH D. WATERS, of Brookville, in the county of Montgomery and State of Maryland, have invented certain Improvements in Horse-Powers, of which the following is a specification:

My invention consists in the combination of a cylindrical body or shell, provided with two internal rows of cog-teeth, and a peculiar combination of wheels and pinions revolving therein around and about a central shaft; in a peculiar arrangement of the parts mounted on the central shaft to admit of their being readily lubricated; in a peculiar construction of the internal rotary gear-frames; in providing the sweeps or draft-bars with rollers, engaging under a flange on the body; and in other details, as hereinafter described.

Figure 1 represents a top-plan view of my improved power; Fig. 2, a vertical central section of the same; Fig. 3, a top-plan view of the lower rotary gear-frame, Fig. 4 a central vertical section of the same; Fig. 5, an elevation of the body or case, with one side in section; Fig. 6, a view showing the arrangement of the rollers attached to the sweeps or draft-bars.

In constructing my machine, I first provide a hollow cylindrical body or shell, A, having around its inner face two rows or lines of cog-teeth, *a* and *b*, one at the top, and the other near the bottom, and having on its exterior, at its bottom, lugs *c* to receive bolts, by which it is secured rigidly to a frame or base, B, as shown in Fig. 2. In the center of the body A, upon the base B, I mount a rigid vertical shaft, C, having its lower end secured in a metal plate, *d*, which is provided around the pivot with a groove or depression, *e*, to receive and retain oil, as shown in Fig. 2. On the lower end of the vertical shaft C I mount a large bevel-gear wheel, D, having on its under side a central supporting-hub, *f*, which is seated in the oil cup or recess *e*, as shown in Fig. 2. On the base B I mount a horizontal shaft, E, provided on one end with a bevel-pinion, F, which gears into the large wheel D, as shown in Fig. 2, this shaft being the means through which motion is transmitted to the

machine or apparatus to be driven by the power. Upon the center of the wheel D I form a pinion, G, as shown in Fig. 2, the center of this pinion, and, if desired, the upper part of the wheel, being cored out, so that it does not bear upon the shaft. On the center shaft, above the pinion G, I mount a plate or washer, H, provided with a neck or hub, which fits down into the pinion, as shown, for the purpose of guiding and steadying the same on the shaft.

By coring out the pinion, or the pinion and wheel, I reduce the bearing-surface on the central shaft, and lessen the friction, while at the same time, by giving the bearing at the upper and lower ends, a considerable distance apart, I give the wheel and pinion ample support, and prevent them from becoming untrue.

The plate or washer is supported, as shown, on a shoulder on the central shaft, in order to prevent it from bearing upon the pinion G, and it is provided in its upper face with an annular recess or depression, *g*, to form an oil-cup, as shown in Figs. 2 and 5.

On the central shaft, resting upon the plate or washer H, I mount a circular rotating frame, J, provided on its top with a central pinion, K, and carrying three pinions, L, each of which latter gears into the pinion G, and into the lower circle of teeth *b* in the case or body A, as shown in Fig. 2. The frame J is composed of two plates, connected by bolts and by vertical pintles or journals, on which the pinions revolve, as hereinafter more fully explained, and is provided with a hub or boss, which fits down into the recess or oil-cup in the plate H, as shown in Fig. 2. Above the frame J, on the central shaft, I mount a second rotating frame, M, carrying four pinions, N, each of which gears into the pinion K, and into the upper circle of teeth *a* in the body A, as shown in Figs. 1 and 2. The frame M is provided with sockets to receive the sweeps or draft-bars O, each of which is provided with a roller, *m*, bearing under a flange, *n*, formed around the upper edge of the body A, as shown in Fig. 2. Each roller is mounted on the lower end of a vertical threaded rod, *o*, which is

passed through the sweep, and provided with nuts above and below the same, as shown, to permit a vertical adjustment of the roller, as may be required. The frame M is, it will be seen, supported on the upper end of the central shaft, so that it has a very small bearing, and runs very easily. In order to permit compensation for the wear on the end of the shaft and in the seat, the frame M is provided with a central vertical screw, P, to rest upon the end of the shaft and receive the wear, so that by setting the screw downward the frame may be raised, as required.

Through the center of the screw I make a hole, s, through which to introduce oil; but it is obvious that in case of the screw being omitted the oil-hole may be made in the frame. Each of the gear-frames J and M consists of two parts, between which the wheels are secured. The frame J is clearly shown in Figs. 3 and 4, the upper part or plate being provided with hollow lugs t, through which bolts w are passed to hold the lower plate or ring a' in place. The lugs serve to hold the two parts at the proper distance apart, and to support and hold the bolts in such manner that the plates cannot change their relative positions, thus retaining the pivots or journals of the wheels in a true vertical position, and preventing the parts from binding. The journals or pivots b' are supported by means of the two plates or parts at both ends. They may be inserted after the plates are cast, or they may be placed in the mold and cast fast in one of the plates, as preferred. Each journal is provided with an oil-hole, e', entering at the center, and extending out through one side, as shown.

Each pinion is provided on its under side with a central hub or boss, e', fitting down into a recess or oil-cup made in the bottom plate of the frame, as shown in Figs. 2 and 4, so that the oil accumulating and being retained therein will find its way up around the journal and keep the same thoroughly lubricated.

So far as the construction and arrangement of the journals of the upper frame M is concerned, it is the same as the lower one, the only difference being that the upper frame is made with sockets to receive the inner ends of the radial arms or sweeps.

When the machine is in operation the sweeps revolve the upper frame M upon the shaft C, and cause the pinions N to travel around over the circle of fixed teeth a, which rotate the said pinions N, and cause them in turn to rotate the pinion K and its frame J, which latter causes the pinions L to travel around over the circle of fixed teeth b, which teeth rotate the pinions L, and cause them to rotate the pinion G and its wheel D, from which latter motion is communicated to the pinion F, and thence to the shaft E.

By combining the stationary body, having its two lines of teeth, with the internal gear-

ing in the manner shown, the speed is multiplied greatly, while at the same time the machine is rendered compact, durable, and cheap.

As the gearing is all inclosed within and protected by the body, the machine is handled readily, and danger of breakage in transportation avoided.

The manner in which the gearing is inclosed also prevents any danger of obstructions falling therein, and of the gearing catching the clothing of the attendant and drawing them into the machine.

By arranging the gearing on the central shaft and making the provisions shown for the introduction and retention of the oil, the wearing surfaces are kept thoroughly lubricated, and the necessity of frequent attention avoided.

The oil introduced at the top first flows down over the bearings of the top frame, and then down into the bearing of the lower frame, and finally down into the bearing of the bottom wheel, the introduction of oil at one point thus serving to lubricate the various parts revolving on the central shaft.

The oil cups or recesses at the lower side of the pinions, retaining a quantity of oil, enable the machine to run for a long time without attention.

The washer applied to the shouldered central shaft receives the entire weight of the lower frame and its pinions, and thus prevents the parts from binding, and reduces the friction to the least possible amount.

The employment of the adjustable bearing for the top frame permits a ready compensation for wear, and enables the operator to keep the parts in such position as to work easily and smoothly.

The employment of the rolls on the arms to engage under the flange on the body causes the parts to run smoothly, prevents the arms from vibrating, and renders the action of the machine better in other respects.

Having thus described my invention, what I claim is—

1. In combination with the stationary body or shell A, having the two rows of teeth a and b, the central shaft C, the frame M, provided with the pinions N, the frame J, provided with the central pinion K and planetary pinions L, the pinion G, and wheel D, constructed and operating substantially as shown and described.

2. In a horse-power, the combination of an outside circular body or shell, provided with two internal rows of teeth, with two series of planet-wheels and central pinions, substantially as shown and described.

3. In combination with the shouldered central shaft C, having the wheel and pinion D G mounted thereon, the recessed plate H, supported on the shoulder of the shaft, and the gear-frame J, provided with the central hub-bearing in the plate, as shown.

4. In a horse-power, a rotary pinion-carrying frame, consisting of an upper plate and a lower plate, one of said plates being provided with lugs *t*, and the two plates being united by bolts *w*, as shown.

5. In combination with the pinions, having central hubs on their under sides, the frames provided with oil cups or recesses to receive said hubs, as shown and described.

6. In a horse-power, the combination of a vertical central shaft, having two or more pinions or pinion-frames mounted thereon, a foot-plate, *d*, provided with a recess or oil-cup, *e*, and a wheel or pinion supported by a hub, *f*, bearing in said recess, substantially as shown, so that the oil descending on the shaft

is finally caught at its foot and applied to the bottom pinion.

7. The gear-carrying frame M, supported by the central screw P, bearing upon the upper end of the shaft C, as shown.

8. In combination with the body A, provided with a flange, *n*, the gear-frame M, provided with the sweeps or draft-bars O, having the rollers *m* attached thereto, and arranged to bear under the flange, as shown.

ZACHARIAH D. WATERS.

Witnesses:

P. T. DODGE,  
W. C. DODGE.