

(19) World Intellectual Property Organization
International Bureau



(43) International Publication Date
17 July 2008 (17.07.2008)

PCT

(10) International Publication Number
WO 2008/085098 A1

(51) International Patent Classification:
F02M 59/08 (2006.01) F02M 63/02 (2006.01)

FLINK, Tomas [SE/SE]; Vänhemsvägen 32, S-141 30 Huddinge (SE).

(21) International Application Number:
PCT/SE2007/050992

(74) Agent: WALDEBÄCK, Hans; Scania CV AB (publ), UTY, Patents, S-151 87 Södertälje (SE).

(22) International Filing Date:
13 December 2007 (13.12.2007)

(81) Designated States (unless otherwise indicated, for every kind of national protection available): AE, AG, AL, AM, AT, AU, AZ, BA, BB, BG, BH, BR, BW, BY, BZ, CA, CH, CN, CO, CR, CU, CZ, DE, DK, DM, DO, DZ, EC, EE, EG, ES, FI, GB, GD, GE, GH, GM, GT, HN, HR, HU, ID, IL, IN, IS, JP, KE, KG, KM, KN, KP, KR, KZ, LA, LC, LK, LR, LS, LT, LU, LY, MA, MD, ME, MG, MK, MN, MW, MX, MY, MZ, NA, NG, NI, NO, NZ, OM, PG, PH, PL, PT, RO, RS, RU, SC, SD, SE, SG, SK, SL, SM, SV, SY, TJ, TM, TN, TR, TT, TZ, UA, UG, US, UZ, VC, VN, ZA, ZM, ZW.

(25) Filing Language: English

(26) Publication Language: English

(30) Priority Data:
0700023-5 8 January 2007 (08.01.2007) SE

(71) Applicant (for all designated States except US): SCANIA CV AB (PUBL) [SE/SE]; S-151 87 Södertälje (SE).

(72) Inventors; and

(75) Inventors/Applicants (for US only): KYLSTRÖM, Kim [SE/SE]; Vrånvägen 17 A, S-146 50 Tullinge (SE).

(84) Designated States (unless otherwise indicated, for every kind of regional protection available): ARIPO (BW, GH, GM, KE, LS, MW, MZ, NA, SD, SL, SZ, TZ, UG, ZM, ZW), Eurasian (AM, AZ, BY, KG, KZ, MD, RU, TJ, TM),

[Continued on next page]

(54) Title: FUEL PUMP AND A METHOD FOR CONTROLLING A FUEL PUMP

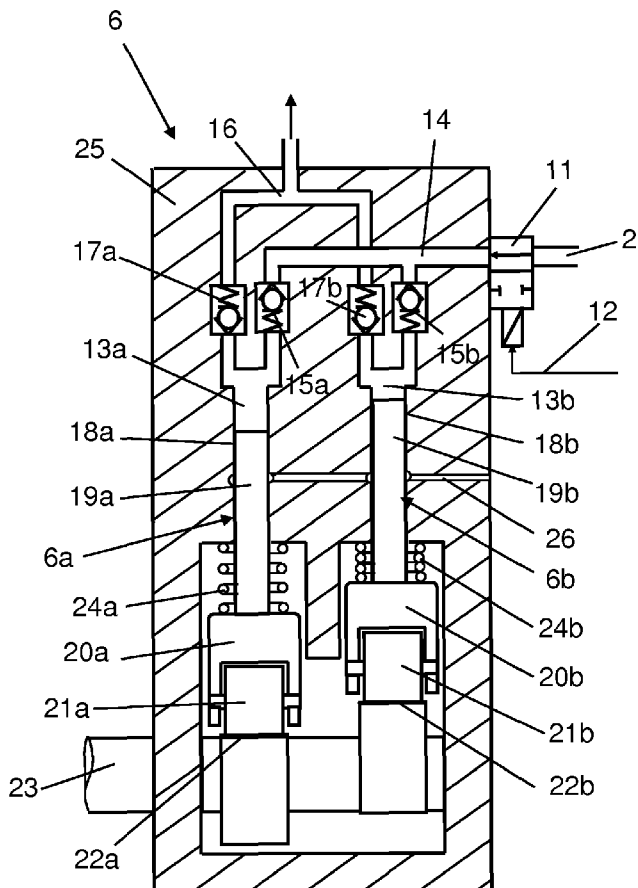

(57) Abstract: The invention relates to a fuel pump and a method for controlling a fuel pump (6). The fuel pump (6) comprises at least two pump means (6a, b) run at a mutual phase displacement such that they are able to receive fuel during different periods of time. A control unit (10) is adapted to causing a valve (11) which is only settable in an open position and a closed position to lead a desired amount of fuel to the respective pump means (6a, b). The control unit (10) is adapted accordingly to placing the valve (11) in the open position for a variable portion of said periods so that an individually controlled amount of fuel is led to the respective pump means (6a, b) during said periods. Maintenance of good efficiency of the fuel pump and low noise emissions is thus made possible in operating situations where the fuel pump delivers a reduced amount of fuel.

WO 2008/085098 A1



European (AT, BE, BG, CH, CY, CZ, DE, DK, EE, ES, FI, FR, GB, GR, HU, IE, IS, IT, LT, LU, LV, MC, MT, NL, PL, PT, RO, SE, SI, SK, TR), OAPI (BF, BJ, CF, CG, CI, CM, GA, GN, GQ, GW, ML, MR, NE, SN, TD, TG).

Published:
— *with international search report*

Fuel pump and a method for controlling a fuel pump

BACKGROUND TO THE INVENTION, AND STATE OF THE ART

- 5 The present invention relates to a fuel pump and a method for controlling a fuel pump according to the preambles of claims 1 and 11.

One way of reducing discharges of emissions from diesel engines is to inject the fuel at a very high pressure. A so-called “common rail” system is commonly used for
10 effecting injection at a high pressure in the combustion spaces of a diesel engine. A common rail system comprises a high-pressure pump which pumps fuel at a high pressure to an accumulator tank (“common rail”). The fuel in the accumulator tank is intended to be distributed to all the cylinders of the combustion engine. Fuel from the accumulator tank is injected into the combustion spaces of the respective cylinders by
15 electronically controlled injection means.

Conventional high-pressure pumps which deliver fuel to an accumulator tank usually comprise at least two pump means. The pump means work alternately so that when one pump means pressurises fuel, fuel is fed into the second pump means. The high-
20 pressure pump can thus deliver a substantially continuous fuel flow at a high pressure to an accumulator tank. The fuel flow to the respective pump means is controlled by a regulating valve which has a variable constriction. Depending on the load on the combustion engine, the constriction of the regulating valve is varied so that the high-pressure pump delivers a desired amount of fuel to the accumulator tank. Since the
25 pump means work at a relatively high frequency, it is not possible to reset the constriction of the regulating valve each time when fuel is supplied to the respective pump means. The regulating valve therefore delivers a substantially equal fuel flow to each pump means. In situations where the load on the combustion engine is low, a reduced amount of fuel is supplied to the respective pump means. Thus only a small
30 proportion of the stroke length of the pistons of the respective pump means is usable for compressing the fuel. Consequently the fuel pump will work at reduced efficiency when the load upon it is low. Moreover, the pump means will emit more noise when

the load upon them is low. The reason for the increased noise emissions is that the pump means are not totally full of fuel during the compression stroke of the pistons.

SUMMARY OF THE INVENTION

5

The object of the present invention is to provide a fuel pump and a method for controlling a fuel pump whereby fuel can with very good accuracy be delivered to the respective pump means of the fuel pump in a relatively simple manner. Other objects are that the fuel pump should have good efficiency and emit little noise substantially
10 irrespective of the amount of fuel pressurised by the fuel pump.

The objects indicated above are achieved with the fuel pump of the kind mentioned in the introduction which is characterised by the features indicated in the characterising part of claim 1. On the basis inter alia of knowing the prevailing fuel pressure in a fuel
15 source, the control unit can calculate how long the valve needs to be kept in the open position to allow a desired amount of fuel to be supplied to the respective pump means. Valves which are only settable in an open position and a closed position can usually be switched very quickly between said positions. Valve opening time can thus be controlled with good accuracy and hence also the amount of fuel which is supplied to
20 the respective pump means. Such valve control thus allows individual control of the amount of fuel delivered each time to the respective pump means. The efficiency of a pump means and its noise emissions depend on the amount of fuel delivered to it. Such individual control of the amount of fuel delivered to the respective pump means allows the total amount of fuel to be distributed among the respective pump means in
25 such a way that the fuel pump achieves overall a substantially optimum good efficiency and substantially optimum low noise emissions with the amount of fuel pressurised by the fuel pump.

According to an embodiment of the present invention, the control unit is adapted to
30 controlling the valve so that it leads a maximum amount of fuel to one pump means and a remaining amount of fuel to the other pump means in operating situations where the fuel pump is adapted to delivering an amount of fuel which exceeds the capacity of

one of the pump means. By filling at least one pump means completely with fuel and the other with a remaining amount of fuel, the fuel pump works overall at higher efficiency than if the two pump means are provided with equal distribution of fuel. Noise emissions from the fuel pump are also reduced by such distribution of the

5 amount of fuel between the pump means as compared with equal distribution. With advantage, the control unit is adapted to controlling the valve so that it only leads fuel to one pump means in operating situations where the fuel pump is adapted to delivering an amount of fuel which corresponds to or is below the capacity of one of the pump means. One pump means is thus filled completely or partly with fuel, while

10 no fuel is led to the other pump means. Here again the fuel pump will operate with higher efficiency and lower noise emissions than if the fuel was distributed equally between the pump means.

According to another embodiment of the present invention, the control unit is adapted

15 to using knowledge of the performance of the respective pump means to opt to supply fuel primarily to the pump means which has the best performance. The pump means of a high-pressure pump are subject to severe stresses. The pump means are subject during operation to wear which progressively reduces their performance, but the wear of each pump means is individual, with the result that the performance of the pump

20 means usually differs after a period of use. The service life of the fuel pump can be lengthened by using primarily the pump means which has the best performance, i.e. the least worn pump means. The control unit may accordingly be adapted to receiving information from a pressure sensor concerning the pressure imparted to the fuel by the respective pump means, and to supplying fuel primarily to the pump means which

25 imparts the greatest pressure to the fuel. In situations where the fuel is supplied to an accumulator tank ("common rail"), the existing pressure sensor may here be used for determining the fuel pressure in the accumulator tank at the times when the respective pump means deliver pressurised fuel to the accumulator tank.

30 According to another embodiment of the present invention, the pump means are of substantially identical configuration and are run at a mutual phase displacement that enables them to pressurise fuel in their respective spaces during different periods of

time. Using substantially identical pump means makes it possible for the fuel pump to pressurise fuel to a corresponding pressure and in a corresponding quantity irrespective of which pump means is used. Pump means pressurising fuel during different periods of time makes it possible for fuel from one pump means at a time to be led to, for
5 example, an accumulator tank. With advantage, the pump means are operated at a mutual phase displacement of 180° in a work cycle of 360° . Thus one pump means pressurises fuel while at the same time the other pump means receives fuel. The fuel pump may of course comprise more than two pump means run at suitable phase displacements.

10

According to another embodiment of the present invention, said pressure-generating means is a piston. A piston which has a relatively small contact surface with the fuel in the respective spaces of the pump means can with advantage be used for creating very high fuel pressure in the spaces. Said fuel source preferably contains fuel at a
15 substantially constant pressure, making it relatively easy for the control unit to calculate the time for which the valve needs to be placed in the open position to allow a desired amount of fuel to be supplied to a pump means. The valve may be a solenoid valve. Solenoid valves have the characteristic of being switchable very quickly between a closed position and an open position. It is nevertheless also possible to use
20 other types of valves which are only settable in a closed position and an open position.

BRIEF DESCRIPTION OF THE DRAWINGS

A preferred embodiment of the invention is described below by way of example with
25 reference to the attached drawings, in which:

Fig. 1 depicts an injection system with a fuel pump according to the present invention and

Fig. 2 depicts the fuel pump in Fig. 1 in more detail.

30

DETAILED DESCRIPTION OF A PREFERRED EMBODIMENT OF THE INVENTION

Fig. 1 depicts an injection system for injecting fuel at a very high pressure in a combustion engine here exemplified as a diesel engine 1. Injecting the fuel at a very high pressure may reduce discharges of emissions from the diesel engine 1. The injection system and the diesel engine 1 may be fitted in a heavy vehicle. The injection system comprises a fuel line 2 for supplying fuel from a fuel tank 3 to the respective cylinders of the diesel engine 1. A first fuel pump 4 is arranged in the fuel line 2 to transfer fuel from the fuel tank 3 to a second fuel pump in the form of a high-pressure pump 6 via a filter 5. The high-pressure pump 6 is adapted to pressurising the fuel so that it is fed at a high pressure into an accumulator tank 7 which takes the form of a so-called "common rail". Injection means 8 are arranged at each of the connections between the accumulator tank 7 and the respective cylinders of the diesel engine 1. A return line 9 is adapted to leading fuel not burnt in the diesel engine 1 back to the fuel tank 3. In cases where fuel is also used for controlling the opening times of the injection means 8, such a return flow may be relatively abundant. An electrical control unit 10 is intended to control the operation of the fuel pump 4, the high-pressure pump 6 and the injection means 8. The electrical control unit 10 may take the form of a computer unit provided with suitable software for effecting such control. A pressure sensor 7a is fitted in the accumulator tank 7 to detect the prevailing pressure therein and send to the control unit 10 a signal conveying information about pressure values detected. On the basis inter alia of that information the control unit 10 can control the injection means 8 so that they inject an optimum amount of fuel at an optimum time in the respective cylinders of the diesel engine 1.

Fig. 2 depicts the high-pressure pump 6 in more detail. The high-pressure pump 6 comprises a first pump means 6a and a second pump means 6b. The pump means 6a, b are of substantially identical construction. The control unit 10 is intended to control a solenoid valve 11 by means of an electrical signal via a line 12 in order to regulate the supply of fuel from the fuel line 2 to the two pump means 6a, b. The solenoid valve 11 is only settable in an open position and a closed position. The pump means 6a, b each have their respective space 13a, b for receiving fuel. An inlet passage 14 is adapted to leading fuel from the solenoid valve 11 to the respective spaces 13a, b of

the pump means. The inlet passage 14 is connected to the respective spaces 13a, b via inlet valves 15a, b. The inlet valves 15a, b are check valves adapted to opening when the fuel pressure in the inlet passage 14 exceeds the fuel pressure in the respective spaces 13a, b. An outlet passage 16 is adapted to leading pressurised fuel out from the
5 respective spaces 13a, b. The outlet passage 16 is connected to the respective spaces 13a, b via outlet valves 17a, b. The outlet valves 17a, b are check valves adapted to opening when the fuel pressure in the respective spaces 13a, b exceeds a predetermined pressure P_2 . The pressure delivered to the accumulator tank 7 will thus be at least the pressure P_2 .

10

Each of the pump means 6a, b comprises a cylindrical space 18a, b with a movable piston 19a, b. The pistons 19a, b each have a pressure-generating surface which constitutes a delineating surface of the respective space 13a, b. The spaces 13a, b thus comprise a variable portion of the cylindrical spaces 18a, b, depending on the positions
15 of the pistons 19a, b in the respective cylindrical spaces 18a, b. Each of the pistons 19a, b has a lower end which is in contact with a respective component 20a, b which comprises a rolling means 21a, b. The rolling means 21a, b is adapted to rolling along a respective cam surface 22a, b of a rotatable shaft 23. Spring means 24a, b are adapted to ensuring that the respective rolling means 21a, b are kept in continuous
20 contact with their respective cam surface 22a, b. The cam surfaces 22a, b are of substantially identical shape but at a mutual displacement of 180° . Accordingly, the pistons 19a, b of the respective pump means 6a, b will move in opposite directions during operation of the shaft 23. A working cycle of the high-pressure fuel pump 6 may thus be divided into a first period of time and a second period of time. During the
25 first period the piston 19a of the first pump means moves upwards so that fuel in the space 13a is pressurised while at the same time the piston 19b of the second pump means moves downwards so that fuel can be supplied to the space 13b. During the second period, the piston 19a of the first pump means moves downwards so that fuel can be supplied to the space 13a while at the same time the piston 19b of the second
30 pump means moves upwards so that fuel in the space 13b is pressurised. The high-pressure pump 6 comprises a housing 25 which encloses the aforesaid components. The cylindrical spaces 18a, b comprise at one location a circular hollow space for

intercepting any leaking fuel in the clearance between the pistons 19a, b and the cylindrical spaces 18a, b. The leaking fuel is led back to the fuel tank 3 via a line 26 and the return line 9.

- 5 During operation of the high-pressure pump 6, the control unit 10 receives information from various parameters related to the operation of the combustion engine 1. On the basis of that information and information from the pressure sensor 7b concerning the prevailing pressure in the accumulator tank 7, the control unit 10 calculates the total amount of fuel which the pump means 6a, b need to supply to the accumulator tank 7.
- 10 The control unit 10 calculates thereafter the time for which the solenoid valve 11 needs to be kept in the open position for the respective pump means 6a, b so as to provide an optimum distribution of the total amount of fuel to the respective pump means 6a, b. When the solenoid valve 11 is open, fuel is led into the inlet passage 14 at a first pressure P_1 imparted to the fuel by the first fuel pump 4. The first pressure P_1 is higher
- 15 than the pressure prevailing in the space 13a, b when the piston 19a, b moves downwards, and lower than the pressure P_2 which prevails in the space 13a, b when the piston 19a, b moves upwards. Thus the fuel in the inlet passage 14 can only be led into one of the spaces 13a, b at a time. The fuel is thus led in the space 13a, b in which the piston 19a, b moves downwards. When thereafter this piston 19a, b turns and
- 20 moves upwards, it pressurises the fuel in the space 13a, b. When the pressure in the space 13a, b reaches a predetermined value P_2 , the outlet valve 17a, b opens. Fuel at at least the pressure P_2 flows out from the space 13a, b and is led via the outlet passage 16 to the accumulator tank 7.
- 25 When the load on the combustion engine 1 is high, a substantially maximum amount of fuel needs to be supplied to the accumulator tank 7. In this situation the control unit 10 keeps the solenoid valve 11 open for a calculated time during said first period and said second period so that both of the spaces 13a, b of the respective pump means are filled with a maximum amount of fuel. In this operating situation, the resulting
- 30 optimum use of the stroke lengths of the pistons 19a, b allows the fuel pump 6 to operate at high efficiency, and the fact that the spaces 13a, b are completely full of fuel during the stroke movements of the pistons 19a, b results in low noise emissions. In

certain operating situations, however, the fuel pump 6 is adapted to delivering smaller amounts of fuel to the accumulator tank 7. When such a reduced amount of fuel exceeds the capacity of a pump means 6a, b, the control unit 10 causes the solenoid valve 11 to stay open long enough for a maximum amount of fuel to be led to one pump means 6a, b. The control unit 10 thereafter causes the solenoid valve 11 to stay open for a shorter time to enable a remaining amount of fuel to be led to the second pump means 6a, b. This method of filling one pump means 6a, b completely with fuel and the other pump means 6a, b with the remaining amount of fuel results in overall higher efficiency of the fuel pump 6 than if the two pump means 6a, b are filled equally with fuel. Noise emissions from the fuel pump 6 are also reduced by such distribution of the amount of fuel between the pump means 6a, b as compared with the fuel being distributed equally between the pump means 6a, b. In certain operating situations, the high-pressure pump 6 is adapted to delivering a small amount of fuel corresponding to or below the capacity of a single pump means 6a, b, in which case the control unit 10 is adapted to keeping the solenoid valve 11 in an open position long enough for said amount of fuel to be delivered to one of the pump means 6a, b. In this situation, the control unit 10 does not open the solenoid valve 11 at all during the period when the second pump means 6a, b might become filled with fuel. Here again, the high-pressure pump 6 runs at higher efficiency and emits less noise than if the fuel was distributed equally between the pump means 6a, b.

During operation, the pump means 6a, b inevitably undergo wear which progressively reduces their respective performance. The overall service life of the fuel pump 6 is lengthened by primarily using the pump means 6a, b which at the time has the best performance, i.e. the least worn pump means. The control unit 10 is adapted accordingly to receiving information from a pressure sensor 7a which detects the fuel pressure in the accumulator tank 7. Since the respective pump means 6a, b deliver pressurised fuel to the accumulator tank at different times, the control unit 10 can register the pressure which each pump means 6a, b is able to impart to the pressurised fuel in the accumulator tank 7. This pressure is a parameter related to the performance of the pump means 6a, b. On the basis of this information, the control unit 10 can primarily supply fuel to the pump means 6a, b which has the best performance in

operating situations where the fuel pump 6 supplies a reduced amount of fuel. The result is optimum pressure in the accumulator tank 7 in such situations and longer service life for the high-pressure pump 6.

- 5 The invention is in no way limited to the embodiment described above but may be varied within the scopes of the claims. The high-pressure pump may comprise more than two pump means. The pump means may be operated at a suitable phase displacement so as to allow individual supply of fuel to the respective pump means.

Claims

1. A fuel pump which comprises at least two pump means (6a, b) each having a space (13a, b) for receiving fuel, a valve (11) adapted to regulating the amount of fuel led
5 from a fuel source (2) to the recesses (13a, b) of the pump means, pressure-generating means (19a, b) adapted to pressurising the fuel in said spaces (13a, b), and a control unit (10) adapted to controlling the valve (11) in such a way that a desired amount of fuel is led to the recesses (13a, b) of the pump means, which pump means (6a, b) are run at a mutual phase displacement such that they are able to receive fuel in their
10 respective spaces (13a, b) during different periods of time, characterised in that the valve (11) is only settable in an open position and a closed position and that the control unit (10) is adapted to placing the valve (11) in the open position for a variable portion of said periods so that an individually controlled amount of fuel is led from the fuel source (2) to the spaces (13a, b) of the respective pump means during said periods.
15
2. A fuel pump according to claim 1, characterised in that the control unit (10) is adapted to causing the valve (11) to lead a maximum amount of fuel to one pump means (6a, b) and the remaining amount of fuel to the other pump means (6a, b) in operating situations where the fuel pump is adapted to delivering an amount of fuel
20 which exceeds the capacity of one of the pump means (6a, b).
3. A fuel pump according to claim 1 or 2, characterised in that the control unit (10) is adapted to causing the valve (11) to lead fuel to only one pump means (6a, b) in operating situations where the fuel pump is adapted to delivering an amount of fuel
25 which corresponds to or is below the capacity of one of the pump means (6a, b).
4. A fuel pump according to any one of the foregoing claims, characterised in that the control unit (10) is adapted to using knowledge of the performance of the respective pump means (6a, b) as a basis for opting to supply fuel primarily to the pump means
30 (6a, b) which has the best performance.

5. A fuel pump according to claim 4, characterised in that the control unit (10) is adapted to receiving information from a pressure sensor (7a) concerning the pressure imparted to the fuel by each pump means (6a, b), and to supplying fuel primarily to the pump means (6a, b) which imparts the greatest pressure to the fuel.
- 5
6. A fuel pump according to any one of the foregoing claims, characterised in that the pump means (6a, b) are of substantially identical configuration and that they are run at a mutual phase displacement such that they are able to pressurise fuel in their respective spaces (13a, b) during different periods of time.
- 10
7. A fuel pump according to claim 6, characterised in that the pump means (6a, b) are run at a mutual phase displacement of 180° in a working cycle of 360° .
8. A fuel pump according to any one of the foregoing claims, characterised in that said
- 15 pressure-generating means is a piston (19a, b).
9. A fuel pump according to any one of the foregoing claims, characterised in that said fuel source (2) contains fuel at a substantially constant pressure (P_1).
- 20
10. A fuel pump according to any one of the foregoing claims, characterised in that the valve is a solenoid valve (11).
11. A method for controlling a fuel pump, which fuel pump comprises at least two pump means (6a, b) each having a space (13a, b) for receiving fuel, a valve (11) which
- 25 is only settable in an open and a closed position to regulate the amount of fuel led from a fuel source (2) to the recesses (13a, b) of the pump means, pressure-generating means (19a, b) adapted to pressurising the fuel in said spaces (13a, b), and a control unit (10) adapted to controlling the valve (11) in such a way that a desired amount of fuel is led to the recesses (13a, b) of the pump means, characterised by the steps of
- 30 running the pump means (6a, b) at a mutual phase displacement such that they are able to receive fuel in their respective spaces (13a, b) during different periods of time, and of placing the valve (11) in the open position for a variable portion of said periods so

that an individually controlled amount of fuel is led from the fuel source (2) to the spaces (13a, b) of the respective pump means during said periods.

12. A method according to claim 11, characterised by the step of causing the valve (11) to lead a maximum amount of fuel to one pump means (6a, b) and the remaining amount of fuel to the other pump means (6a, b) in operating situations where the fuel pump is adapted to delivering an amount of fuel which exceeds the capacity of one of the pump means (6a, b).
- 10 13. A method according to claim 11 or 12, characterised by the step of causing the valve (11) to lead fuel to only one pump means (6a, b) in operating situations where the fuel pump is adapted to delivering an amount of fuel which corresponds to or is below the capacity of one of the pump means (6a, b).
- 15 14. A method according to any one of claims 11-13 above, characterised by the step of using knowledge of the performance of the respective pump means (6a, b) as a basis for opting to supply fuel primarily to the pump means (6a, b) which has the best performance.
- 20 15. A method according to claim 14, characterised by the step of receiving information from a pressure sensor (7a) concerning the pressure imparted to the fuel by each pump means (6a, b), and to supplying fuel primarily to the pump means (6a, b) which imparts the greatest pressure to the fuel.
- 25 16. A method according to any one of claims 11-15 above, characterised by the steps of using pump means (6a, b) which are of substantially identical configuration, and of running the pump means (6a, b) at a mutual phase displacement such that they are able to pressurise fuel in their respective spaces (13a, b) during different periods of time.
- 30 17. A method according to claim 16, characterised by the step of running the pump means (6a, b) at a mutual phase displacement of 180° in a working cycle of 360° .

18. A method according to any one of claims 11-17 above, characterised by the step of using a piston (19a, b) for pressurising the fuel in said spaces (13a, b).
19. A method according to any one of the foregoing claims, characterised by the step
5 of using a fuel source (2) which contains fuel at a substantially constant pressure (P_1).
20. A method according to any one of the foregoing claims, characterised by the step of using a solenoid valve (11) for regulating the amount of fuel which is led from a fuel source (2) to the recesses (13a, b) of the pump means.

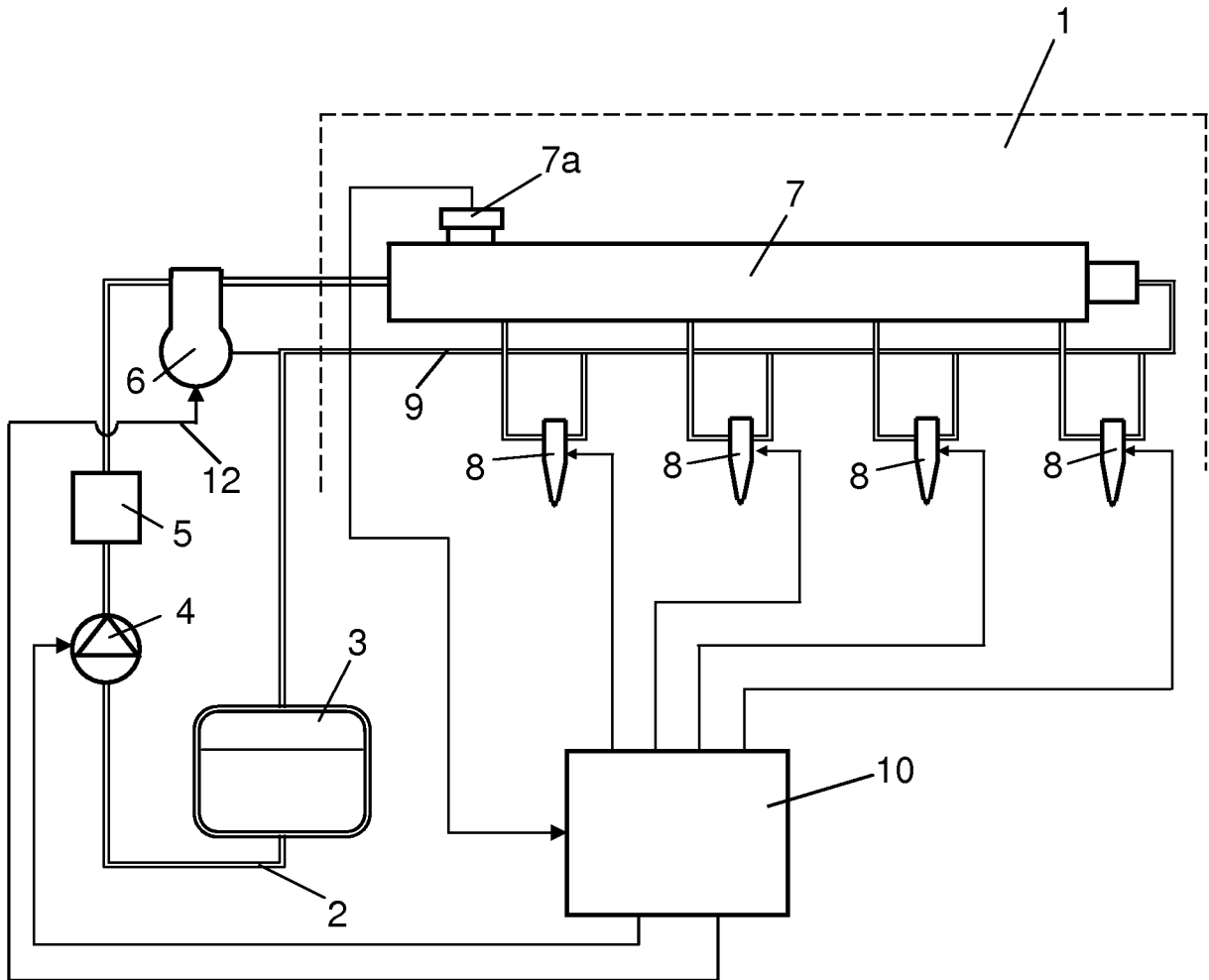

Fig 1

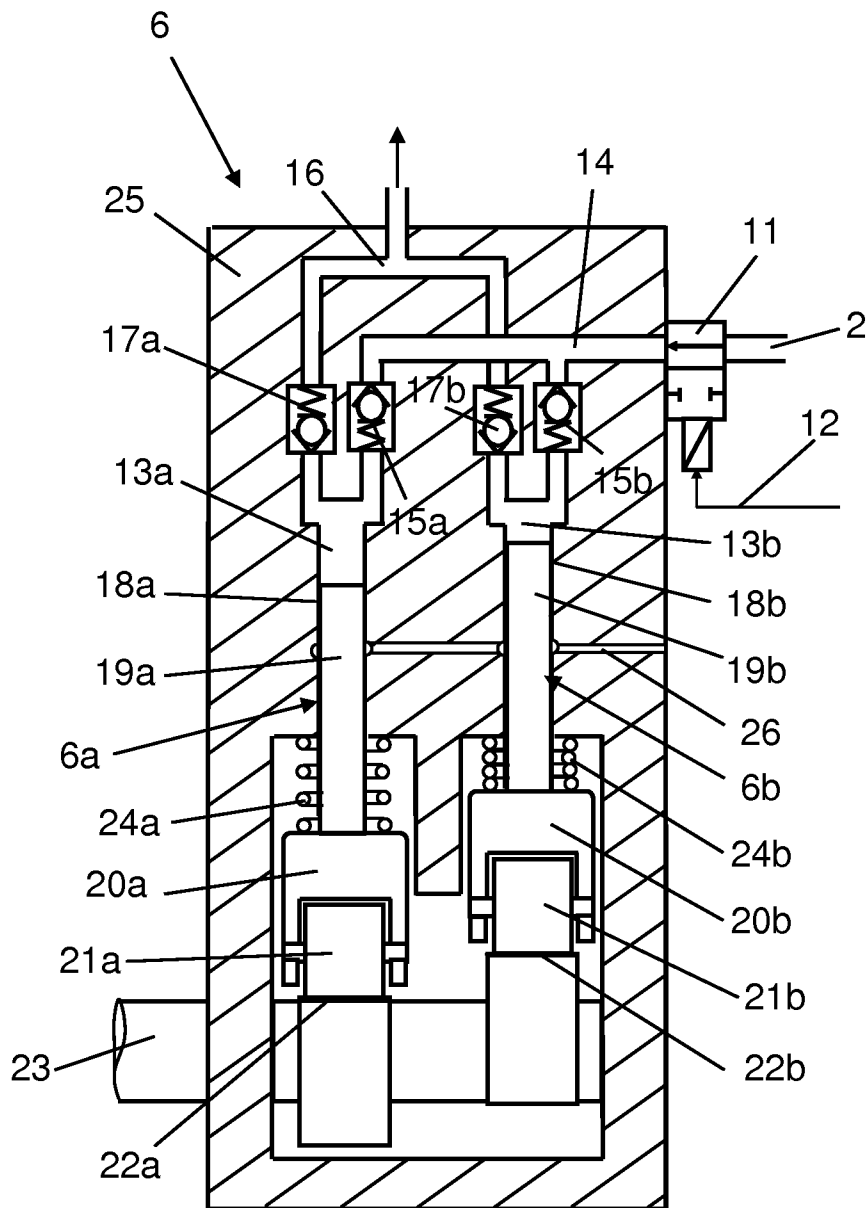

Fig 2

INTERNATIONAL SEARCH REPORT

International application No.
PCT/SE2007/050992

<p>A. CLASSIFICATION OF SUBJECT MATTER</p> <p>IPC: see extra sheet According to International Patent Classification (IPC) or to both national classification and IPC</p>																	
<p>B. FIELDS SEARCHED</p> <p>Minimum documentation searched (classification system followed by classification symbols)</p> <p>IPC: F02M</p> <p>Documentation searched other than minimum documentation to the extent that such documents are included in the fields searched</p> <p>SE,DK,FI,NO classes as above</p> <p>Electronic data base consulted during the international search (name of data base and, where practicable, search terms used)</p> <p>EPO-INTERNAL, WPI DATA, PAJ</p>																	
<p>C. DOCUMENTS CONSIDERED TO BE RELEVANT</p> <table border="1"> <thead> <tr> <th>Category*</th> <th>Citation of document, with indication, where appropriate, of the relevant passages</th> <th>Relevant to claim No.</th> </tr> </thead> <tbody> <tr> <td>A</td> <td>EP 1429020 A1 (CATERPILLAR INC.), 16 June 2004 (16.06.2004), figures 1-5, abstract --</td> <td></td> </tr> <tr> <td>A</td> <td>US 5404855 A (YEN ET AL), 11 April 1995 (11.04.1995), figures 1-6, abstract --</td> <td></td> </tr> <tr> <td>A</td> <td>US 4459963 A (GROSS ET AL), 17 July 1984 (17.07.1984), figures 1-8, abstract --</td> <td></td> </tr> <tr> <td>A</td> <td>US 20060120880 A1 (SHAFER ET AL), 8 June 2006 (08.06.2006), figures 1-3, abstract -- -----</td> <td></td> </tr> </tbody> </table>			Category*	Citation of document, with indication, where appropriate, of the relevant passages	Relevant to claim No.	A	EP 1429020 A1 (CATERPILLAR INC.), 16 June 2004 (16.06.2004), figures 1-5, abstract --		A	US 5404855 A (YEN ET AL), 11 April 1995 (11.04.1995), figures 1-6, abstract --		A	US 4459963 A (GROSS ET AL), 17 July 1984 (17.07.1984), figures 1-8, abstract --		A	US 20060120880 A1 (SHAFER ET AL), 8 June 2006 (08.06.2006), figures 1-3, abstract -- -----	
Category*	Citation of document, with indication, where appropriate, of the relevant passages	Relevant to claim No.															
A	EP 1429020 A1 (CATERPILLAR INC.), 16 June 2004 (16.06.2004), figures 1-5, abstract --																
A	US 5404855 A (YEN ET AL), 11 April 1995 (11.04.1995), figures 1-6, abstract --																
A	US 4459963 A (GROSS ET AL), 17 July 1984 (17.07.1984), figures 1-8, abstract --																
A	US 20060120880 A1 (SHAFER ET AL), 8 June 2006 (08.06.2006), figures 1-3, abstract -- -----																
<p><input type="checkbox"/> Further documents are listed in the continuation of Box C. <input checked="" type="checkbox"/> See patent family annex.</p>																	
<p>* Special categories of cited documents:</p> <table border="0"> <tr> <td>"A" document defining the general state of the art which is not considered to be of particular relevance</td> <td>"T" later document published after the international filing date or priority date and not in conflict with the application but cited to understand the principle or theory underlying the invention</td> </tr> <tr> <td>"E" earlier application or patent but published on or after the international filing date</td> <td>"X" document of particular relevance: the claimed invention cannot be considered novel or cannot be considered to involve an inventive step when the document is taken alone</td> </tr> <tr> <td>"L" document which may throw doubts on priority claim(s) or which is cited to establish the publication date of another citation or other special reason (as specified)</td> <td>"Y" document of particular relevance: the claimed invention cannot be considered to involve an inventive step when the document is combined with one or more other such documents, such combination being obvious to a person skilled in the art</td> </tr> <tr> <td>"O" document referring to an oral disclosure, use, exhibition or other means</td> <td>"&" document member of the same patent family</td> </tr> <tr> <td>"P" document published prior to the international filing date but later than the priority date claimed</td> <td></td> </tr> </table>			"A" document defining the general state of the art which is not considered to be of particular relevance	"T" later document published after the international filing date or priority date and not in conflict with the application but cited to understand the principle or theory underlying the invention	"E" earlier application or patent but published on or after the international filing date	"X" document of particular relevance: the claimed invention cannot be considered novel or cannot be considered to involve an inventive step when the document is taken alone	"L" document which may throw doubts on priority claim(s) or which is cited to establish the publication date of another citation or other special reason (as specified)	"Y" document of particular relevance: the claimed invention cannot be considered to involve an inventive step when the document is combined with one or more other such documents, such combination being obvious to a person skilled in the art	"O" document referring to an oral disclosure, use, exhibition or other means	"&" document member of the same patent family	"P" document published prior to the international filing date but later than the priority date claimed						
"A" document defining the general state of the art which is not considered to be of particular relevance	"T" later document published after the international filing date or priority date and not in conflict with the application but cited to understand the principle or theory underlying the invention																
"E" earlier application or patent but published on or after the international filing date	"X" document of particular relevance: the claimed invention cannot be considered novel or cannot be considered to involve an inventive step when the document is taken alone																
"L" document which may throw doubts on priority claim(s) or which is cited to establish the publication date of another citation or other special reason (as specified)	"Y" document of particular relevance: the claimed invention cannot be considered to involve an inventive step when the document is combined with one or more other such documents, such combination being obvious to a person skilled in the art																
"O" document referring to an oral disclosure, use, exhibition or other means	"&" document member of the same patent family																
"P" document published prior to the international filing date but later than the priority date claimed																	
<p>Date of the actual completion of the international search</p> <p>29 April 2008</p>		<p>Date of mailing of the international search report</p> <p>29-04-2008</p>															
<p>Name and mailing address of the ISA/ Swedish Patent Office Box 5055, S-102 42 STOCKHOLM Facsimile No. +46 8 666 02 86</p>		<p>Authorized officer</p> <p>Dan Ionesco / JA A Telephone No. +46 8 782 25 00</p>															

INTERNATIONAL SEARCH REPORT

International application No.
PCT/SE2007/050992

International patent classification (IPC)

F02M 59/08 (2006.01)

F02M 63/02 (2006.01)

Download your patent documents at www.prv.se

The cited patent documents can be downloaded at www.prv.se by following the links:

- In English/Searches and advisory services/Cited documents (service in English) or
- e-tjänster/anförda dokument (service in Swedish).

Use the application number as username.

The password is **ZHBXJEKJGZ**.

Paper copies can be ordered at a cost of 50 SEK per copy from PRV InterPat (telephone number 08-782 28 85).

Cited literature, if any, will be enclosed in paper form.

INTERNATIONAL SEARCH REPORT

International application No.

26/01/2008

PCT/SE2007/050992

EP	1429020	A1	16/06/2004	US	7179060	B	20/02/2007
				US	20040109768	A	10/06/2004
				US	20070086899	A	19/04/2007

US	5404855	A	11/04/1995	AT	178973	T	15/04/1999
				AU	6785994	A	12/12/1994
				AU	6945894	A	12/12/1994
				BR	9405350	A	31/08/1999
				CN	1055745	B,C	23/08/2000
				CN	1111065	A	01/11/1995
				DE	69417846	D,T	12/08/1999
				EP	0654122	A,B	24/05/1995
				EP	0889233	A	07/01/1999
				GB	2284024	A,B	24/05/1995
				GB	9500014	D	00/00/0000
				JP	7509042	T	05/10/1995
				MX	9403372	A	31/01/1995
				WO	9427039	A	24/11/1994
				WO	9427041	A	24/11/1994

US	4459963	A	17/07/1984	AU	8163982	A	07/10/1982
				BR	8201744	A	22/02/1983
				DE	3112381	A,C	11/11/1982
				GB	2095768	A,B	06/10/1982
				JP	1725799	C	19/01/1993
				JP	4011738	B	02/03/1992
				JP	57173554	A	25/10/1982

US	20060120880	A1	08/06/2006	CN	1811158	A	02/08/2006
				DE	102005055319	A	27/07/2006
				GB	0524245	D	00/00/0000
				GB	2420600	A	31/05/2006
				JP	2006153017	A	15/06/2006
