



## INTERNATIONAL APPLICATION PUBLISHED UNDER THE PATENT COOPERATION TREATY (PCT)

<p>(51) International Patent Classification <sup>6</sup> : <b>B65D 85/04, B65H 49/02</b></p>	<p><b>A1</b></p>	<p>(11) International Publication Number: <b>WO 98/52844</b></p> <p>(43) International Publication Date: 26 November 1998 (26.11.98)</p>
<p>(21) International Application Number: PCT/SE97/00816</p> <p>(22) International Filing Date: 20 May 1997 (20.05.97)</p> <p>(71) Applicant (for all designated States except US): ESAB AB [SE/SE]; P.O. Box 8004, S-402 77 Göteborg (SE).</p> <p>(72) Inventors; and</p> <p>(75) Inventors/Applicants (for US only): B-JENSEN, Bernt-Inge [SE/SE]; Rexegatan 3, S-442 32 Kungälv (SE). CARLSSON, Gilbert [SE/SE]; Tegelbruksgatan 57, S-441 56 Alingsås (SE).</p> <p>(74) Agent: AWAPATENT AB; P.O. Box 11394, S-404 28 Göteborg (SE).</p>	<p>(81) Designated States: AL, AM, AT, AU, AZ, BA, BB, BG, BR, BY, CA, CH, CN, CU, CZ, DE, DK, EE, ES, FI, GB, GE, GH, HU, IL, IS, JP, KE, KG, KP, KR, KZ, LC, LK, LR, LS, LT, LU, LV, MD, MG, MK, MN, MW, MX, NO, NZ, PL, PT, RO, RU, SD, SE, SG, SI, SK, TJ, TM, TR, TT, UA, UG, US, UZ, VN, YU, ARIPO patent (GH, KE, LS, MW, SD, SZ, UG), Eurasian patent (AM, AZ, BY, KG, KZ, MD, RU, TJ, TM), European patent (AT, BE, CH, DE, DK, ES, FI, FR, GB, GR, IE, IT, LU, MC, NL, PT, SE), OAPI patent (BF, BJ, CF, CG, CI, CM, GA, GN, ML, MR, NE, SN, TD, TG).</p> <p><b>Published</b> With international search report.</p>	

(54) Title: CONTAINER FOR PACKAGING AND UNWINDING A COIL OF WELDING WIRE

## (57) Abstract

The invention concerns a container (1) for packaging and unwinding a coil of welding wire, which comprises a box-like body (4) having inner walls (5b) forming a polygonal periphery for accommodating a circular coil (2) of wire (3) during the transportation and the unwinding of the coil (2). The container also comprises a cover (6) at the upper end of the body (4), a bottom (26) at the lower end of the body, a retainer device (17) arranged inside the body on the coil for preventing accidental entanglement of the wire turns during the unwinding of the wire from the coil, and a wire conduit device (10) for the guidance of the wire out from the body during the unwinding. At least in some places the retainer device (17) is in contact with the inner walls of the body, especially during the unwinding. The cover (6) is flat and is placed at the top of the body both during the transportation and the unwinding of the wire (3). The wire conduit device (10) is attached to the cover during the unwinding.

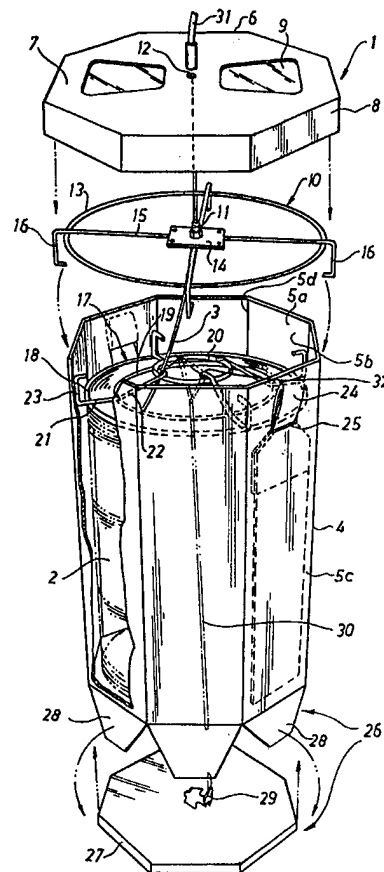

**FOR THE PURPOSES OF INFORMATION ONLY**

Codes used to identify States party to the PCT on the front pages of pamphlets publishing international applications under the PCT.

<b>AL</b>	Albania	<b>ES</b>	Spain	<b>LS</b>	Lesotho	<b>SI</b>	Slovenia
<b>AM</b>	Armenia	<b>FI</b>	Finland	<b>LT</b>	Lithuania	<b>SK</b>	Slovakia
<b>AT</b>	Austria	<b>FR</b>	France	<b>LU</b>	Luxembourg	<b>SN</b>	Senegal
<b>AU</b>	Australia	<b>GA</b>	Gabon	<b>LV</b>	Latvia	<b>SZ</b>	Swaziland
<b>AZ</b>	Azerbaijan	<b>GB</b>	United Kingdom	<b>MC</b>	Monaco	<b>TD</b>	Chad
<b>BA</b>	Bosnia and Herzegovina	<b>GE</b>	Georgia	<b>MD</b>	Republic of Moldova	<b>TG</b>	Togo
<b>BB</b>	Barbados	<b>GH</b>	Ghana	<b>MG</b>	Madagascar	<b>TJ</b>	Tajikistan
<b>BE</b>	Belgium	<b>GN</b>	Guinea	<b>MK</b>	The former Yugoslav Republic of Macedonia	<b>TM</b>	Turkmenistan
<b>BF</b>	Burkina Faso	<b>GR</b>	Greece	<b>ML</b>	Mali	<b>TR</b>	Turkey
<b>BG</b>	Bulgaria	<b>HU</b>	Hungary	<b>MN</b>	Mongolia	<b>TT</b>	Trinidad and Tobago
<b>BJ</b>	Benin	<b>IE</b>	Ireland	<b>MR</b>	Mauritania	<b>UA</b>	Ukraine
<b>BR</b>	Brazil	<b>IL</b>	Israel	<b>MW</b>	Malawi	<b>UG</b>	Uganda
<b>BY</b>	Belarus	<b>IS</b>	Iceland	<b>MX</b>	Mexico	<b>US</b>	United States of America
<b>CA</b>	Canada	<b>IT</b>	Italy	<b>NE</b>	Niger	<b>UZ</b>	Uzbekistan
<b>CF</b>	Central African Republic	<b>JP</b>	Japan	<b>NL</b>	Netherlands	<b>VN</b>	Viet Nam
<b>CG</b>	Congo	<b>KE</b>	Kenya	<b>NO</b>	Norway	<b>YU</b>	Yugoslavia
<b>CH</b>	Switzerland	<b>KG</b>	Kyrgyzstan	<b>NZ</b>	New Zealand	<b>ZW</b>	Zimbabwe
<b>CI</b>	Côte d'Ivoire	<b>KP</b>	Democratic People's Republic of Korea	<b>PL</b>	Poland		
<b>CM</b>	Cameroon	<b>KR</b>	Republic of Korea	<b>PT</b>	Portugal		
<b>CN</b>	China	<b>KZ</b>	Kazakstan	<b>RO</b>	Romania		
<b>CU</b>	Cuba	<b>LC</b>	Saint Lucia	<b>RU</b>	Russian Federation		
<b>CZ</b>	Czech Republic	<b>LI</b>	Liechtenstein	<b>SD</b>	Sudan		
<b>DE</b>	Germany	<b>LK</b>	Sri Lanka	<b>SE</b>	Sweden		
<b>DK</b>	Denmark	<b>LR</b>	Liberia	<b>SG</b>	Singapore		
<b>EE</b>	Estonia						

CONTAINER FOR PACKAGING AND UNWINDING A COIL OF WELDING  
WIRE

The present invention relates to a container for packaging and unwinding a coil of welding wire, which comprises a box-like body having side panels forming a polygonal periphery for accommodating a circular coil of wire during the transportation and the unwinding of the coil, a cover at the upper end of the body, a bottom at the lower end of the body, a retainer device arranged inside the body on the coil for preventing accidental entanglement of the wire turn during the unwinding of the wire from an upper end of the coil, and a wire conduit device for the guidance of the wire out from the body during the unwinding.

In the unwinding of welding wires from coils there is a problem of unwinding uniformly and uninterruptedly and possibly without forming bumps and without applying undesirable twists to the wire, which would lead to defects or in any case to reduction of the quality of the welding joints. In most cases today, a cylindrical container with a circular retainer device is used for this purpose. In for example EP-0 519 424 such a container is described. For preventing accidental entanglement of the wire turns during the unwinding of the wire the retainer device has an outer portion with an outer periphery fitting into the diameter of the inner wall of the container and an inner bell-mouthed portion defining an innermost wire extraction opening. The retainer device is placed on the top of the coil and has a smaller diameter than the internal diameter of the container so that it can freely descend in the container in contact with the coil as the height of said coil decreases as the wire is being unwound from the coil. This results in that a gap is created between the

retainer device and said inner wall through which gap the wire, unwound from the coil, can pass.

For solving this problem a container and a coil retainer panel with a polygonal plan shape are described in WO 94/19258. Since the coil still is circular this results in that the retainer panel comprises angular portions outside the coil for preventing lifting of wire turns between the peripheral region of the panel and the inner surface of said box-like body and thus accidental entanglement of the wire turns. Since the retainer device according to this international application has no inner bell-mouthed portion defining an innermost wire extraction opening but instead a flat extraction opening the friction-induced drag that is exerted against the wire as it is being withdrawn is increased. A retainer device in the form of a flat panel can also result in that more than one wire turn is extracted from the extraction opening at the same time.

Another problem with circular containers is that they must be transported to the factories for making wire coils in an assembled state. By using a container with a polygonal shape it is possible to assemble the container at the factories, which results in considerable savings in transport and storage space as well as in easy handling.

Another problem with the containers used today is that the covers placed on the containers during the extraction of the wire cannot be used during the transportation of the containers, see the patent applications mentioned above.

The object of the present invention is to provide a container that is easy to transport while at the same time accidental entanglement of turns during the unwinding of the wire is eliminated.

This object is obtained in accordance with the present invention by means of a container of the kind mentioned in the introduction and which container is

characterised in that the retainer device at least in some places is in contact with the inner walls of the side panels of the body, especially during the unwinding, that the cover is flat and is placed at the top of the  
5 body both during the transportation and the unwinding of the wire and in that the wire conduit device is arranged at the cover during the unwinding.

Due to the provision of a flat cover to which a wire conduit device is arranged the same cover can be used  
10 both during the transportation and the unwinding of the wire, which simplifies the handling of the container. Since the retainer device at least in some places is in contact with the body a smooth extraction without any entanglement of the wire is obtained.

15 In addition, the container in accordance with the present invention may be designed in the manner defined in the dependent claims.

The invention will be described in closer detail in the following with reference to the accompanying drawing  
20 illustrating an exploded view of a container according to the present invention.

The container 1 illustrated in the figure is intended to be used for packaging and unwinding a circular coil 2 of welding wire 3. The container  
25 comprises a box-like body 4 of e.g. cardboard having side panels 5a the inner walls 5b and outer walls 5c of which form a polygonal periphery, typically an octagonal one, for accommodating the coil 2 of wire. The container has a cover 6 which is placed on top of the container both  
30 during the transportation and the unwinding of the welding wire. The cover has a top panel 7 and side panels 8 forming the same polygonal periphery, in this case an octagonal periphery, as the body 4 but slightly larger so that it can be placed over the upper end of the body. The  
35 cover also has two inspection windows 9 for making it possible to inspect the progress of the unwinding of the coil 2 without having to remove the cover.

A wire conduit device 10 is arranged at the cover 6 and attached to the upper end of the body 4 during the unwinding of the wire and is usually not enclosed in the container during the transportation. The wire conduit device comprises a first member in the form of a nipple 11 which is adapted to be placed in a hole 12 in the cover 6. Said conduit device also comprises a second member having a circular portion 13 in the form of a metal wire ring in the middle of which a plate 14 is arranged for supporting the nipple 11. Said second member also comprises four elements 15 in the form of straight metal wires which are so placed on the ring 13 that they coincide in the middle of the plate 14 at right angles to each other. The elements 15 extend beyond the outer periphery of the ring 13 to the inner walls of the side panels 8 of the cover 6 in the transverse direction of the cover. The elements 15 are provided with hooks 16 at their outer ends. Each hook has a first part which is extending in the longitudinal direction of the cover and a second part extending in the transverse direction of the cover. Usually, the length of the first part of each hook is somewhat longer than the height of the side panels 8. The distance between the free ends of two opposite hooks 16 is less than the distance between the outer walls 5c of two opposite side panels 5a of the body 4. During the unwinding, the elements 15 and the ring 13 abut against the inside of the top panel 7 of the cover 6 for reinforcing the cover while the first parts of the hooks 16 abut against the inner walls of the side panels 8 and the free ends of the hooks 16 are pressed against the outer walls 5c of the body 4. This results in that the second member and thus the first member are clamped on the upper end of the body 4. Since the cover is reinforced by the ring 13 and the elements 15 it can be made of a weaker and thereby cheaper material.

The container 1 also comprises a retainer device 17 which is made of three metal wire rings 18, 19 and 20

having different diameters. The ring 18 has the largest diameter and the ring 19 is arranged within the ring 18 in the same horizontal plane and the rings are connected to each other by four straight metal wires 21 arranged equidistant from each other. The ring 20 has the smallest diameter and is arranged inside the ring 19 but at a higher level and is connected to the ring 19 by four straight metal wires 22 coinciding with the metal wires 21.

10 In this manner, the three rings 18, 19, 20 form an inner frustoconical part with a central circular wire extraction opening and an outer part having a flat circular portion, which is intended to be placed on the coil 2 both during the transportation of the container and the  
15 unwinding of the welding wire but having its outer periphery arranged at a distance from the inner walls (5b) of the side panels (5a) of the body (4). The metal wires 21 are extended at the outer end by hooks 23. Each hook 23 has a first part extending in the longitudinal direction  
20 of the body 4 and a second part extending in the transverse direction of the body. The distance between the first parts of two opposite hooks 23 being less than the distance between the inner walls 5b of two opposite side panels 5a of the body 4, but greater than the distance  
25 between two opposite connection lines 5d between adjacent inner walls 5b of the body. Hereby, during the unwinding of the welding wire, the first parts of the hooks 23 will abut against four different inner walls 5b of the side panels 5a of the body 4, preventing the lifting of turns  
30 of wire between the outermost ring 18 and the inner walls 5b of the body 4 and thus accidental entanglement of turns. The metal wires 22 are also extended by hooks 32 at their free ends. Since the diameter of the ring 20 is small, it will prevent that more than one turn of the  
35 wire at the time will pass through the wire extraction opening.

As appears from the figure the body 4 is provided with two handles 24. Each handle is made in the form of a long strip of cardboard which in the vicinity of one of its ends has a portion with a reduced width. The strip is  
5 folded in the middle of this portion and opposite sides of the strip are then fastened, e.g. by means of glue, at each other. Said portion is of course not glued. The folded strip is then fastened to one of the side panels 5a of the body 4 and as seen in the figure the strip  
10 extends almost along the whole inner wall of the actual side panel. The portion with reduced width that functions as the actual handle extends to the outside of the body through an opening 25 near the upper end of the side panel. The design of the handles results in very strong  
15 handles which makes it possible to support a container that is containing a coil of wire weighing up to approximately 300 kilos. A special supporting yoke, not shown in the figure, is used for supporting the container in the handles.

20 The container 1 also comprises a bottom 26 having a bottom panel 27 formed in the same polygonal shape as the body 4 but being slightly smaller to allow it to be arranged inside the lower end of the body. The lower end of the body is provided with eight tabs 28 that are  
25 fastened under the bottom panel 27 by means of glue for example. Hereby the tabs 28 also form a part of the bottom 26.

As appears from the figure a safety-anchor is punched out from a layer of the bottom panel 27 for  
30 securing the coil during the transportation by means of an elastic strap 30 that is connected both to the anchor 29 and two of the hooks 32 of the retainer device.

During the unwinding of the coil of wire an outer feeder tube 31 for a welding station is connected to the  
35 nipple 11 by means of, for example, a quick coupling.

Obviously, the invention is not limited to the embodiment described above but may be modified in a

variety of different ways within the scope of the dependent claims. For instance, the hooks 32 arranged at the free upper ends of the metal wires 22 can be removed and replaced by a bar lying over the innermost ring 20 of the  
5 retainer device during the transportation for securing the coil. For instance, the strip forming the handle could be made without a portion with a reduced width.

CLAIMS

1. A container (1) for packaging and unwinding a coil of welding wire (3), which comprises a box-like body (4) having side panels (5a) forming a polygonal periphery for accommodating a circular coil of wire during the transportation and the unwinding of the coil (2), a cover (6) at the upper end of the body (4), a bottom (26) at the lower end of the body, a retainer device (17) arranged inside the body on the coil for preventing accidental entanglement of the wire turns during the unwinding of the wire from the coil, and a wire conduit device (10) for the guidance of the wire out from the body during the unwinding, characterized in that the retainer device (17) is in contact with the inner walls (5b) of the side panels (5a) of the body (4), especially during the unwinding, that the cover (6) is flat and is placed at the top of the body both during the transportation and the unwinding of the wire (3) and in that the wire conduit device (10) is arranged at the cover during the unwinding.

2. A container as claimed in claim 1, characterized in that the wire conduit device (10) is attached to the cover (6) and/or the body (4).

3. A container as claimed in claim 1 or 2, characterized in that the cover (6) has a top panel (7) and side panels (8) forming the same polygonal periphery as the side panels (5a) of the body (4) but being slightly larger to allow the cover to be arranged over the upper end of the body.

4. A container as claimed in claims 1, 2 and 3 characterized in that the retainer device (17) comprises an inner frustoconical part (19, 20, 22) with a central circular wire extraction opening, an outer part having a circular portion (18, 19, 21) arranged on the coil (2) but having its outer periphery arranged at a distance from the inner walls (5b) of the side panels

(5a) of the body (4) and at least two elements (23) extending from said outer periphery to the inner walls of the body in the transverse direction of said body.

5 5. A container as claimed in claim 4, c h a r a c -  
t e r i z e d in that the side panels (5a) of the body  
(4) forms an octagonal periphery and in that four  
elements (23) are in contact with four different inner  
walls (5b) of the side panels (5a) during the unwinding.

10 6. A container according to any one of the preceding  
claims, c h a r a c t e r i z e d in that the wire con-  
duit device comprises a first member (11) arranged at the  
cover (6) for guiding the wire from the inside of the  
body to its outside.

15 7. A container as claimed in claim 6, c h a r a c -  
t e r i z e d in that said first member is in the form of  
a nipple (11) which is adapted to be placed in a hole  
(12) in the cover (6).

20 8. A container as claimed in claims 6 or 7,  
c h a r a c t e r i z e d in that the wire conduit  
device also comprises a second member (13, 14, 15, 16)  
for attaching the first member to the cover (6) and/or  
the body (4) during the unwinding.

25 9. A container as claimed in claim 8, c h a r a c -  
t e r i z e d in that said second member comprises a  
circular portion (13, 14, 15) with an outer periphery  
arranged at a distance from the inner walls of said side  
panels (8) of the cover (6) for supporting the first  
member (11), and at least two elements (16) extending  
30 from the outer periphery to said inner walls in the  
transverse direction of said cover (6).

35 10. A container as claimed in claim 9, c h a r a c -  
t e r i z e d in that said circular portion (13, 14, 15)  
of the second member is arranged to abut against the  
inside of the top panel (7) of the cover (6) while its  
elements (16) are arranged to abut both against the inner  
walls of the side panels (8) of the cover (6) and against  
the upper end of the outer walls 5c of the side panels

(5a) of the body (4) for attaching the second member and thus the first member the body (4), during the unwinding.

11. A container according to any one of the preceding claims, c h a r a c t e r i z e d in that two  
5 handles (24) are arranged at the body (4) and in that each handle is made in the form of a strip which is arranged to be fastened along the greater part of one of the side panels (5a) of the body for creating a strong handle.

10 12. A container according to claim 11, c h a r a c - t e r i z e d in that said strip has a portion with a reduced width, that the strip is arranged to be folded in the middle of this portion and in that the folded strip is attached along the inner wall (5b) of said one side  
15 panel (5a) in such a manner that said portion serves as the actual handle.

1/1

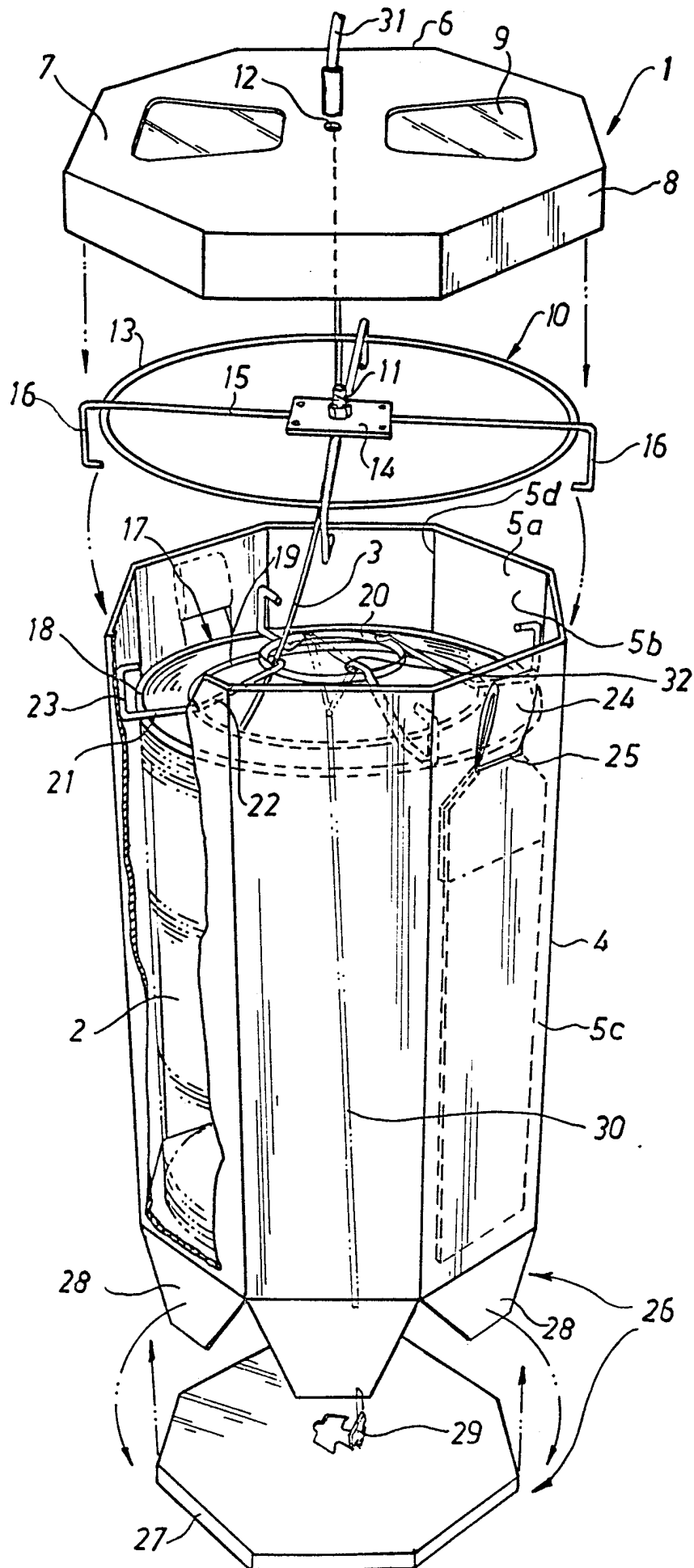

## INTERNATIONAL SEARCH REPORT

International application No.

PCT/SE 97/00816

## A. CLASSIFICATION OF SUBJECT MATTER

IPC6: B65D 85/04, B65H 49/02

According to International Patent Classification (IPC) or to both national classification and IPC

## B. FIELDS SEARCHED

Minimum documentation searched (classification system followed by classification symbols)

IPC6: B65D, B65H

Documentation searched other than minimum documentation to the extent that such documents are included in the fields searched

SE,DK,FI,NO classes as above

Electronic data base consulted during the international search (name of data base and, where practicable, search terms used)

## WPI, CLAIMS

## C. DOCUMENTS CONSIDERED TO BE RELEVANT

Category*	Citation of document, with indication, where appropriate, of the relevant passages	Relevant to claim No.
A	EP 0519424 A1 (THE LINCOLN ELECTRIC COMPANY), 23 December 1992 (23.12.92), figure 2, abstract --	1-12
A	WO 9419258 A1 (SIDERGAS S.R.L.), 1 Sept 1994 (01.09.94), figure 3, abstract --	1-12
A	US 4869367 A (KAWASAKI ET AL), 26 Sept 1989 (26.09.89), figures 6a-d, abstract --	1-12
A	US 5105943 A (LESKO ET AL), 21 April 1992 (21.04.92), figures 1-2, abstract --	1-12

 Further documents are listed in the continuation of Box C.
  See patent family annex.

* Special categories of cited documents:	"T" later document published after the international filing date or priority date and not in conflict with the application but cited to understand the principle or theory underlying the invention
"A" document defining the general state of the art which is not considered to be of particular relevance	"X" document of particular relevance: the claimed invention cannot be considered novel or cannot be considered to involve an inventive step when the document is taken alone
"E" earlier document but published on or after the international filing date	"Y" document of particular relevance: the claimed invention cannot be considered to involve an inventive step when the document is combined with one or more other such documents, such combination being obvious to a person skilled in the art
"L" document which may throw doubts on priority claim(s) or which is cited to establish the publication date of another citation or other special reason (as specified)	"&" document member of the same patent family
"O" document referring to an oral disclosure, use, exhibition or other means	
"P" document published prior to the international filing date but later than the priority date claimed	

Date of the actual completion of the international search

7 January 1998

Date of mailing of the international search report

13.01.98

 Name and mailing address of the ISA/  
 Swedish Patent Office  
 Box 5055, S-102 42 STOCKHOLM  
 Facsimile No. +46 8 666 02 86

Authorized officer

 Kerstin Brinkman  
 Telephone No. +46 8 782 25 00

## INTERNATIONAL SEARCH REPORT

International application No.

PCT/SE 97/00816

C (Continuation). DOCUMENTS CONSIDERED TO BE RELEVANT

Category*	Citation of document, with indication, where appropriate, of the relevant passages	Relevant to claim No.
A	US 2713938 A (R.A. SNYDER), 26 July 1955 (26.07.55), figures 1-2  -----	1-12

# INTERNATIONAL SEARCH REPORT

Information on patent family members

International application No.

02/12/97

PCT/SE 97/00816

Patent document cited in search report	Publication date	Patent family member(s)	Publication date
EP 0519424 A1	23/12/92	SE 0519424 T3 CA 2071419 A,C DE 69204572 D,T ES 2079739 T US 5277314 A	19/12/92 02/05/96 16/01/96 11/01/94
WO 9419258 A1	01/09/94	AT 159911 T EP 0636098 A,B IT 1263490 B IT VR930008 D,V US 5494160 A	15/11/97 01/02/95 05/08/96 23/02/93 27/02/96
US 4869367 A	26/09/89	CA 1169390 A DE 3151803 A,C JP 1437447 C JP 57166269 A JP 62046464 B JP 57168241 A JP 57198741 A	19/06/84 12/08/82 25/04/88 13/10/82 02/10/87 16/10/82 06/12/82
US 5105943 A	21/04/92	NONE	
US 2713938 A	26/07/55	NONE	