

(19) **DANMARK**

(10) **DK/EP 3698015 T3**



(12)

Oversættelse af europæisk patentskrift

Patent- og
Varemærkestyrelsen

-
- (51) Int.Cl.: **E 21 B 37/08 (2006.01)** **E 21 B 21/00 (2006.01)** **E 21 B 33/13 (2006.01)**
E 21 B 37/00 (2006.01) **E 21 B 43/11 (2006.01)**
- (45) Oversættelsen bekendtgjort den: **2024-06-17**
- (80) Dato for Den Europæiske Patentmyndigheds bekendtgørelse om meddelelse af patentet: **2024-05-22**
- (86) Europæisk ansøgning nr.: **18867925.2**
- (86) Europæisk indleveringsdag: **2018-10-17**
- (87) Den europæiske ansøgnings publiceringsdag: **2020-08-26**
- (86) International ansøgning nr.: **NO2018050247**
- (87) Internationalt publikationsnr.: **WO2019078728**
- (30) Prioritet: **2017-10-17 NO 20171650**
- (84) Designerede stater: **AL AT BE BG CH CY CZ DE DK EE ES FI FR GB GR HR HU IE IS IT LI LT LU LV MC MK MT NL NO PL PT RO RS SE SI SK SM TR**
- (73) Patenthaver: **Hydra Systems AS, Postboks 182, 4098 Tananger, Norge**
- (72) Opfinder: **MYHRE, Morten, Notvegen 15, 4056 Tananger, Norge**
LARSEN, Arne Gunnar, Postveien 8, 4319 Sandnes, Norge
ØSTVOLD, Arnold, Gauselbakken 89, 4032 Sandnes, Norge
- (74) Fuldmægtig i Danmark: **Plougmann Vingtoft A/S, Strandvejen 70, 2900 Hellerup, Danmark**
- (54) Benævnelse: **ET SYSTEM OG EN FREMGANGSMÅDE TIL RENGØRING AF ET RINGFORMET OMRÅDE I ET BOREHUL**
- (56) Fremdragne publikationer:
EP-A1- 2 805 010
WO-A1-2012/096580
WO-A1-2013/133719
US-A- 2 512 801
US-A- 3 396 798
US-A- 4 899 821
US-A- 5 372 198
US-A1- 2016 010 423

DESCRIPTION

Description

Technical field

[0001] The invention concerns a system and a method of cleaning an annular area in a subterranean well, for example in a production well or an injection well. Advantageously, the invention may be used in context of plugging such a well, for example for plugging and abandoning (P&A) the well temporarily or permanently.

[0002] More particularly, the present system and method is used in a well section containing a first pipe body surrounded by a second pipe body so as to form a pipe-in-pipe constellation. A first annulus is located between the pipe bodies and contains a substantially clean fluid, whereas a second annulus outwardly surrounds the second pipe body and contains contaminants in a solid, semi-solid or liquid state, or a mixture thereof. Typically, although not necessarily, the second annulus is located between the second pipe body and a surrounding borehole wall formed through subterranean formations (rocks). It is also conceivable for the second annulus to be located between the second pipe body and one or more progressively larger pipe bodies located external to the second pipe body, each of these larger pipe bodies also having an annulus external thereto that is likely to contain such contaminants. In context of the present invention, the noted contaminants may comprise various particles, debris, deposits and/or well fluids, for example filter cake, formation particles, drill cuttings, drilling additives, e.g. barite, cement particles and/or residues and old drilling fluids (or similar), that have settled out or remain in the second annulus from previous well operations.

[0003] The above-described pipe-in pipe constellation and annular content situation may exist in a production well containing an inner production tubing surrounded by a production casing or liner, or in an injection well containing an inner injection tubing surrounded by an injection casing or liner. The inner tubing generally extends between the surface and a permeable zone of the well and is used to convey fluids out of the well (production) or into the well (injection). These and other aspects of such pipe-in-pipe constellations and annular content situations would be familiar to the skilled well practitioner.

Background

[0004] Owing to e.g. significant time and cost savings over conventional section milling techniques, the so-called Perf-Wash-Cement method ("PWC[®]" and "PWC, Perf-Wash-

Cement[®]) has, since about year 2010, gained increasing interest and use in the oil and gas industry as a very efficient and environmentally safe method of plugging wells. Contrary to the section milling techniques, the PWC[®] method does not require one or more pipe bodies (e.g. casings, liners) to be milled away and removed before placing a plugging material (e.g. cement) in an entire cross section (rock-to-rock) of a well. One or more pipe bodies (casings/liners) located within a well section are instead perforated to gain access to one or more outwardly surrounding annuli. These perforations or holes are generally formed simultaneously, or substantially simultaneously, through the wall(s) of the one or more pipe bodies. A perforating gun is typically used to do so, although other suitable perforating devices also may be used for this purpose. Various contaminants, such as those described above, are typically present in such annuli and must be removed before placing the plugging material in the well section. A washing or jetting tool is therefore inserted into the (innermost) pipe body to wash away and remove contaminants present along the perforated section of the well. A washing fluid is discharged from the washing or jetting tool and flows through perforations previously formed in the one or more pipe bodies, thereby cleaning away contaminants present in the one or more surrounding annuli. The washing or jetting tool is typically moved down and then up along the perforated section during a washing operation, although washing only in one direction may prove sufficient. A suitable fluidized plugging material is then introduced in the (innermost) pipe body and is placed along the perforated and cleaned section, thereby forming a cross-sectional (rock-to-rock) barrier in the well. Cement slurry is typically used for this purpose, although other types of plugging materials may also be used.

Prior art

[0005] When employing the PWC[®] method, the following prior art references disclose different types of washing/jetting tools suitable for cleaning away contaminants in the one or more annuli surrounding the one or more pipe bodies.

[0006] WO 2012/096580 A1 discloses the PWC[®] method in general and more specific terms. This publication describes embodiments of a washing tool generally referred to as the HydraWash[™] washing tool in the oil and gas industry. This washing tool may comprise spaced apart and radially extending flow guides which, in operation, cooperate with an inside of a casing to form a confined pressure compartment enclosing a limited number of holes in the casing. In operation, a washing fluid is supplied to the confined pressure compartment via a suitable work string extending to surface, for example a jointed pipe string (e.g. a drill string) or a coiled tubing string. The washing fluid, which is located within the compartment, is then directed outward through the limited number of holes in the casing so as to clean away contaminants in an annulus surrounding the casing. In WO 2012/096580 A1, the HydraWash[™] washing tool is generally disclosed for use in a single casing, and for washing and cleaning in a single annulus external thereto. There is no disclosure in WO 2012/096580 A1 about washing through multiple sets of holes formed through multiple casings (i.e. a casing-in casing

constellation) and simultaneously washing away contaminants in surrounding multiple annuli.

[0007] WO 2013/133719 A1 discloses a more specific variant of the PWC[®] method. In this publication, the PWC[®] method is used to form a cross-sectional plug in a well section containing at least two substantially concentric pipe bodies (e.g. casing strings) having at least two corresponding annuli external thereto (i.e. a pipe-in-pipe constellation). The washing operation is carried out using a washing tool generally referred to as the HydraHemera[™] jetting tool in the oil and gas industry. The jetting tool is typically connected to a work string extending to surface, for example a jointed pipe string or a coiled tubing string. The jetting tool also features a plurality of outlets, e.g. nozzles, angled at different angles. In operation in a well, a flushing fluid discharges at high velocity from the differently angled outlets so as to produce flushing jets directed in different directions relative to a longitudinal axis of the pipe bodies. The angled flushing jets therefore penetrate holes formed in the pipe bodies and enter the surrounding annuli from different directions. By so doing, the flushing jets gain better access to the annuli and contaminants therein so as to effectively dislodge and remove the contaminants within the annuli. To facilitate the access to these annuli, the noted holes are typically of a relatively large size. As such, the holes used with the HydraHemera[™] jetting tool may have a diameter in the order of 20-35 millimetres, which is substantially larger than the hole diameters, typically in the order of 8-15 millimetres, commonly used with the HydraWash[™] washing tool in a single casing setting. There is no disclosure in WO 2013/133719 A1 about an inner annulus containing a substantially clean fluid and (only) an outer annulus containing contaminants to be removed therefrom, which is quite contrary to the starting point of the present invention.

[0008] WO 2016/200269 A1 discloses yet another variant of the PWC[®] method used for plugging and abandoning a well. In this publication, the noted HydraHemera[™] jetting tool is typically used in a well setting with a single pipe string having only one surrounding annulus, which contains contaminants to be removed therefrom. This is also a different starting point than that of the present invention.

Summary

[0009] The primary object of the present invention is to provide a cleaning technology for removing contaminants in an annulus outwardly surrounding two pipe bodies arranged in a pipe-in-pipe fashion and having an intermediate annulus containing a substantially clean fluid, which is defined herein as a fluid being substantially devoid of flow-inhibiting contaminants, as explained in further detail below.

[0010] A further object of the present invention is to provide a useful alternative to the above-described prior art variants of the PWC[®] method.

[0011] The objects are achieved by virtue of features and steps disclosed in the following description and in the subsequent claims.

[0012] In a first aspect, the present invention comprises a system for cleaning an annular area in a well, characterized in that the system comprises:

- a first pipe body and a surrounding second pipe body positioned in the well;
- a first annulus located between the first and second pipe bodies, the first annulus containing a clean fluid defined as a fluid being substantially devoid of flow-inhibiting contaminants;
- a second annulus outwardly surrounding the second pipe body, the second annulus containing contaminants to be removed therefrom;
- a plurality of sets of holes formed through walls of the first and second pipe bodies and dispersed along a longitudinal section of the well for allowing fluid communication between the first pipe body and the second annulus, each set of holes comprising holes aligned substantially radially through the first and second pipe bodies; and
- a washing tool positioned in the first pipe body at the longitudinal section, the washing tool comprising a set of spaced apart flow guides configured to enclose of a limited number of sets of holes along the longitudinal section, the flow guides cooperating with an inside of the first pipe body to form a confined pressure compartment for the limited number of sets of holes when operational in the well.

[0013] Considering the above discussion regarding the PWC[®] method and the associated prior art publications, it is evident that the present invention (system and method) employs a washing tool resembling the HydraWash[™] washing tool disclosed in e.g. WO 2012/096580 A1. The present pipe constellation, however, resembles the multiple casing (and annuli) setting disclosed in e.g. WO 2013/133719 A1, where the HydraHemera[™] jetting tool is used for simultaneous cleaning in multiple annuli. As will become clear hereafter, the present invention employs a HydraWash[™] type of washing tool in a HydraHemera[™] type of well setting, i.e. in a setting with multiple pipes and multiple annuli (pipe-in-pipe constellation). The present invention, however, exhibits distinct differences relative to the technologies disclosed in the noted prior art publications.

[0014] In order to avoid confusion, a set of holes is defined herein as a first hole formed through the tubular wall of the first pipe body, wherein the first hole is aligned substantially in a radial direction with a second hole formed through the tubular wall of the second pipe body, which surrounds the first pipe body.

[0015] Preferably, the plurality of sets of holes are dispersed in a substantially regular fashion along the longitudinal section, for example having a substantially even distance between (spacing) and number per unit length (density) of sets of holes along and around all or part of the longitudinal section. Such a distribution of sets of holes allows for proper access to the

second annulus, and cleaning thereof, during a washing operation. Advantageously, the sets of holes may be formed simultaneously, or substantially simultaneously, through the wall(s) of the pipe bodies.

[0016] Further, as noted, the clean fluid present in the first annulus between the first and second pipe bodies is defined as a fluid being substantially devoid of contaminants of the above-mentioned types. As such, the clean fluid could comprise a common completion fluid, typically a type of brine, or seawater, diesel or similar. Such clean fluids, e.g. completion fluids, would be familiar to the skilled well practitioner.

[0017] Yet further, the first pipe body would typically comprise a production tubing or an injection tubing, whereas the second pipe body would typically comprise a production casing or liner, or an injection casing or liner. The present invention, however, would also be applicable with other types of pipe bodies, e.g. various casing/liner sizes, and other types of pipe-in-pipe constellations, e.g. casing-in-casing or liner-in casing constellations.

[0018] When operating the present system, a pressurized washing fluid is supplied to the confined pressure compartment. The pressurized washing fluid then discharges from the confined pressure compartment as high velocity flushing jets passing through respective radially aligned holes of the limited sets of holes, which are located within the confined compartment. The flushing jets also pass through the clean fluid present in the first annulus. Owing to lack of flow-inhibiting contaminants in the clean fluid, a significant amount of kinetic energy is preserved in the flushing jets when entering the second annulus, which allows the flushing jets to engage and clean away contaminants located in the second annulus. The contaminants may be removed via other holes located along the longitudinal section, and via the first pipe string and/or the first annulus. It is therefore conceivable that the contaminants may be conducted to the surface of the well for removal. Alternatively, the contaminants may be deposited deeper in the well or may even be injected (i.e. "bullheaded") into a deeper formation in the well.

[0019] Advantageously, the washing tool may be connected to a lower end of a suitable tubular work string for operation of the washing tool. The work string may, for example, be a jointed pipe string (e.g. a drill string) or a coiled tubing string extending to the surface of the well for supplying a pressurized washing fluid to the confined pressure compartment during operation of the present system.

[0020] It is also conceivable for a suitable downhole pump to be connected to the confined pressure compartment for supplying pressurized washing fluid thereto.

[0021] Moreover, at least a majority of the sets of holes may have a hole diameter in the order of 2-15 millimetres. More particularly, the hole diameter may be in the order of 2,5-10 millimetres. Still more particularly, the hole diameter may be in the order of 2,5-7 millimetres.

[0022] Further, the density of sets of holes along and around all or part of the longitudinal

section may be in the order of 30-80 sets of holes per meter, more particularly in the order of 50-70 sets of holes per meter, for example 60 sets of holes per meter.

[0023] Yet further, the flow guide spacing (distance between the flow guides) may be in the order of 10-45 centimetres (4-18 inches), more particularly in the order of 15-35 centimetres (6-14 inches), for example 30 centimetres (12 inches).

[0024] A perforating gun, which is furnished with shaped explosive charges capable of generating narrow and long perforations, so-called production perforations, through the first and second pipe bodies, is considered to be appropriate for making such hole sizes in the pipe bodies.

[0025] The hole diameters employed herein would generally be smaller than the hole diameters typically used with the noted HydraWash™ washing tool. Advantageously, the generally smaller hole sizes used in the present sets of holes allow the smaller holes to function as nozzle-resembling outlets similar to those embodied in the noted HydraHemera™ jetting tool. The present sets of holes, however, are not angled as in the jetting tool and instead extend in a substantially radial direction relative to a longitudinal axis of the pipe bodies. In operation, when the washing fluid in the confined compartment is pressurized sufficiently, the limited number of holes within the confined compartment therefore discharge high velocity fluid jets capable of penetrating through the substantially radially aligned holes of both pipe bodies and into the second annulus to facilitate cleaning therein.

[0026] It is also conceivable that, for a given set of holes, the first hole in the first pipe body has a different diameter than the diameter of the second hole in the second pipe body. As such, the first hole may have a smaller diameter than the diameter of the second hole, which would provide easier access for the fluid jets into the second annulus.

[0027] Given a certain fluid pressure, flow guide spacing and number of holes within the confined pressure compartment, it is clear that the diameter of the first hole (in the first pipe body) will affect the flow rate and the discharge velocity (and kinetic energy) of the flushing jets discharging from the pressure compartment of the washing tool. The discharge velocity will increase with decreasing hole diameter. It is also clear that a number of parameters will affect the function and effect of the washing tool, such as type of washing fluid used and its fluid density and viscosity; size, density and distribution of holes along the longitudinal section of the well; flow guide spacing; fluids present in the well; restrictions in fluid pressures and flow rates due to operational constraints of associated equipment, e.g. pressure limitations for coiled tubing and pump rate limitations for pumps. It is therefore difficult to provide specific parameters or parameter combinations suitable when practising the present invention (system and method) in a well. It is however believed that a skilled well practitioner, once familiar with the teachings of the present invention, would readily select suitable combinations of such parameter to optimize the function and effect of the invention in a specific well setting.

[0028] In one embodiment of the system, one or more sets of holes at a bottom part of the

longitudinal section have a hole diameter being larger than the hole diameter of said majority of sets of holes. Larger holes at the bottom part of the longitudinal section may prove advantageous for facilitating subsequent displacement of a fluidized plugging material into the first and second annuli, as specified below in an embodiment of the present method.

[0029] Additionally or alternatively, one or more sets of holes at an upper part of the longitudinal section may have a hole diameter being larger than the diameter of said majority of sets of holes. Larger holes at the upper part of the longitudinal section may prove advantageous for facilitating removal of contaminants dislodged and washed away from the second annulus at the beginning of the washing operation. This is particularly useful when the washing operation (typically) is initiated in a top-down fashion along the longitudinal section.

[0030] Yet further, the flow guides may comprise radially extending collars.

[0031] In one embodiment, one or more of the radially extending collars are structured for sealing, at least partially, against the surrounding first pipe body. Such radially extending collars may comprise cup-shaped elements, typically termed "swab cups" in the industry. Such cups may be formed of rubber or elastomer materials.

[0032] In another embodiment, the radially extending collars comprise one or more radially expandable sealing devices structured for selective activation and expansion towards the first pipe body. As such, the one or more of the radially expandable sealing devices may comprise an inflatable element, for example an inflatable packer. These radially expandable sealing devices may also be structured for selective deactivation and retraction from the first pipe body, which may allow the sealing devices to be set and unset multiple times within the first pipe body, thereby also allowing the sealing devices to be moved with relative ease when in a retracted position.

[0033] Moreover, one or more flow guides may be structured for partial bypassing of fluid in a longitudinal direction within the first pipe body. In operation in the well, a partial flow of the washing fluid may therefore pass the flow guide(s), however without imparting a significant pressure drop in the confined pressure compartment, which otherwise might negatively affect the washing function of the washing tool. The noted flow guides may therefore include, or be furnished with, one or more bypass conduits. Additionally or alternatively, one or more peripheral sectors of the flow guides may have a smaller diameter than the inner diameter of the first pipe body, thereby providing bypass channels between the flow guide(s) and the first pipe body. Such bypassing of washing fluid during operation will create a limited longitudinal flow of fluid inside the first pipe, which may prove advantageous for facilitating removal of contaminants via the first pipe.

[0034] In one embodiment, therefore, one or more flow guides above the confined pressure compartment are structured for partial bypassing of fluid in an upward direction within the first pipe body. During operation, this will create a limited upwardly directed flow of fluid inside the first pipe body for facilitating removal of contaminants to the surface of the well.

[0035] In a second aspect, the present invention comprises a method of cleaning an annular area in a well, characterized in that the well comprises:

a first pipe body and a surrounding second pipe body;

a first annulus located between the first and second pipe bodies, the first annulus containing a clean fluid defined as a fluid being substantially devoid of flow-inhibiting contaminants; and

a second annulus outwardly surrounding the second pipe body, the second annulus containing contaminants to be removed therefrom;

the method comprising the steps of:

1. (A) forming and dispersing, along a longitudinal section of the well, a plurality of sets of holes through walls of the first and second pipe bodies for allowing fluid communication between the first pipe body and the second annulus, each set of holes comprising holes aligned substantially radially through the first and second pipe bodies;
2. (B) positioning a washing tool in the first pipe body at the longitudinal section, the washing tool comprising a set of spaced apart flow guides configured to enclose a limited number of sets of holes along the longitudinal section, the flow guides cooperating with an inside of the first pipe body to form a confined pressure compartment for the limited number of sets of holes;
3. (C) supplying a pressurized washing fluid to the confined pressure compartment and discharging the washing fluid therefrom as high velocity flushing jets passing through respective aligned holes of the limited sets of holes located within the confined pressure compartment, the flushing jets also passing through the clean fluid in the first annulus, thereby allowing the flushing jets to engage and clean away contaminants located in the second annulus; and
4. (D) moving the washing tool along the longitudinal section whilst supplying pressurized washing fluid to the confined pressure compartment, thereby cleaning away and thus removing contaminants from the second annulus along the longitudinal section.

[0036] It is clear, from this definition of the method, that the present system (described above) is inherent to the present method. For this reason, all of the above features and comments relating to the present system are also applicable to the present method. The comments relating to the preceding discussion on the PWC[®] method are also generally applicable to the present method and system.

[0037] Advantageously, in one embodiment, the method comprises connecting the washing tool to a lower end of a suitable tubular work string, for example a jointed pipe string (e.g. a drill string) or a coiled tubing string, for operation of the washing tool.

[0038] Further, the method may comprise discharging the washing fluid from the holes in the

first pipe body at a discharge velocity of at least 15 metres per second. More particularly, the method may comprise discharging the washing fluid at a discharge velocity of at least 50 metres per second. Discharge velocities in the order of 75-200 metres per second may also prove appropriate in some well scenarios.

[0039] The washing fluid used in the method may comprise drilling mud or some other suitable fluid, e.g. water or even diesel.

[0040] Yet further, the method may comprise a subsequent step (E) of displacing, e.g. pumping, a fluidized plugging material into the first pipe body and placing the plugging material along at least the longitudinal section of the well, also allowing the fluidized plugging material to displace into the first annulus and the cleaned second annulus via the sets of holes in the first and second pipe bodies, thereby forming a cross-sectional (rock-to-rock) plug in the well. When including such a step (E), the method would therefore represent a variant of the noted Perf-Wash-Cement method ("PWC[®]" and "PWC, Perf-Wash-Cement[®]").

[0041] The fluidized plugging material may comprise any suitable material or combinations of such materials. Therefore, the fluidized plugging material may comprise at least one material chosen from a group comprising cementitious materials, particulate masses, polymer or epoxy materials (resins).

[0042] In one embodiment, the method comprises displacing, e.g. pumping, the fluidized plugging material via the washing tool. This may offer more controlled displacement of the plugging material into the surrounding annuli.

[0043] In another embodiment, the method comprises pumping the fluidized plugging material out of a lower end of a suitable tubular work string, typically a jointed pipe string (e.g. a drill string) or a coiled tubing string. As such, the noted work string, which may be used with the washing tool, may also be employed for pumping the fluidized plugging material.

[0044] Additionally or alternatively, the method may comprise forming, between steps (D) and (E), one or more second sets of holes within the longitudinal section and through walls of the first and second pipe bodies, the second sets of holes having a larger hole diameter than the hole diameter of the sets of holes formed in step (A). The larger hole diameter of the second sets of holes allow better fluid communication for displacing the fluidized plugging material into the first and second annuli.

[0045] Moreover, the method may comprise using, in step (A), a perforating gun to form said sets of holes in the first and second pipe bodies. As such, the perforating gun may include explosive charges for generating narrow and long perforations, so-called production perforations, through the first and second pipe bodies.

[0046] Alternatively, the method may comprise using, in step (A), a mechanical cutting device to form said sets of holes in the first and second pipe bodies. Such a cutting device may be

structured for cutting, drilling or punching holes through the pipe bodies.

[0047] Yet alternatively, the method may comprise using, in step (A), an abrasive jetting device to form said sets of holes in the first and second pipe bodies. Such a jetting device may be structured for discharging one or more abrasive cutting jets at a high velocity for cutting holes through the pipe bodies. The jets are formed from a suitable fluid containing abrasive materials, for example fine grained sand materials.

[0048] Furthermore, the method may comprise forming, in step (A), one or more sets of holes at a bottom part of the longitudinal section, the one or more bottom sets of holes having a larger hole diameter than the hole diameter of a majority of the sets of holes. As noted above, this may prove advantageous for facilitating displacement of the fluidized plugging material into the first and second annuli along the longitudinal section.

[0049] Additionally or alternatively, the method may comprise forming, in step (A), one or more sets of holes at an upper part of the longitudinal section, the one or more upper sets of holes having a larger hole diameter than the hole diameter of a majority of the sets of holes. As noted above, this may prove advantageous for facilitating removal of contaminants dislodged and washed away from the second annulus at the beginning of the washing operation.

Brief description of the drawings

[0050] An exemplary embodiment of the invention is described and depicted in the accompanying drawings, where:

Figure 1

shows, in side view, a well to be plugged and abandoned using a system and a method according to the present invention;

Figure 2

shows, in side view, the well after having lowered a perforating gun into the well, and after having made holes through two pipe bodies along a section of the well;

Figure 3

shows, in side view, the well after having lowered a washing tool into the well, and whilst operating the washing tool at a top part of the well section;

Figure 4

shows, in side view, the washing tool whilst washing at a lower part of the well section, and after having moved the washing tool in a top-down fashion within the well section; and

Figure 5

shows, in side view, the well after having pumped a fluidized plugging material into the well section, and after having formed a cross-sectional plug along the well section.

[0051] The figures are schematic and merely show steps, details and equipment being essential to the understanding of the invention. Further, the figures are distorted with respect to relative dimensions of elements and details shown in the figures. The figures are also somewhat simplified with respect to the shape and richness of detail of such elements and details. Elements not being central to the invention may also have been omitted from the figures. Further, equal, equivalent or corresponding details shown in the figures will be given substantially the same reference numerals.

Detailed description of an embodiment of the invention

[0052] Figure 1 shows a well 2 to be plugged and abandoned using a system and a method according to the present invention. The well 2 comprises a first pipe body 4 and a surrounding second pipe body 6. A first annulus 8 is located between the first and second pipe bodies 4, 6 and contains a clean fluid 10, here in the form of a substantially solids-free completion fluid. A second annulus 12 outwardly surrounds the second pipe body 6 and contains contaminants 14 to be removed therefrom in a subsequent washing operation. In this embodiment, the second annulus 12 is located between the second pipe body 6 and a surrounding borehole wall 16 formed through subterranean formations 18. In practice, the first pipe body 4 could be a production tubing or an injection tubing extending between the surface of the well 2 and a deeper formation (not shown). The second pipe body 6, however, could be a production casing or an injection casing extending between the surface and a shallower level in the well 2 so as to surround a shallower section of said production or injection tubing, as shown in the figures. A sealing material, e.g. cement or similar, could also be present in the second annulus 12 at a bottom section (shoe) of the first pipe body 4 (not shown). At this stage, before using the present invention, the first pipe body 4 may contain produced or injected fluids.

[0053] Figure 2 shows the well 2 after having lowered a perforating gun 20 down to a section of the well 2. The gun 20 may be tubing-conveyed or wireline-conveyed, as would be familiar to the skilled well practitioner. In this embodiment, the perforating gun 20 is shown connected to a lower end of a tubular work string 36, here in the form of a coiled tubing string. Upon activating explosive charges along the perforating gun 20, a plurality of sets of holes 22 are formed and dispersed along a longitudinal section L of the well 2. The extent of the hole sets 22 formed along the first pipe body 4 define the longitudinal section L. In this embodiment, these particular charges generate holes having a diameter of ca. 5 millimetres. The sets of holes 22 are formed through walls of the first and second pipe bodies 4,6 for allowing fluid communication between the first pipe body 4 and the second annulus 12. Each set of holes 20 comprises a first hole 22a formed through the first pipe body 4, and a second hole 22b formed through the second pipe body 6. The first and second holes 22a, 22b are aligned in a substantially radial direction relative to a longitudinal axis of the first and second pipe bodies 4, 6. In this embodiment, the sets of holes 22 are dispersed in a substantially regular and even fashion along the longitudinal section L, having a substantially even hole set spacing and density along the longitudinal section L.

[0054] Figure 3 shows the well 2 after having set a mechanical plug 24 inside the first pipe body 4, and below the longitudinal section L, and after having lowered a washing tool 26 into the first pipe body 4 and having positioned it at a top part of the longitudinal section L. The washing tool 26 comprises a set of spaced apart flow guides 28a, 28b configured to enclose of a limited number of sets of holes 22 along the longitudinal section L. In this embodiment, the spaced apart flow guides 28a, 28b comprise radially extending collars in the form of so-called swab cups sealing, at least partially, against an inside of first pipe body 4. The flow guides 28a, 28b cooperate with the inside of the first pipe body 4 to form a confined pressure compartment 30 for enclosing said limited number of sets of holes 22 when operational in the well 2. The washing tool 26 also includes a central mandrel 32 furnished with discharge openings 34 for allowing fluid communication between the pressure compartment 30 and an upper end of the mandrel 32. Said tubular work string 36 (coiled tubing string) is shown connected to the upper end of the mandrel 32 for operation of the washing tool 26.

[0055] Figure 3 also shows the washing tool 26 whilst being supplied a pressurized washing fluid 38, here in the form of drilling mud, from the surface via the work string 36 and into the confined compartment 30 via the mandrel 32 and the discharge openings 34 therein. The pressurized washing fluid 38 discharges from the compartment 30 as high velocity flushing jets 40 passing through respective aligned holes 22a, 22b of the limited sets of holes 22 located within the confined compartment 30. By so doing, the flushing jets 40 also pass through the clean fluid 10 in the first annulus 8, thereby allowing the flushing jets 40 to engage and clean away contaminants 14 located within a top part of the second annulus 12. In Figures 3 and 4, the flushing jets 40 are shown as straight arrows through the aligned holes 22a, 22b. In this embodiment, the liberated contaminants 14 entrained with the washing fluid 38 are removed via other hole sets 22, and via the second annulus 12, at this top part of the longitudinal section L. The returning washing fluid 38 with liberated contaminants 14 then enter the first pipe body 4 above the location of the washing tool 26 and flows to the surface of the well 2. The flow path of the returning washing fluid 38 is indicated with curved arrows in Figures 3 and 4.

[0056] Figure 4 shows the washing tool 26 whilst washing at a bottom part of the longitudinal section L, and after having moved the washing tool 26 successively downward inside the first pipe body 4. At this stage of the washing operation, the flushing jets 40 have dislodged and cleaned away contaminants 14 within substantially the entire second annulus 12 along the perforated longitudinal section L. Once the downward pass has been completed, the washing tool 26 is typically moved upward along the longitudinal section L to facilitate further (residual) cleaning within the second annulus 12. The down-and-up washing procedure may be repeated one or more times, if desired or required.

[0057] Figure 5 shows the well 2 after having completed a subsequent step of pumping a fluidized plugging material 42 into the first pipe body 4 and placing the plugging material 42 along at least the longitudinal section L of the well 2. By so doing, the fluidized plugging material 42 is also allowed to displace into the first annulus 8 and the cleaned second annulus 12 via the sets of holes 22 in the first and second pipe bodies 4, 6, thereby forming a cross-

sectional plug in the well 2. The plugging material 42 may be displaced into the well 2 in any suitable manner, as would be known to the skilled well practitioner.

REFERENCES CITED IN THE DESCRIPTION

Cited references

This list of references cited by the applicant is for the reader's convenience only. It does not form part of the European patent document. Even though great care has been taken in compiling the references, errors or omissions cannot be excluded and the EPO disclaims all liability in this regard.

Patent documents cited in the description

- [WO2012096580A1 \[0006\] \[0006\] \[0006\] \[0013\]](#)
- [WO2013133719A1 \[0007\] \[0007\] \[0013\]](#)
- [WO2016200269A1 \[0008\]](#)

Patentkrav

1. System til rengøring af et ringformet område i et borehul (2),

kendetegnet ved, at systemet omfatter:

- 5 - et første rørlegeme (4) og et omgivende andet rørlegeme (6) positioneret i borehullet (2);
- en første ring (8) placeret mellem det første og det andet rørlegeme (4, 6), hvor den første ring (8) indeholder et rent fluid (10), der er defineret som et fluid, der i alt væsentligt er fri for flowhæmmende kontaminanter;
- 10 - en anden ring (12), der udadtil omgiver det andet rørlegeme (6), hvor den anden ring (12) indeholder kontaminanter (14), der skal fjernes derfra;
- en flerhed af sæt af huller (22) dannet gennem vægge af det første og andet rørlegeme (4, 6) og spredt langs en langsgående sektion (L) af
- 15 borehullet (2) for at tillade fluidforbindelse mellem det første rørlegeme (4) og den anden ring (12), hvor hvert sæt af huller (22) omfatter huller (22a, 22b), der er anbragt på linje i alt væsentligt radialt gennem det første og det andet rørlegeme (4, 6); og
- et vaskeværktøj (26) positioneret i det første rørlegeme (4) ved den
- 20 langsgående sektion (L), idet vaskeværktøjet (26) omfatter et sæt med indbyrdes afstand anbragte flowføringer (28a, 28b) konfigureret til at omslutte et begrænset antal sæt af huller (22) langs den langsgående sektion (L), idet flowføringerne (28a, 28b) samvirker med en inderside af det første rørlegeme (4) for at danne et lukket trykkammer (30) til det
- 25 begrænsede antal sæt af huller (22), når de er i drift i borehullet (2).

2. Systemet ifølge krav 1, hvor vaskeværktøjet (26) er forbundet med en nedre ende af en rørformet arbejdsstreng (36) til drift af vaskeværktøjet (26).

30 **3.** Systemet ifølge krav 1 eller 2, hvor i det mindste størstedelen af sættene af huller (22) har en hul diameter i størrelsesordenen 2-15 millimeter.

4. Systemet ifølge krav 3, hvor et eller flere sæt af huller (22) ved en bunddel af den langsgående sektion (L) har en hul diameter, der er større end hul diameteren

af størstedelen af sæt af huller (22).

5. Systemet ifølge krav 3 eller 4, hvor et eller flere sæt af huller (22) ved en øvre del af den langsgående sektion (L) har en hul diameter, der er større end
5 diameteren af størstedelen af sæt af huller (22).

6. Systemet ifølge et hvilket som helst af kravene 1-5, hvor flowføringerne (28a, 28b) omfatter radialt forløbende kraver.

10 **7.** Systemet ifølge krav 6, hvor en eller flere af de radialt forløbende kraver (28a, 28b) er struktureret til tætning, i det mindste delvist, mod det omgivende første rørlegeme (4).

8. Systemet ifølge krav 6, hvor de radialt forløbende kraver (28a, 28b) omfatter
15 en eller flere radialt ekspanderbare tætningsindretninger, der er struktureret til selektiv aktivering og ekspansion mod det første rørlegeme (4).

9. Systemet ifølge et hvilket som helst af kravene 1-8, hvor en eller flere flowføringer (28a, 28b) er struktureret til delvis omlodning af fluid i en
20 langsgående retning inden i det første rørlegeme (4).

10. Fremgangsmåde til rengøring af et ringformet område i et borehul (2),
kendetegnet ved, at borehullet (2) omfatter:

et første rørlegeme (4) og et omgivende andet rørlegeme (6);
25 en første ring (8) placeret mellem det første og det andet rørlegeme (4, 6), idet den første ring (8) indeholder et rent fluid (10), der er defineret som et fluid, der i alt væsentligt er fri for flowhæmmende kontaminanter; og en anden ring (12), der udadtil omgiver det andet rørlegeme (6), idet den anden ring (12) indeholder kontaminanter (14), der skal fjernes derfra;

30 hvilken fremgangsmåde omfatter trinnene:

(A) dannelse og spredning langs en langsgående sektion (L) af borehullet (2) af en flerhed af sæt af huller (22) gennem væggene af det første og andet rørlegeme (4, 6) for at tillade fluidforbindelse mellem det første rørlegeme (4) og den anden ring (12), idet hvert sæt af huller (22)

- omfatter huller (22a, 22b), der er anbragt på linje i alt væsentligt radially gennem det første og andet rørlegeme (4, 6);
- (B) positionering af et vaskeværktøj (26) i det første rørlegeme (4) ved den langsgående sektion (L), idet vaskeværktøjet (26) omfatter et sæt med
- 5 indbyrdes afstand anbragte flowføringer (28a, 28b) konfigureret til at omslutte en begrænset antal sæt af huller (22) langs den langsgående sektion (L), idet flowføringerne (28a, 28b) samvirker med en inderside af det første rørlegeme (4) for at danne et lukket trykkammer (30) til det begrænsede antal sæt af huller (22);
- 10 (C) tilførsel af et tryksat vaskefluid (38) til det lukkede trykkammer (30) og udledning af vaskefluidet (38) derfra som højhastighedsskyllestråler (40), der passerer gennem respektive huller (22a, 22b) anbragt på linje i de begrænsede sæt af huller (22) placeret i det lukkede trykkammer (30), idet skyllestrålerne (40) også passerer gennem det rene fluid (10) i den første
- 15 ring (8), hvorved skyllestrålerne (40) kan gå i indgreb og fjerne kontaminanter (14) placeret i den anden ring (12); og
- (D) bevægelse af vaskeværktøjet (26) langs den langsgående sektion (L), mens der tilføres tryksat vaskefluid (38) til det lukkede trykkammer (30), hvorved der rengøres og dermed fjernes kontaminanter (14) fra den anden
- 20 ring (12) langs den langsgående sektion (L).

- 11.** Fremgangsmåden ifølge krav 10, omfattende forbindelse af vaskeværktøjet (26) til en nedre ende af en rørformet arbejdsstreng (36) til drift af vaskeværktøjet (26).
- 25
- 12.** Fremgangsmåden ifølge krav 10 eller 11, omfattende udledning af vaskefluidet (38) fra hullerne (22a) i det første rørlegeme (4) med en udledningshastighed på mindst 15 meter pr. sekund.
- 30 **13.** Fremgangsmåden ifølge krav 12, omfattende udledning af vaskefluidet (38) med en udledningshastighed på mindst 50 meter pr. sekund.
- 14.** Fremgangsmåden ifølge et hvilket som helst af kravene 10-13, omfattende et efterfølgende trin (E) med forskydning af et fluidiseret tilstopningsmateriale (42)
- 35 ind i det første rørlegeme (4) og placering af tilstopningsmaterialet (42) langs i

4

det mindste den langsgående sektion (L) af borehullet (2), hvilket også tillader, at det fluidiserede tilstopningsmateriale (42) forskydes ind i den første ring (8) og den rensede anden ring (12) via sættene af huller (22) i det første og andet rørlegeme (4, 6), hvorved der dannes en tværgående prop i borehullet (2).

5

15. Fremgangsmåden ifølge krav 14, omfattende forskydning af det fluidiserede tilstopningsmateriale (42) via vaskeværktøjet (26).

DRAWINGS

Drawing

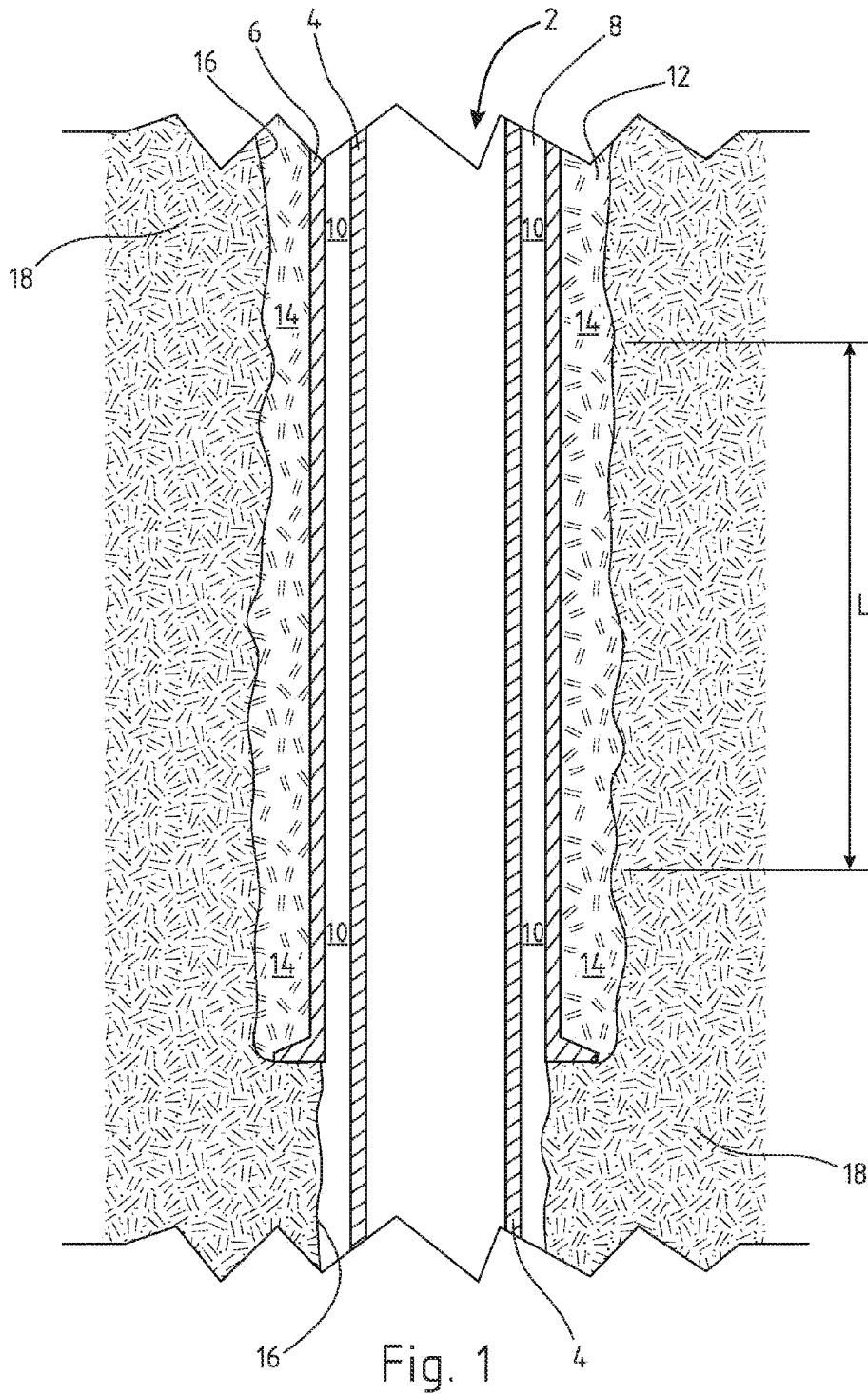

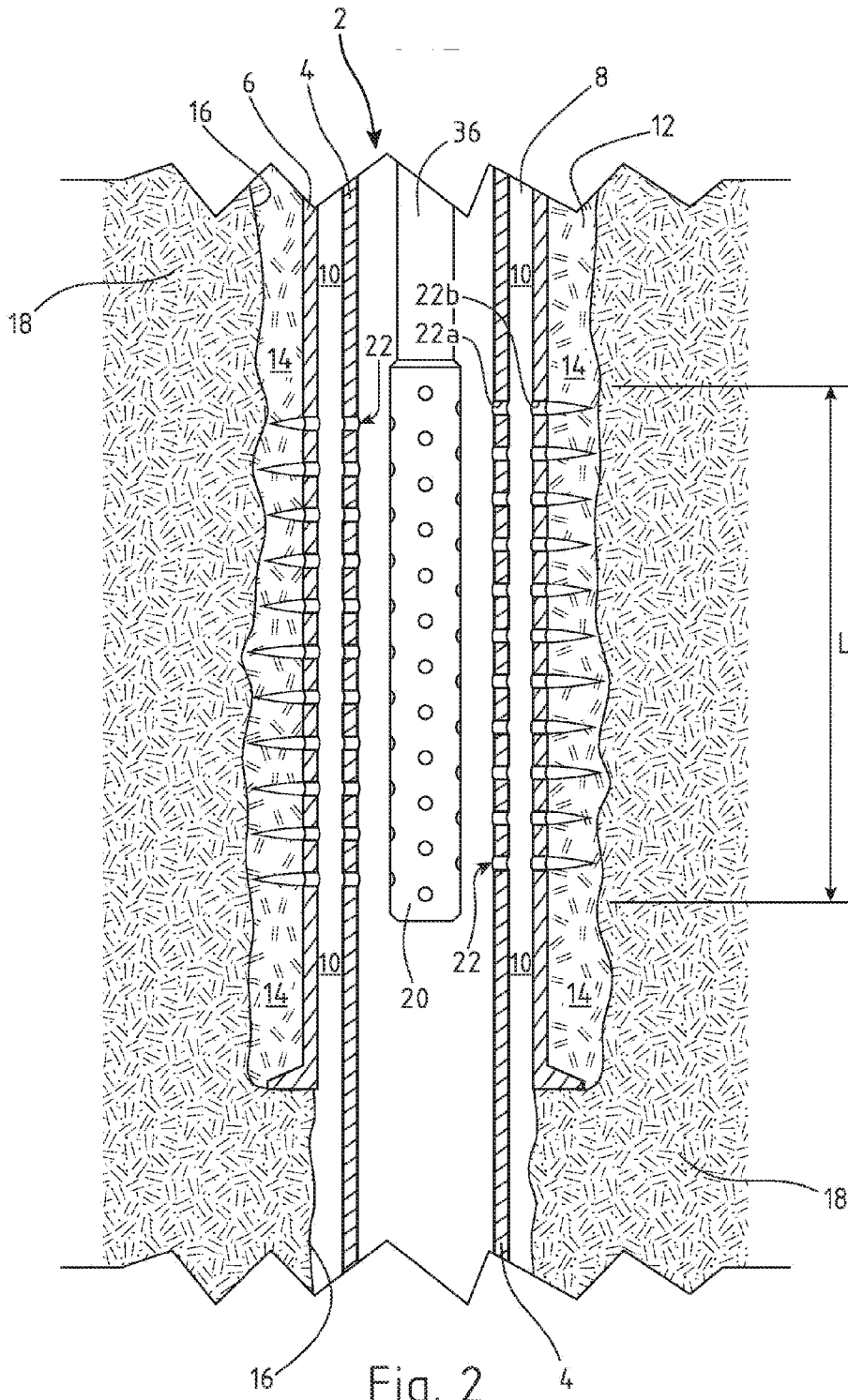

Fig. 2

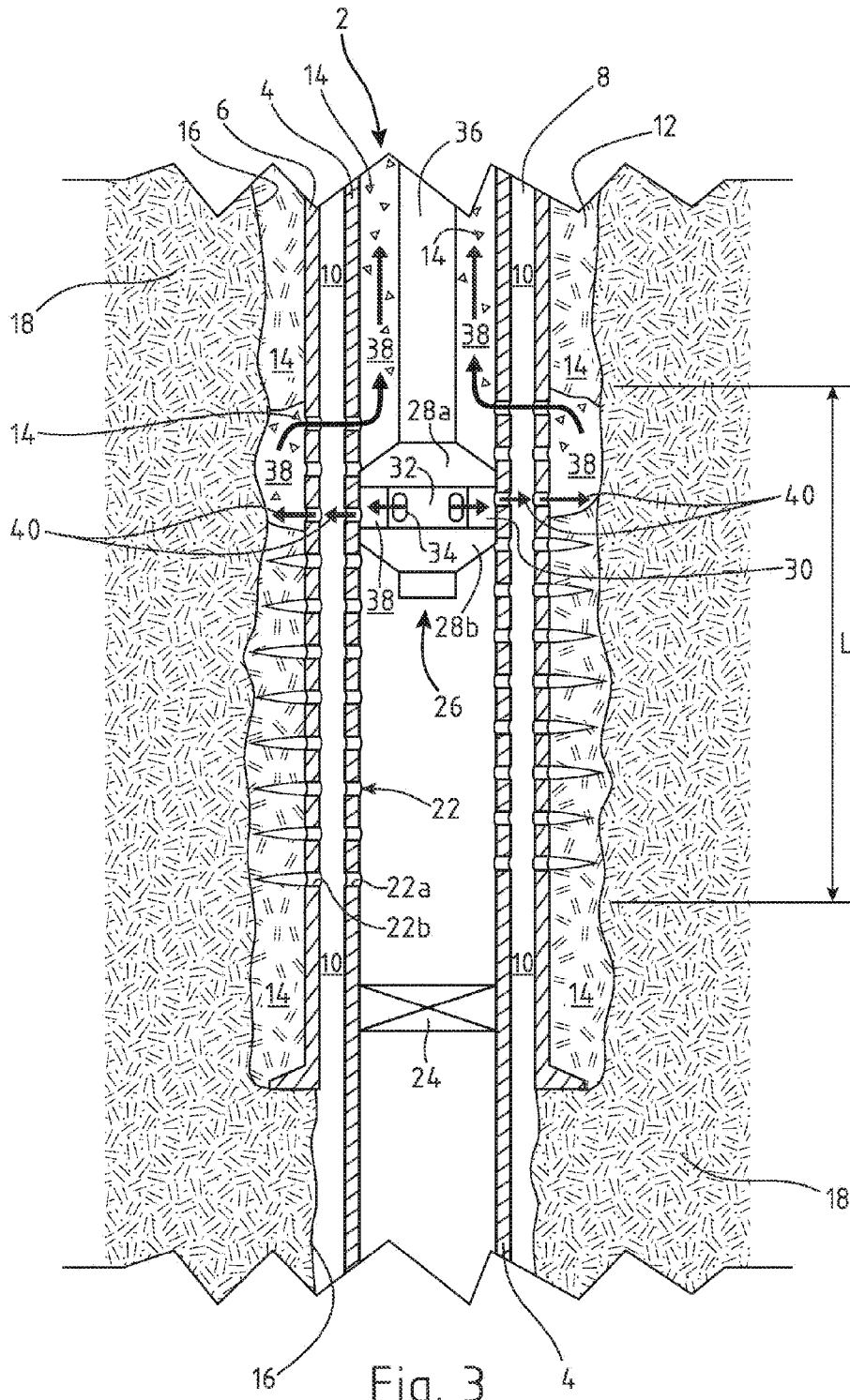

Fig. 3

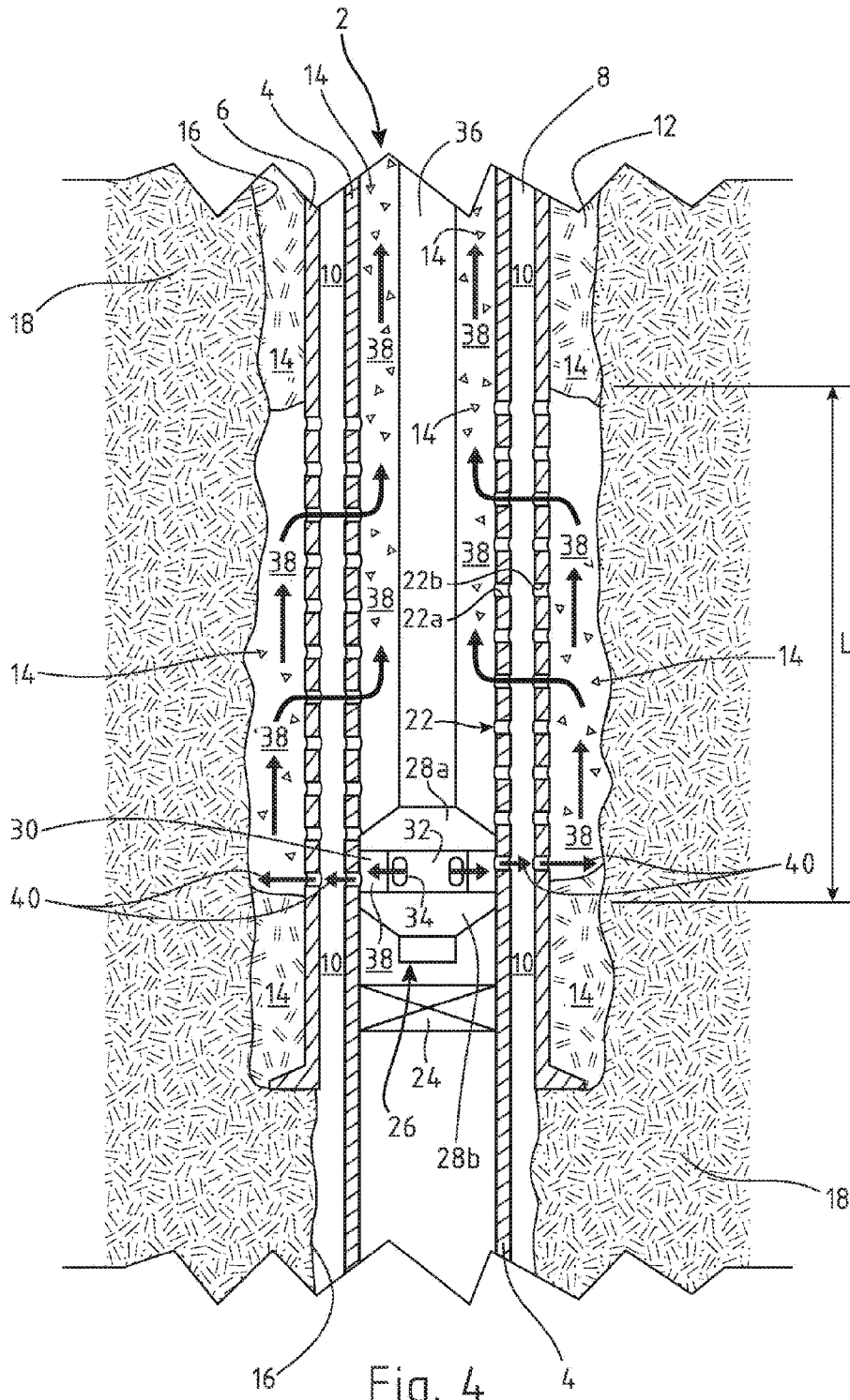

Fig. 4

