

J. ALLONAS.
 Threshing Machine.

No. 109,482.

Patented Nov. 22, 1870.

Fig. 1.

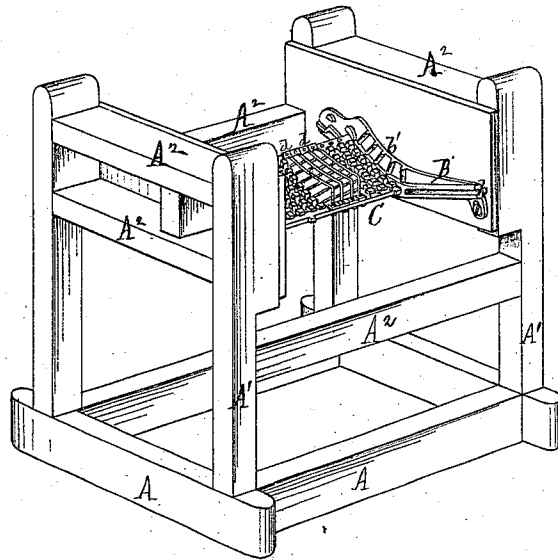

Fig. 2.

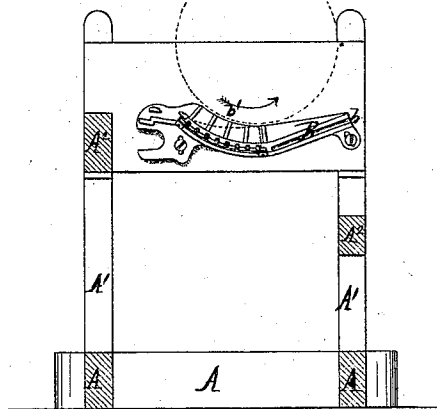
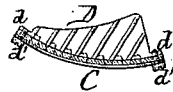

Fig. 3.



Witnesses.
 Alex. Mahon
 H. H. Doubleday

Joseph Allonas
 by his Attorney
 A. M. Smith

United States Patent Office.

JOSEPH ALLONAS, OF MANSFIELD, OHIO.

Letters Patent No. 109,482, dated November 22, 1870.

IMPROVEMENT IN THRASHING-MACHINES.

The Schedule referred to in these Letters Patent and making part of the same.

To all whom it may concern:

Be it known that I, JOSEPH ALLONAS, of Mansfield, county of Richland and State of Ohio, have invented certain new and useful Improvements in Thrashing-Machines, of which the following is a full, clear, and exact description, reference being had to the accompanying drawing making a part of this specification, in which—

Figure 1 is a perspective view of my improvement.

Figure 2 is a vertical transverse section, showing, in dotted lines, the relative position of the thrashing-cylinder and the teeth of the concave.

Figure 3 is a detached view, showing the manner of attaching the teeth to the concave.

The invention consists in—

First, combining with a reticulated or perforated concave triangular teeth, having their upper or working-edges hollowed out or concave, and their sides ribbed or roughened.

Second, in providing the grooved sector-pieces, which support the sections of concave, with radial ribs or spurs, whereby they are made to assist in the separation of the grain; and

Third, in a novel manner of supporting the teeth in the concave in such a manner that they may be readily removed singly.

In the drawing—

A A represent the sills, A¹ A¹ the posts, and A² A² the girts, composing the frame upon which the cylinder and concave are supported.

B is a sector-plate, grooved, as at *b*, for the reception of the ends of the concave sections.

This plate is provided with ribs, *b'*, running at about right angles to the groove *b*.

Instead of ribs *b'*, spurs may be employed, or any other means of roughening the surface of these plates, without departing from the spirit of my invention.

Plate B may be adjustably secured to frame A A¹ A², in any desired manner, there being, of course, one plate at each end of the concave.

C is a section of the concave.

It is perforated or reticulated, as shown in the drawing, and grooved transversely for the reception of the lower edges of the teeth D.

These teeth are triangular in form, being convex upon their lower edge, as is plainly shown in fig. 3, in order to fit accurately the upper face of the section C, and concave upon their upper edge, for a purpose which will presently be explained.

Each tooth is expanded at its lower corners, and formed into flanges, as at *d*, figs. 1 and 3, these flanges fitting a rib or ledge which extends along each side of the section C, in front and rear of the grooved and reticulated portion of said section, the teeth being firmly secured in place by means of screws, *d'*.

The vertical faces or sides of the teeth D are ribbed, corrugated, or otherwise roughened, for the purpose of facilitating the separation of the grain from the straw.

In operating my thrasher, the cylinder (represented by dotted lines in fig. 2) is driven rapidly in the direction indicated by the arrow in this figure. As the straw is drawn in, it at first moves easily over the upper edges of the teeth, the gradual rise of the curves offering but little resistance to the advancing straw, until it (the straw) reaches the rear end of the tooth, when it is suddenly driven down between them with a sharp blow.

As thrashers are ordinarily constructed, more or less grain will slip through between the outer row of cylinder-teeth and the inclosing-frame or sides, without being properly thrashed, and, in order to remedy this difficulty, I form the ribs *b'* upon sector-plates B.

Having now described my invention,

What I claim as new, and desire to secure by Letters Patent, is—

1. The combination of the reticulated concave section C and the triangular teeth D, having their upper or working-edges made concave in form, substantially as described.

2. The combination of the grooved concave section C, the teeth D, provided with flanges *d*, and the bolts *d'*, substantially as described.

JOSEPH ALLONAS.

Witnesses:

JOEL MYERS,
H. D. KEITH.