

(19) World Intellectual Property Organization
International Bureau



(43) International Publication Date
23 October 2003 (23.10.2003)

PCT

(10) International Publication Number
WO 03/086770 A1

- (51) International Patent Classification⁷: **B41J 2/175**, B81B 7/02, 7/04
- (21) International Application Number: PCT/AU02/00764
- (22) International Filing Date: 13 June 2002 (13.06.2002)
- (25) Filing Language: English
- (26) Publication Language: English
- (30) Priority Data: 10/120,430 12 April 2002 (12.04.2002) US
- (71) Applicant (for all designated States except US): **SILVERBROOK RESEARCH PTY. LTD.** [AU/AU]; 393 Darling Street, Balmain, New South Wales 2041 (AU).
- (72) Inventor; and
- (75) Inventor/Applicant (for US only): **SILVERBROOK, KIA** [AU/AU]; Silverbrook Research Pty Ltd, 393 Darling Street, Balmain, New South Wales 2041 (AU).
- (74) Agent: **SILVERBROOK, KIA**; Silverbrook Research Pty Ltd, 393 Darling Street, Balmain, New South Wales 2041 (AU).
- (81) Designated States (national): AE, AG, AL, AM, AT, AU, AZ, BA, BB, BG, BR, BY, BZ, CA, CH, CN, CO, CR, CU, CZ, DE, DK, DM, DZ, EC, EE, ES, FI, GB, GD, GE, GH, GM, HR, HU, ID, IL, IN, IS, JP, KE, KG, KP, KR, KZ, LC, LK, LR, LS, LT, LU, LV, MA, MD, MG, MK, MN, MW, MX, MZ, NO, NZ, OM, PH, PL, PT, RO, RU, SD, SE, SG, SI, SK, SL, TJ, TM, TN, TR, TT, TZ, UA, UG, US, UZ, VN, YU, ZA, ZM, ZW.
- (84) Designated States (regional): ARIPO patent (GH, GM, KE, LS, MW, MZ, SD, SL, SZ, TZ, UG, ZM, ZW), Eurasian patent (AM, AZ, BY, KG, KZ, MD, RU, TJ, TM), European patent (AT, BE, CH, CY, DE, DK, ES, FI, FR, GB, GR, IE, IT, LU, MC, NL, PT, SE, TR), OAPI patent (BF, BJ, CF, CG, CI, CM, GA, GN, GQ, GW, ML, MR, NE, SN, TD, TG).

[Continued on next page]

(54) Title: HIGH VOLUME PAGEWIDTH PRINTING

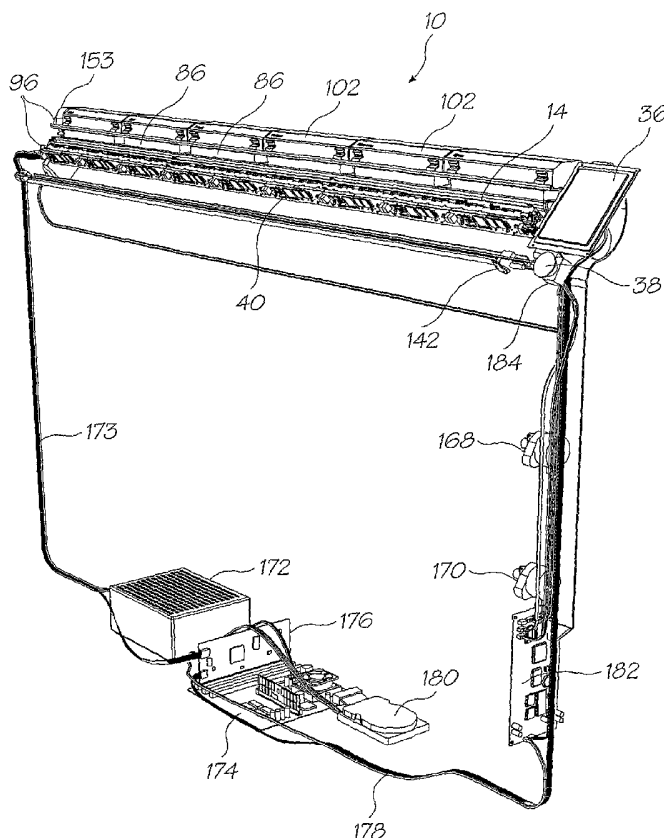

(57) Abstract: A print assembly (14) for pagewidth inkjet printing that includes an elongate carrier that is mountable on a support structure (12) of a printer (10) in an operative position with respect to a platen (106, 108) of the printer. A number of printhead chips (186) are positioned on the carrier. The print head chips together define a print head that is configured to eject at least one billion drops per second into a printing zone defined between the print head and the platen of the printer. Control circuitry is also positioned on the carrier and is configured to control operation of the print head chips.



WO 03/086770 A1



Published:

— *with international search report*

For two-letter codes and other abbreviations, refer to the "Guidance Notes on Codes and Abbreviations" appearing at the beginning of each regular issue of the PCT Gazette.

HIGH VOLUME PAGEWIDTH PRINTING

FIELD OF THE INVENTION

This invention relates to high volume pagewidth printing. More particularly, this invention relates to a method of pagewidth printing and to a printer.

BACKGROUND OF THE INVENTION

High volume, high resolution printing is an objective that has been sought by the manufacturers of wide format printers for some time. Wide format printers have been
10 available to the public for many years. Examples of popular wide format printers are the Hewlett Packard (HP) 1000/5000, the HP 3000/3500, the Epson 7000/10 000 and many others.

These printers all have a traversing printhead that traverses a print medium while depositing ink on the medium. Applicant believes that these printers suffer from inherent disadvantages, particularly when attempts are made to utilize the design of such printers in order to achieve faster printing speeds at high resolutions.

Central to the problem of achieving high printing speeds is the ability to achieve a printhead that is capable of generating the necessary number of ink dots at a suitable rate. Further, in order to achieve accurate printing, it is desirable that a row or band of the image
20 be created in as little print cycles as possible, and preferably in a single print cycle. It follows that it is undesirable for a traversing printhead to be used in an attempt to achieve high print speeds and that a single printhead incorporating a suitable number of inkjet nozzles is required.

Thermal printheads also referred to as bubble jet printheads and piezoelectric printheads have been available for some time. These suffer from excessive heat build up and energy consumption and have therefore been found by the applicant to not be suitable for use in a pagewidth configuration. A number of disadvantages associated with such printheads are set out in US application no 09/526,504.

The applicant has developed a printhead chip that is capable of producing images
30 having a resolution as high as 1600 dpi. These chips are manufactured using integrated circuit fabrication techniques. Details of the chips are provided in the above referenced applications and patents. Applicant believes that these printhead chips are extremely suitable for use in wide format printers. The reason for this is that such chips operate at

extremely high speeds due to the large number of nozzle arrangements required in a single chip and due to the fact that such chips can be driven at an extremely high cyclical rate.

The Applicant has been faced with a number of difficulties in order to achieve the effective use of such printhead chips in wide format printers. One particular difficulty identified by the Applicant is the effective control of a number of such printhead chips to achieve accurate printing.

SUMMARY OF THE INVENTION

According to a first aspect of the invention, there is provided a method of pagewidth
10 printing, the method comprising the steps of:

feeding a print medium through a printing zone; and

ejecting drops of ink at a rate of at least one billion drops per second from a print
assembly on to the print medium in the printing zone to generate an image on the print
medium.

According to a second aspect of the invention, there is provided a print assembly for
pagewidth inkjet printing, the print assembly comprising

an elongate carrier that is mountable on a support structure of a printer in an
operative position with respect to a platen of the printer;

a number of printhead chips that are positioned on the carrier, the printhead chips
20 together defining a printhead that is configured to eject at least one billion drops per second
into a printing zone defined between the printhead and the platen of the printer; and

control circuitry that is also positioned on the carrier and that is configured to
control operation of the printhead chips.

According to a third aspect of the invention, there is provided an inkjet printer that
comprises

a support structure;

a platen positioned in the support structure;

a print assembly positioned operatively with respect to the platen, the print
assembly comprising

30 an elongate carrier;

a number of printhead chips positioned on the carrier, the printhead chips
together defining a printhead that is configured to eject at least one billion drops per
second into a printing zone defined between the printhead and the platen; and

control circuitry that is also positioned on the carrier and that is configured to control operation of the printhead chips; and
a feed mechanism positioned on the support structure for feeding a print medium through the printing zone.

The invention is now described, by way of example, with reference to the accompanying drawings. The following description is not intended to limit the broad scope of the above summary.

BRIEF DESCRIPTION OF THE DRAWINGS

10 In the drawings,

Figure 1 shows a schematic, three-dimensional view of part of a printing mechanism of a print assembly, in accordance with the invention, of a printer, also in accordance with the invention;

Figure 2 shows a front view of the printing mechanism of Figure 1;

Figure 3 shows a rear view of the printing mechanism of Figure 1;

Figure 4 shows a three dimensional, external view of the printer;

Figure 5 shows a schematic, three-dimensional view of operative parts of the printer;

Figure 6 shows a schematic, exploded view of the printer;

20 Figure 7 shows a schematic, side sectioned view of a portion of the printer incorporating the print assembly;

Figure 8 shows an exploded view of an operative portion of the printing mechanism;

Figure 9 shows a cross sectional view of an operative portion of the printing mechanism;

Figure 10 shows a high-level block diagram of a print engine controller of the printer;

Figure 11 shows an expanded block diagram of a page expansion unit of the print engine controller;

30 Figure 12 shows a block diagram of the print engine controller incorporating the page expansion unit;

Figure 13 shows a schematic, three-dimensional view of part of a printhead chip of the print assembly of the printer, showing one nozzle arrangement of the printhead chip; and

Figure 14 shows a schematic, three-dimensional view of a printhead module that incorporates a printhead chip.

DETAILED DESCRIPTION OF THE INVENTION

In Figure 4, reference numeral 10 generally indicates a printer, in accordance with the invention.

10 The printer 10 has a support structure 12 that supports a print assembly 14 above a substrate. The support structure 12 includes a pair of spaced feet 16 and a leg 18 extending from each foot 16. The print assembly 14 is mounted on the legs 18 to span the legs 18.

A media tray 20 is positioned between the legs 18. The media tray 20 is configured to store suitable print media, such as paper 22.

The paper 22 is fed from a media feed mechanism in the form of a media roll 166 through the print assembly 14 and on to a take up spool 24. An electronics enclosure 26 is also positioned between the legs 18 to enclose various electronic components that are described below.

20 The print assembly 14 includes a lid 28, with a handle 30, and a front cover 32. The lid 28 and front cover 32 are positioned between a pair of end moldings 34.

The print assembly 14 also includes a color TFT LCD 36 with touch screen navigation. A stop button 38 is also provided to enable a user to stop operation of the print assembly 14.

The print assembly 14 and its various components are shown in further detail in the remaining Figures.

In Figures 1 to 3, reference numeral 40 generally indicates a printing mechanism of the print assembly 14. As can be seen in the drawings, the printing mechanism 40 is segmented. In particular, the printing mechanism 40 includes nine printed circuit boards (PCB's) 42 connected to each other with corresponding connector blocks 44.

30 The printing mechanism 40 further includes a printhead 41 having seventy-two printhead modules 46. Each PCB 42 is configured to control eight printhead modules 46. It follows that nine PCB's 42 are provided. The printhead modules 46 are described in further detail below.

Each PCB 42 includes a print engine controller (PEC) 48. The PEC's 48 are also described in further detail below.

Each PCB 42 also includes memory chips in the form of 64 Mbit external DRAM chips 50. The DRAM chips 50 cooperate with the PEC 48 in a manner that is described below.

Further, each PCB 42 includes a quality authentication (QA) chip 52. Details of a suitable QA chip are set out in the above referenced United States application no. 09/113,053 and are therefore not set out in this description. The QA chip 52 serves to inhibit unauthorized refilling of ink in the manner described in 09/113,053, in addition to
10 other functions such as ensuring the quality of print media used with the printer 10.

An endmost PCB 42 includes a serial connector 54 that permits serial data cables 56 to be connected to the PCB's 42.

Each PCB 42 is connected to its associated printhead modules 46 with a flexible PCB 58.

The printing mechanism 40 includes a metal chassis 60 that extends between a pair of side moldings 61 that are positioned in the end moldings 34. The PCB's 42 are mounted on the chassis 60. The chassis 60 has a generally U-shaped cross section. A channel 62 of an Invar alloy is positioned on the chassis 60.

A chassis molding 64 of a plastics material is positioned on an outside of the chassis
20 60 and the channel 62. Each PCB 42 is mounted on the chassis molding 64.

The chassis molding 64 defines a pair of recesses 66 on an outer side of the chassis molding 64. The recesses 66 extend a length of the chassis molding 64. A busbar 68 is positioned in each recess 66. The busbars 68 are configured to supply electrical power to the PCB's 42.

An ink reservoir assembly 70 is positioned in the Invar channel 62. The ink reservoir assembly 70 includes an ink distribution arrangement 72. Each printhead module 46 is positioned on a respective ink distribution arrangement 72. In particular, each printhead module 46 is removably mounted on its ink distribution arrangement 72 to facilitate removal and replacement when necessary.

30 The ink reservoir assembly 70 includes a plurality of ink reservoir moldings 76. Each ink reservoir molding 76 corresponds with an associated printhead module 46. The ink reservoir moldings 76 are positioned end-to-end along and within the Invar channel 62. Each ink reservoir molding 76 defines a plurality of elongate ink channels 74, each

accommodating a differently colored ink. Thus, effective elongate ink channels extend a length of the Invar channel 62.

An end cap molding 78 is positioned on an endmost ink reservoir molding 76. The end cap molding 78 has a plurality of connectors 80 defined thereon and in alignment with respective ink channels 74 when the end cap molding 78 is positioned on said endmost ink reservoir molding 76. The connectors 80 are connectable to an ink hose connector 82. The ink hose connector 82 is, in turn, connected to each of a plurality of ink hoses 84. It follows that each hose 84 is in fluid communication with a respective ink channel 74. Each hose 84 supplies the ink reservoir assembly 70 with ink of a particular color. For example, the hoses
10 84 can carry Cyan (C), Magenta (M), Yellow (Y) and Black (K) inks, respectively. In this case, four hoses 84 are provided. Also, each reservoir molding 76 defines four ink channels 74. Alternatively, the hoses 84 can carry Cyan (C), Magenta (M), Yellow (Y), Red (R), Green (G) and Blue (B) inks, respectively. In this case, six hoses 84 are provided. Also, each reservoir molding 76 then defines six ink channels 74. Instead of six differently colored inks, the six hoses 84 can carry CMYK and Infrared (IR) inks and a fixative (F) for high speed printing so that the inks can dry rapidly.

Each hose 84 is connected to a respective ink container 86 (Figure 5), so that each hose 84 is connected between an ink container 86 and a particular ink channel 74. The hoses 84 are connected to their respective containers 86 with T-piece connectors 94 shown
20 in Figure 1.

The print assembly 14 includes a plurality of capping devices 88 that correspond with respective printhead modules 46. Each capping device 88 is displaceable between an operative position in which it serves to cap its respective printhead module 46, to inhibit drying of ink, and an inoperative position in which ink can be ejected from the printhead module 46. A camshaft 90 is positioned in the chassis 60. A translating member 92 interconnects the camshaft 90 and the capping devices 88, so that rotational movement of the camshaft 90 results in reciprocal movement of the capping devices 88 between their operative and inoperative positions.

The camshaft 90 is driven with a suitable motor, indicated generally at 96 in Figure
30 5.

Further detail of the print assembly 14 is shown in Figure 7. As can be seen in this drawing, the front cover 32, the lid 28 and a rear cover 98 together define a housing 100 for the print assembly 14.

A plurality of ink cartridges 102 is positioned beneath the lid 28. Each ink cartridge 102 stores one of the inks mentioned above. Each ink cartridge 102 is positioned between a pair of clips 104 so that it can be replaced when necessary. Each ink cartridge 102 and a respective ink reservoir 86 are in fluid communication with each other, when the ink cartridge 102 is received between the clips 104.

A pair of platens, in the form of an upper platen 106 and a lower platen 108 is positioned within the housing 100. A pair of spaced primary rollers in the form of an upper primary roller 110 and a lower primary roller 112 is provided to displace the paper 22 through the print assembly 14. The upper roller 110 is positioned at an upper end of the platens 106, 108, while the lower roller 112 is positioned between the platens 106, 108. The rollers 110, 112 are configured to drive a sheet of the paper 22 over, consecutively, an inner surface of the lower platen 108 and an outer surface of the upper platen 106. Thus, the paper 22 passes over the upper roller 110, while the lower roller 112 is positioned between upwardly and downwardly moving portions of the paper 22.

A brush 114 is pivotally mounted at 116 to the housing 100. The brush 114 has an arcuate transverse profile that corresponds with the upper primary roller 110. The brush 114 is positioned in the housing 100 so that the paper 22 can pass between the brush 114 and the housing 100.

A pinch roller 118 is positioned downstream of the brush 114 to bear against the upper primary roller 110. Thus, when the paper 22 is displaced from between the brush 114 and the upper primary roller 110, the pinch roller 118 retains the paper 22 against lateral movement.

The upper platen 106 defines an upper printing zone 120 and a lower cutting zone 122. A gap 124 is defined between the upper and lower printing zones 120, 122. A plurality of spiked wheels 126 is partially received through the gap 124 to engage the paper 22 and the lower primary roller 112. A crossbar 128 is operatively positioned with respect to the spiked wheels 126 to retain the spiked wheels 126 in position. The spiked wheels 126 and the pinch roller 118 are configured so that a suitable tension is set up in the paper 22 when the paper 22 passes over the printing zone 120 of the upper platen 106.

The chassis 60 and channel 62 are positioned above the printing zone 120 of the upper platen 106. The chassis 60 and the channel 62 are connected to a displacement mechanism 129 so that the chassis 60 and channel 62 can be displaced from the printing zone 120 when necessary. In particular, the chassis 60 and channel 62 are displaceable

between an operative position in which the printhead modules 46 are a distance from the printing zone 120 that is suitable for printing and an inoperative position in which the paper 22 can be released from the printing zone 120.

The chassis 60 and channel 62 are connected to the pinch roller 118 with suitable metalwork 130. Further, the chassis 60 and channel 62 are connected to the crossbar 128. It follows that, when the displacement mechanism 129 is operated, the pinch roller 118 and the spiked wheels 126 are displaced from the upper platen 106 together with the chassis 60 and the channel 62.

10 The displacement mechanism 129 includes a camshaft 132 and a pusher 134. The pusher 134 is connected to the chassis 60 and the channel 62 so that, upon rotation of the camshaft 132, the chassis 60 and channel 62 are displaced towards and away from the printing zone of the upper platen 106.

Upper idler rollers 136 are rotatably mounted above the upper platen 106 so that the paper 22 is received between the upper platen 106 and the upper idler rollers 136.

A lower, sprung idler roller 138 is mounted on the lower platen 108 to be partially received through a gap 140 defined in the lower platen 108. The sprung idler roller 138 is configured and positioned to bear against the lower primary roller 112. Thus, an upwardly moving portion of the paper 22 is gripped, and passes between, the lower primary roller 112 and the sprung idler roller 138.

20 The print assembly 14 includes a cutting mechanism 142 that is mounted in the housing 100 above the cutting zone 122 of the upper platen 106. The cutting mechanism includes a cutter 146 that traverses the paper 22 to cut the paper 22. The cutting mechanism 142 includes an optical sensor 144 so that the cutter 146 can be stopped when it reaches an end of a cutting stroke. The cutting zone 122 defines a cutting formation 148 that cooperates with the cutter 146 to facilitate cutting of the paper 22.

As can be seen in Figure 6, the print assembly 14 includes an air impeller 150 and a motor 152 to drive the air impeller 150. The air impeller 150 serves to generate an air current within the housing 100 for cooling purposes. An air filter 153 is also positioned in the housing 100 to filter the air passing through the housing 100. The air impeller 150 also
30 serves to generate the air current to a sufficient extent to minimize the build up of dust on the printhead modules 46.

As can further be seen in Figure 6, the primary rollers 110, 112 are connected to a gearbox 154 that is mounted on a bracket 156. The gearbox 154 and bracket 156 are

positioned on one of the legs 18 and covered with one of the end moldings 34. Thus, the primary rollers 110, 112 serve to drive the paper 22 through the print assembly 14.

A printhead bracket 157 is positioned in the housing 100 and extends between the legs 18. The printhead bracket 157 provides a support structure for the chassis 60 and channel 62. The printhead bracket 157 also provides a support structure for the upper idler rollers 136.

The housing 100 is shaped to define an opening 158 for passage of the paper 22 into and out of the print assembly 14. Feed rollers 162 are rotatably mounted on a tie bar 160 that extends between the legs 18. The feed rollers 162 are positioned so that the paper 22 passes over the feed rollers 162 when the paper is fed into the print assembly 14. The tie bar 160 also serves a structural purpose in that it provides structural rigidity to the printer 10.

Discharge rollers 164 are rotatably mounted on the upper platen 106. The discharge rollers 164 are positioned so that the paper 22 passes over the discharge rollers 164 when the paper 22 is fed from the print assembly 14.

Both the media roll 166 and the take up spool 24 are driven with a media roll drive motor 168 and a take up spool drive motor 170, respectively (Figure 5).

The printer 10 includes a power supply unit 172 that is positioned in the electronics enclosure 26. The power supply unit 172 is configured to be powered by either a 110V or 220V power supply. Further, the power supply unit 172 is configured so that up to 90Amps can be drawn from the power supply unit 172. The power supply unit 172 is connected with power cables 173 to various components of the printer 10, such as the various drive motors to supply the components with required operational energy.

The printer 10 includes an ATX motherboard 174 that is also positioned in the electronics enclosure 26. A printhead interface card 176 is mounted on the motherboard 174. The printhead interface card 176 is connected to the nine PCB's 42 with suitable data cables 178. Thus, conventional print data supplied to the interface card 176 from the motherboard 174 can be converted into a suitable form for reading by the various PCB's 42.

The printer 10 includes a hard drive unit 180. Conveniently, the hard drive unit 180 can have a capacity of 40 Gigabytes. This facilitates the storage of entire images to be printed. The hard drive unit 180 is connected to the motherboard 174 in a conventional fashion. The hard drive unit 180 is a conventional hard drive unit and is therefore capable

of storing images in any number of formats, such as the well-known JPEG format. The manner in which the image data is read from the hard drive unit 180 is also conventional. As is set out below, printing of the images is digitally controlled as a result of the printhead technology utilized in this invention. It follows that transferal of image data from the hard drive unit 180 to the PCB's 42, via the printhead interface card 176 can take place without the requirement of significant data transformation, in particular, without the requirement of digital to analogue signal conversion.

The interface card 176 is also connected to a motor and LCD controller PCB 182 to control operation of the various drive motors and the TFT LCD. Details of such control are set out in the above referenced applications and are therefore not provided in this description. The motor and LCD controller PCB 182 is connected to a cut off switch 184 that is, in turn, connected to the stop button 38 so that operation of the printer 10 can be halted.

As can be seen in Figure 14, the printhead modules 46 each include a printhead chip 186. The printhead chip 186 can be in the form of any of the printhead chips described in the above referenced applications/patents. Each printhead module 46 includes a carrier 187 in which the printhead chip 186 is positioned. The carrier 187 defines a suitable connection zone for the flexible PCB 58 associated with the printhead chip 186. Figure 13 shows a schematic diagram of part of a printhead chip 186 that is suitable for use in the printer 10. Each printhead module 46 includes what are known as on chip fiducials 258. The on chip fiducials 258 are essentially in the form of markers to facilitate accurate alignment of the printhead modules 46 in the print assembly 14.

The printhead chip 186 is described in detail in the above referenced US application no. 09/112,767 and will therefore not be described in such detail in this specification. Briefly, however, the chip 186 includes a wafer substrate 188. A CMOS drive circuitry layer 190 is positioned on the wafer substrate 188 and is connected to the flexible PCB 58.

A plurality of nozzle arrangements 210 is positioned on the CMOS drive circuitry layer 190. For the purposes of convenience, one such nozzle arrangement 210 is shown in Figure 13. The printhead chip 186 comprises a multiple replication of the nozzle arrangement 210 on the wafer substrate 188. As set out in the above referenced applications and patents, the printhead chip 186 is the product of an integrated circuit fabrication technique. Replication of components in order to achieve a product is a well-known feature

of such a fabrication technique. It follows that the printhead chip 186 can readily be understood by a person of ordinary skill in the field of chip fabrication.

Each nozzle arrangement 210 includes a thermal bend actuator 192 that is positioned on the CMOS layer 190 to receive an actuating signal from the CMOS layer 190. In particular, the thermal bend actuator 192 includes a support post 194 that is mounted on the CMOS layer 190 to extend from the CMOS layer 190. The thermal bend actuator 192 includes an actuator arm 196 that is fixed to, and extends from, the support post 194. The actuator arm 196 includes a heating layer 198 in the form of an electrical heating circuit of a material having a coefficient of thermal expansion that is such that the material is capable of performing useful work on a MEMS scale as a result of expansion upon heating. The heating layer 198 is positioned on a layer 200 of a material having a coefficient of thermal expansion that is less than that of the heating layer 198 defining the electrical heating circuit. The heating layer 198 is positioned intermediate the layer 200 and the substrate 188 so that the actuator arm 196 is bent away from the substrate 188 when a current is passed through the heating layer 198.

Nozzle chamber walls 202 are positioned on the CMOS layer 190. A roof wall 204 is positioned on the nozzle chamber walls 202. The nozzle chamber walls 202 and the roof wall 204 define a nozzle chamber 206. The roof wall 204 defines an ink ejection port 208 from which ink is ejected, in use.

A paddle member 212 is mounted on the actuator arm 196 to extend into the nozzle chamber 206. The paddle member 212 is configured and positioned in the nozzle chamber 206 so that, upon displacement of the actuator arm 196, as described above, ink is ejected from the nozzle chamber 206.

The actuator arm 196 is connected to the CMOS layer 190 through the support post 194 so that the heating layer 198 can receive an electrical signal from the CMOS layer 190.

As can be seen in Figures 3 and 9, the printhead chips 186 are each positioned at an angle with respect to a straight line running the length of the printing zone 120. This facilitates a measure of overlap at adjacent ends of the printhead chips 186 to ensure printing continuity.

It is clear from the above referenced United States applications and patents that a pagewidth printhead including printhead chips as described above can incorporate up to 84 000 nozzle arrangements. It follows that, by using the printhead chips 186, it is possible for the print assembly 14 to have over as many as 200 000 nozzle arrangements. It follows that

over 200 000 dots can be printed on the paper 22 in the printing zone 120. In one particular example, the seventy-two printhead chips 186 provide a print width of 57.6 inches with 552 960 nozzle arrangements 210.

The nozzle arrangements 210 of each chip 186 are positioned side-by-side in two rows in a staggered fashion. It follows that true 1600 dpi printing can be achieved with the printhead chips 186.

Each printhead chip 186 therefore includes 7680 nozzle arrangements 210. Each nozzle arrangement 210 is independently controlled by the PCB 42 to eject a 1-picolitre drop on demand. The integrated circuit fabrication technology used is based on Very Large
10 Scale Integration (VLSI) technology that is fully described in the above referenced applications and patents. As a result of the manufacturing techniques used, each nozzle arrangement 210 can be as little as 32 microns wide. This allows each printhead chip 186 to have a surface area as little as 21 mm².

The characteristics of each nozzle arrangement 210 are such that it is capable of being driven at a cyclical rate of up to 80 kHz by its associated PEC 48. This permits printing of up to 21.6 billion drops per second that provides thirty-five thousand square feet per hour at 1600 dpi.

Each printhead chip 186 is connected to its associated PCB 42 with the flexible PCB 58. It follows that each flexible PCB 58 is connected to the CMOS layer 190 of its
20 associated printhead chip 186.

Each PEC 48 is a page rendering engine application specific integrated circuit (ASIC) that receives input data relating to compressed page images from the printhead interface 176. The PEC 48 produces decompressed page images at up to six channels of bi-level dot data as output. It will be appreciated that each PEC 48 communicates with eight printhead chips 186 in this example. Each PEC 48 is capable, however, of communication with up to sixteen such printhead chips 186. In particular, each PEC 48 can address up to sixteen printhead chips in up to six color channels at 15 000 lines/sec. It follows that each PEC 48 allows for a 12.8-inch printhead width for full bleed printing of A3, A4 and letter pages.

30 Each PEC 48 is color space agnostic. This means that the PEC 48 can accept print data in any color. While each PEC 48 can accept contone data as CMYX or RGBX where X is an optional fourth channel, it can also accept contone data in any print color space. Additionally, each PEC 48 is configured to define a mechanism for arbitrary mapping of

input channels to output channels. The PEC 48 is also configured for combining dots for ink optimization and the generation of channels based on any number of other channels. In this example, data input is typically based on CMYK for contone printing, K for a bi-level input, fixative, and optional further ink channels. The PEC 48 is also configured to generate a fixative channel for fast printing applications.

Each PEC 48 is configured to be resolution agnostic. This means that each PEC 48 simply provides a mapping between input resolutions and output resolutions by means of various scale factors. In this example, the expected output resolution is 1600 dpi. However, the PEC 48 does not store any data to this effect.

10 Each PEC 48 is also configured to be page-length agnostic. Each PEC 48 operates a printing band at a time and a page can have any number of bands. It follows that a “page” can have any reasonable length.

Each PEC 48 defines an interface so that it can be synchronized with other PEC’s 48, as is the requirement with this invention. This allows a simple two-PEC solution for simultaneous A3/A4/Letter duplex printing. This also allows each PEC 48 to be responsible for the printing of only a portion of a page. It will be appreciated that combining synchronization functionality with partial page rendering allows multiple PEC’s to be readily combined for alternative printing requirements including simultaneous duplex printing, wide format printing, commercial printing, specialist high contone resolution printing, and printing applications where more than six ink channels are required.

20

The following table sets out the features of each PEC 48 and its associated benefits.

Table 1. Features and Benefits of PEC

Feature	Benefits
Optimized print architecture in hardware	30ppm full page photographic quality color printing from a desktop PC
0.18micron CMOS (>3 million transistors)	High speed Low cost High functionality
1.8 billion dots per second	Extremely fast page generation
15,000 lines per second at 1600 dpi	1.1 A4/Letter pages per PEC chip per second
1 chip drives up to 122,880 nozzles	Low cost page-width printers
1 chip drives up to 6 color planes	99% of printers can use 1 chip per page
Sophisticated internal memory buffering and caching	Only requires 1 external memory, leading to low cost systems
JPEG expansion	low bandwidth from PC low memory requirements in printer

Lossless bitplane expansion	high resolution text and line art with low bandwidth from PC (e.g. over USB)
Netpage tag expansion	Generates interactive paper
Stochastic dispersed dot dither	Optically smooth image quality No moire effects
Hardware compositor for 6 image planes	Pages composited in real-time
Dead nozzle compensation	Extends printhead life and yield Reduces printhead cost
Color space agnostic	Compatible with all inksets and image sources including RGB, CMYK, spot, CIE L*a*b*, hexachrome, YCrCbK, sRGB and other
Color space conversion	Higher quality / lower bandwidth
Computer interface agnostic	Works with USB1, USB2, IEEE1394 (Firewire), ethernet, IEEE1284 (Centronics)
Variable page length	Print any page length (up to 64 km)
Cascadable in resolution	Printers of any resolution
Cascadable in color depth	Special color sets e.g. hexachrome can be used
Cascadable in image size	Printers of any width
Cascadable in pages	Printers can print both sides simultaneously
Cascadable in speed	Very high speed printers can be built
Fixative channel data generation	Extremely fast ink drying without wastage
Built-in security	Revenue models are protected
Undercolor removal on dot-by-dot basis	Reduced ink usage
Does not require fonts for high speed operation	No font substitution or missing fonts
Flexible printhead configuration	Many configurations of printheads are supported by one chip type
Drives Memjet™ printheads directly	No print driver chips required, results in lower cost
Determines dot accurate ink usage	Removes need for physical ink monitoring system in ink cartridges

In Figure 10, there is shown a block diagram of the PEC 48. The PEC 48 includes a high-speed interface 214 through which an external micro controller 216 can write to the 64 Mbit DRAM chip 50. The PEC 48 also includes a low speed serial interface 220 through which the micro controller 216 can access registers of the PEC 48 and the DRAM chip 50.

The PEC 48 also includes a page expansion unit (PEU) 222 that receives data relating to compressed pages and renders it into data relating to bi-level dots. A line loader/formatter unit 224 is also provided that formats dots for a given print line destined

for a printhead interface 226 that communicates directly with the printhead chips 186 of each printhead module 46.

As can be seen, the PEC 48 performs three basic tasks. These are:

- a) Accepting register and DRAM access commands via the low speed interface 220 (or from the external DRAM chip 50).
- b) Accepting DRAM write accesses (typically compressed page bands and register command blocks) via the high speed interface 214.
- c) Rendering page bands from the external DRAM chip 50 to the printhead chips 186.

10 These tasks are independent. However, they do share the external DRAM chip 50. It follows that arbitration is required. The PEC 48 is configured so that DRAM accesses required for rendering page bands always have the highest priority.

The PEC 48 includes a PEC controller 228 that provides external clients with the means to read and write PEC registers, and read and write DRAM in single 32 bit data chunks.

The DRAM chip 50 is connected to an SDRAM controller 234. In turn, the SDRAM controller 234 is connected to a DRAM interface unit 236.

20 The PEC 48 includes a data bus 230 and a low speed serial bus 232. Both the SDRAM controller 234 and the DRAM interface unit 236 are connected to the low speed serial bus 232. The PEC controller 228 is connected to the data bus 230. The PEC controller 228 is also connected to the low speed serial bus 232 via the low speed interface 220. The high-speed interface 214, the PEU 222 and the line loader/formatter unit are also connected to the data bus 230.

In use, since the PEC 48 prints page bands from DRAM, a given band B is loaded into DRAM via the high-speed interface 214 before printing can begin. Then, while the PEC 48 is rendering band B via the PEU, band B+1 can be loaded to DRAM. While band B+1 is being expanded and printed, band B+2 can be loaded, and so on.

In the following table, the various components of the PEC 48 mentioned above are described briefly.

30 **Table 2. Units within PEC (high level)**

unit acronym	unit name	reference numeral	description
DIU	DRAM interface unit	236	Provides the interface for DRAM read and write

			access for the various PEC units. The DIU provides arbitration between competing units and passes on DRAM requests to the SCU.
HSI	High speed interface	214	Provides external clients (such as the microcontroller) with the means to write to DRAM.
LLFU	Line loader formatter unit	224	Reads the expanded page image from line store, formatting the data appropriately for the Memjet printhead.
LSI	Low speed interface	220	Provides external clients with the means to send commands to the PCU and receive register reads.
PCU	PEC controller	228	Provides external clients with the means to read and write PEC registers, and read and write DRAM in single 32-bit chunks.
PEU	Page expansion unit	222	Reads compressed page data and writes out the decompressed form of the same to DRAM.
PHI	Printhead interface	226	Is responsible for sending dot data to the Memjet printhead segments and for providing line synchronization between multiple PECs.
SCU	SDRAM controller unit	234	Provides the DIU with access to the external DRAM.

An expanded block diagram of the PEU 222 is shown in Figure 11. In the following table, the various components of the PEU 222 are described briefly.

Table 3. Units within Page Expansion Unit (high level)

unit acronym	unit name	reference numeral	description
CDU	Contone decoder unit	238	Expands JPEG compressed contone layer and writes decompressed contone to DRAM
CLBI	Contone line buffer interface	240	Provides line buffering between CRU and HCU
CRU	Contone reader unit	242	Reads expanded contone image from DRAM
DNC	Dead nozzle compensator	244	Compensates for dead nozzles by error diffusing dead nozzle data into surrounding dots.
DWU	Dotline writer unit	246	Writes out the 6 channels of dot data for a given printline to the line store DRAM
HCU	Halftoner compositor unit	248	Dithers contone layer and composites the bi-level spot 0 and position tag dots.

LBD	Lossless bilevel decoder	250	Expands compressed bi-level layer.
SLBI	Spot line buffer interface	252	Provides line buffering between LBD and HCU
TE	Tag encoder	254	Encodes tag data into line of tag dots.
TLBI	Tag line buffer interface	256	Provides line buffering between TE and HCU

A first stage in page expansion occurs along a pipeline defined by the CDU 238/CRU 242, the LBD 250 and the TE 254. The CDU 238 expands a JPEG-compressed contone (typically CMYK) layer. The LBD 250 expands a compressed bi-level layer (typically K), and the TE 254 encodes data tags for rendering (typically in infra-red ink) at a later stage. The CLBI 240, the SLBI 252 and the TLBI 256 receive output data from this stage.

The HCU 248 carries out a second stage. The HCU 248 dithers a contone layer and composites position tags and a bi-level spot0 layer over a resulting bi-level dithered layer.

10 A data stream generated by the HCU 248 is adjusted to create smooth transitions across overlapping segments or printhead chips 186. The HCU 248 is configured so that a number of options exist for the way in which compositing occurs. This stage can produce up to six channels of bi-level data. It should be noted that not all six channels might be present on the printhead chips 186. For example, the printhead chips 186 may be CMY only, with K pushed into the CMY channels and IR ignored. Alternatively, the position tags mentioned above may be printed in K if IR ink is not available or for testing purposes.

The DNC 244 carries out a third stage. In this stage, the DNC 244 compensates for dead nozzles in the printhead chips 186 by error diffusing dead nozzle data into surrounding dots.

20 Bi-level, six channel dot-data (typically CMYK-IRF) generated in the above stages is buffered and written out to a set of line buffers stored in the off-chip DRAM via the DWU 246.

In a final stage, the dot-data is loaded back from the DRAM, formatted for the printhead, and passed to the printhead interface 226 via a dot FIFO (not shown). The dot FIFO accepts data from the line loader/formatter unit 224 at pclk rate, while the printhead interface 226 removes data from the FIFO and sends it to the printhead chips 186 at a rate of either pclk/4, pclk/2 or pclk.

Figure 12 simply shows the PEC 48 incorporating the exploded PEU 222.

The printing benefits associated with the printhead chips 186 are set out in detail in the above referenced applications and patents. However, some benefits are particularly important when applied to wide printing formats.

A particular benefit is the high number of nozzle arrangements 210 per printhead chip 186. This facilitates extremely rapid printing in that a single print cycle can achieve an image band. It follows that it is not necessary for further print cycles to be used to fill in "missing" dots as is the case with a scanning printhead.

The PEC's 48 provide the necessary synchronized control of the printhead chips 186 as described above. Furthermore, as is clear from a number of the above referenced applications and patents, for example 09/113,053, the printhead chips 186 allow for the conversion from analogue printing processes to fully digital processes. This allows for a substantial amount of flexibility and speed. Digital control of the printhead chips 186 is by means of the PEC's 48. The fact that the PEC's 48 digitally control the printhead chips 186 allows for the high printing speed of up to 21.6 billion drops per second. In particular, the need for separate printhead chip drivers is removed, which is key to the high printing speed of the chips 186.

The incorporation of the CMOS layer 190 serves to integrate CMOS technology with MEMS technology on each printhead chip 186. It follows that at least one off-chip connection for each nozzle arrangement 210 is not required. It will be appreciated that such a requirement would make a printhead unreliable and cost-prohibitive to manufacture.

A further important advantage associated with the printer 10 is that a width of the printing zone 120 is extremely small when compared to the length. In a particular example, the printing zone 120 can be as little as 0.5 mm thick. It will be appreciated that it is necessary to achieve extremely stable paper movement through the printing zone 120 in order to ensure that accurate printing takes place in the printing zone. The narrow width of the printing zone 120 facilitates minimal control over the paper 22 as it passes through the printing zone.

In the event that a substantially wider printing zone were provided, it would be necessary to provide further control over movement of the paper 22 through such a printing zone. This would require such devices as vacuum platens to retain the paper 22 against any form of pivotal or lateral movement as the paper 22 moves through the printing zone. This could greatly increase the cost of the wide format printer.

This highlights some reasons why thermal or bubble jet and piezoelectric printheads would not be practical choices when attempting to achieve the printing characteristics of the printer 10. As set out in the above referenced applications and patents, such printheads are not suitable for providing the high density of nozzle arrangements achieved with the printheads of the above referenced matters. It follows that, in attempting to apply thermal and piezoelectric printheads to a wide format printer, it would be necessary to have a relatively wide printing zone so that overlapping of printheads could occur to the necessary extent. This would immediately raise the problem mentioned above. Still further, especially with the thermal printheads, a suitable cooling system would be required to keep the temperature in the printing zone at a reasonable level. This would also increase the cost to an unacceptably high level.

In order to achieve an appreciation of the speed of the printer 10 at a resolution of 1600 dpi, the following comparative table is set out below. It should be noted that the purpose of the following table is simply to illustrate the speed of printing and is not intended to denigrate the various printers used as comparators.

WIDE FORMAT PRINTERS - 100 TIMES FASTER

Memjet	OEM Printhead Print Width (inches)				38.4	44.8	51.2	57.6	64.0	70.4	76.8
	Number of Printhead Chips				48	56	64	72	80	88	96
	Number of Nozzles				368,640	430,080	491,520	552,960	614,400	675,840	737,280
	Max. print speed (sq ft/hr at 1600 x 1600 dpi)				17,578	20,508	23,438	26,367	29,297	32,227	35,156
Comparison	Make	Model	Resolution	Speed	Memjet Speed Advantage (# of times faster)						
	HP	1000 / 5000	600 x 600	120	146	171	195	220	244	269	293
	HP	3000 / 3500	600 x 300	72	244	285	326	366	407	448	488
	Epson	7000 / 10000	720 x 720	90	195	228	260	293	326	358	391
	Encad	Novajet 800	600 x 600	96	183	214	244	275	305	336	366
	Gretag	Arizona	Draft mode	444	40	46	53	59	66	73	79
	Gretag	Arizona	309 x 618	220	80	93	107	120	133	146	160
	Colorspan	Mach X11	600 x 600	115	153	178	204	229	255	280	306
	Canon	BJW 9000	600 x 1200	72	244	285	326	366	407	448	488
	Mutoh	Albatross	792 x 792	65	270	316	361	406	451	496	541
	Roland	HiFi Jet	720 x 720	96	183	214	244	275	305	336	366
	Nur	Fresco	360 x 360	300	59	68	78	88	98	107	117

As is known by those of skill in the fabrication of integrated circuits, while a set up cost for the manufacture of an integrated circuit device can be high, the cost of commercial manufacture of such devices is relatively low. It follows that Applicant envisages that the cost of manufacture of a wide format printer in accordance with this invention will be comparable to the cost of manufacture of the wide format printers listed in the above table.

WE CLAIM

1. A method of pagewidth printing, the method comprising the steps of:
feeding a print medium through a printing zone; and
ejecting drops of ink at a rate of at least one billion drops per second from a print assembly on to the print medium in the printing zone to generate an image on the print medium.
2. A method as claimed in claim 1, which includes the step of ejecting at least ten billion drops per second from the print assembly on to the print medium.
3. A method as claimed in claim 2, which includes the step of ejecting at least twenty billion drops per second from the print assembly on to the print medium.
4. A print assembly for pagewidth inkjet printing, the print assembly comprising an elongate carrier that is mountable on a support structure of a printer in an operative position with respect to a platen of the printer;
a number of printhead chips that are positioned on the carrier, the printhead chips together defining a printhead that is configured to eject at least one billion drops per second into a printing zone defined between the printhead and the platen of the printer; and control circuitry that is also positioned on the carrier and that is configured to control operation of the printhead chips
5. A print assembly as claimed in claim 4, in which the printhead chips together define a printhead that is configured to eject at least ten billion drops per second into the printing zone.
6. A print assembly as claimed in claim 5, in which the printhead chips together define a printhead that is configured to eject at least twenty billion drops per second into the printing zone.
7. A print assembly as claimed in claim 6, in which the printhead chips together incorporate at least one hundred thousand nozzle arrangements.

8. A print assembly as claimed in claim 7, in which the printhead chips together incorporate at least two hundred thousand nozzle arrangements.

9. A print assembly as claimed in claim 8, which includes between forty and one hundred printhead chips positioned on the carrier.

10. A print assembly as claimed in claim 4, in which each printhead chip is the product of an integrated circuit fabrication process.

10

11. A print assembly as claimed in claim 10, in which each printhead chip includes a wafer substrate and a CMOS drive circuitry layer positioned on the wafer substrate with the nozzle arrangements positioned on the wafer substrate and the CMOS drive circuitry layer.

12. A print assembly as claimed in claim 11, in which each nozzle arrangement is in the form of a micro electro-mechanical system that is electrically connected to the CMOS drive circuitry layer.

13. A print assembly as claimed in claim 12, which includes a plurality of printhead modules, each printhead module incorporating a printhead chip, the printhead modules being mounted on the carrier.

20

14. A print assembly as claimed in claim 13, in which a flexible printed circuit board is mounted on each printhead module and connected between the CMOS drive circuitry layer of each printhead chip and the control circuitry.

15. A print assembly as claimed in claim 14, in which the printhead modules are configured so that the printhead chips are each positioned at a common angle of greater than zero degrees and less than ninety degrees with respect to a line extending a length of the printing zone, so that consecutive printhead chips overlap at their ends.

30

16. An inkjet printer that comprises
a support structure;

a platen positioned in the support structure;
a print assembly positioned operatively with respect to the platen, the print assembly comprising

- an elongate carrier;
- a number of printhead chips positioned on the carrier, the printhead chips together defining a printhead that is configured to eject at least one billion drops per second into a printing zone defined between the printhead and the platen; and
- control circuitry that is also positioned on the carrier and that is configured to control operation of the printhead chips; and

10 a feed mechanism positioned on the support structure for feeding a print medium through the printing zone.

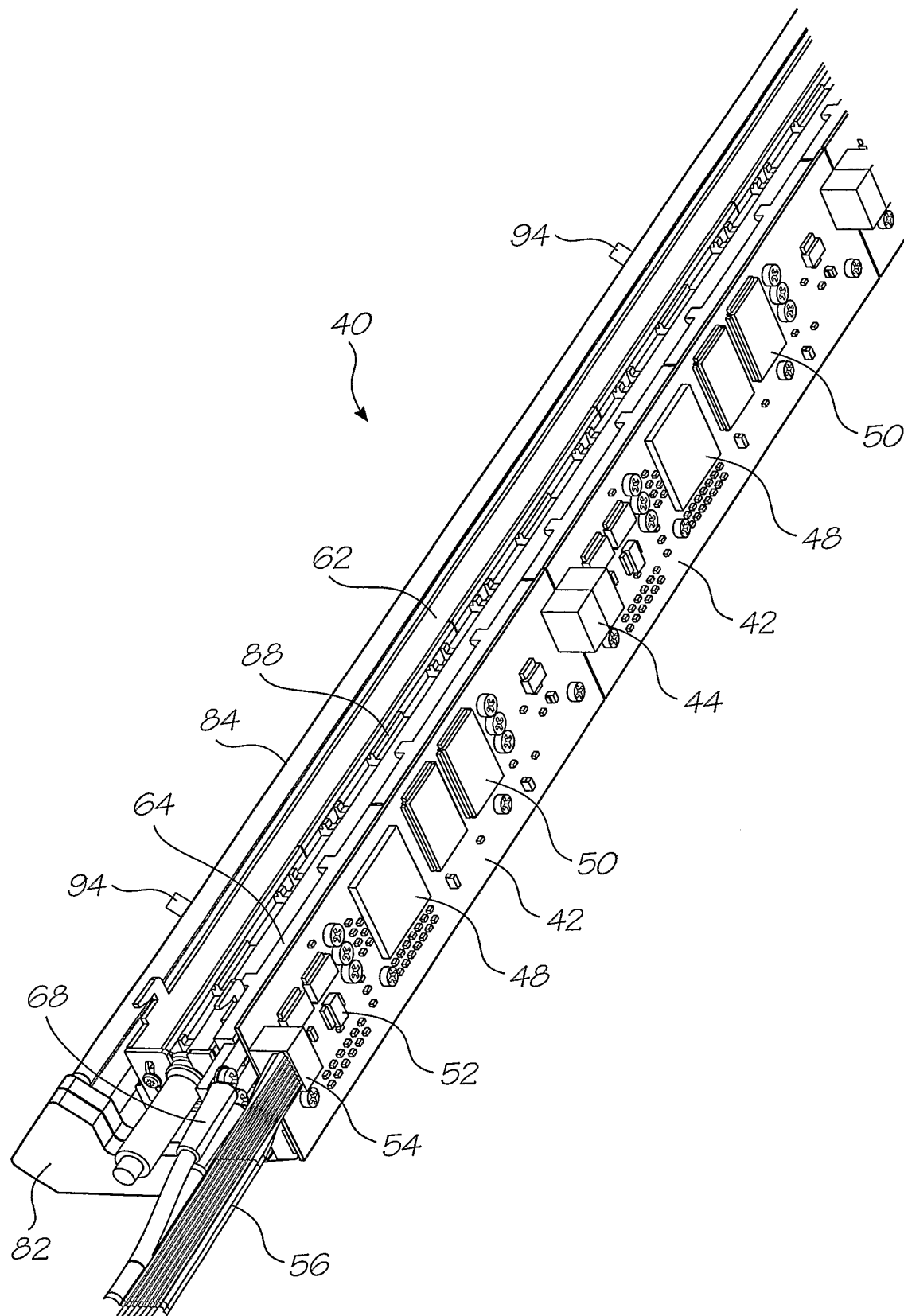

FIG. 1

2/14

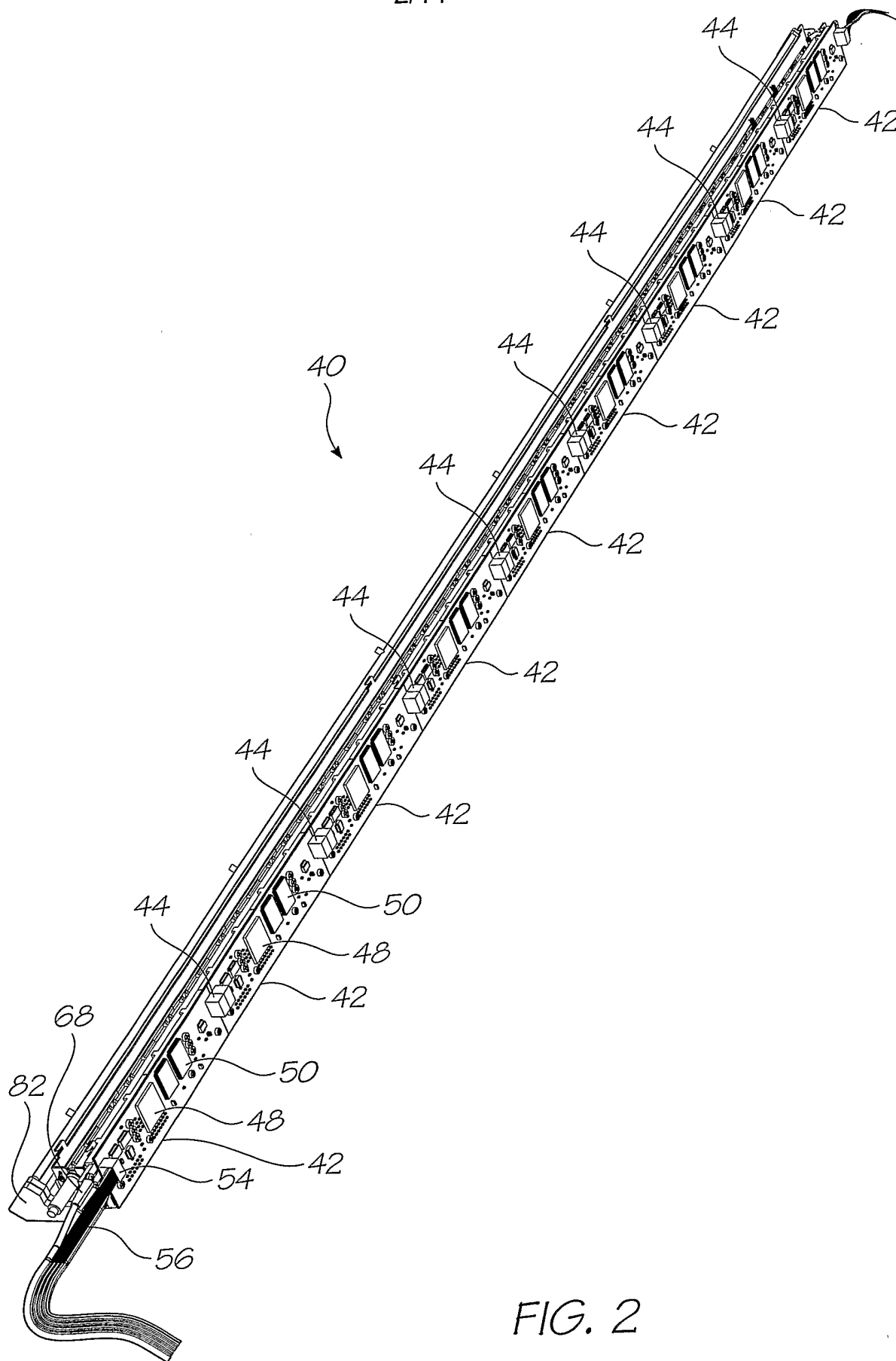

FIG. 2

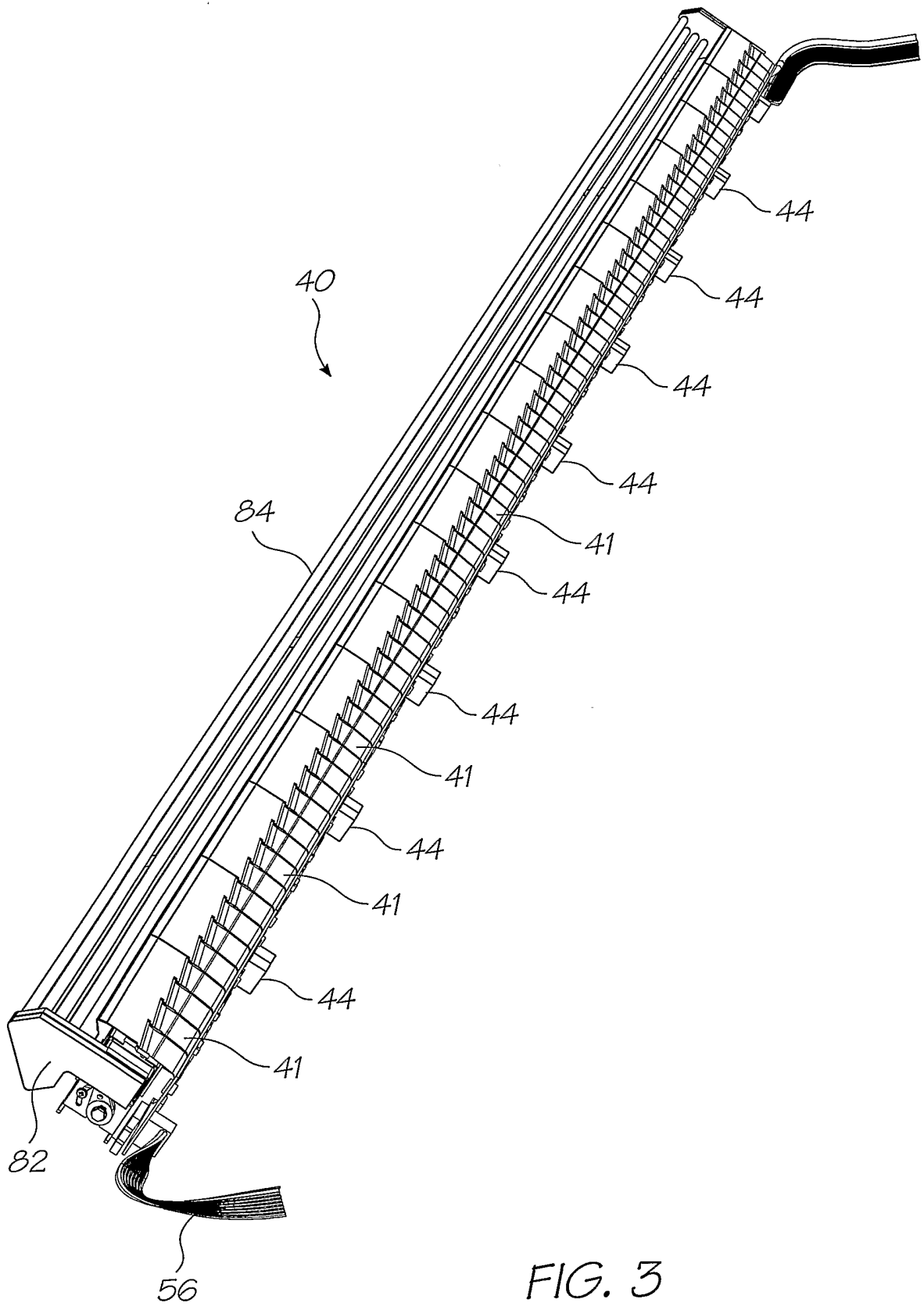

FIG. 3

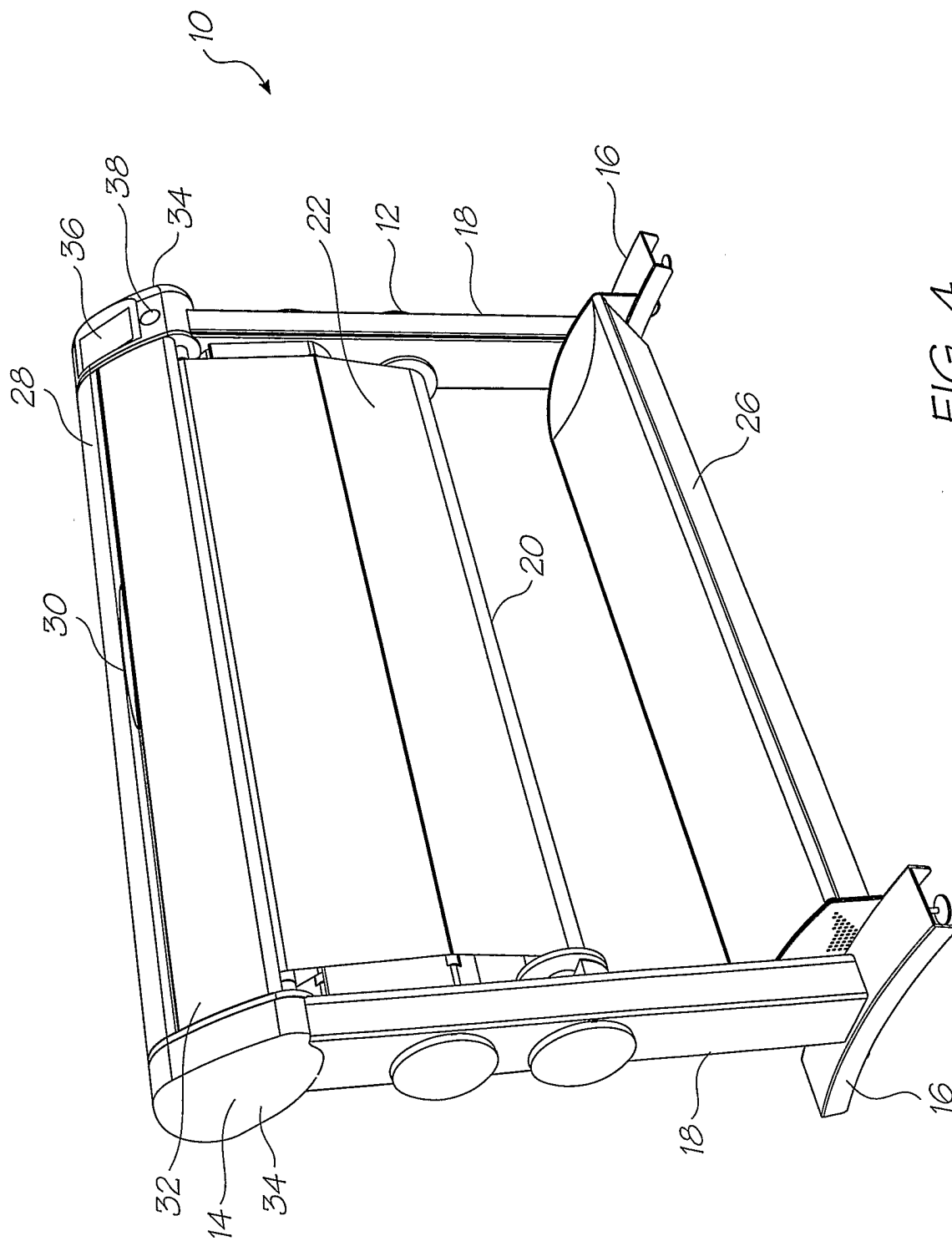

FIG. 4

5/14

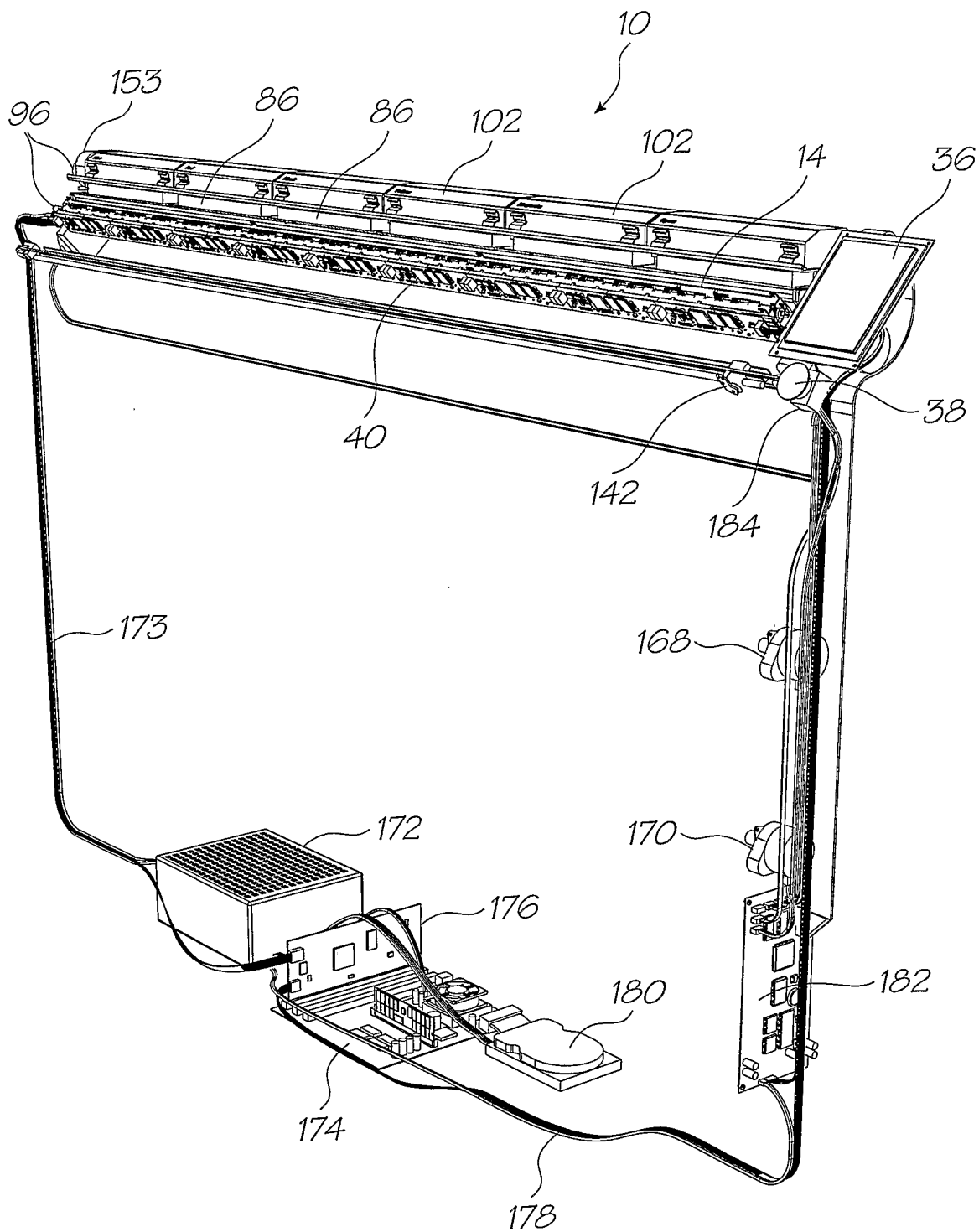

FIG. 5

6/14

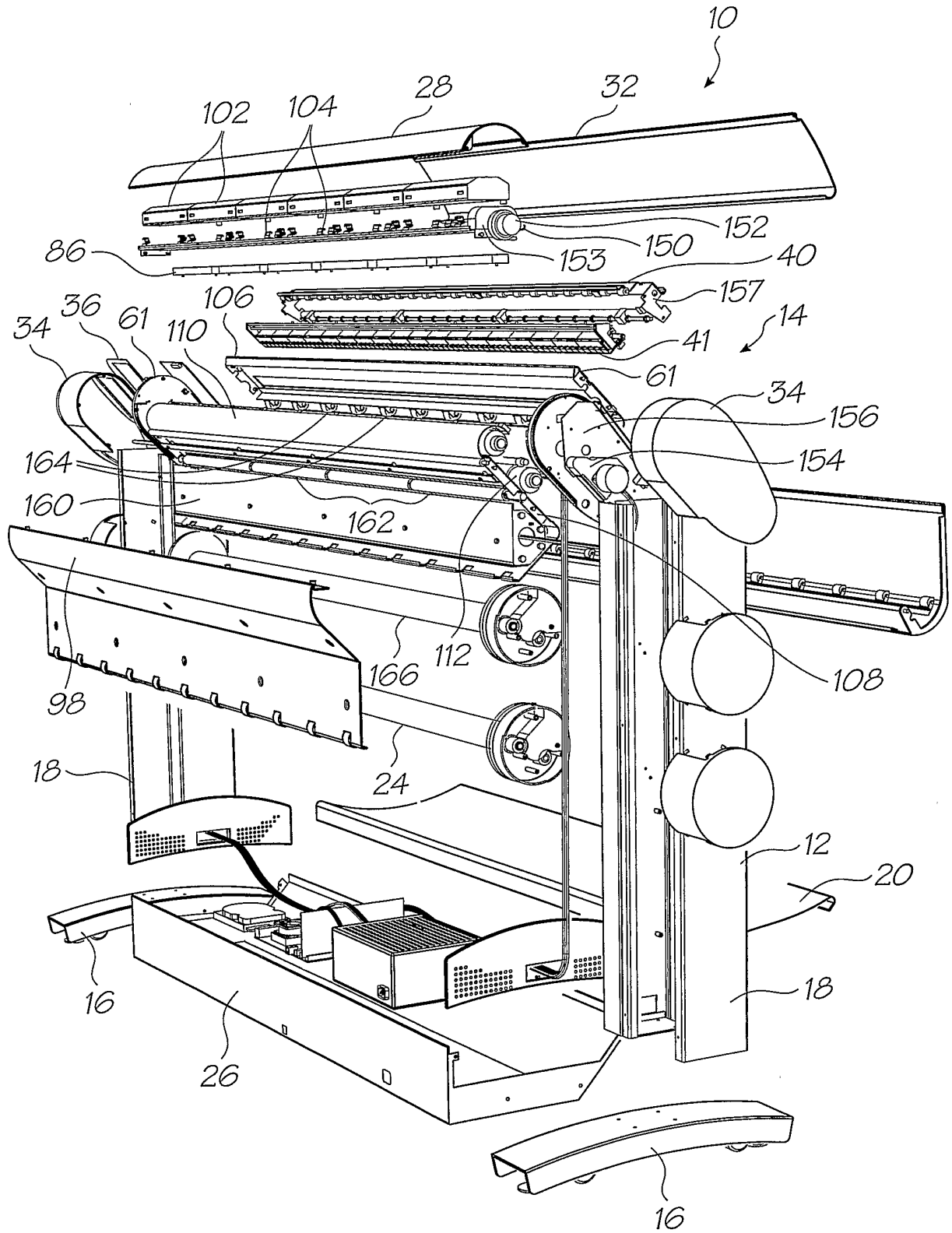

FIG. 6

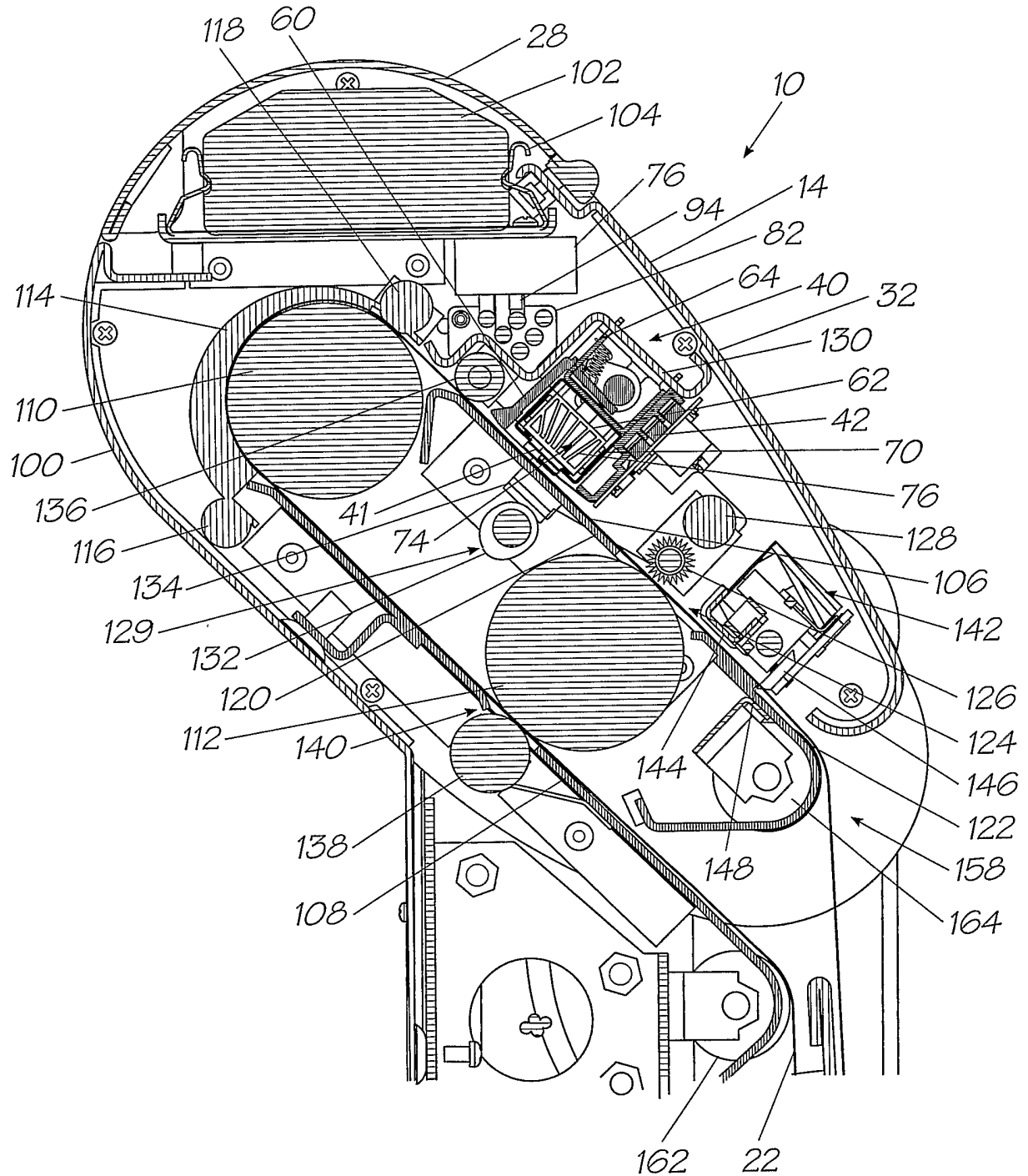

FIG. 7

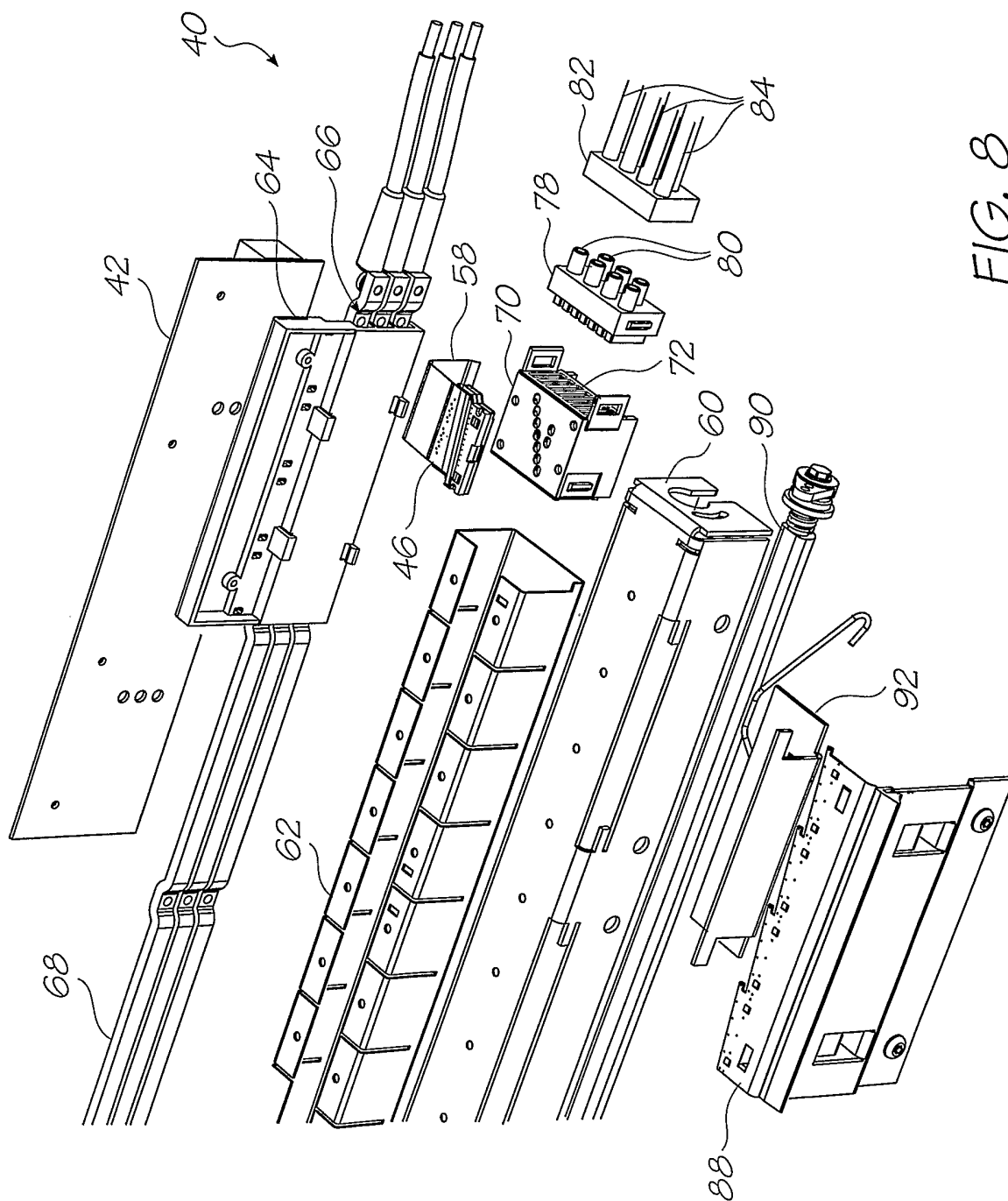

FIG. 8

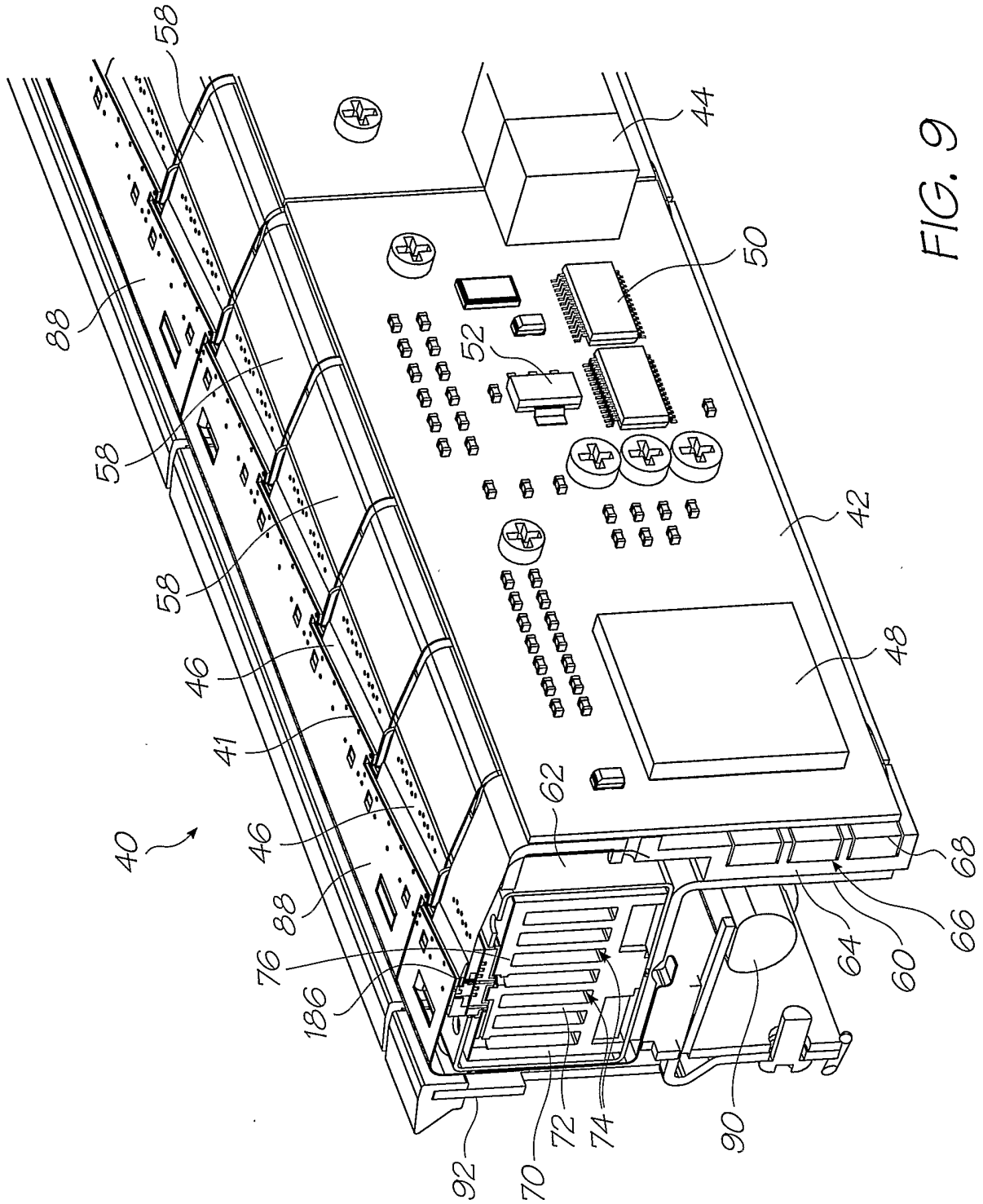

FIG. 9

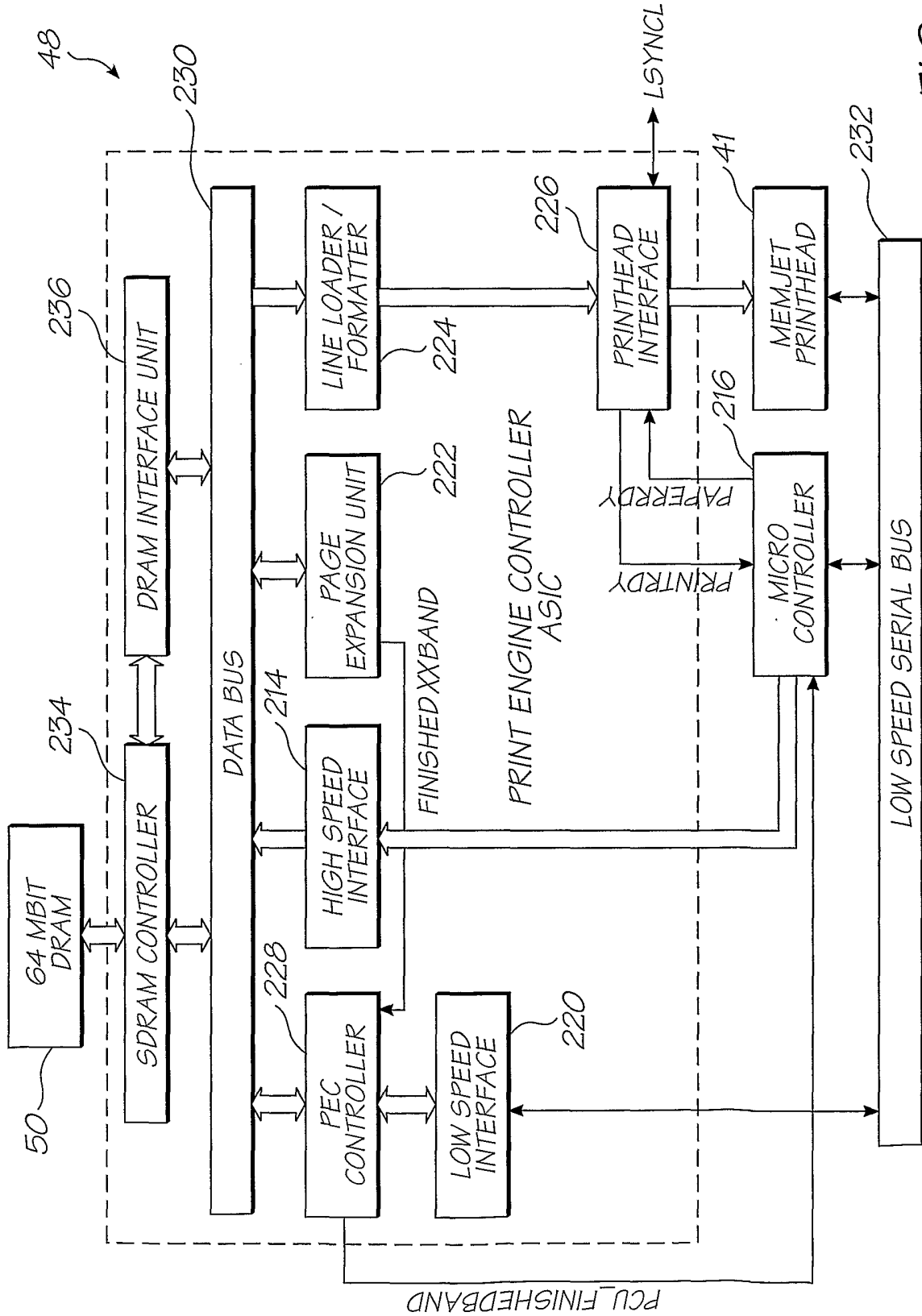

FIG. 10

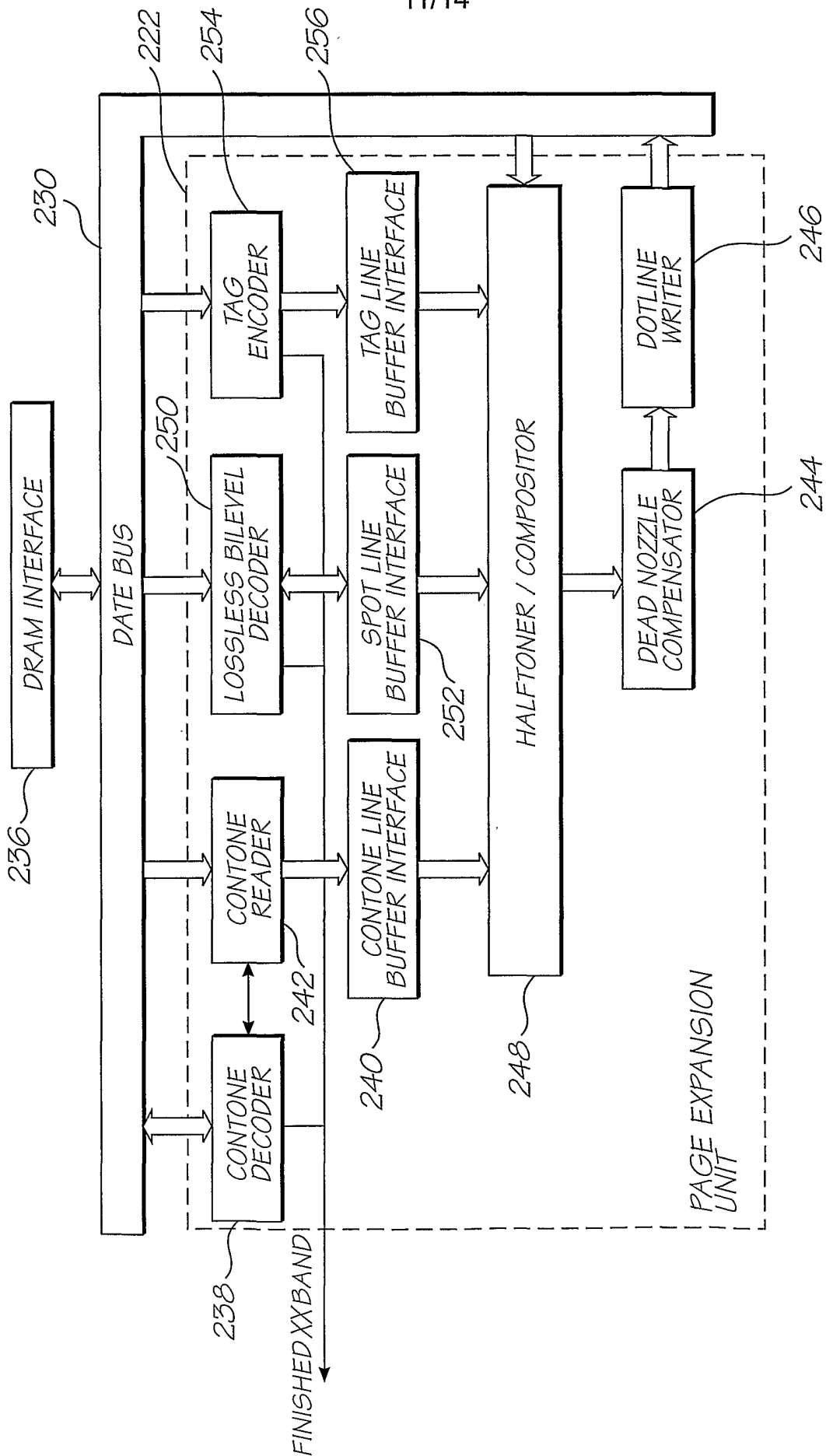

FIG. 11

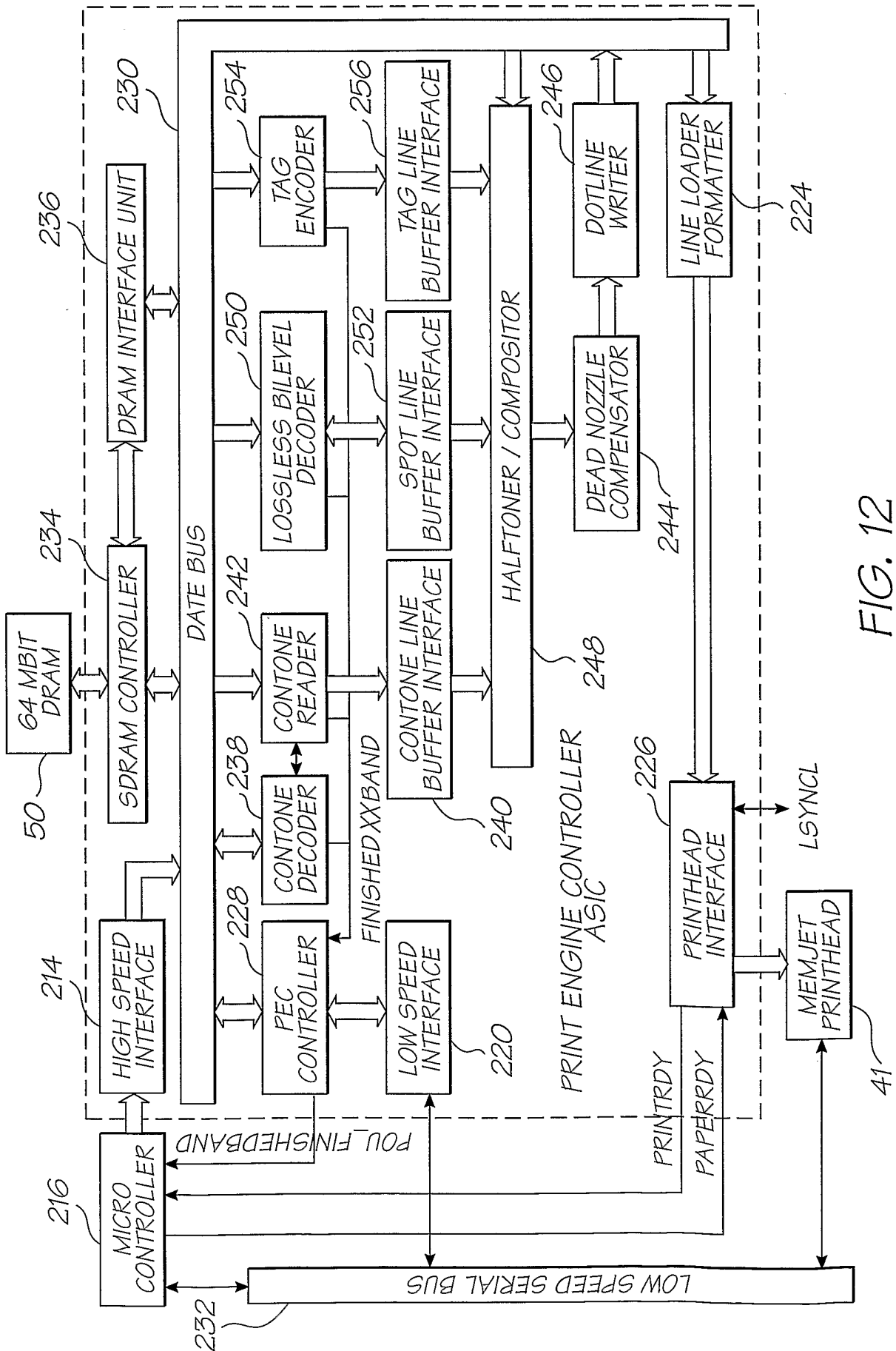

FIG. 12

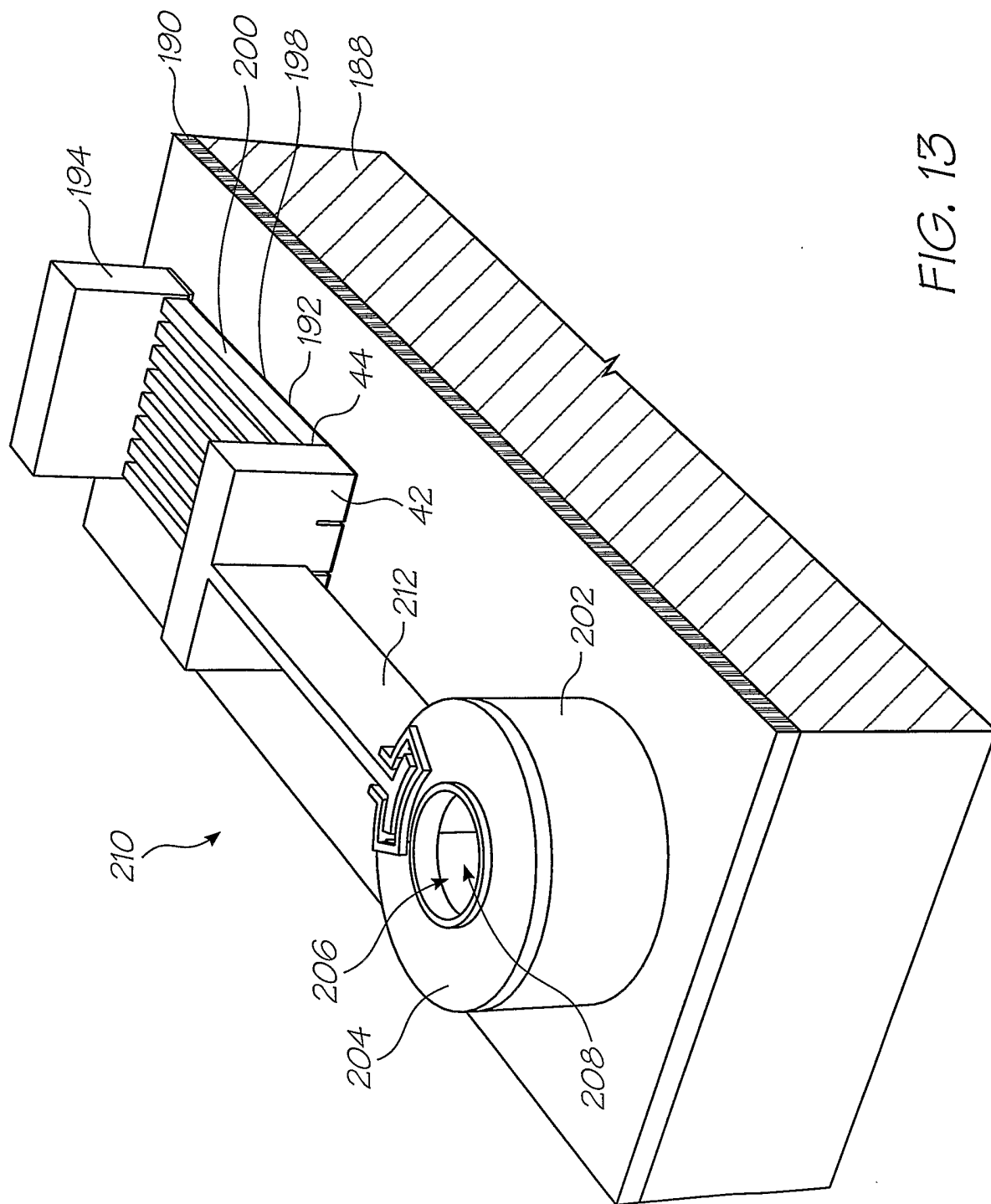

FIG. 13

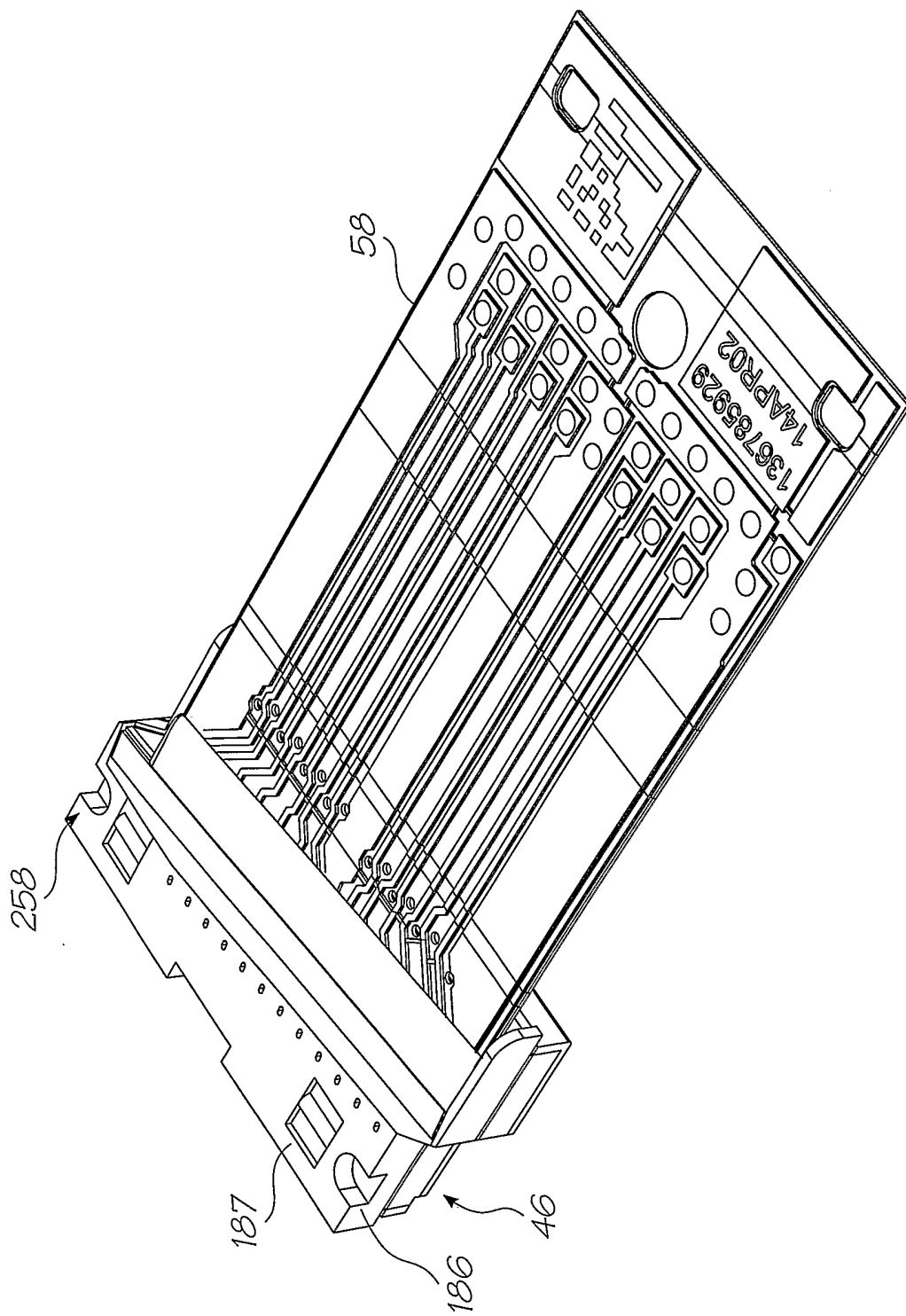

FIG. 14

INTERNATIONAL SEARCH REPORT

International application No.

PCT/AU02/00764

A. CLASSIFICATION OF SUBJECT MATTER		
Int. Cl. ⁷ : B41J 2/175, B81B 7/02, 7/04		
According to International Patent Classification (IPC) or to both national classification and IPC		
B. FIELDS SEARCHED		
Minimum documentation searched (classification system followed by classification symbols)		
IPC PLEASE SEE THE ELECTRONIC DATABASE CONSULTED BELOW		
Documentation searched other than minimum documentation to the extent that such documents are included in the fields searched		
Electronic data base consulted during the international search (name of data base and, where practicable, search terms used)		
DWPI: IPC B41J 2/-, B81B, B81C, B83B and key words {(drop per second); (print zone); (billion); (page width)}		
C. DOCUMENTS CONSIDERED TO BE RELEVANT		
Category*	Citation of document, with indication, where appropriate, of the relevant passages	Relevant to claim No.
A	EP 0837425 A (HEWLETT-PACKARD COMPANY) 22 April 1998 See entire document	
A	US 6318838 B1 (ANDERSON et al) 20 November 2001 See entire document	
A	US 4999644 A (KATERBERG et al) 12 March 1991 See entire document	
<input type="checkbox"/> Further documents are listed in the continuation of Box C <input checked="" type="checkbox"/> See patent family annex		
<p>* Special categories of cited documents:</p> <p>"A" document defining the general state of the art which is not considered to be of particular relevance</p> <p>"E" earlier application or patent but published on or after the international filing date</p> <p>"L" document which may throw doubts on priority claim(s) or which is cited to establish the publication date of another citation or other special reason (as specified)</p> <p>"O" document referring to an oral disclosure, use, exhibition or other means</p> <p>"P" document published prior to the international filing date but later than the priority date claimed</p> <p>"T" later document published after the international filing date or priority date and not in conflict with the application but cited to understand the principle or theory underlying the invention</p> <p>"X" document of particular relevance; the claimed invention cannot be considered novel or cannot be considered to involve an inventive step when the document is taken alone</p> <p>"Y" document of particular relevance; the claimed invention cannot be considered to involve an inventive step when the document is combined with one or more other such documents, such combination being obvious to a person skilled in the art</p> <p>"&" document member of the same patent family</p>		
Date of the actual completion of the international search 27 June 2002	Date of mailing of the international search report 11 JUL 2002	
Name and mailing address of the ISA/AU AUSTRALIAN PATENT OFFICE PO BOX 200, WODEN ACT 2606, AUSTRALIA E-mail address: pct@ipaustrialia.gov.au Facsimile No. (02) 6285 3929	Authorized officer DALE SIVER Telephone No : (02) 6283 2196	

INTERNATIONAL SEARCH REPORT

Information on patent family members

International application No.

PCT/AU02/00764

This Annex lists the known "A" publication level patent family members relating to the patent documents cited in the above-mentioned international search report. The Australian Patent Office is in no way liable for these particulars which are merely given for the purpose of information.

Patent Document Cited in Search Report		Patent Family Member			
EP	0837425	JP	10157171		
US	6318838	NONE			
US	4999644	EP	458943	WO	91/08901
END OF ANNEX					