



(86) Date de dépôt PCT/PCT Filing Date: 2011/04/18
 (87) Date publication PCT/PCT Publication Date: 2011/10/27
 (85) Entrée phase nationale/National Entry: 2012/10/05
 (86) N° demande PCT/PCT Application No.: IB 2011/000854
 (87) N° publication PCT/PCT Publication No.: 2011/132056
 (30) Priorité/Priority: 2010/04/19 (IT MI2010A000660)

(51) Cl.Int./Int.Cl. *C10G 1/00* (2006.01),
C10G 9/00 (2006.01), *C10G 9/40* (2006.01),
E21B 43/24 (2006.01), *F24J 2/00* (2006.01)
 (71) Demandeur/Applicant:
 ENI S.P.A., IT
 (72) Inventeurs/Inventors:
 BORTOLO, ROSSELLA, IT;
 RICCO', MORENO, IT
 (74) Agent: ROBIC

(54) Titre : PROCÉDE PERMETTANT DE REDUIRE LA VISCOSITE DE PETROLES BRUTS LOURDS
 (54) Title: PROCESS FOR REDUCING THE VISCOSITY OF HEAVY CRUDE OILS

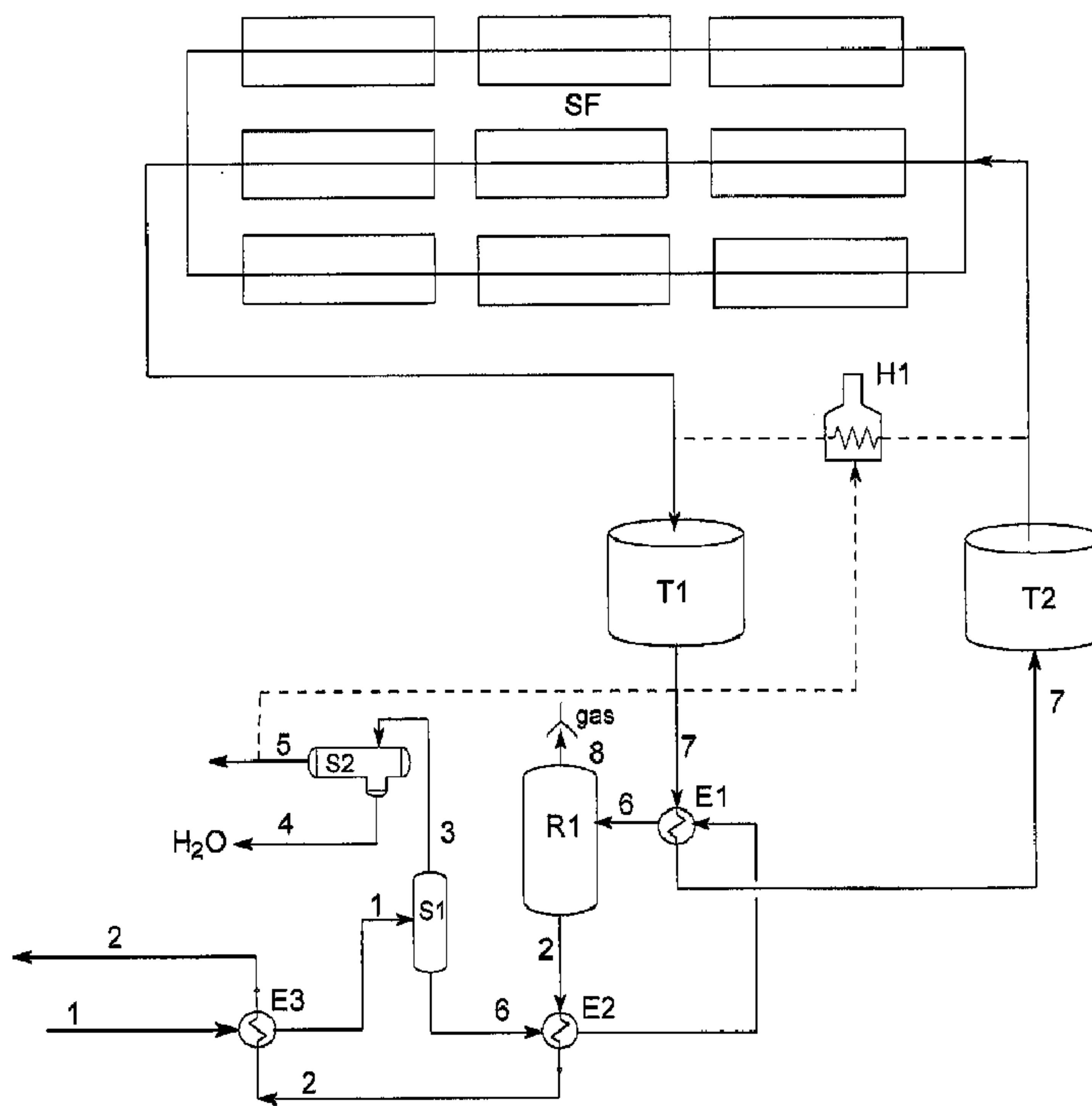

Fig.1

(57) Abrégé/Abstract:

Process for reducing the viscosity of heavy crude oils in situ, directly at the well head or oil centre, through "mild visbreaking", characterized in that the energy necessary for said visbreaking is obtained by means of a solar concentration plant, before being

(57) **Abrégé(suite)/Abstract(continued):**

subjected to said visbreaking, said heavy crude oils being pre-heated by at least one thermal exchange with the obtained crude oils having a reduced viscosity.

(12) INTERNATIONAL APPLICATION PUBLISHED UNDER THE PATENT COOPERATION TREATY (PCT)

(19) World Intellectual Property Organization
International Bureau(43) International Publication Date
27 October 2011 (27.10.2011)(10) International Publication Number
WO 2011/132056 A3

(51) International Patent Classification:

C10G 1/00 (2006.01) E21B 43/24 (2006.01)
C10G 9/00 (2006.01) F24J 2/00 (2006.01)
C10G 9/40 (2006.01)

(21) International Application Number:

PCT/IB2011/000854

(22) International Filing Date:

18 April 2011 (18.04.2011)

(25) Filing Language:

Italian

(26) Publication Language:

English

(30) Priority Data:

MI2010A000660 19 April 2010 (19.04.2010) IT

(71) Applicant (for all designated States except US): ENI S.P.A. [IT/IT]; Piazzale E. Mattei, 1, I-00144 Rome (IT).

(72) Inventors; and

(75) Inventors/Applicants (for US only): BORTOLO, Rossella [IT/IT]; Via Gorizia, 29, I-28100 Novara (IT). RICCO', Moreno [IT/IT]; Via San Bernardo, 11, I-20051 Limbiate (MB) (IT).

(74) Agents: COLETTI, Raimondo et al.; Barzano' & Zanardo Milano S.p.A., Via Borgonuovo 10, 20121 Milano (IT).

(81) Designated States (unless otherwise indicated, for every kind of national protection available): AE, AG, AL, AM, AO, AT, AU, AZ, BA, BB, BG, BH, BR, BW, BY, BZ, CA, CH, CL, CN, CO, CR, CU, CZ, DE, DK, DM, DO, DZ, EC, EE, EG, ES, FI, GB, GD, GE, GH, GM, GT, HN, HR, HU, ID, IL, IN, IS, JP, KE, KG, KM, KN, KP, KR, KZ, LA, LC, LK, LR, LS, LT, LU, LY, MA, MD, ME, MG, MK, MN, MW, MX, MY, MZ, NA, NG, NI, NO, NZ, OM, PE, PG, PH, PL, PT, RO, RS, RU, SC, SD, SE, SG, SK, SL, SM, ST, SV, SY, TH, TJ, TM, TN, TR, TT, TZ, UA, UG, US, UZ, VC, VN, ZA, ZM, ZW.

(84) Designated States (unless otherwise indicated, for every kind of regional protection available): ARIPO (BW, GH, GM, KE, LR, LS, MW, MZ, NA, SD, SL, SZ, TZ, UG, ZM, ZW), Eurasian (AM, AZ, BY, KG, KZ, MD, RU, TJ, TM), European (AL, AT, BE, BG, CH, CY, CZ, DE, DK, EE, ES, FI, FR, GB, GR, HR, HU, IE, IS, IT, LT, LU, LV, MC, MK, MT, NL, NO, PL, PT, RO, RS, SE, SI, SK,

[Continued on next page]

(54) Title: PROCESS FOR REDUCING THE VISCOSITY OF HEAVY CRUDE OILS

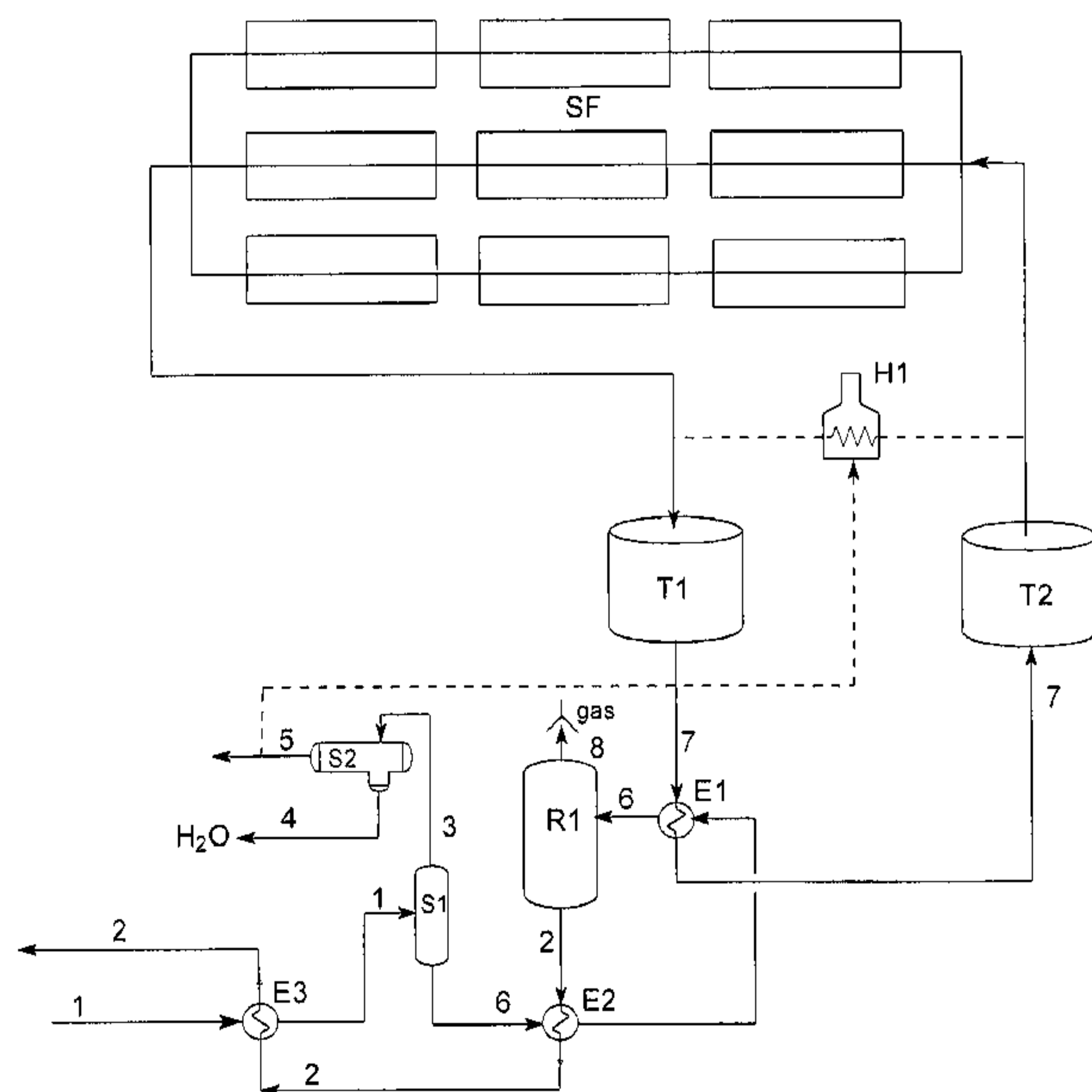

Fig.1

(57) Abstract: Process for reducing the viscosity of heavy crude oils in situ, directly at the well head or oil centre, through "mild visbreaking", characterized in that the energy necessary for said visbreaking is obtained by means of a solar concentration plant, before being subjected to said visbreaking, said heavy crude oils being pre-heated by at least one thermal exchange with the obtained crude oils having a reduced viscosity.

WO 2011/132056 A3



SM, TR), OAPI (BF, BJ, CF, CG, CI, CM, GA, GN, GQ,
GW, ML, MR, NE, SN, TD, TG).

— *before the expiration of the time limit for amending the
claims and to be republished in the event of receipt of
amendments (Rule 48.2(h))*

Published:

— *with international search report (Art. 21(3))*

(88) Date of publication of the international search report:

18 May 2012

PROCESS FOR REDUCING THE VISCOSITY OF HEAVY CRUDE OILS

The present patent application relates to a process for reducing the viscosity of heavy crude oils by means of a thermal treatment, known as "mild visbreaking",
5 effected directly at the well head or oil centre.

A decrease in the availability of high-quality crude oils, a problem which will become increasingly more important in the future, has led to a greater interest in exploiting reservoirs of so-called "diffi-
10 cult" hydrocarbons: among these heavy crude oils, bitumens and oil sands can be mentioned.

Heavy crude oils are characterized by a high viscosity, a factor which greatly limits their mobility and transportation in pipelines. Many heavy crude oils
15 in fact can be produced spontaneously or with the assistance of pumps as their reservoir temperature is sufficiently high to guarantee a low viscosity but once they have reached the surface, the temperature of the oil is lowered and the viscosity consequently increases
20 making their transportation difficult in the pipelines.

The viscosity of oil is a limiting factor for an efficient transportation in the pipelines: with an increase in the viscosity, the relative transportation costs also increase, as a result, for example, of the
25 higher energy consumption due to the pumping systems.

Among the various methods known in the art for improving the transportability of heavy oils, the following can be mentioned in particular:

- heating: the viscosity decreases with the temperature.

Insulated pipelines and periodic heating stations are necessary and consequently there are high energy costs obtaining a non-permanent reduction in the viscosity. Furthermore, the method cannot be effected
5 for long sections or for underwater pipelines.

- dilution: addition of 10 to 50% of diluent (light hydrocarbon fraction).

Mixing and separation stations (effected by distillation, and therefore energetically unfavourable) are
10 necessary, with the generation at times of instability in the oil and a consequent precipitation of asphaltenes. In addition to also requiring a return pipeline for the diluent (from the well separation column), the addition of the diluent itself reduces
15 the transportation capacity of the pipelines as the total volume of the fluid increases.

- formation of oil-in-water emulsions: the viscosity is reduced as an emulsion has a viscosity close to that of the continuous phase, and as water is less viscous
20 (in these particular cases) than the heavy oil, the viscosity of the emulsion is lower than that of the oil as such.

The problems are: difficulty in selecting the surfactants to be used, the necessity of obtaining a sufficiently stable emulsion which can then be easily broken at the end of the transportation, quantity of water to be added that can even be very high, with a
25 consequent reduction in the transportation capacity of the pipelines due to the increase in volume,

breakage of the emulsion at the end of the transportation, recovery and recycling of the water.

- addition of suitable additives, called drag reducers or the addition of surfactants.

5 These are often ineffective for very heavy oils, they are costly and at times a significant quantity is required.

- Thermal methods for upgrading at the well head: partial crackings.

10 As they require a considerable amount of energy, if effected with traditional technologies and thermal sources, they require a high consumption of fossil fuel, with a consequent production of CO₂.

15 Patent US-5,110,447 falls within the latter thermal methods, in which a mild visbreaking step is used for purifying and reducing the viscosity of the heavy oils.

A process has now been found which, thanks to a thermal treatment directly at the well head or oil centre, called "mild visbreaking", gives rise to a partial cracking of the heavy components, through the energy obtained by means of a solar concentration plant, generating a significant and permanent reduction in the viscosity of the oil, thus enabling it to be easily
25 transported in the pipelines.

The process, object of the present invention, for reducing the viscosity of heavy crude oils, in situ, directly at the well head or oil centre, comprises subjecting said heavy crude oils to mild visbreaking and

is characterized in that the energy necessary for said mild visbreaking is obtained by means of a solar concentration plant.

Before being subjected to mild visbreaking, the heavy crude oils can be preheated by means of one or more thermal exchanges with the crude oils having a reduced viscosity obtained by means of said mild visbreaking, thus reducing the energy demand on the part of the solar plant.

Said exchanges can be effected at different temperature levels, always lower however than the visbreaking reaction temperature, so as to cause the demixing of the liquid aqueous phase, without generating a vapour phase, or so as to cause the generation and removal of a gaseous phase. This second procedure can preferably be effected in what is known as a flash unit.

The preferred conditions for these pre-heatings envisage a temperature ranging from 100°C to 180°C, more preferably from 100°C to 120°C when the demixing of the water in liquid phase is to be generated, and from 150°C to 180°C when a separation by means of flash is to be effected.

The gaseous phase formed by means of flash can be subjected to condensation thus separating the water and condensable vapours substantially consisting of light hydrocarbons. Said light hydrocarbons separated in the condensation step can be used as liquid fuel for providing further thermal energy, in a suitable solar

range integration boiler.

After the thermal treatment, the heavy crude oil is sent to the visbreaking reactor. As a result of the reaction, a liquid phase is generated, consisting of the crude oil having a reduced viscosity, and a vapour phase. Said vapour phase can consist of condensable light hydrocarbons, water and uncondensable reaction gases. Said vapour phase can be subjected to the following operations:

- 10 • the vapour phase is condensed separating water and light hydrocarbons from the incondensable gases and the light hydrocarbons, separated from the water, can be at least partly used as liquid fuel, in a specific integration boiler.
- 15 • the vapour phase is condensed separating the light hydrocarbons from the incondensable gases and at least partly used as liquid fuel in a specific integration boiler.
- the vapour phase is sent to a combustion torch.

20 The process claimed is self-sufficient from an energy point of view, envisaging a solar field having dimensions which are such as to guarantee the whole energy requirement, and also integrating the solar energy with the energy obtained by burning part of the light hydrocarbons obtained from the same process as support-
25 fuel. This process is particularly suitable for exploiting medium-small fields, localized in remote sites, not completely equipped with all utilities.

The process claimed, moreover, is conceived for be-

ing effected as close as possible to the oil extraction point (well head or oil centre close to the production wells).

Mild visbreaking is a partial pyrolysis process of the heavy components of a petroleum, which leads to a cracking of hydrocarbon chains and a consequent reduction in the average molecular weights. The product obtained is an oil having a lower viscosity, with the contemporaneous production of a certain percentage of light hydrocarbon products (gaseous or liquid). Unlike the classical visbreaking process which is effected in refineries on heavy vacuum distillation residues, aimed at effectively upgrading the residues and maximizing the production of light fractions, operating at temperatures ranging from 425 to 530°C depending on the type of process and severity of the treatment, mild visbreaking is effected under much blander conditions, with temperatures lower than or equal to 400°C. The objective of the process is not in fact the actual upgrading of the oil but reducing its viscosity to favour its transportation in the pipelines. The mild visbreaking step used in the process according to the invention is consequently simpler from a plant-engineering point of view, with respect to traditional visbreaking and does not involve any fractionation of the oil produced after the reaction.

The sole purpose of the mild visbreaking step used in the process according to the invention is to reduce the viscosity of the crude oil so that it reaches the

transportability standards in the pipelines, but it does not envisage separation of the products, except for possibly the light fractions which are spontaneously developed in the process.

5 The visbreaking reaction in particular takes place in a reactor heated by solar fluid and the reaction conditions preferably envisage:

- a temperature ranging from 350°C to 400°C, more preferably from 370°C to 390°C;
- 10 • a pressure ranging from 5 to 50 atm, more preferably from 10 to 20 atm;
- a residence time ranging from 20 min to 2.5 hours: in particular these times are longer for lower temperatures and shorter for higher temperatures.

15 The possibility of varying the reaction conditions allows greater freedom in selecting the solar fluid: if the reaction is carried out at a temperature higher than 380°C, in fact, the fluid to be used as heating fluid for the reactor is preferably a mixture of molten
20 salts, which is heated by the solar field up to temperatures of 440-450°C. If the reaction temperature is lower than 380°C, it is possible to use diathermic oil as heating fluid, which is heated in the solar field up to 385-390°C.

25 It is known in fact that diathermic oil has a poor stability for temperatures higher than 400°C, but, on the other hand, if it is possible to operate at lower temperatures, it has economical advantages for the management of the solar field (simpler equipment and less

costly materials). Salt, on the contrary, can reach higher temperatures (depending on the mixture of salts selected, up to 550-600°C) and has advantages in terms of storage, but it requires special equipment and a more complex plant management. The selection of the optimum reaction conditions will be therefore a balance between the various factors.

The solar plant converts solar radiation into high-temperature heat using mirrors which can have various configurations. In the focus of the mirrors, there is a receiver containing a fluid, called heat transfer fluid, which is heated and is then capable of transferring the heat, through a specific circuit, to the reactor in which the reaction on the heavy oils takes place. For the concentration of the solar energy, it is possible to use any of the currently known technologies, or innovative configurations specifically produced for the purpose. Among the known technologies, the following can be considered:

- Systems with linear parabolic concentrators (Parabolic Trough Systems)
- Systems with linear concentrators of the Fresnel type
- Tower systems with a central receiver (Central Receiver Systems - CRS)
- Parabolic disk systems.

For the process considered, a system with a linear parabolic concentrator (Parabolic Trough System) is preferably used, without, however, excluding, a priori,

other solutions.

In linear parabolic concentrators, the direct solar radiation is concentrated through the linear parabolic reflecting systems on a straight receiving tube situated in the focus of the parabolic dishes. This energy is used for heating a heat transfer fluid which circulates inside the receiving tube.

The heat transfer fluids which can be used must be characterized by a sufficient thermal stability and can be synthetic oils, mixtures of molten salts or gas.

The diathermic oils used as heat transfer fluids can be selected from commercial mixtures either known or specifically prepared, provided they are suitable for high-temperature applications. Non-limiting examples are biphenyl-biphenylether eutectic mixtures, stable up to 450°C (such as the commercial fluids Therminol VP1 of Solutia or Dowtherm A of DOW Chemical), mixtures of polysiloxanes, stable up to 400°C (such as the commercial fluid Syltherm 800 of Dow Corning Corp.) or mixtures of alkyl-polyphenyls, stable up to 400°C (such as the commercial fluid Therminol 75 of Solutia).

The molten salts used as heat transfer fluids and/or as thermal storage fluids can be selected from the various commercial mixtures either known in literature or specifically prepared.

Non-limiting examples of mixtures which can be used are binary mixtures of NaNO_3 and KNO_3 (for example so-called "solar salt" composed of NaNO_3 and KNO_3 in a

ratio of about 60:40 wt with a melting point of 225°C), binary mixtures of NaNO_3 and NaNO_2 (such as, for example the eutectic mixture NaNO_3 - NaNO_2 in a ratio of 45:55 wt with a melting point of 225°C), ternary mix-
5 tures of KNO_3 , NaNO_3 , LiNO_3 (such as the eutectic mixture KNO_3 52% wt, NaNO_3 18% wt, LiNO_3 30% wt with a melting point of 120°C), ternary mixtures of KNO_3 , NaNO_3 , $\text{Ca}(\text{NO}_3)_2$ (such as the so-called HITEC XL consisting of KNO_3 45% wt, NaNO_3 7% wt, $\text{Ca}(\text{NO}_3)_2$
10 48% wt with a melting point of 136°C), ternary mixtures of KNO_3 , NaNO_3 , NaNO_2 (such as the so-called HITEC consisting of KNO_3 53% wt, NaNO_3 7% wt, NaNO_2 40% wt a melting point of 142°C).

The gases can be permanent gases such as nitrogen,
15 air or carbon dioxide, or vapours, such as water vapour, both used at atmospheric pressure or higher. They can also be in a supercritical state, such as for example supercritical CO_2 .

In the present patent, the heat transfer fluids are
20 preferably mixtures of molten salts or synthetic oils.

The linear parabolic collectors can be selected from commercial devices, such as, for example, EURO-TROUGH collectors, LUZ collectors or SOLARGENIX collectors.

25 The reflecting material can be vitreous (mirrors having various thicknesses), metallic (aluminium) or plastic (reflecting thin films) material.

The receiver tubes consist of a steel tube on which a layer of spectrally selective material is deposited,

characterized by a high absorbance of direct solar radiation and a low infrared heat emissivity. Said receiver tubes can be selected from those available on the market (for example Schott, Angelantoni, Solel
5 tubes) or they can be specifically constructed.

Some embodiments of the present invention are now provided, in relation to the heat transfer fluid selected, with the help of the schemes of figures 1-4 enclosed, which, however, should not be considered as
10 limiting the scope of the invention itself.

In principle, however there are no exclusions for the application of any of the schemes regardless of the heat transfer fluid selected.

In Figure 1, a process according to the present invention is schematized, which is particularly suitable
15 when the heat transfer fluid is molten salt.

The heavy crude oil (1) is preheated in a first exchanger (E3), by thermal exchange with the outgoing product (crude oil with a reduced viscosity) (2), then
20 sent to a separation section (S1) by means of flash, separating a gaseous stream (3) which is condensed in a partial condenser (S2) in which the light hydrocarbons (5) and condensed water (4) are separated from the residual crude oil (6).

25 Said residual crude oil (6) is sent to a second exchanger (E2), where it is further heated to a higher thermal level by the outgoing product (2), and to a third exchanger (E1) in which it is brought to the reaction temperature by the solar fluid (7), before being

fed to the reactor (R1) where the mild visbreaking takes place. The outgoing product (2), the crude oil with a reduced viscosity, leaving the reactor (R1), is sent to the pipelines, after yielding the heat in the exchangers (E2) and (E3).

The gas (8) leaving the reactor (R1) is burnt in a torch.

The light hydrocarbons (5) are a hydrocarbon cut which can be upgraded to product and/or also suitable for being possibly used as fuel for feeding a supplementary burner (H1), which is used for heating the solar fluid in the moments when there is no insolation.

The solar fluid is heated to a temperature higher than the reaction temperature thanks to the mirrors of the solar field (SF). It is collected in a tank (T1) defined as "hot" having such dimensions as to guarantee a constant feeding to the reactor. When leaving the exchanger of the reactor, the solar fluid which has yielded heat, passes into a tank (T2) defined as "cold" from which it is fed to the solar field (or to the integration boiler) to be re-heated.

Figure 2 schematizes another process according to the present invention, which is also particularly suitable when the heat transfer fluid is molten salt.

The heavy crude oil (1) is preheated in a first exchanger (E3), by thermal exchange with the outgoing product (heavy crude oil with a reduced viscosity) (2), then possibly sent to a separator (S2), to separate the water (4) from the residual crude oil (6).

Said residual crude oil (6), possibly separated from the water, is sent to a second exchanger (E2), where it is further heated to a higher thermal level by the outgoing product (2), and to a third exchanger (E1) in which it is brought to the reaction temperature by the solar fluid (7), before being fed to the reactor (R1) where the mild visbreaking takes place. The outgoing product (2), the crude oil with a reduced viscosity, leaving the reactor (R1), is sent to the pipelines, after yielding the heat in the exchangers (E2) and (E3).

The gas (8), containing light hydrocarbons, leaving the reactor (R1) can either be burnt directly in a torch, or conveniently subjected to condensation in the condenser (C) obtaining a liquid hydrocarbon cut (5), which can be upgraded to product (5) and/or also suitable for being possibly used as fuel for feeding a supplementary burner (H1), which is used for heating the solar fluid in the moments when there is no insolation. A further part of uncondensed gases will obviously leave the condenser, which can be burnt directly in a torch.

The thermal cycle of the solar fluid is analogous to that described in Figure 1.

Figure 3 schematizes a process according to the present invention which is particularly suitable when the heat transfer fluid is synthetic oil.

With respect to the scheme of Figure 1, only the part relating to the solar fluid described below var-

ies.

As the solar energy is not constant for all the hours of the day, and in some hours it is even excessive with respect to the energy requirement of the process, two storage tanks with molten salts are inserted in the circuit (in this case the salts are not heat transfer fluids but materials for thermal storage). In the moments in which there is an energy surplus, the flow of diathermic oil (7) is divided between two different circuits: that which leads directly to the exchanger (E1) of the reactor and that which leads to the exchanger (E4) of the tanks for the heating of the salts. In the heat accumulation phase, the salts (9) pass from the "cold" tank (T1) to the "hot" tank (T2) through the exchanger (E4). The salt tanks serve as thermal accumulation for partly satisfying the energy demand in the moments in which there is no sun, and therefore reducing the use of the integration boiler: in this case, the flow of the salts is inverted, passing from the hot tank to the cold tank, yielding heat to the diathermic oil in the exchanger E4. The oil is thus preheated by the flow of salts and, even if it does not reach the thermal levels necessary for the reaction (which are reached with the use of the integration boiler), it makes the consumption of fuel due to the boiler much lower.

Figure 4 schematizes another process according to the present invention which is also suitable when the heat transfer fluid is synthetic oil.

With respect to the scheme of Figure 2, only the part relating to the solar fluid varies, which is equal to that described in Figure 3.

EXAMPLE 1

5 (heavy crude oil at 2% of water, separation of light products at 160°C and treatment at 380°C)

The permanent reduction treatment of the viscosity was tested experimentally on a 500 ml autoclave, using a heavy crude oil coming from reservoirs localized in
10 Southern Italy, called G1. The crude oil G1 has a dynamic viscosity, measured at 40°C, equal to 1,710 mPa.s corresponding to a kinematic viscosity of 1,729 mm²/s and has an API Gravity @ 60/60°F (according to the method ASTM 287) corresponding to 11.6 degrees. The
15 initial composition of the crude oil G1 is indicated in Table 1.

200 g of G1, is subjected to flash distillation at 160°C to obtain the separation of water and light hydrocarbons.

20 After condensation of the vapour phase, water is obtained together with a liquid hydrocarbon phase having the composition indicated in Table 2. Upon elemental analysis, this fraction proves to be free of compounds containing S or N.

25 The residual liquid phase in the boiler, called "G1-residue 160+", has a viscosity of 5,560 mPa.s. Said oil G1-residue 160+ is charged into a 500 ml autoclave and brought to a temperature of 380°C, with a residence time at this temperature equal to 1 h.

At the end of the reaction, the autoclave is rapidly cooled to room temperature. The product obtained is an oil having a dynamic viscosity equal to 150 mPa.s, corresponding to a kinematic viscosity equal to 155 mm²/s, both measured at 40°C.

The formation of coke or tar was not observed.

The viscosity values obtained from the treatment were maintained even 60 days after the test.

SARA (Saturated compounds, Aromatics, Resins, Asphaltenes) analysis, effected by means of the TLC/FID Iatroscan method, revealed an increase in the aromatic fraction in the crude oil treated. The data relating to the SARA analysis are indicated in Table 3.

15

Table 1: composition of crude oil G1

G1: composition of initial crude oil	
Water	2.22% wt
Gas+LPG	0.205% wt
liquids bp<160°C	4.60% wt
cut160<bp<530°C	39.90% wt
Heavy cut >530°C	53.07% wt

Table 2: light liquids from flash 160

	%wt
C3	0.073
C4	1.532
C5	6.02
C6+ benzene	15.958
C7+toluene	24.55

C8+xylene	25.32
C9	14.978
C10+benzC3	8.313
C11+benzC4	2.773
C12+naphthalene	0.243
C13	0.198
C14	0.029
C15-C20	0.015

5 Table 3: analysis of the Saturated compounds, Aromatics, Resins, Asphaltenes on the crude oil G1 before and after treatment (method SARA TLC/FID Iatroscan)

TEST	viscosity mm²/s	Saturated compounds %wt	Aromatics %wt	Resins %wt	Asphaltenes %wt
G1-residue 160+	4163	5.0	26.0	37.4	31.5
G1-example 1	155	5.5	48.5	16.4	29.6
G1-example 2	190	4.9	51.6	17.1	26.4

EXAMPLE 2

10 The crude oil G1 is treated as described in Example 1, but subjected to treatment in an autoclave at a temperature of 385°C with a residence time of 30 minutes. An oil is obtained, with a dynamic viscosity equal to

183 mPa.s, corresponding to a kinematic viscosity equal to 190 mm²/s, both measured at 40°C.

The formation of coke or tar is not observed. The SARA analysis is indicated in Table 3.

5 EXAMPLE 3

The crude oil G1 is treated as described in Example 1, but subjected to treatment in an autoclave at a temperature of 370°C with a residence time of 1.5 h. An oil is obtained, with a dynamic viscosity equal to 195
10 mPa.s, corresponding to a kinematic viscosity equal to 209 mm²/s, both measured at 40°C.

The formation of coke or tar is not observed.

EXAMPLE 4

(heavy crude oil at 2% of water, sent directly to
15 treatment at 380°C)

200 g of G1 are charged directly into a 500 ml autoclave, equipped with a relief valve at 10 bar, without thermal pre-treatment to separate water and light hydrocarbons, and brought to a temperature of
20 380°C. The outlet of the relief valve is connected to a condenser and a collection tank, in order to condense and collect the reaction vapours.

After a residence time of 1 hour, the autoclave is rapidly cooled.

25 The oil obtained has a dynamic viscosity, measured at 40°C, equal to 120 mPa.s, corresponding to a kinematic viscosity equal to 125 mm²/s. The formation of coke or tar was not observed. Water and liquid light hydrocarbons are recovered in the collection tank.

EXAMPLE 5

(heavy crude oil at 21% of water, sent directly to treatment at 380°C)

A heavy crude oil, coming from reservoirs in Southern Italy containing 21% by weight of emulsified water not spontaneously separable, has dynamic viscosity, measured at 40°C, equal to 13,850 mPa.s. This crude oil is called G2.

200 g of G2 are charged directly into a 500 ml autoclave, equipped with a relief valve at 10 bar, and brought to a temperature of 380°C. The outlet of the relief valve is connected to a condenser and a collection tank, in order to condense and collect the reaction vapours.

After a residence time of 1 hour, the autoclave is rapidly cooled.

The oil obtained has a dynamic viscosity, measured at 40°C, equal to 241 mPa.s, corresponding to a kinematic viscosity equal to 246 mm²/s.

The formation of coke or tar was not observed. Water and liquid light hydrocarbons are recovered in the collection tank.

(Simulations of the process were effected on a scale of 5,000 bbl/day developing a model with a proprietary simulator (CheOpe -Chemical Operations) on the basis of the experimental data obtained by the laboratory tests. The program SAM - Solar Advisor Model prepared by DOE/NREL/MRI was partly used for the dimensioning and optimization of the solar field).

EXAMPLE 6

(oil with a low water content (G1), process comprising a flash section at 160°C + reaction at 380°C with $\tau=1\text{h}$, solar fluid: molten salts)

5 Effected according to the scheme of figure 1.

A flow-rate at the inlet equal to 5,000 bbl/day (32,750 kg/h) of a crude oil with a low water content (2%) such as the crude oil G1, is envisaged.

The crude oil entering the plant has a temperature
10 of 70°C and is sent to the flash section S1 into which the exchanger E3 conveys the crude oil at 160°C and where the water and light products are vaporized. The water and light products are cooled thanks to an air cooler and sent to a separator S2, from which the water
15 passes to water treatment (flow 4) whereas the condensed light products are recovered (flow 5). After the treatment at 160°C, the crude oil passes to the exchanger E2 for a preheating to 339°C and finally to the reaction section R1 where the exchanger E1 completes
20 the heating to the reaction temperature. The residence time in the reactor is 1 h. The exchanger E1 is fed with the molten salts coming from the solar field (flow 7), the exchangers E2 and E3 are the thermal recoveries fed by the upgraded crude oil leaving the reactor (flow
25 2). The molten salts coming from the solar field have a temperature of 410°C and re-enter the solar field at a temperature of 362.6°C.

In order to guarantee service continuity, the heat transfer fluid of the solar field is stored in two

tanks T1 and T2 ("hot" and "cold") capable of maintaining the temperature constant for at least 6 h. An integration boiler H1, which is capable of integrating or substituting the solar heating, if necessary, is also
5 envisaged.

In this process, 31,576 Kg/h of upgraded oil are produced, of which 1,376 Kg/h of liquid light hydrocarbons having a composition assimilable to a diesel fuel. Of these, a part can be used for feeding the integration boiler H1 of the solar field. The reaction and
10 flash gases, on the other hand, are sent to a torch, for a total of 461.2 kg/h. The water sent for treatment is 712.8 kg/h.

The solar fluids which feed the exchanger E1 must
15 supply 1,474 Mcal/h, corresponding to a yearly requirement of 15,766 MWh. For a localization in an area of Southern Italy, a solar plant is envisaged, comprising a thermal storage dimensioned for 6 h, which, with a reflecting surface of 7,525 m², is capable of supplying
20 4,029 MWh of energy: this value corresponds to 25.6% of the total demand, whereas the remaining 11,737 MWh must be supplied by feeding the integration boiler with 115 kg/h of diesel fuel, obtained from the same process.

The reflecting surface indicated can be obtained by
25 imagining a field of 16 collectors which occupy an area of about 26,000 m².

EXAMPLE 7

(oil with a low water content (G1), reaction directly on the crude oil as such at 380°C and $\tau=1h$, solar

fluid: molten salts)

Effectuated according to the scheme of figure 2.

A flow-rate at the inlet equal to 5,000 bbl/day
(32,750 kg/h) of an oil with a low water content (2%)
5 such as G1, is envisaged.

The crude oil entering the plant at a temperature
of 70°C, is sent to the exchanger E2, fed by the up-
graded crude oil leaving the reactor (flow 2), for a
preheating to 329.7°C. The crude oil is subsequently
10 sent to the reactor R1 where the reaction temperature
of 380°C is maintained thanks to the exchanger E1, fed
by the fluid coming from the solar field (flow 7). A
recycling to the reactor is envisaged in order to regu-
late the residence time to 1 h. The molten salts used
15 as heat transfer fluid in the exchanger E1 leave the
solar field at a temperature of 400°C and re-enter it
at a temperature of 376.5°C. The heat transfer fluid of
the solar field is stored in two tanks T1 and T2 ("hot"
and "cold") capable of maintaining the temperature con-
20 stant for at least 6 h. An integration boiler H1, which
is capable of integrating or substituting the solar
heating, if necessary, is also envisaged.

The upgraded crude oil leaving the reactor (flow 2)
is sent to the exchanger E2 for thermal recovery, be-
25 fore reaching the pipelines. In addition to the up-
graded crude oil (28,748 kg/h), a vapour phase (flow
8) composed of water (688 kg/h), light hydrocarbons
(2,940 kg/h) and reaction gas (394 kg/h) also leaves
the reactor, which can be separated, after cooling by

means of the condenser C. Also in this case, a part of the light hydrocarbons can be used for feeding the integration boiler H1.

In this case, the solar fluids which feed the exchanger E1 must supply 1,624 Mcal/h, corresponding to a yearly demand of 16,541 MWh. The quantities of energy in question are not significantly different with respect to Example 6: the solar plant necessary is consequently completely analogous to that described for Example 6.

EXAMPLE 8

(oil with a high water content (e.g. G2), process preceded by demixing and water separation at 105°C, reaction at 380°C with $\tau=1h$, solar fluid: molten salts) Effected according to the scheme of figure 2.

A flow-rate at the inlet of the plant equal to 5,000 bbl/day (32,750 kg/h) of a crude oil with a high water content (20%) such as G2, is envisaged.

The crude oil enters the plant at a temperature of 70°C and passes to the separator S2 where the thermal breakage of the emulsions and separation of the water take place. The demixing is effected at a temperature of 105°C and 1.5 atm of pressure, without the formation of vapour phase, envisaging residence times of 1h for the organic phase and 2 h for the aqueous phase. The heat necessary for the demixing is supplied by the exchanger E3 fed by the upgraded crude oil leaving the reactor (flow 2).

The crude oil therefore undergoes further heating

to 355°C by means of the exchanger E2, which is also fed by the upgraded crude oil leaving the reactor, and reaches the reactor R1 where the reaction is carried out at 380°C for 1 h.

5 The heat necessary for reaching the reaction temperature is supplied by the exchanger E1 fed by the molten salts coming from the solar field. The temperature of the salts leaving the solar field is 400°C and 370.2°C when re-entering the solar field (flow 7). The
10 heat transfer fluid of the solar field is stored in two tanks T1 and T2 ("hot" and "cold") capable of maintaining the temperature constant for at least 6 h. An integration boiler H1, which is capable of integrating or substituting the solar heating, if necessary, is also
15 envisaged.

From this process, 25,450 kg/h of upgraded oil, 332 kg/h of reaction gas and 6,968 kg/h of wastewater are produced. Light hydrocarbons which can be used as fuel are not obtained, and consequently an external
20 fuel supply must be adopted for feeding the integration boiler to the solar field.

The solar fluids which feed the exchanger E1 must supply 887.6 Mcal/h, corresponding to a yearly requirement of 9,636 MWh. For a localization in an area
25 of Southern Italy, the solar field (including the storage needed for 6h) will have a reflecting surface of 4,233 m², which can be obtained by imagining a field of 10 collectors, which occupy an area of about 17,000 m². The energy supplied therefore corresponds to 24.4%

of the total demand, i.e. 2,347 MWh of energy. The remaining 7,289 MWh must be supplied by feeding the integration boiler with 71.5 kg/h of fuel.

CLAIMS

1. A process for reducing the viscosity of heavy crude oils in situ, directly at the well head or oil centre, through "mild visbreaking", characterized in that the
5 energy necessary for this visbreaking is obtained by means of a solar concentration plant.
2. The process according to claim 1, wherein, before being subjected to "mild visbreaking", the heavy crude oils are pre-heated by one or more thermal exchanges
10 with crude oils having a reduced viscosity obtained by means of said "mild visbreaking", thus reducing the energy requirement from the solar plant.
3. The process according to claim 2, wherein the thermal exchanges are effected so as to cause the de-mixing
15 of the liquid aqueous phase, without generating a vapour phase, or so as to cause the generation and removal of a gaseous phase.
4. The process according to claim 3, wherein the de-mixing of the aqueous phase and the generation and re-
20 moval of the gaseous phase are preferably effected in a unit called "flash".
5. The process according to claim 4, wherein the gaseous phase formed by flash is subjected to condensation, in this way separating water and condensable vapours
25 substantially consisting of light hydrocarbons.
6. The process according to claim 5, wherein the condensable vapours substantially consisting of light hydrocarbons separated in the condensation step, are used as liquid fuel for providing further thermal energy in

a suitable boiler to integrate the solar field.

7. The process according to claim 1, wherein the gaseous phase generated in the visbreaking reaction, consisting of condensable light hydrocarbons, non-
5 condensable water and reaction gas, is condensed, separating water and light hydrocarbons from the uncondensable gases and light hydrocarbons, separated from the water, can be at least partially used as liquid fuel in a specific integration boiler.

10 8. The process according to claim 1, wherein the gaseous phase generated in the visbreaking reaction, consisting of condensable light hydrocarbons, uncondensable water and reaction gas, is condensed, separating light hydrocarbons from uncondensable gases and at
15 least partially used as liquid fuel in a specific integration boiler.

9. The process according to claim 1, wherein the gaseous phase generated in the visbreaking reaction, consisting of condensable light hydrocarbons, uncondensable water and reaction gas, is sent to the combustion torch.
20

10. The process according to claim 1, wherein the "mild visbreaking" is effected by operating at temperatures lower than or equal to 400°C.

25 11. The process according to claim 10, wherein the "mild visbreaking" is effected by operating at temperatures ranging from 350°C to 400°C.

12. The process according to claim 1, wherein the residence time ranges from 20 minutes to 2.5 hrs.

13. The process according to claim 1, wherein the pressure ranges from 5 to 50 atm.

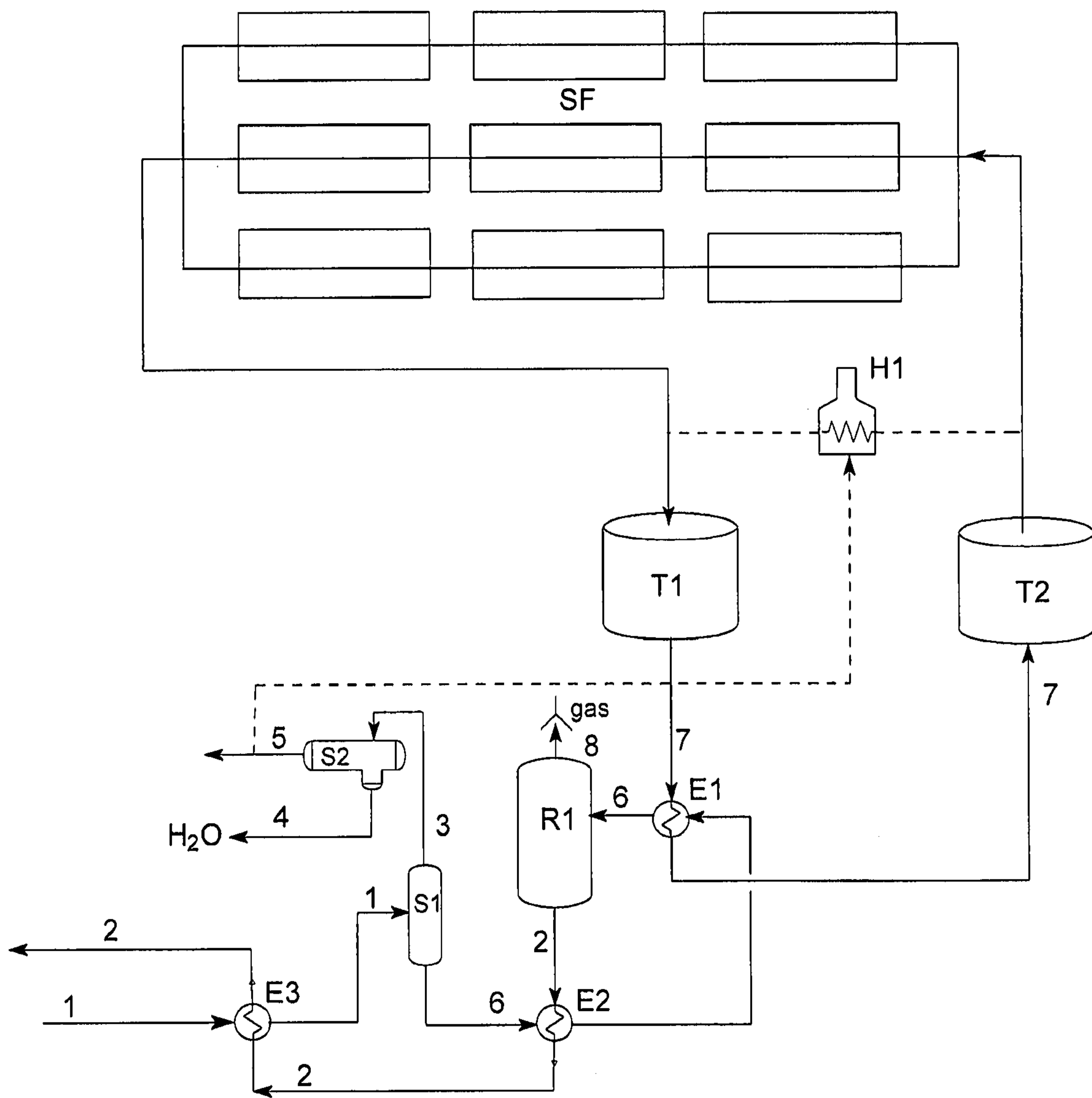

Fig.1

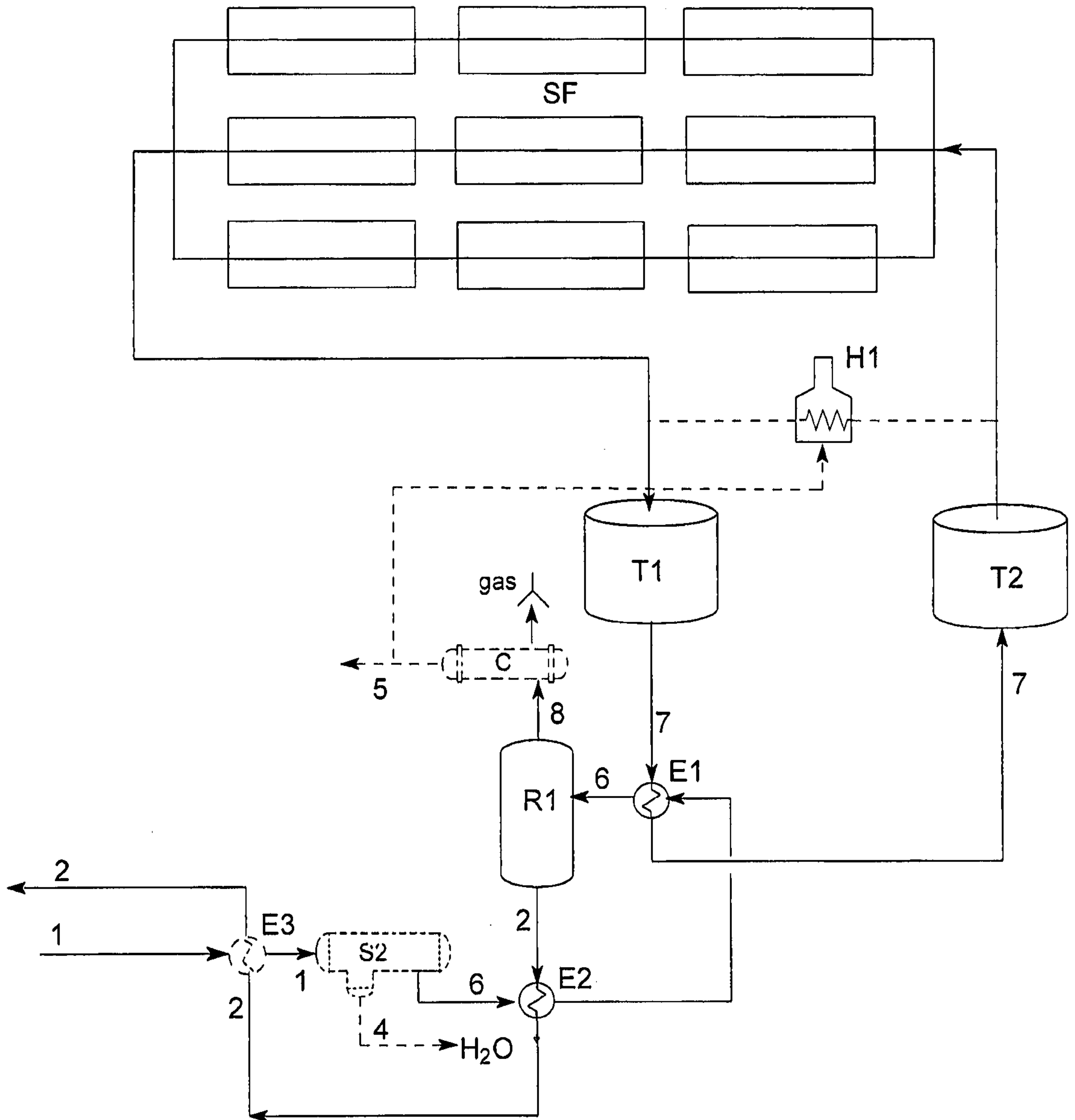

Fig.2

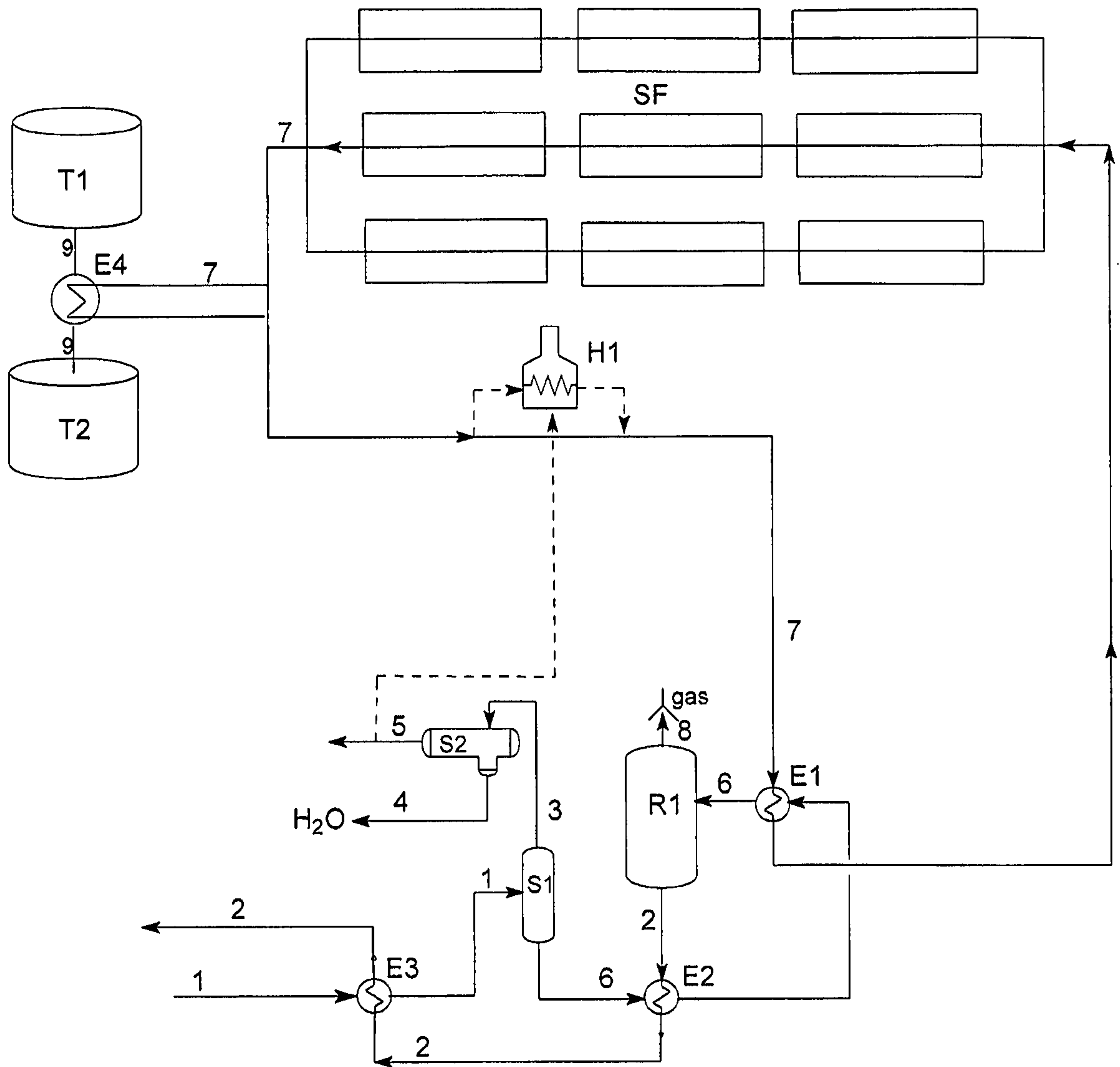

Fig.3

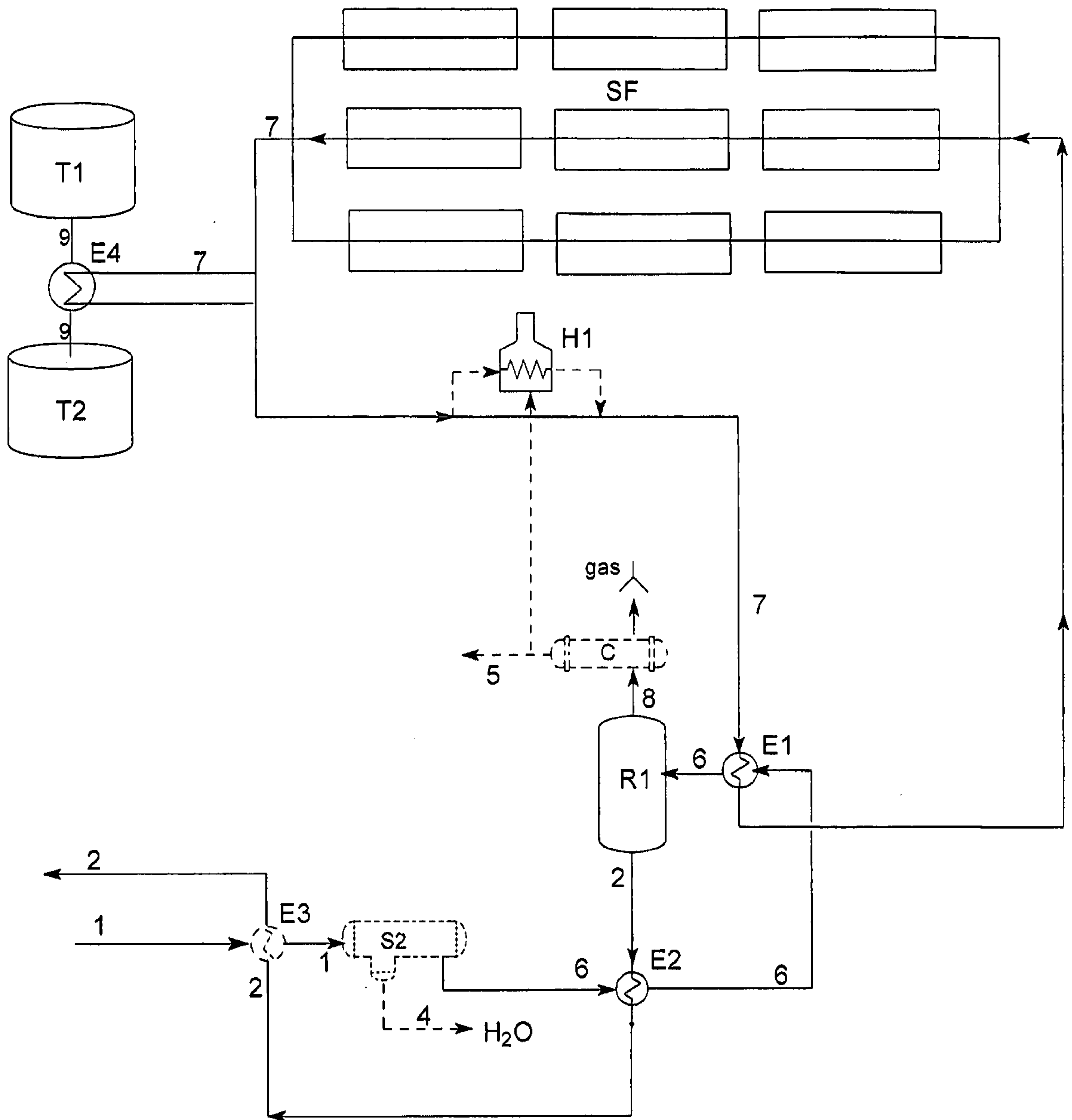

Fig.4

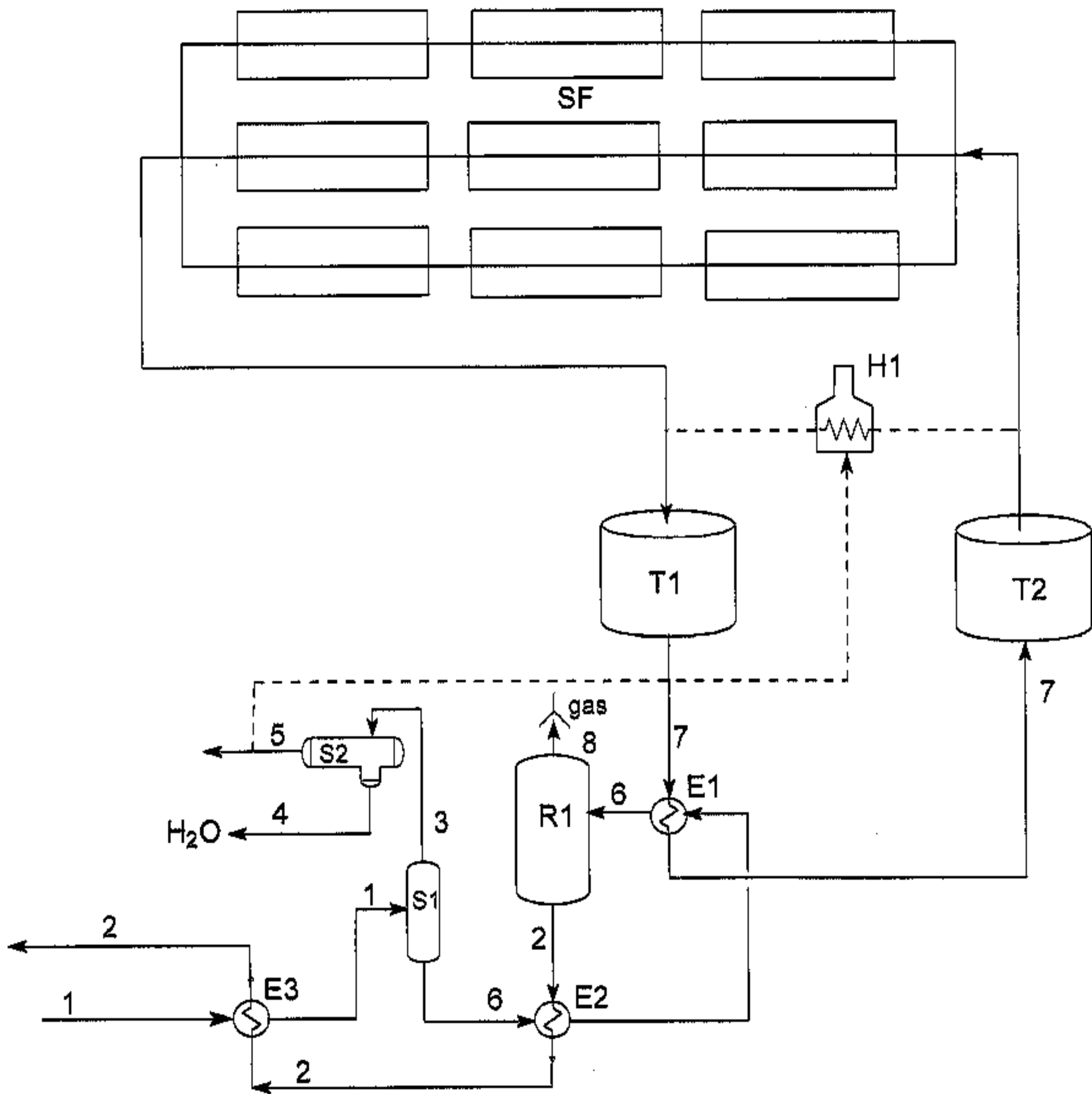

Fig.1