

Sept. 10, 1963

L. JANS

3,103,171

EXPLOSIVE ENGINE

Filed Aug. 17, 1959

FIG. 1.

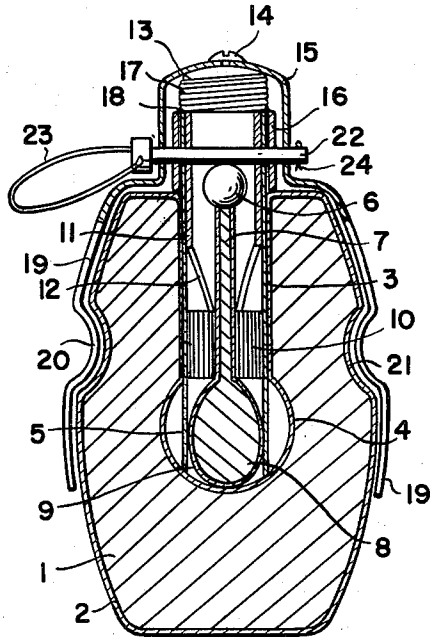
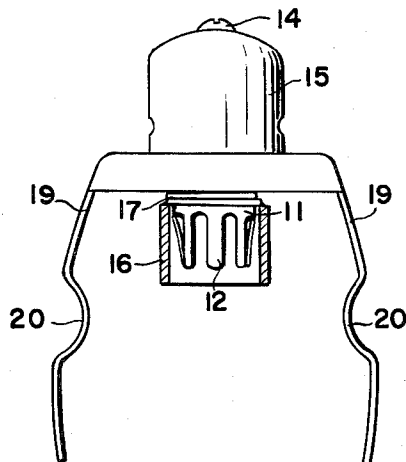

FIG. 2.



INVENTOR.
LEONARD JANS

BY

Robert K. Jacob.

AGENT

1

3,103,171

EXPLOSIVE ENGINE

Leonard Jans, 74 Hertog Reinoudsingel,
Venlo, Netherlands

Filed Aug. 17, 1959, Ser. No. 834,125
5 Claims. (Cl. 102-64)

My present invention relates to an explosive device, such as a hand grenade, a projectile, a mine, a bomb, or any other apparatus of the kind of an explosive device used in warfare to be thrown by hand or by any mechanical device or to be dropped from an aircraft.

The explosive device of the type to which my invention relates, comprises ignition means, an explosive charge, safety means, spring means and locking means which prevent the spring means from operating said ignition means until said locking means have been released. It may further comprise a delay charge intermediate said ignition means and said explosive charge.

It is an object of my invention to provide an explosive device of the kind mentioned above which is entirely harmless to men and thereby is adapted to be used in manoeuvres or sham-fights, even when exploding in the immediate proximity of a participant in the manoeuvres or sham-fights.

Another object of my invention is to provide an explosive engine of the above kind of which, after the engine has been thrown or dropped, all metal or other hard parts which might do harm to men, will leave the engine before the explosive charge explodes.

Still another object of my invention is to provide an explosive device of the above kind which, when used in manoeuvres or sham-fights, is handled substantially in the same way as the corresponding real or live explosive device.

Still another object of my invention is to provide an explosive device of the above kind which is adapted, when used in manoeuvres or sham-fights, to give an indication of loss of men and/or material caused by it, had it been a real or live explosive device.

Still another object of my invention is to provide an explosive device of the above kind which is adapted, when used in manoeuvres or sham-fights in which there are two partaking parties, to give an indication by which of said parties men and/or material are supposed to be hit.

Still a further object of my invention is to provide a hand grenade having locking means which are adapted to be held by the hand of the user against the body of the grenade, thereby preventing spring means to actuate ignition means, so that when the hand grenade is thrown and said locking means are released, said spring means actuates said ignition means and expels all metal or hard parts as a unit from the body of the hand grenade before the explosive charge is ignited via a delay charge.

Still a further object of my invention is to provide an explosive device the body of which is substantially made of clay powder which disintegrates to a cloud of clay dust without leaving any hard particles.

Still a further object of my invention is to provide an explosive device which fulfills one or more of the above objects and at the same time is adapted to be manufactured at low cost.

Other objects and advantages will become apparent from the following description of one embodiment of my

2

invention. In order to explain my invention I have chosen to describe and illustrate the same as applied to a hand grenade although it is also applicable with equal advantages to other explosive engines, e.g. to projectiles, mines or bombs.

In the accompanying drawing in which I have schematically illustrated the example I have chosen:

FIGURE 1 represents an elevational section of a hand grenade embodying the principles of my invention, and

FIGURE 2 represents an elevational side view of those parts of the hand grenade which will be expelled as a unit by the force of spring means before the hand grenade explodes.

The hand grenade according to my invention comprises a body 1 composed of clay powder which may be colored or may be mixed with a colored powder. This powder is enclosed between a thin outer envelope 2 such as a layer of water resistant material and a tubular member 3 having an enlarged portion 4. The thickness of the layer 2 and of the tubular member has been drawn exaggerated in FIG. 1 for the sake of clearness and may consist of some plastic material. A sleeve 5 which is made of rolled paper, e.g. of a kind known as "kraft paper" extends from the bottom of the enlarged portion 4 to beyond the end of the tubular member 3.

The sleeve 5 encloses a cartridge composed of an ignition head 6, a delay charge 7 and an explosive charge 8, said charges being arranged within a common envelope 9, while the head 6 extends beyond said envelope. This envelope may consist of some plastic or any other material, provided that it is adapted to tear to harmless pieces. A collar 10 of rolled paper keeps said unit in its place within the sleeve 5. The ignition head 6 is of a material adapted to be ignited by rubbing faces in the manner of a match head.

A tube 11 which may be made of metal, is located within the sleeve 5 and is formed with tongues 12, the inner sides of which are formed as rubbing faces. The tube 11 has a closed upper end 13 which by means of a screw 14 is fixed to a cap 15 enclosing the upper end of the grenade body 1 and a ring 16 which surrounds the end of the sleeve 5 which extends beyond the upper end of the grenade body. A coil spring 17 surrounds the tube 11, one end of which is welded at 18 to the ring 16. The last coil of the other end of the coil spring 17 is somewhat narrower than the other coils so that it grips the tube 11 near its closed end.

The cap 15 forms one unit with leaf springs 19 having inwardly curved portions 20. The body of the hand grenade is formed with a peripheral groove 21 or with local dents, the shape of which corresponds to that of the portions 20 of the leaf springs 19.

Movement of the cap 15 under the influence of the coil spring 17 is prevented by a latch pin 22 having a pulling ring 23 and extending through the cap 15, the ring 16, the end of the sleeve 5 and the tube 11. A small cotter pin 24 is an extra safety and prevents the latch pin 22 from being inadvertently drawn out when the hand grenade does not need to be ready for immediate use.

The hand grenade according to the invention works as follows, supposing that the cotter pin 24 has been previously removed.

The body of the hand grenade is seized in one hand and the leaf springs 19 are clutched against the body 1, the portions 20 of said springs engaging the groove 21.

By means of the ring 23 the latch pin 22 is pulled out, so that the hand grenade is ready to be used.

If now the hand grenade is thrown, the leaf springs 19 are released, so that by the force of the coil spring 17 the portions 20 of the leaf springs are pulled out of the groove 21. The cap 15 with the leaf springs 19, the screw 14, the ring 16, the coil spring 17 and the tube 11 are flung outwardly as one unit which is illustrated in FIG. 2. During this movement the rubbing inner faces of the tongues 12 strike the head 6, so that it is ignited. The burning head 6 ignites the delay charge 7, so that this charge burns while the metal parts leave the body of the hand grenade. After a determined lapse of time the delay charge 7 ignites the explosive charge 8, so that by the explosion the envelope 9, the sleeve 5 and the tubular element 3 are torn open and the body 1 disintegrates to a harmless cloud of powder.

Having described one embodiment of my invention in the form of a hand grenade, it will be apparent that exactly the same principle may be applied to other explosive devices, such as projectiles, mines or bombs. If applied to a projectile, leaf springs corresponding with the leaf springs 19 of the illustrated hand grenade, will be prevented by the tube of the weapon firing the projectile, e.g. by the tube of a mortar from being bent outwardly. Also when applied to mines or bombs thrown from an aircraft, the springs are held against the body of the mine or the bomb by the guiding tube or other element of the aircraft.

It will also be apparent that my invention is not limited to the use of special materials nor to particular forms of the components.

The clay powder of which the grenade body is composed may be colored or may be mixed with colored powder. If then the hand grenade or other explosive device explodes near a soldier, the cloud of clay dust leaves a colored stain on his uniform thereby establishing that he is supposed to have been hit by the grenade or other device. If both parties in a manoeuvre use clay powder of different colors, it can thus be established by which party the hand grenade has been thrown.

While I have shown and described one embodiment of my invention, what I claim is:

1. An explosive device comprising two relatively separable interconnected parts, one of said parts comprising a body disintegrable into a cloud of harmless particles, said body being formed as a single unit and having a tubular cavity, an explosive charge being arranged within said cavity and a delay charge having an ignition head being arranged adjacent said explosive charge for igniting said explosive charge, the other of said parts constituting a unit comprising a cap partly covering said body, means extending from said cap about said body for releasably engaging and interlocking with said body, spring means mounted within said cap for biasing said parts apart and ignition means secured to said cap for igniting said ignition head and thereby said delay charge upon separation of said parts, said device further including safety means for preventing said spring means from separating said parts and operating said ignition means until released, said interlocking means of said cap being adapted to be held in interlocking position with said body after said safety means has been rendered inoperative, and said spring means upon release of said interlocking means being operative to separate said cap, said means extending from said cap, said spring means and said ignition means from said body and said explosive charge before explosion of said charge.

2. An explosive device comprising two relatively separable parts, one of said parts comprising a disintegrable non-explosive body of compressed powder defining a cavity, said body being covered with a thin layer of water resistant material and a time delayed explosive charge arranged within said cavity, the other of said parts constituting a unit comprising a cap for covering said cavity,

said cap having a pair of arms extending therefrom for releasably gripping and interlocking with said body, spring means mounted within said cap for biasing said parts apart and ignition means secured to said cap for rubbing against and igniting said charge upon separation of said parts, said device further including safety means for preventing said spring means from separating said parts and operating said ignition means until released, said gripping means of said cap being adapted to be held in interlocking position with said body after said safety means has been rendered inoperative, said spring means upon release of said interlocking means being operative to separate said cap, said arms, said spring means and said ignition means from said body and said charge before explosion of said charge.

3. A hand grenade of the kind wherein an explosive charge is set off by releasing one or more parts normally held together comprising two relatively separable parts, one of said parts comprising a disintegrable body of non-explosive compressed powder and defining a cavity, said body being covered with a thin layer of water resistant material, an explosive charge arranged within said cavity, a delay charge having an ignition head arranged within said cavity for igniting said explosive charge and a groove arranged in the outer periphery of said body, the other of said parts constituting a unit comprising a cap for closing said cavity, said cap having a pair of arms extending therefrom for releasably engaging said body, said arm each having a protrusion for extending into said groove and interlocking with said body, spring means mounted within said cap for biasing said parts apart and ignition means secured to said cap for rubbing against and igniting said ignition head and thereby said delay charge upon separation of said parts, said device further including a latch pin extending through said cap and said body for preventing said spring means from separating said parts and operating said ignition means until removed, said arms of said cap being held in interlocking position with said body by the hand of an operator against the bias of said spring means after said latch pin has been removed, said spring means upon release of said arms by the operator being operative to separate said cap, said arms, said spring means and said ignition means from said body and said charge before explosion of said charge.

4. A hand grenade comprising two relatively separable parts, one of said parts comprising a disintegrable body of compressed non-explosive powder defining a cavity, said body being covered with a thin layer of water resistant material, a groove arranged in the outer periphery of said body, a non-metallic disintegrable cylinder mounted in said cavity, an explosive charge arranged within said cylinder and a delay charge having an ignition head arranged within said cylinder for igniting said explosive charge, the other of said parts constituting a unit comprising a cap for covering said cavity, said cap having a pair of leaf springs extending therefrom for releasably engaging the outer periphery of said body, said leaf springs having means for extending into said grooves and interlocking with said body, a coil spring mounted on said cap and extending between said cap and the end of said cylinder for biasing said parts apart and friction means secured to said cap for rubbing against and igniting said ignition head and thereby said delay charge upon separation of said parts, said device further including a latch pin extending through said cap and said cylinder for preventing said coil spring from separating said parts and actuating said friction means until removed, said leaf springs of said cap being held in interlocking position with said body by the hand of an operator against the bias of said coil spring after said latch pin has been removed, said spring means upon release of said leaf springs by the operator separating said cap, said leaf springs, said coil spring and said friction means from said disintegrable non-explosive body, said cylinder and said explosive charge.

5

5. The combination set forth in claim 4 wherein said powder is clay having a colored appearance.

References Cited in the file of this patent

UNITED STATES PATENTS

1,265,701	Clark -----	May 7, 1918	2,105,528
1,316,367	Knight et al. -----	Sept. 16, 1919	2,393,861
1,539,609	Taylor -----	May 26, 1925	2,714,353
2,104,508	Demeter -----	Jan. 4, 1938	2,872,866
			2,922,367
			2,932,251
			1,097,305

6

Foisy -----	Jan. 18, 1938
Miller -----	Jan. 29, 1946
Greer -----	Aug. 2, 1955
Brown et al. -----	Feb. 10, 1959
Dunzer -----	Jan. 26, 1960
Hamilton -----	Apr. 12, 1960
FOREIGN PATENTS	
France -----	Feb. 16, 1955