

E. THOMSON.  
ELECTRIC ARC LAMP.

No. 525,035.

Patented Aug. 28, 1894.

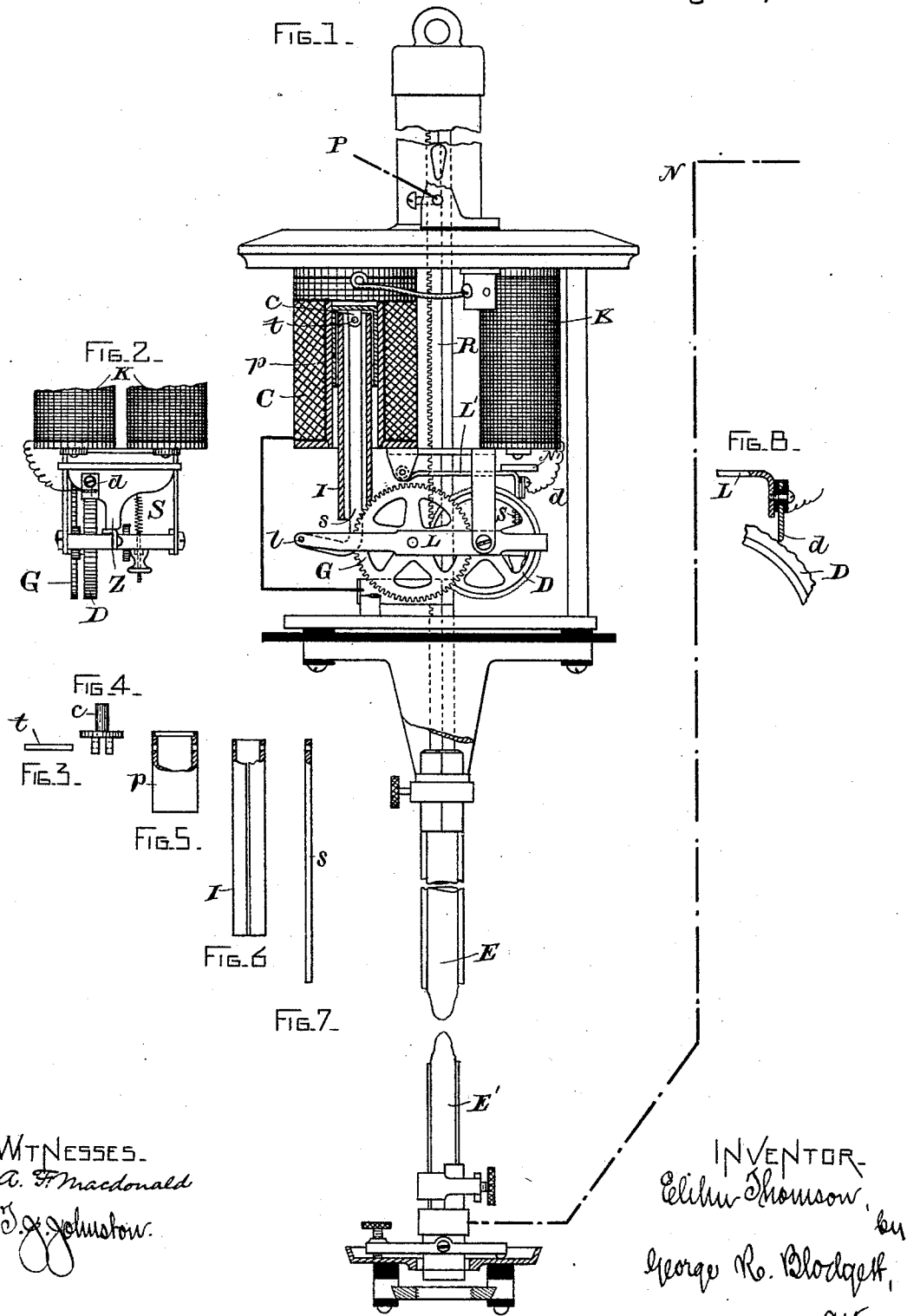

WITNESSES.  
A. F. Macdonald  
J. Johnston.

INVENTOR  
Elihu Thomson,  
by  
George R. Blodgett,  
Atty.

E. THOMSON.  
ELECTRIC ARC LAMP.

No. 525,035.

Patented Aug. 28, 1894.

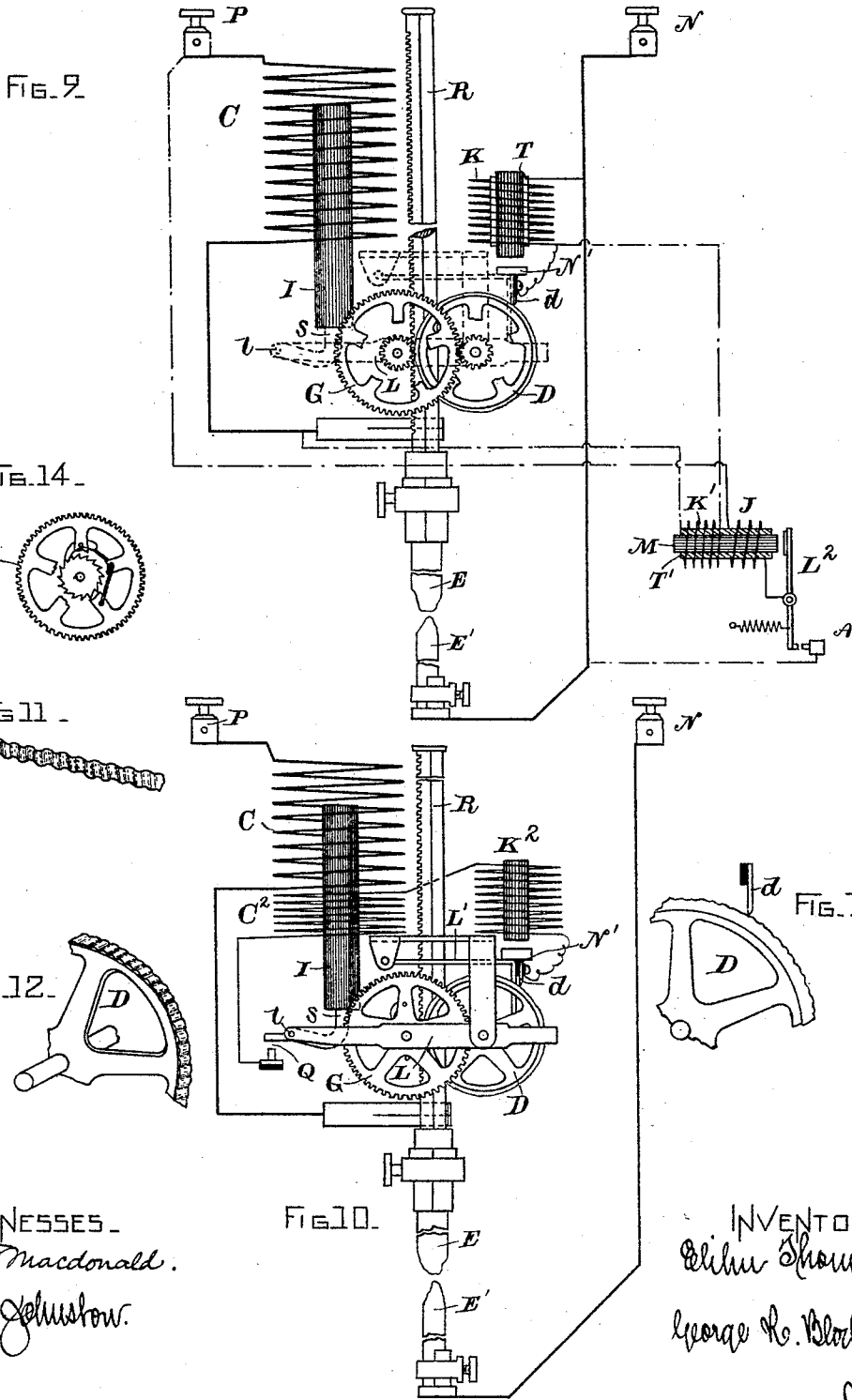

WITNESSES -  
*a. F. Macdonald.*  
*E. Thomson.*

INVENTOR  
*Elihu Thomson,*  
*George R. Blodgett,*  
*Att'y.*

E. THOMSON.  
ELECTRIC ARC LAMP.

No. 525,035.

Patented Aug. 28, 1894.

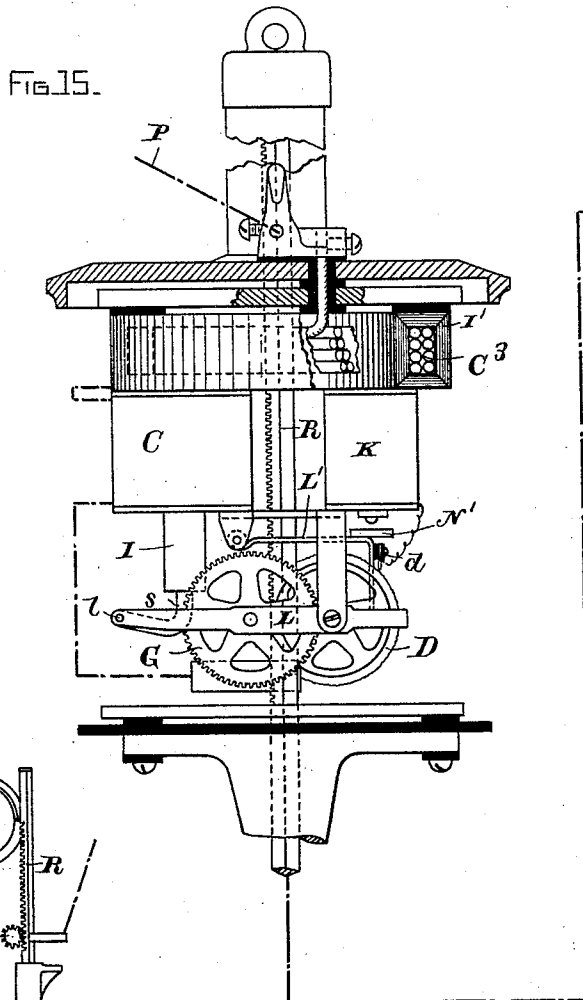

FIG. 16.

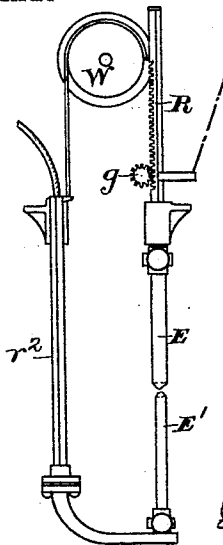
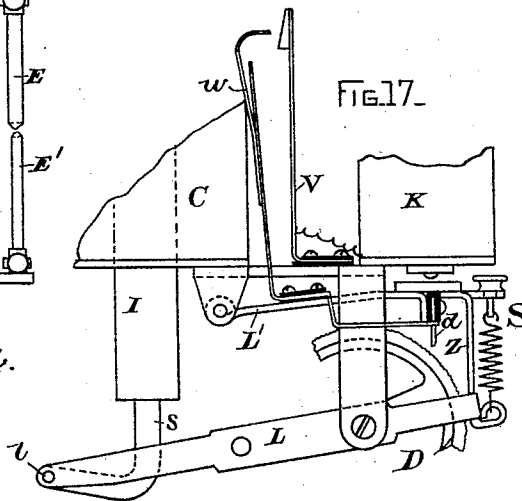

FIG. 17.



WITNESSES.  
*A. F. Macdonald.*  
*J. J. Plustow.*

INVENTOR-  
*E. Thomson,*  
*George H. Blodgett,*  
*Atty.*

# UNITED STATES PATENT OFFICE.

ELIHU THOMSON, OF SWAMPSCOTT, MASSACHUSETTS, ASSIGNOR TO THE  
GENERAL ELECTRIC COMPANY, OF NEW YORK.

## ELECTRIC-ARC LAMP.

SPECIFICATION forming part of Letters Patent No. 525,035, dated August 28, 1894.

Application filed May 16, 1894. Serial No. 511,408. (No model.)

*To all whom it may concern:*

Be it known that I, ELIHU THOMSON, a citizen of the United States, residing at Swampscott, county of Essex, State of Massachusetts, have invented certain new and useful Improvements in Electric-Arc Lamps, of which the following is a specification.

My invention relates to electric arc lamps; and has for its object the production of a cheap and effective arc lamp adapted for use on continuous current circuits, although with suitable modifications to be described, it may be operated on alternating current circuits. By my improved construction I secure a simple arc lamp, which, when desired, can be adjusted so that at a certain strength of current its action shall be like that of a differential lamp, wherein one magnet in the direct circuit acts differentially or pulls against another magnet in the derived circuit around the lamp; although the action is not differential, but reproduces the effects of differential lamps. With a little higher strength of current, the lamp regulates its arc entirely by the action of the shunt or derived circuit magnet: this variation may be accomplished for the normal current by a simple change in the effect of the main circuit winding, as by shunting it or varying its turns.

In some respects the present invention is an improvement upon the invention described in my Patent No. 250,463, issued December 6, 1881, while it contains other matters which are different therefrom. The lamp constructed according to my invention is particularly designed for use on constant potential circuits, or "incandescent" circuits, as they are called, in which a potential of one hundred and ten volts (or other low voltage), is used to operate two arc lamps in series, including a damping or choking coil in the series. My invention however is not limited to such conditions of service, as by modifications to be pointed out it may be applied on series or alternating current circuits.

In the drawings hereunto annexed and hereby made part of this specification, like letters refer to like parts throughout; and therein—

Figure 1 is a side elevation, partly in section, of a lamp embodying my invention.

Fig. 2 is a rear elevation of the shunt magnet and feeding mechanism. Figs. 3, 4, 5, 6 and 7 show details of the dash-pot or pneumatic check which I employ. Figs. 8, 11, 12 and 13 show the detent and detent wheel of the feed mechanism. Fig. 9 shows in diagram the connections of the lamp with a suitable cut-out. Fig. 10 is a similar view of a modified form of a lamp adapted to alternating current circuits. Fig. 14 shows the connection of the rack-rod to the gear. Fig. 15 is a diagrammatic view, partly in section and partly in elevation, of a lamp provided with my improved impedance or steadying coil. Fig. 16 is a view of the focussing arrangement which I employ, and Fig. 17 shows the method of arranging the detent *d* and the detent wheel *D* to prevent arcing between them.

In Fig. 1 the upper carbon electrode *E* is carried on a rack-rod *R*, the lower electrode *E'* being stationary; this rack-rod engages with a pinion on a shaft, which bears a large gear *G*, the teeth of which engage in a pinion, seen in Fig. 9, on a second shaft to the right, which second shaft carries a detent wheel *D* of peculiar construction, to be hereinafter described. A lever frame *L*, pivoted concentrically with the wheel *D*, incloses the wheel work, mounts the shaft in place, and is connected to an iron core *I*, which, when attracted, raises the rack-rod *R*, by raising the gearing *G* and pinion on the same shaft with *G*, with which the rack-rod meshes. The core *I* moves in the axis of a solenoid coil *C* carrying the main current of the lamp, which enters at *P*, passing through the coil *C*, thence to the frame work or to the spring bearing on the rack-rod as usual, and leaving the lamp at *N*; this connection is shown dotted because in ordinary cases it follows the frame work and goes to the negative binding post of the lamp.

*K* is a derived circuit magnet, wound with fine wire and connected by one of its terminals to the negative side of the lamp as usual, and by the other terminal to an insulated detent *d* carried on its own armature lever; the detent when down on the wheel *D* completes the shunt connection from the frame work of the lamp through the magnet *K* to the terminal *N*. While the coil *C* may be an inclosing solenoid, I prefer to make the magnet *K* of

two coils as in ordinary electro-magnets. These are indicated at K, K, Fig. 2, which is a view at right angles to Fig. 1. The armature N' of the magnet K is shown at a little distance away, the pawl *d* resting in the fine teeth of the detent wheel D. An adjustable spring S is arranged to pull the armature N down toward the frame L to the right of its pivotal point, so that any downward movement of the core I will relax the spring S, and its upward movement will tighten the spring. Hence when the core I moves up or down by variations of current in the coil C, the tension of the retractile spring and the action of the shunt magnet K is varied likewise; this feature I have described and claimed in my Patent No. 261,790, issued July 25, 1892. I also provide a stop Z on the armature N' of the shunt magnet K, K, which when the armature is down and the frame L, owing to the descent of the core I, has dropped the gear G, causes the end of the lever frame to raise the detent *d* from the teeth of the wheel D, and so release the mechanism, whereupon the current is immediately weakened or taken off the lamp altogether. It will readily be seen that the descent of the core I, followed by the descent of the left hand portion of the lever frame L, causes a rise of its right hand end and the elevation of the stop Z thereon, thus forcing the armature N' toward the magnet K, K positively, and raising the detent *d*. I prefer to combine the core I or other parts in such a way as to provide a dash-pot or air cushion, although a separate dash-pot or air cushion for checking the movements might be introduced. To this end the coil C is wound upon a brass tube and the core I, as in Figs. 3 to 7, is made up of a piece of iron pipe I, on the upper part of which is strung a piston of brass or other suitable metal *p*, mounted on a cap *c*, which also acts as a stop and prevents the core I being pulled too far into the coil C, a projection on the cap *c* being provided; as shown, which abuts on the head of the cylinder or dash-pot tube above. A bent connecting rod *s* enters the hollow piston I, and engages near the point *l*, Fig. 1, with the lever frame L. A single pin *t*, Fig. 3, inserted through openings in the piston, in the upper end of the core I, in depending lugs on the cap *c* and in the upper end of the connecting rod *s*, ties all these parts together before their insertion in the cylinder upon which the coil C is wound, after which the pin *t* cannot escape or be disengaged without withdrawing the parts.

A portion of the rim of the detent wheel D and the insulated detent *d*, carried by the armature lever L' of the magnet K, is shown separately in Fig. 8. I make the detent or pawl *d* of silver and I also either silver plate or place a corrugated strip of silver on the periphery of the detent wheel D. In Fig. 11 I show a strip of thin sheet silver which is suitably corrugated and bent around the periphery of the detent wheel D, as indicated

in Fig. 12, and secured thereto in any suitable way, as by soldering. This gives a succession of moderately fine rounded teeth, and is cheaply produced, while it permits also the use of the preferable metal silver for the periphery of the wheel.

A skeleton view of the connections and arrangements of the lamp is shown in Fig. 9, and will be understood from what has gone before in the way of descriptive matter. It should be stated here that I prefer to surround the core of the magnet K with a copper tube or good conductor, as indicated at T, Fig. 9, so as to make its action moderately sluggish and also to abolish sparking at the contacts by annulling the self-induction of the winding. As indicated in Fig. 14, I prefer not to fasten the wheel G firmly to its axis, but to arrange a ratchet connection, as usual, so that the rock-rod R may run upward without rotating the mechanism, but on the downward motion the wheel work will turn. The action of the lamp as thus far described is very similar to that which is set forth in my Patent No. 250,463, and may be briefly stated as follows: On the passage of the current through the lamp with the detent *d* in an up-raised position, with the main core I down, the wheel work is free so that the carbons are always in contact, the current passes through the solenoid coil C and then through the carbons E, E', and out at the negative terminal. This causes an attraction and uplifting of the core I, which raises the frame L, lifting the pinion *g*, Fig. 9, meshing with the rack-rod; but on the instant of such uplifting the armature lever L' is released and the detent *d* falls into place on the edge of the wheel D, stopping the wheel work. Hence any further motion upward raises the carbon rack-rod and starts an arc. This arc continues until by the increase of the current in the shunt magnet it attracts its armature against the action of the spring S, and in so doing opens its own circuit between the detent *d* and the wheel rim of D, at the same time releasing a tooth on the wheel, which slips by the detent. The lifting of the detent *d* however so weakens the magnet K that a re-engagement of the detent wheel at once takes place, and the feed of the lamp is perfectly positive as well as delicate and is accomplished with practically little or no spark between the detent *d* and the rim of the wheel D. If the force of the current in C is great enough to pull the core up to its highest point, as limited by the projection on the piston cap *c*, Fig. 4, then the spring S, Fig. 2, becomes set at a given force and the lamp feeds always when such force is overcome by the pull of the magnet K, a fraction of a volt being generally sufficient to determine whether or not the lamp shall feed. If however the force of the current or the turns of the coil C or the weight of the core and frame work which it lifts, are such that the core floats, as it may be called, or the projection on the cap *c* does

not strike, then the action of the shunt magnet is dependent on the position of the core I as determined by the current in C rising or falling, because the retractile force of the spring S when the core I is floating is variable according to the position of the lever frame L. In such cases the feeding action of the lamp is dependent on the current as well as on the voltage of the arc, and may be made to closely approximate the differential action of a good differential lamp. As described, the lamp is adapted perfectly to operate on constant potential circuits.

If a number of lamps are to be operated in series on a circuit, a cut-out is needed in case of a failure to feed, and a suitable cut-out is shown in Fig. 9 connected by dotted lines. A small electro-magnet with an armature and contact making lever is shown at M, L<sup>2</sup>. On the magnet is placed a heavy copper casing or tube T' to render its action quite sluggish. Wound upon the core is also a winding K' of fine wire and comparatively high resistance, which is placed in shunt to the detent *d* and the wheel D, so that when the detent leaves the wheel, the fine wire K' is in circuit in series with the wire on the magnet K, or in derived circuit around the arc, but when the detent *d* touches the wheel rim, K' is shunted. If by failure to feed, the detent *d* leaves the wheel frequently, or vibrates rapidly thereon, it energizes the shunting fine wire coil K' sufficiently to cause the armature of the magnet M to be attracted and close the contact at A, thereby causing the current to pass through a second winding, J, of coarse wire, which connects the terminals of the lamp through the contact A, and so maintains the force of the magnet M, keeping the contact A closed until the carbons E, E', are brought together to again shunt the coil J. While in this arrangement the fine wire coil K' has been placed in shunt around the contact between the detent *d* and the wheel D to act as a cut-out in case of a failure to feed, it is manifest that a coil of considerable resistance may be used around the contact irrespectively of its cut-out function. This however is not desirable in case of lamps working on constant potential circuits, while it might be desirable on lamps working on constant current or in series with other lamps.

To adapt the lamp to operate satisfactorily and readily on alternating circuits of constant potential and not in series with other lamps, the arrangement may be modified as shown in Fig. 10. In this case the core I is of course laminated and divided so as to cut off eddy currents in it, while the main current coil C acts to lift the laminated core and create the arc in the same way as in Figs. 1 and 9, but the feeding is effected by a simple weakening of the current due to the lengthening of the arc established between the carbons E, E'. The core I therefore descends and closes a contact at Q on the end of the lever frame L. The contact Q is in circuit

with a coil C<sup>2</sup> around the laminated core I, forming a secondary to the main coil C, which thus becomes the primary of a transformer or induction coil. The coil C<sup>2</sup> is in circuit with the coil on the feeding magnet K<sup>2</sup>, and the detent *d* and wheel D also form a contact in this local circuit, which depends for its current on induction from the main coil C acting on the coil C<sup>2</sup> as a secondary. When the contact Q closes, detent *d* will be down, but will be at once lifted by the energizing of the magnet K<sup>2</sup> by the induced currents from C<sup>2</sup>. The lamp will therefore feed by the raising of the detent *d*, but as this detent breaks the local circuit on its rise, the feeding is interrupted and can only take place by renewed breaks or liftings of the armature of the magnet K<sup>2</sup>. Hence the feeding is gradual and continuous until the carbon is fed to a sufficient extent to slightly increase the current in C and open contact Q. Where the lamps are to be used in series on alternating circuits, the arrangement of the circuits may be as in Fig. 9 with the exception of the damping tube T' on the magnet M which should have a laminated core and be wound so as to be put into derived circuit around the arc. There is apt to be more spark at the contacts between *d* and D in such an arrangement than is desirable, and hence a "dead" resistance shunt taking the place of K' should in such cases be employed around said contact. To render the current steady when such a lamp is used on alternating current circuits of constant potential, I prefer to employ an inductive coil which acts to prevent sudden fluctuations in the strength of the current; as shown in Fig. 15, this coil may be conveniently placed in the top of the lamp box, and may comprise a number of turns of wire C<sup>3</sup> conveying the main current to the lamp, surrounded by an iron core I', of circular form preferably, and arranged so that the heat generated by the coil passes off freely from the upper part of the lamp. This coil acts by its impedance, that is, by its resistance and self-induction combined, to steady the current. Below it is mounted the mechanism, such as has been described in the preceding figures, or other suitable feeding mechanism. The main line circuit is shown in heavy dotted lines passing from the insulated binding post through the impedance coil and thence through the arc producing magnet coil C, and then through the carbons of the lamp.

It is sometimes desirable to construct the lamp of my invention so that both carbons are moved, the lower carbon upward and the upper carbon downward, and if the relative sizes of the carbons be selected so that the rate of burning is the same for the lower and upper carbon, a focussing action is easily obtained by the device shown in Fig. 16. Here the rack-rod R is carried on the pinion *g* as in the figures preceding. A cord or chain attached to the rack-rod at a point adjacent to

the wheel W passes over the wheel, which is free to move on its pivots suitably mounted in the lamp case, and the other end of the cord is carried on a second rod  $r^2$  which serves as the means of sustaining the carrier of the lower carbon. The rack-rod R and the rod  $r^2$  may be square and pass through suitable openings in the frame, as indicated, such openings embracing enough of the rod to form efficient guides and allow free vertical movement. The rod  $r^2$  is made tubular and the lower carbon carrier is insulated therefrom, an insulated conductor passing down through the rod  $r^2$  connecting the lower carbon carrier to the negative terminal of the lamp.

In some cases in which the potential of the circuit on which the lamp is run is moderately high, the dropping of the core I, owing to the cessation of current on the burning out of the carbons, might cause the detent  $d$  to be lifted from the wheel D when sufficient potential exists across the break or separation to maintain a small current in the form of a diminutive arc. This would eventually damage the structure by burning the insulation and by injuring the metal surfaces. If the separation at  $d$  were increased in range, this difficulty would be obviated, but another means for obviating it and avoiding the difficulty is to make a second break in the connection from the shunt magnet K to the detent in series with the break at  $d$ . To this end I fix an insulated strip V to the frame of the lamp, having a contact piece at its upper end, while another piece  $w$  is insulated on the armature lever  $L'$ . This last piece  $w$  is connected to the detent pawl  $d$  and moves with it. When the armature lever  $L'$  is down, the contact will be made between  $w$  and V, and also between  $d$  and the wheel D, both in series with the shunt coil K. When however by the fall of the core I the armature lever  $L'$  is lifted to open the contact at  $d$ , the contact between  $w$  and V is at the same time opened to a considerable extent on account of the leverage given to them. One or both of the contacts,  $w$  or V, I make flexible, and the opening of the contact is just after the opening of  $d$ , and its closing likewise, is just before the closing of  $d$ .

What I claim as new, and desire to secure by Letters Patent of the United States, is—

1. In an electric arc lamp, a series coil, a core reciprocating therein, a frame pivoted to the frame of the lamp and actuated by such core, gearing carried in the frame, a rack-rod for the upper carbon meshing with such gearing, a detent engaging with the gearing and fixed to an armature; a damped shunt magnet actuating the detent, and a stop affixed to the frame and arranged, substantially as described, to lift the detent when the current ceases.

2. The method of operating an alternating current arc lamp, which consists in actuating the magnet controlling the feed with current

induced from the main or arc-producing current.

3. The method of operating an alternating current arc lamp, which consists in actuating a magnet controlling the feed with current derived from a secondary coil in inductive relation to the series coil of the lamp.

4. In an electric arc lamp, a main circuit, a second circuit inductively related thereto and feeding mechanism controlled by the induced current.

5. In an electric arc lamp, a series or arc-striking coil, a second coil inductively related thereto, and feeding mechanism controlled by the induced current.

6. In an electric arc lamp, a series circuit, a transformer in such circuit, a magnet in the secondary circuit of the transformer, and feeding mechanism controlled by the magnet.

7. In an electric arc lamp, the combination of a series coil, a second coil in inductive relation thereto, a magnet in the circuit of the second coil, a detent actuated by the magnet, gearing operated by the series coil, and a contact adapted to close the circuit through the second coil and the feed magnet.

8. In an electric arc lamp, a series coil, a core for such coil, a second coil in inductive relation to the series coil, a magnet in the circuit of such second coil, a detent actuated by the magnet, a frame connected to the core of the series coil and containing the gearing, a rack-rod meshing with the gearing, and a contact actuated by the movement of the core or frame and arranged and adapted, as herein described, to complete the circuit through the second coil upon the descent of the core.

9. In an electric arc lamp, a series coil, a core reciprocating in such series coil, a frame pivoted to the frame of the lamp and connected to such core, gearing in the frame, a rack-rod for the carbons meshing with such gearing, a detent preventing the descent of the carbon, a magnet operating such detent, a second coil upon the same core with the series coil, a circuit including the detent, the magnet and the second coil, and a contact adapted to close such circuit upon the descent of the carbon; whereby the inductive current in the second coil is caused to operate the detent and release the gearing to feed the lamp by a step-by-step or incremental motion.

10. In an electric arc lamp, a detent wheel for the gearing comprising a corrugated strip of silver secured to the rim of a wheel.

11. In an electric arc lamp, a dash-pot for the core of the series coil comprising a tube provided with a cap adapted to register with the shell of the solenoid, a smaller tube comprising the iron of the core, and a rod arranged to connect with the moving part of the lamp; the parts being secured together by a single pin, as herein set out.

12. In an electric arc lamp, a cut-out comprising the following elements; a contact closing a circuit around the lamp, a magnet adapted to actuate the contact and having

two windings, feeding contacts for the lamp, a circuit in shunt to such feeding contacts including one of the windings upon the magnet, the other winding being included in the circuit around the lamp closed by the contact, substantially as described.

13. In an electric lamp, a series coil, the gearing actuated thereby and adapted to separate the carbons to establish an arc, a shunt feeding coil arranged to release the gearing and feeding the carbons together, and a cut-out comprising an electro-magnet having thereon a closed conductor and two energizing windings, one a shunt around contacts in the circuit of the shunt feeding magnet of the lamp and the other a coarser winding for conveying the main current, and contacts completing the circuit through said coarse winding and adapted to be closed by the armature of said magnet.

14. In an electric arc lamp, the combination of a series magnet for establishing the arc, a

shunt magnet adapted to feed the carbons toward each other by the separation of contacts in its own circuit, a circuit in shunt to said contacts, and a cut-out adapted to be actuated by the current flowing in said shunt circuit.

15. In an electric arc lamp, operated by gearing and provided with a gear detent wheel *D* and a detent *d* actuated by the shunt magnet of the lamp and included in its circuit, a second or auxiliary break having flexible contacts and included in the shunt circuit of the lamp; all arranged as herein described, to prevent the formation of an arc between the detent and the detent wheel.

In witness whereof I have hereunto set my hand this 14th day of May, 1894.

ELIHU THOMSON.

Witnesses:

JOHN W. GIBBONEY,  
HENRY O. WESTENDARP.