

(No Model.)

3 Sheets—Sheet 1.

R. D. GATES.
ROCK OR ORE BREAKER.

No. 525,144.

Patented Aug. 28, 1894.

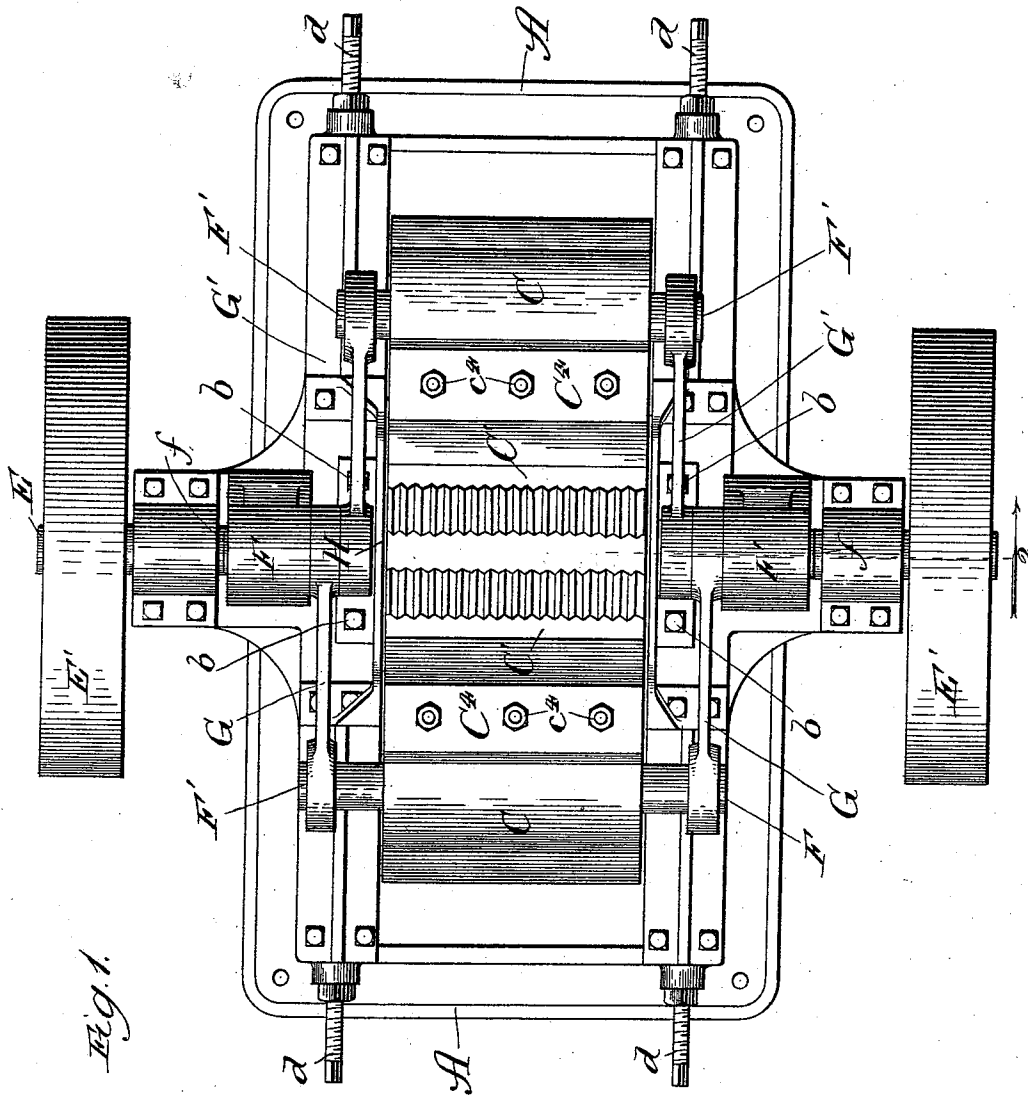

Witnesses:
Chas. C. Gaylord
Clifford N. H. Lott

Inventor:
Ryerson D. Gates
 By *Benjamin D. Manning* & *Benjamin D. Ryerson*
Attys.

(No Model.)

3 Sheets—Sheet 2.

R. D. GATES.
ROCK OR ORE BREAKER.

No. 525,144.

Patented Aug. 28, 1894.

Fig. 2.

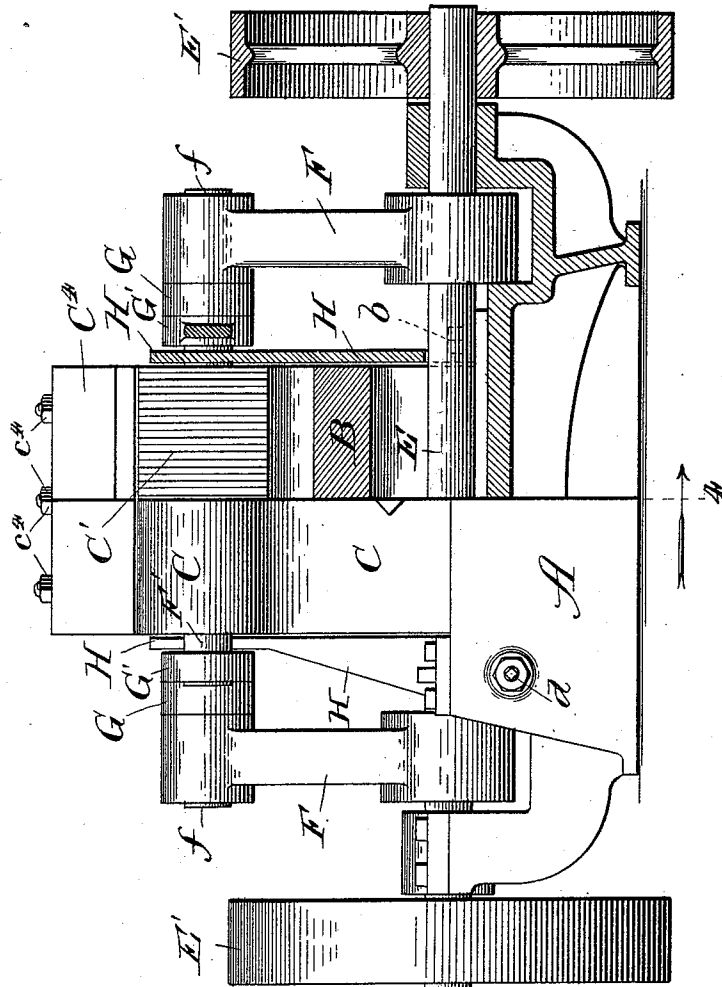

Witnesses,
Charles C. Hayward
Clifford A. White

Inventor:
Ryerson D. Gates
By *William C. Manning* & *William C. Taylor*
Attys

(No Model.)

3 Sheets—Sheet 3.

R. D. GATES.
ROCK OR ORE BREAKER.

No. 525,144.

Patented Aug. 28, 1894.

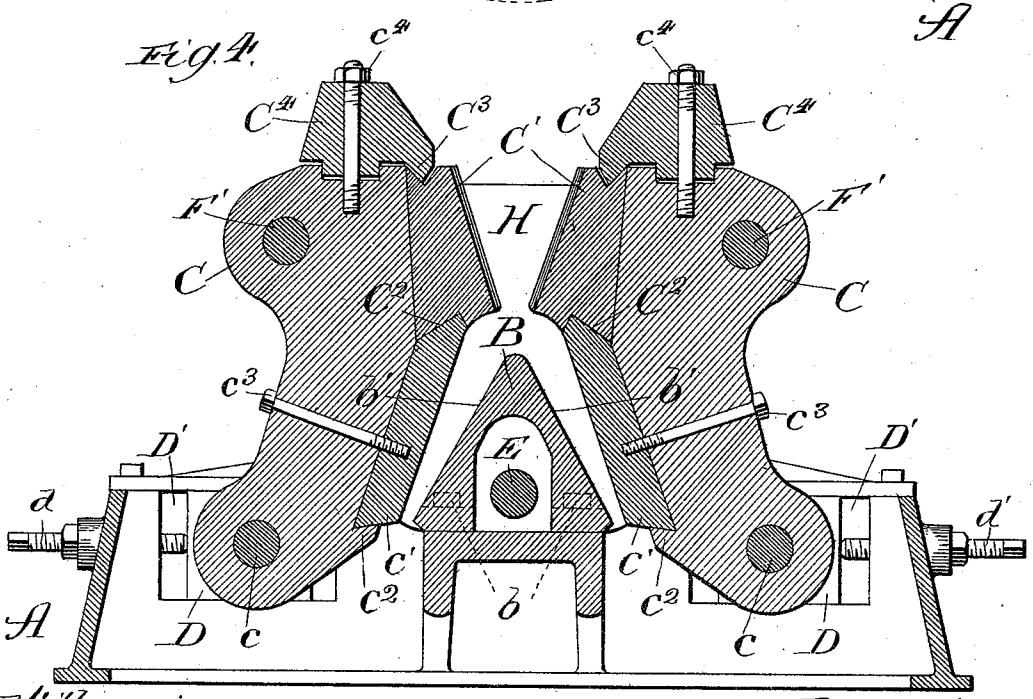
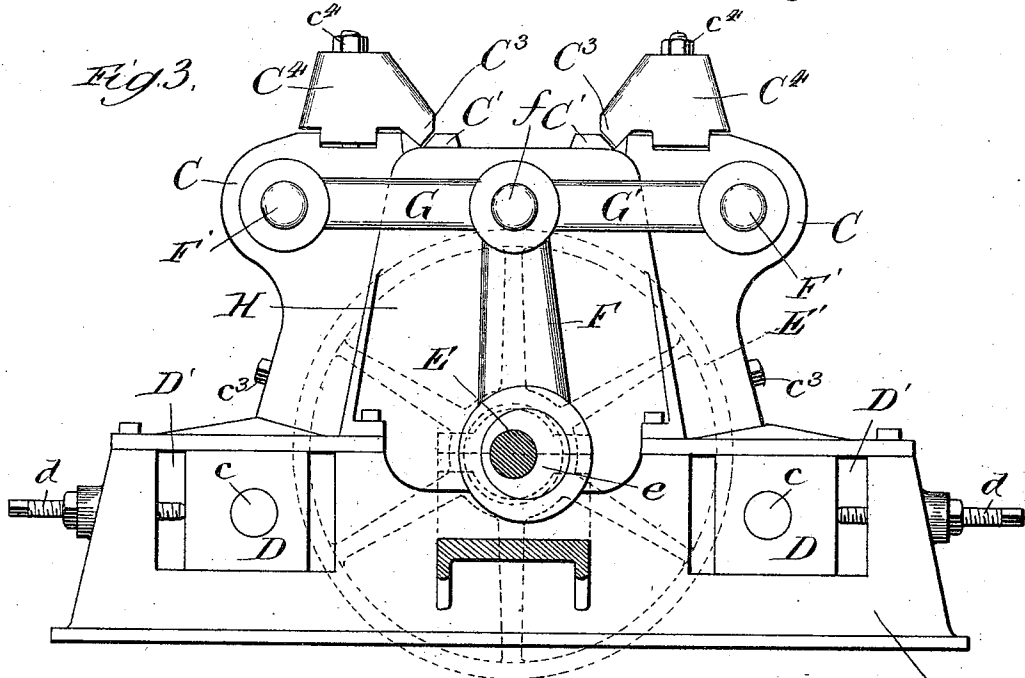

Witnesses:
Edw. C. Bayford,
Clifford H. White.

Inventor:
 Ryerson D. Gates.
By *James C. Bayford,*
Attorney.

UNITED STATES PATENT OFFICE.

RYERSON D. GATES, OF OAK PARK, ILLINOIS.

ROCK OR ORE BREAKER.

SPECIFICATION forming part of Letters Patent No. 525,144, dated August 28, 1894.

Application filed February 28, 1893. Serial No. 464,042. (No model.)

To all whom it may concern:

Be it known that I, RYERSON D. GATES, a citizen of the United States, residing at Oak Park, Cook county, Illinois, have invented certain new and useful Improvements in Rock or Ore Breakers, of which the following is a specification.

In the drawings, Figure 1 is a plan view of my improved breaker. Fig. 2 is an end view, partly in section, the section being on line 2 of Fig. 1. Fig. 3 is a side elevation, partly in section, the section being on line 3 of Fig. 1. Fig. 4 is a longitudinal vertical section taken in the line 4 of Fig. 2.

In making my improved rock and ore breaker, I employ a base A, on which the operative parts are mounted. I arrange on the base a central crushing anvil, B. This anvil is fastened to the base by bolts *b*, or in such other desired manner as may be preferred to hold it securely in place. The crushing anvil is provided with two inclined crushing surfaces, *b'*, inclining toward each other at the top, so as to give to the crushing anvil a substantially triangular form, as shown in Fig. 4.

The anvil is preferably made with a hollow core to permit the arrangement of parts, as hereinafter described. I arrange two rocking or oscillating crushing jaws, C, pivoted to the base on shafts, *c*, so as to permit them to be rocked or oscillated on their pivotal points. These crushing jaws are provided with crushing surfaces or plates, *C'*, which, for convenience, will be termed the initial crushing surfaces, and with crushing surfaces, *c'*, which for convenience will be termed secondary crushing surfaces. As the jaws are rocked or oscillated inward, the initial crushing surfaces approach as nearly to each other as desired, in the operation of the machine, and the secondary crushing surfaces approach as nearly as may be desired to the crushing surfaces of the anvil.

The crushing surfaces on the jaws are preferably made of hardened or chilled material to better enable them to resist the wearing action of the rock or ore being crushed. The secondary crushing surfaces, when thus made in separate plates, are preferably let into the jaws the desired distance, and are supported on shoulders *c²*, to sustain their weight, while

they are held in their places by bolts, *c³*. The upper ends of the secondary crushing surfaces are preferably beveled, so that correspondingly beveled notches, *C²*, in the lower ends of the initial crushing plates fit over them, so that the weight of such plates may be thus sustained.

The upper ends of the initial crushing plates are preferably provided with beveled notches, in which the edges *C³* of caps *C⁴* rest. These caps are preferably let into the upper edges of the crushing jaws, and held securely in place by bolts, *c⁴*. The shafts on which the lower ends of the jaws are pivoted, are mounted in blocks, D, arranged in guides or ways *D'* or otherwise arranged so that they can be adjusted in or out by means of the bolts *d*, so that the distance between the lower edges of the secondary crushing plates and the central anvil may be regulated to determine the fineness and the rapidity of the flow of the material through them, so that they may be adapted to crush or pulverize the material as finely or as coarsely as may be desired.

The jaws may be adjusted at different positions of nearness to the anvil, so that the material flowing from one side of the anvil may be finer than the material flowing from the other, and thus different grades of crushed material may be produced at the same time.

In order to rock or oscillate the crushing jaws, I arrange a crank shaft, E, through the hollow core of the crushing anvil. This crank shaft is supported in suitable bearings or journals, and to rotate it, I mount on its ends pulleys *E'*, which may be connected with any convenient motive power, although other means for rotating the crank shaft may be employed, if preferred.

As shown in the drawings, the cranks of the shaft consist of eccentrics, *e*, to rotate with the shaft. I mount on these cranks or eccentrics pitmen, F, provided with wrist pins, *f*, at their upper ends. Links, G, are pivoted on the wrist pins at their inner ends and at their outer ends upon shafts, *F'*, which extend through the upper ends of the crushing jaws, although other means for pivoting them to the jaws may be adopted, if preferred. As the crank shaft rotates, the pitmen are moved up and down, and the inner ends of the links correspondingly moved. As the pitmen move

downward, they carry the inner ends of the links with them, and thus draw the upper ends of the rocking jaws toward each other, while in their upward movement they rock them back to their positions of greatest separation. As rock or ores are fed in between the initial crushing jaws, they are broken or crushed by the successive blows of the jaws as they approach during their passage through them. The material is thus crushed to the desired extent by the initial crushing surfaces when it is permitted to pass through and over upon the apex of the central crushing anvil. The material here separates, some passing to the one side and some to the other, when it is further crushed and broken between the anvil and the secondary crushing surfaces, as it passes on its way out between them. It is intended that the material shall receive, during its passage between the anvil and the secondary crushing surfaces, the desired amount of crushing or breaking, so that as it emerges it will be in the desired condition.

By adjusting the lower ends of the rocking jaws toward or from the central anvil, the degree of fineness to which the rock or ore will be crushed may be regulated, as desired, and by moving one of the jaws closer to the anvil than the other, two grades of product may be secured at the same time, one grade from one side of the anvil and the other from the other side.

As illustrated in the drawings, I have shown the rocking or oscillating crushing jaws as pivoted at the bottom, with the links by which they are rocked pivoted at the top, but it is obvious that this arrangement can be varied and reversed, as would be the case were the rocking jaws pivoted at the top and the links arranged at the bottom. I have also shown the jaws adjustable toward or from the central anvil, though it is obvious that the anvil itself could be made adjustable toward or from the jaws. I mention these as obvious variations, because I do not desire to be limited to mere details of construction, so long as the main ideas or essential features of my invention are employed. Of course it will be understood that the rocking jaws are to be arranged between the plates H at their ends to prevent the material being treated from escaping from between the jaws.

The main advantages to be derived from the use of my invention, consists in the fact that I provide two rocking or vibrating crush jaws as above described, which between them forms an initial crushing surface which first

reduces or crushes the ore or rock to a somewhat uniform condition; and the interposition of an anvil between the crushing jaws, provides two secondary crushing surfaces where the rock or ore may be further crushed to the desired degree of fineness, and which distributes the crushed stone over a greater degree of surface during their final crushing, providing a larger opening or openings for the discharge of the same, preventing any packing which might otherwise take place, as well as less destruction or obliteration of the granulated material.

In operation there might, on occasions, be a tendency for one of the crushing jaws to have greater resistance than the other, where a greater quantity of material was passing on one side of the central anvil than the other, in which case the jaw having the greatest resistance opposed to it might not be advanced toward the central anvil to as great an extent as the other. To provide for such contingency, I would suggest that the pin, *f*, be confined in a stationary guide, which I have not considered it necessary to show, that would cause such pin to move up and down in a vertical plane, thus causing each of the jaws to be drawn in the up and down movements of the pitman to the same extent toward the central anvil, thus securing the complete crushing of the material when a greater quantity was on one side of the anvil than on the other.

What I regard as new, and desire to secure by Letters Patent, is—

1. In a rock or ore breaker, the combination of two oppositely-vibrating crushing jaws the upper working surfaces of which form an initial crusher, an anvil interposed between the lower working surfaces of said jaws and forming in connection therewith two secondary crushers and discharge openings, and means for vibrating the crushing jaws, substantially as described.

2. In a rock or ore breaker, the combination of two oppositely-vibrating crushing jaws the upper working surfaces of which form an initial crusher, an anvil interposed between the lower working surfaces of such jaws and forming in connection therewith two secondary crushers and discharge openings, means for adjusting the crushing jaws with relation to each other and the anvil, and means for vibrating the crushing jaws, substantially as described.

RYERSON D. GATES.

Witnesses:

THOS. F. SHERIDAN,
SAMUEL E. HIBBEN.