

(No Model.)

G. F. OEHRL.  
FIRE ESCAPE.

No. 439,976.

Patented Nov. 4, 1890.

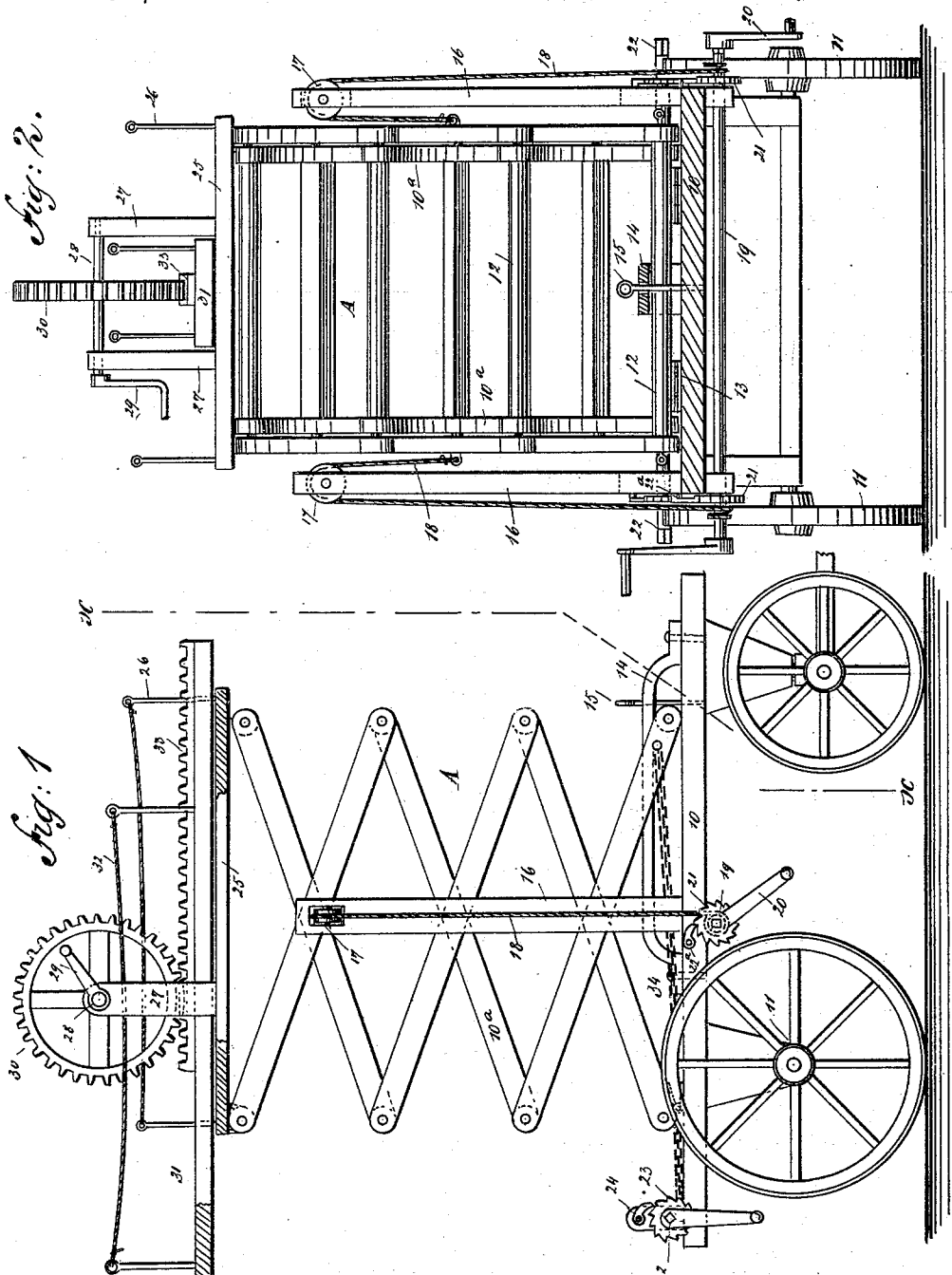

*Fig. 1*

*Fig. 2*

WITNESSES:

*Chas. Nida.*  
*C. Sedgwick*

INVENTOR:

*G. F. Oehrl*

BY

*Munn & Co*

ATTORNEYS

# UNITED STATES PATENT OFFICE.

GEORGE F. OEHL, OF MONONGAHELA CITY, PENNSYLVANIA.

## FIRE-ESCAPE.

SPECIFICATION forming part of Letters Patent No. 439,976, dated November 4, 1890.

Application filed April 1, 1890. Serial No. 346,158. (No model.)

*To all whom it may concern:*

Be it known that I, GEORGE F. OEHL, of Monongahela City, in the county of Washington and State of Pennsylvania, have invented a new and useful Improvement in Fire-Escapes, of which the following is a full, clear, and exact description.

My invention relates to an improvement in fire-escapes, and has for its object to provide a portable device which when brought to a building may be elevated expeditiously and conveniently to any desired height; and a further object of the invention is to provide in connection with the escape a bridge or gangway and means whereby the said bridge or gangway may be projected outward from the escape to the window or to the roof of a burning building and withdrawn therefrom at will.

The invention consists in the novel construction and combination of the several parts, as will be hereinafter fully set forth, and pointed out in the claims.

Reference is to be had to the accompanying drawings, forming a part of this specification, in which similar letters and figures of reference indicate corresponding parts in both the views.

Figure 1 is a side elevation of the device, partly in section; and Fig. 2 is a partial end view in section on line *x x* of Fig. 1.

Upon the body 10 of any suitable form of truck 11 the extensible body A of the escape is attached. This extensible body consists of two side pieces 10<sup>a</sup>, constructed in the form of lazy-tongs, the said sides being connected at their pivotal point by suitable cross-bars or rungs 12.

The extensible body A is secured to the bed of the truck at its rear lower end only, the attachment being usually effected through the medium of hinges 13, the opposite lower end of the body being capable of sliding upon the truck-bed to or from the hinged end, and in order that the movable end of the body may be guided upon the truck-bed a yoke-like strap 14 is longitudinally secured to the said bed, beneath which strap the bar or rung 12, connecting the sides at their front lower end, is free to pass, and when the body is elevated in the manner hereinafter described the hoisting mechanism is relieved from strain by

passing a pin 15 downward through any of a series of apertures formed in the yoke to a contact with the connecting bar or rung of the body sliding beneath said yoke. From the upper central side portions of the yoke standards 16 are upwardly projected, one standard being located at each side of the body, as shown in Fig. 2. These standards may be of any suitable height, and are provided at or near their upper ends with a pulley 17.

About centrally between the top and bottom of the body—the central pivotal point of the side lazy-tongs section of the body—one end of ropes or chains 18 is secured, one chain or rope being provided for each side of the body, and the said chains or ropes are carried over the friction-pulleys of the standards 16 and downward to an attachment with a shaft 19, journaled in suitable bearings beneath the truck-bed, which shaft is usually provided at each end with a crank-arm 20 and a ratchet-wheel 21, the ratchet-wheels of the shaft being engaged by pawls 22<sup>a</sup>, pivoted upon the sides of the truck-bed.

At one end of the truck-bed, at the top of the same, a transverse shaft 22 is journaled, which shaft is squared at its ends to receive cranks, and in turning this latter shaft the cranks located upon the shaft 19 may be employed, as the said cranks are removable from this latter shaft. The shaft 22 is also provided at or near its end with a ratchet-wheel 23, engaged by a pawl 24.

A platform 25 is secured to the upper portion of the body in any suitable or approved manner, and the said platform is ordinarily provided with a railing 26. Near the front end of the platform, at each side of the center of the same, an upright 27 is attached, and in the upper ends of said upright a shaft 28 is journaled adapted to be revolved by a crank 29, or in any other suitable manner, which shaft between the uprights is provided with an attached pinion 30. In connection with the platform a bridge or gangway 31 is employed of greater length than the platform and of sufficient width only to pass between the uprights 27. This gang-plank or bridge is also provided with a railing 32, of any approved construction, upon each side thereof, and upon its upper face with an attached lon-

itudinal rack 33, with which rack the pinion 30 is adapted to engage.

In operation the device is brought as near to a building as possible, and the body is elevated sufficiently to admit of the bridge being projected from the platform outward to an engagement with a window-sill, or with the roof, or with any portion of the building where the people may be assembled. In raising the body the shaft 19 is first revolved, as the rope or chain 18, connected with said shaft, draws directly from the center of the same, and when the body has been elevated some little distance the shaft 22 is revolved, which shaft is connected by ropes or chains 34 with the lower rung or connecting-bar at the lower front end of the body, or with the lower members of the side lazy-tongs sections at that point, and as the said shaft 22 is revolved the free lower end of the body is drawn in the direction of the hinged or fixed end, and the lazy-tongs side sections are thereby contracted and the platform elevated. When the platform has been carried up to a sufficient height, the shaft 28 is revolved, and the pinion 30, meshing with the rack 33 of the bridge or gangway 31, will cause said bridge or gangway to slide upon the platform outward in the direction of the building. The bridge or gangway is projected outward until its outer end rests upon the window-sill or other ledge of the building, and the said bridge is made sufficiently long to enable the inner end at the same time to have a bearing upon the platform of the escape. The assembled persons may by means of the bridge readily pass over to the platform of the escape, and when a sufficient number have assembled thereon the body is slowly lowered until it reaches its lowest position, and may descend to the ground by means of a ladder or equivalent device.

Having thus described my invention, I claim as new, and desire to secure by Letters Patent—

1. In a fire-escape, the combination, with the bed of a truck or similar portable structure, of an extensible body constructed of side-connected lazy-tongs sections attached at one lower end only to the bed, a platform attached to the upper end of the body, a shaft journaled in bearings upon said platform and provided with a pinion, and a bridge held to slide upon the platform, having an attached rack capable of engagement with the pinion, substantially as shown and described, and for the purpose specified.

2. In a fire-escape, the combination, with a truck-bed or other portable structure, of an extensible body-frame consisting of side-con-

nected lazy-tongs sections, one lower end of which body-frame only is attached to the truck-bed, a platform secured to the upper end of the body-frame, an apertured guide-yoke extending over the lower rung of the lower free end of the body-frame, a pin passed through the apertures of the yoke to a contact with the said lower rung, and means, substantially as shown and described, for elevating the lazy-tongs body-frame, substantially as and for the purpose specified.

3. In a fire-escape, the combination, with the bed of a truck or equivalent portable support, a lazy-tongs frame secured at one lower end to the said bed, a yoke projected over the lower rung or connecting-bar of the lower free end of the frame, and a pin adapted to pass through said yoke and in connection with the said lower bar, of a platform secured to the upper portion of the lazy-tongs frame, a shaft journaled beneath the bed, standards projected upward from the bed at each side of the frame and provided with pulleys, ropes attached to the shaft and passed over the pulleys of the standards to a connection with the sides of the frame, a second shaft journaled upon the bed near one end, and chains connecting the said shaft with the lower movable end of the frame, substantially as shown and described.

4. In a fire-escape, the combination, with the bed of a truck or other portable support, a lazy-tongs frame secured at one lower end to the said bed, a yoke projected over the lower rung or connecting-bar of the lower free end of the frame, and a pin adapted to be passed through said yoke in connection with the said lower bar, of a platform secured to the upper portion of the lazy-tongs frame, a shaft journaled beneath the bed, standards projected upward from the bed at each side of the frame and provided with pulleys, ropes attached to the shaft and passed over the pulleys of the standards to a connection with the sides of the frame, a second shaft journaled upon the bed near one end, chains connecting the said shaft with the lower movable end of the frame, standards secured to the platform of the frame, a shaft journaled in said standards, a pinion attached to the shaft, and a bridge held to slide upon the platform between the standards thereon and provided with a rack adapted for engagement with the said pinion, substantially as shown and described.

GEORGE F. OEHL.

Witnesses:

ERNEST E. HELMS,  
THOS. J. MINEHART.