

June 19, 1923.

1,459,016

R. A. CUSHING

PORTABLE POWER WASHING MACHINE ADAPTABLE TO SET TUBS

Original Filed Dec. 15, 1919

2 Sheets-Sheet 1

*Fig. 1.*

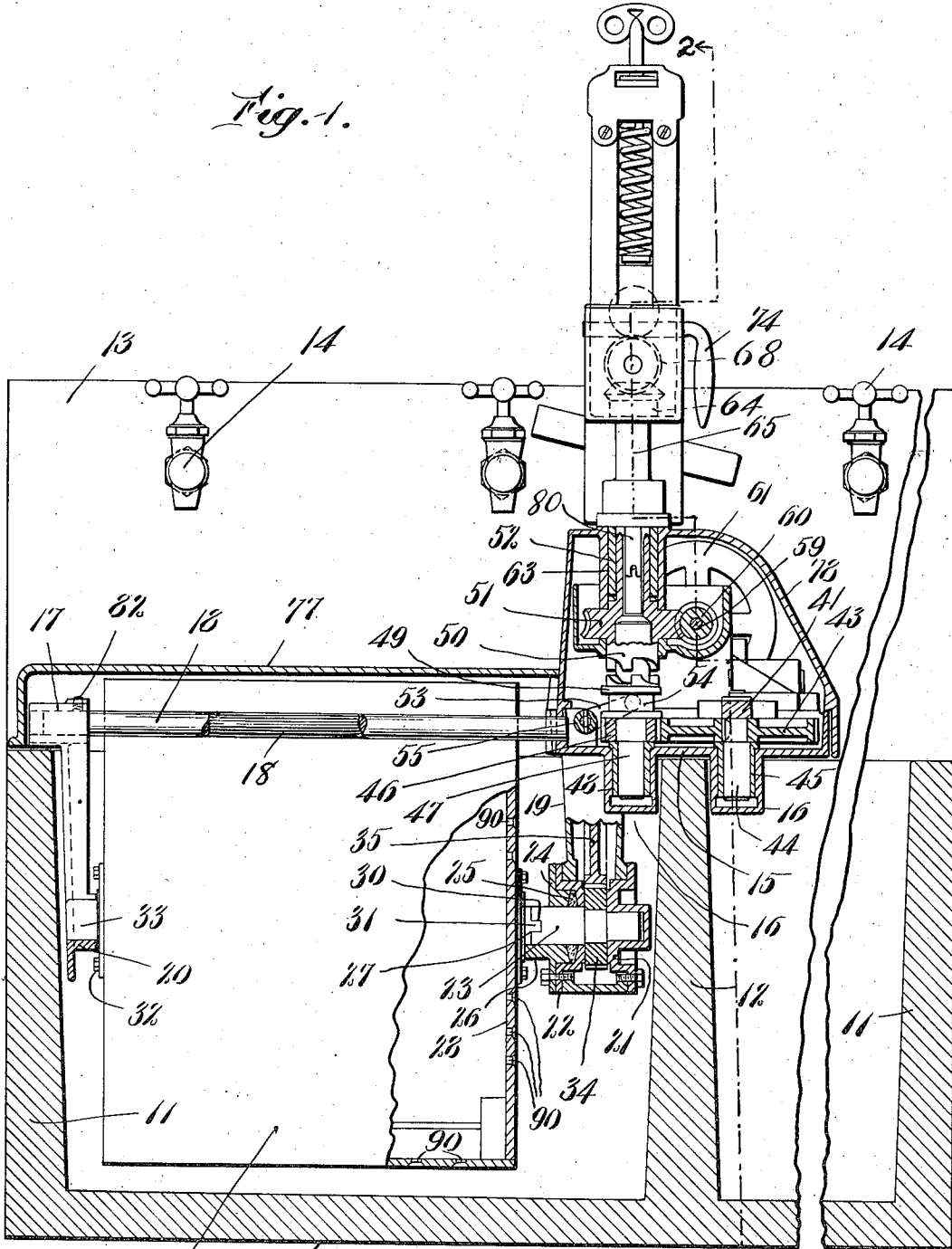

*Inventor*  
*Ralph A. Cushing*  
*by James R. Hodder*  
*att'y.*

June 19, 1923.

1,459,016

R. A. CUSHING

PORTABLE POWER WASHING MACHINE ADAPTIBLE TO SET TUBS

Original Filed Dec. 15, 1919

2 Sheets-Sheet 2

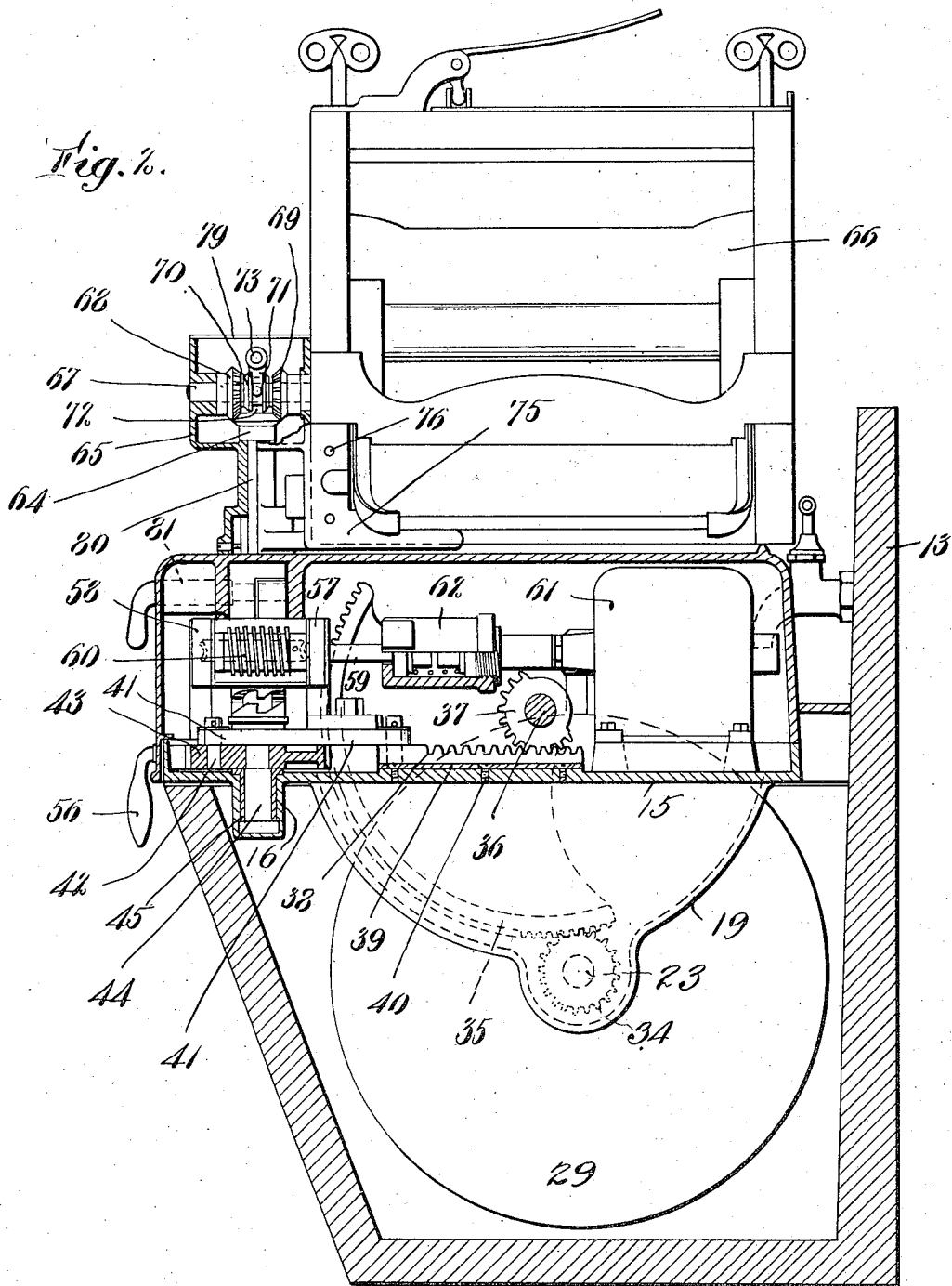

*Inventor*  
*Ralph A. Cushing*  
*by James R. Hodges*  
*att'y.*

# UNITED STATES PATENT OFFICE.

RALPH A. CUSHING, OF BROCKTON, MASSACHUSETTS.

## PORTABLE POWER WASHING MACHINE ADAPTABLE TO SET TUBS.

Application filed December 15, 1919, Serial No. 344,961. Renewed May 12, 1922. Serial No. 560,448.

*To all whom it may concern:*

Be it known that I, RALPH A. CUSHING, a citizen of the United States, and resident of Brockton, in the county of Plymouth and State of Massachusetts, have invented an Improvement in Portable Power Washing Machines Adaptable to Set Tubs, of which the following description, in connection with the accompanying drawings, is a specification, like letters on the drawings representing like parts.

My present invention relates to clothes washing machines, and more particularly to a portable combined washing machine and wringer adapted to be placed in operative position on the usual commercial type of soapstone, slate, cement, set tub or the like.

With a view to obviating the objectionable features of the ordinary clothes washing machine, in use at the present day, I have devised a unitary compact structure of minimum but ample size, the receptacle or clothes retainer of which is adapted to be placed in position with the usual standard sized set tub, and to be held in position therein by a frame resting on the side or end walls of the tub. Further, I have so designed my improved machine that by operating in a set tub, said tub being readily and easily filled and emptied, it avoids the lifting and carrying of water to and from the machine during the operation of filling and emptying the vessel, with the consequent wet and slippery floor. Also, by placing the supporting frame on the side or end walls of the tub, and properly positioning the machine operated wringer thereon, I am enabled to expedite the handling of the clothes, which may thus be taken directly from the receptacle or clothes container and passed through the wringer directly into the rising water in the adjacent section of the tub. After rinsing, the clothes may be passed through the wringer and into a basket or other receptacle placed on the supporting frame or on the floor. To expedite matters still further, I provide means for simultaneously operating both the washing mechanism and wringer, so that, after a batch of clothes has been washed and passed through the wringer into the rinsing tub, a second batch of clothes may be placed in the clothes container, the washing of such batch proceed, while at the same time the wringer op-

erated to wring the clothes in the rinsing tub.

An object of my invention, therefore, is an improved clothes washing and wringing machine to be used in connection with the ordinary standard size set tub.

Another object is the provision of means for simultaneously carrying on the operations of washing and wringing.

Still another object is an improved means for imparting an oscillatory movement to the clothes receptacle or vessel.

Other objects and novel features of construction and arrangements of parts will appear as the description of the invention progresses.

In the accompanying drawings illustrating the preferred embodiment of my invention,

Fig. 1 is a front elevation, partly in section, of my improved machine; and

Fig. 2 is a sectional side elevation through the driving mechanism on the line 2—2 of Fig. 1.

Referring to the drawings, 10 is the base, 11 the end members, 12 the partition wall, and 13 the combined back wall and splash board of the usual standard two-section set tub of slate, soapstone, cement or the like, permanently installed in a house or apartment, faucets 14 being provided for the hot and cold water to be used in the tub. Mounted on the partition wall 12 and on one of the end walls 11 is a frame comprising a member 15, retained in position on the partition wall 12 by depending extensions 16, and a bearing strut 17 resting on one of the end walls 11, this strut being spaced apart from the member 15 by parallelly arranged bars 18, as shown in Fig. 1, which bars are pinned to the frame member 15 and adjustably mounted in the strut 17 by the screw 82. Depending from the member 15 and integral therewith, is a combined bearing strut and casing 19, in the lower end of which is located a bearing in alignment with the bearing 20 in the lower end of the strut 17. The bearing in the lower end of the member 19 comprises bearing plates 21 and 22, providing a bearing for a stub shaft 23, a stuffing box 24 being associated with the plate 22 and in which is located oil retaining packing 25. The lower portion of the stuffing box 24 extends outwardly from the

plate 22, as designated at 26, to provide a bearing for the end of a stub shaft 27, secured to the exterior of the end wall 28 of the receptacle or vessel 29. The end of the stub shaft 23 is provided with a transverse slot 30 which cooperates with a transverse projection 31 on the end of the shaft 27, and by means of which the vessel 29 is driven from the shaft 23. In alignment with the stub shaft 27, and secured to the other end wall of the vessel 29 by bolts 32, is another stub shaft 33 which is rotatably mounted in the bearing 20. The end and circumferential walls of the receptacle 29 are provided with a plurality of perforations 90 allowing free access to the interior of the receptacle 29, of any water that may be in the set tub.

Securely mounted on the shaft 23, intermediate the ends thereof, is a spur gear 34, which meshes with and is driven by a segmental gear 35 enclosed in the hollow member 19, and secured to a shaft 36 mounted parallel to the shaft 23 in suitable bearings on the member 15. Also mounted on the shaft 36 and at one end thereof, is another segmental gear 37 which meshes with and is driven by a rack 38 slidably mounted in a bearing 39 secured to the member 15 by screws 40. Pivotally connected to one end of the rack bar 38 is one end of a connecting rod 41, the other end of which is pivotally connected to a crank pin 42 on a gear 43. This gear 43 is keyed to a shaft 44, rotatably mounted in a bearing 45 secured in one of the hollow extensions 16, and meshes with a spur gear 46 keyed to a shaft 47, rotatably mounted in a bearing 48 in the other extension 16. Rotatable with, but slidable longitudinally of, the shaft 47 is a clutch member 49, which may be moved into engagement with a cooperating clutch member 50, formed integral with the worm wheel 51, this worm wheel being rotatably mounted in a vertical bearing 52 secured to a cover 78 of the frame member 15. A forked member 53 engaging in a circumferential groove 54 in the clutch member 49, is secured to a shaft 55 rotatably mounted in bearings in the frame member 15, while secured to one end of the shaft 55 is a handle 56 by means of which the shaft 55 is rotated to move the clutch member 49 into and out of engagement with the cooperating clutch member 50.

Mounted in bearings 57 and 58 in a bracket bolted on the frame member 15, is a shaft 59 on which is securely mounted a worm 60 which meshes with and drives the worm wheel 51. This shaft 59 extends to the right, as shown in Fig. 2, and is connected to the driving shaft of the motor 61, mounted on the frame member 15, through a flexible coupling 62.

The shaft 80, is located above and is in alignment with the shaft 47 and detachably connected thereto, and is thus flexibly cou-

pled to the worm gear 51, passes through the housing 65, which is rotatably mounted by means of an extension 63 in a bearing in a cover 78, and has mounted at its upper end a bevel gear 64.

Above the bevel gear 64, is the main shaft 67 of the wringer 66, while rotatably mounted on the shaft 67 and meshing with the bevel gear 64 are two bevel gears 68 and 69, a clutch 70, rotatable with but slidable on the shaft 67, connecting said bevel gears 68 and 69 alternately at will to the shaft 67 to rotate said shaft in either direction. A forked member 71, engaging with a groove 72 in the clutch 70, is mounted on a shaft 73 operated by a handle 74. The housing 65 has an extension 75 on which the wringer 66 is secured in any desired manner, as by the screws 76. The construction just described enables me to rotate the wringer 66 through an angle of 360° on its mounting, and so to place it in any desired operating position, locking in said position by means of the locking clamp 81. By the fact that shafts 47 and 80 are detachably connected together and also by the fact that the wringer bracket 65 has an extension 63 which can rotate in bearings in the cover 78, the entire wringer, and operating mechanism therefor, may be dismounted by loosening the clamping means 81, and placed in the second or unused compartment of the set tub when not in use, thereby leaving the set tubs, with covers protecting the same, in substantially the same condition as without a washing machine in place, allowing the tub top to be used for shelf room, as is now the customary practice. This construction further provides that the wringer is kept clean and also adds a pleasing appearance to the device.

The receptacle or clothes container 29 is provided with the usual removable cover (not shown) and through the removal of which the operator is enabled to insert the clothes to be washed. The machine is devised so that the clothes container may be conveniently removed from its position in the set tub after use, but as the set tub is the most convenient storage place for it, and as the wringer may be swung into the position shown in the drawings, where it is out of the way, or removed entirely and placed in storage as before described, I have designed the cover 77 which, as shown in Fig. 1, entirely covers the receptacle 29 and supporting means therefor. As all working parts of the operating mechanism are enclosed by the members 19 and 65, cover 78, and cover 79, there is no danger of injury to the operator, and, being enclosed, the lubricating oil or grease necessary to the proper running of the mechanism, is prevented from soiling the clothes, either before or after washing.

The operation of my invention is as follows: The machine is placed in position on the set tubs, as illustrated in the drawings, and the motor 61 connected to any suitable source of power, as by connection to the lighting circuit by means of a plug and socket. The cover (not shown) of the receptacle or clothes retainer 29 is removed, the necessary amount of hot and cold water from the faucets 14 run into the set tub, washing soap or powder added, the clothes to be washed are placed in the receptacle or clothes retainer and the cover replaced. The motor, during this time, may or may not have been running. Assuming it to have been running, the handle 56 is rotated in a counter-clockwise direction, as viewed in Fig. 2, moving the clutch member 49 into engagement with the clutch member 50. Power is now transmitted from the motor 61 to the shaft 59, worm 60, worm wheel 51, clutch members 50 and 49 to shaft 47, gear 46, gear 43, connecting rod 41, rack 38, segmental gear 37, shaft 36, segmental gear 35, gear 34, shaft 23, to the clothes retainer 29. By means of the gear 43, connecting rod 41, rack 38 and segmental gear 37, an oscillatory motion is imparted to the clothes container 29, and such motion is the one that has been found to be the most desirable for this purpose. The flow of water into and out of the receptacle 29, through the perforations 90, assist the washing process. After the clothes have been washed, the handle 56 is rotated to separate the clutch members 49 and 50, which stops the movement of the clothes container 29. The cover (not shown) is now removed, exposing the washed clothes in the clothes container, the handle 74 rotated to clutch the bevel gear 69 to the wringer shaft 67 to cause a feed of the clothes through the wringer and into the rinsing water in the other compartment of the set tub. If it is desired to feed the clothes direct from the clothes container 29 to a basket or other receptacle in front of the set tubs, the wringer 66 is simply rotated on its bearing into the proper position and clamped therein, the clutch member 70 moved into position to have the rolls of the wringer rotate in the proper direction, and the clothes fed through the wringer into the basket. Assuming, however, that the clothes have been fed into the other compartment, as above described, and that a second batch of clothes has been placed in the clothes container 29, and that it is desired to wash such batch of clothes during the time that the clothes in the said other compartment are being fed into the basket.

To accomplish this, the handle 56 is rotated to connect the clutch members 49 and 50 and oscillate the clothes container 29, and the handle 74 turned to connect the wringer shaft 67 to the shaft 80 and worm gear 51. The washing and wringing operations may now take place simultaneously.

While I have described the preferred embodiment of my invention somewhat necessarily in detail, it is to be understood that I may vary the details of construction and arrangement of parts within wide limits without departing from the spirit of the invention.

My invention is further described and defined in the form of claims as follows:

1. A washing machine comprising a frame for spanning a tub and having a hollow end portion, said frame being provided with a pair of depending hangers, means for mounting the frame on the tub, a motor detachably mounted in the hollow end portion of the frame, driving mechanism from the motor also mounted in the hollow portion of the frame, and a clothes barrel journaled between the hangers and driven by said driving mechanism.

2. A portable washing machine adapted for combination with a set tub or the like, comprising a support having a hollow portion, depending arms thereon for positioning the support on a wall of the set tub, a bearing strut formed integral with the support and extending downwardly into the tub, a frame member extending from the support lengthwise of the tub, a bearing strut adjustably mounted on said member with a bearing thereon in substantial alinement with the bearing in the first named strut, a washing barrel rotatably mounted in said bearings, driving mechanism for said barrel, and power means in the hollow portion of said support for operating said driving mechanism.

3. A washing machine comprising a frame having an enlarged hollow end portion adapted to receive a motor therein, a motor detachably secured in such enlarged portion, a clothes barrel, means rotatably suspending the barrel from the frame and driving mechanism between the motor and barrel contained in the hollow portion of the frame.

In testimony whereof, I have signed my name to this specification, in the presence of two subscribing witnesses.

RALPH A. CUSHING.

Witnesses:

JAMES R. HODDER,  
HAROLD J. CLARK.