

(19)



Europäisches Patentamt

European Patent Office

Office européen des brevets



(11)

EP 0 680 920 B1

(12)

EUROPEAN PATENT SPECIFICATION

(45) Date of publication and mention
of the grant of the patent:
12.08.1998 Bulletin 1998/33

(51) Int. Cl.⁶: **B66B 11/00**

(21) Application number: **95106694.3**

(22) Date of filing: **04.05.1995**

(54) **Traction sheave elevator, hoisting unit and machine space**

Antriebsscheibenaufzug, Hebezeug und Maschinenstandort

Ascenseur à poulie de traction, ensemble de levage et emplacement machinerie

(84) Designated Contracting States:
**AT BE CH DE DK ES FR GB GR IE IT LI LU MC NL
PT SE**
Designated Extension States:
LT SI

(30) Priority: **04.05.1994 FI 942062**

(43) Date of publication of application:
08.11.1995 Bulletin 1995/45

(73) Proprietor: **KONE OY
00330 Helsinki (FI)**

(72) Inventors:
• **Hakala, Harri
SF-05830 Hyvinkää (FI)**
• **Mustalahti, Jorma
SF-05620 Hyvinkää (FI)**
• **Aulanko, Esko
SF-04230 Kerava (FI)**

(74) Representative:
**Zipse + Habersack
Wotanstrasse 64
80639 München (DE)**

(56) References cited:
EP-A- 0 631 967 **DE-U- 7 395**

EP 0 680 920 B1

Note: Within nine months from the publication of the mention of the grant of the European patent, any person may give notice to the European Patent Office of opposition to the European patent granted. Notice of opposition shall be filed in a written reasoned statement. It shall not be deemed to have been filed until the opposition fee has been paid. (Art. 99(1) European Patent Convention).

Description

The present invention relates to a traction sheave elevator as defined in the preamble of claim 1 and a hoisting unit as defined in claim 7.

One of the objectives in elevator development has been to achieve an efficient and economic space utilization. In conventional traction sheave driven elevators, the elevator machine room or other space for the drive machinery takes up a considerable part of the building space required for the elevator. The problem is not only the volume of the space required by the elevator, but also its placement in the building. There are various solutions for the placement of the machine room, but they generally involve significant restrictions as to the design of the building at least with regard to space utilization or appearance. For example, in the case of a so-called side-drive elevator with machine room below, a machine room or space is required below or beside the shaft as disclosed e.g. in FR-A 1,451,792, generally on the bottommost floor of the elevator system. Being a special space, the machine room generally increases the building costs.

EP 0 631 067 A2 which is published after the priority date of the present application discloses a flat hoisting unit which is mounted in the upper part of the elevator shaft to the wall or the sealing of the elevator shaft. In the elevator shaft wall a service hatch is provided which allows access to the control panel and machine of the hoisting unit.

To meet the need to achieve at an economic cost a reliable elevator allowing efficient space utilization and in which, irrespective of the hoisting height, the building space required for the elevator is substantially limited to the space needed by the elevator car and counterweight on their paths, including the safety distances, and the space needed to provide a passage for the hoisting ropes, and in which the problems or drawbacks described above can be avoided, a new type of traction sheave elevator is proposed as an invention. The traction sheave elevator of the invention is characterized by what is presented in the characterization part of claim 1. The hoisting unit of the invention is defined by what is presented in claim 7. Other embodiments of the invention are characterized by the features presented in the other claims.

Various advantages can be achieved by applying the invention, including the following:

- The traction sheave elevator of the invention allows an obvious space saving to be achieved in the building because no separate machine room is required.
- The elevator is cheap to install as the elevator machinery can be assembled and tested beforehand in factory.
- Applying the invention to practice requires no major changes in the design or manufacture of the eleva-

tor.

- The machinery and the instrument panel are within easy reach, so the manner of accessing the machinery for maintenance or in an emergency does not essentially differ from conventional elevators.

In the following, the invention is described in detail by the aid of one of its embodiments by referring to the attached drawings, in which

- Fig. 1 presents a diagrammatic view of a hoisting unit employed in the invention,
- Fig. 2 presents an elevator with machinery below in which the invention is applied,
- Fig. 3 presents the layout of the main components of an elevator applying the invention, projected on the cross-section of the elevator shaft, and
- Fig. 4 presents an elevator with machinery above, implemented according to the invention.

Fig. 1 presents a hoisting unit 9 for a traction sheave elevator as provided by the invention. The unit in this figure is the hoisting unit of a traction sheave elevator with machinery below, in which the hoisting ropes 3 go upwards from the traction sheave 7 of the hoisting machinery 6. In the case of an elevator with machinery above, the ropes would go downwards. The hoisting machinery 6 is fixed to the support 20 of the hoisting unit, which support 20 is preferably of a frame-like design. Mounted on the frame 20 is also an instrument panel 8, which contains the elevator control equipment and the equipment needed for the control of and supply of power to the electromotor comprised in the hoisting machinery 6. The hoisting machinery 6 is of a discoidal shape and, in relation to its diameter, relatively flat in the direction of the traction sheave shaft. The traction sheave 7 protrudes from the discoidal hoisting machinery 6 into the shaft space. Placed on the circumference of the hoisting machinery 6 is a brake 14. An elevator machinery usable as a hoisting machinery 6 is described e.g. in WO-A-95/00432. Such a machinery does not require a large machine space, so it can easily be placed in an opening in the wall or in a recess made in the wall on the side facing towards the shaft. A preferable thickness of the hoisting unit 9 is about or somewhat over ten centimetres. The traction sheave 7 is not included in this thickness. A 10 cm thick hoisting unit 9 can readily be accommodated in an ordinary elevator shaft wall because a typical wall thickness is at least about 15 cm, both in the case of a cast concrete wall and a brick wall.

Fig. 2 presents an elevator with machinery below in which the invention is applied, the hoisting unit 9 being placed beside the shaft in its lower part. The main parts of the elevator machinery 6 are mounted in a space limited in its maximum by the thickness of the wall of the

elevator shaft 17, in an opening 15 in the wall which is open towards the shaft space and closed with a door 16 from the outside to prevent illicit access to the machinery or entry into the shaft through the opening 15. On the shaft side, the opening may be provided with a safety net or glass or the like to make sure that one cannot e.g. stretch a hand into the shaft space past the equipment in the opening. In general, it is not sensible to close the machine space 15 completely from the shaft side because, regarding ventilation of the machine space 15, an advantageous solution is one in which the machine space is ventilated through the shaft. In some cases, however, closing the machine space on the shaft side may be necessary e.g. to stop the propagation of noise. In such cases the machine space 15 is closed on the shaft side except for the inlets required for power transmission to the traction sheave 7 and other purposes. In any case, the machine space 15 has a depth not exceeding the thickness of the wall of the elevator shaft 17. From the hoisting machinery 6 comprised in the hoisting unit, the traction sheave 7 moving the hoisting ropes 3 (depicted in broken lines) protrudes into the shaft 17. The figure shows the portion of the hoisting ropes passing below the car 1 over diverting pulleys 4,5 and the portion coming down from the upper part of the shaft 17 to the traction sheave.

Fig. 3 presents the layout of the main components of an elevator with machinery below, projected on the cross-section of the elevator shaft 17. The elevator car 1 moves along elevator guide rails 10 and the counterweight 2 along counterweight guide rails 11. The hoisting machinery 6 and the instrument panel 8 are placed in an opening in the wall of the elevator shaft 17. The traction sheave 7 protrudes from the hoisting machinery 6 and also from the opening 15 into the shaft 17. Diverting pulleys 12 placed in the top part of the shaft guide the passage of the hoisting ropes. One 12 of the diverting pulleys guides the hoisting ropes from the traction sheave 7 to the diverting pulley 13 on which the counterweight 2 is suspended and from which the hoisting ropes go further to a fixed rope anchorage at the top of the shaft. Another diverting pulley 12 guides the hoisting ropes from the traction sheave 7 to the diverting pulleys 4 and 5 attached to the car 1, by means of which the elevator car 1 is suspended on the hoisting ropes and from which the ropes go further to a fixed rope anchorage at the top of the shaft. In the figure, the hoisting ropes are represented by their cross-sections on the traction sheave and diverting pulleys, but otherwise the ropes are not shown. At each landing, the wall of the elevator shaft 17 is provided with a door opening 18 for the landing door. The elevator car 1 is provided with a corresponding door opening 19. If the elevator car is provided with a door, its door opening 19 is closed by the car door.

Fig. 4 presents a diagram representing an elevator with machinery above, implemented according to the invention. The hoisting unit 9 is placed beside the eleva-

tor shaft 117 in its upper part. The elevator machinery 6 is mounted in an opening 115 in the wall of the elevator shaft 117. The opening is open towards the shaft and closed with a door 116 from the outside of the shaft. From the hoisting machinery 6 comprised in the hoisting unit, the traction sheave 7 moving the hoisting ropes 103 (depicted in broken lines) protrudes into the shaft 117. The figure shows the portion of the hoisting ropes passing below the car 101 over diverting pulleys 104,105 and the portion going from the traction sheave towards the counterweight.

It is obvious to a person skilled in the art that different embodiments of the invention are not restricted to the examples described above, but that they may instead be varied within the scope of the claims presented below. For instance, the lay-out of the car and counterweight in the shaft is not a decisive question. It is also obvious to the skilled person that the drive shaft of the traction sheave can be provided with a support on the side facing the shaft as well, e.g. by using a support beam attached to the frame of the hoisting machinery. The skilled person also knows that the traction sheave comprised in an elevator machinery is frequently not a fixed part of the machinery but a component which need not be mounted on its drive shaft until during installation of the elevator.

Claims

1. Traction sheave elevator comprising an elevator car (1,101) moving along elevator guide rails (10), a counterweight (2) moving along counterweight guide rails (11), a set of hoisting ropes (3,103) on which the elevator car and counterweight are suspended in the elevator shaft (17,117), and a drive machine unit (6) driving a traction sheave (7) placed in the elevator shaft and acting on the hoisting ropes (3,103),
characterized in that the drive machine unit (6) is - in relation to its diameter - flat in the direction of the drive shaft of the traction sheave, and that a wall of the elevator shaft (17,117) contains a machine space (15,115) in which the essential parts of the drive machine unit (6) are placed.
2. Traction sheave elevator as defined in claim 1, **characterized** in that the machine space (15,115) consists of an opening in the wall of the elevator shaft (17,117), said opening being open towards the shaft and closed with a door (16,116) or access door from outside.
3. Traction sheave elevator as defined in claim 1 or 2, **characterized** in that the drive machine unit (6) is provided with an instrument panel for the motor driving the traction sheave (7), said instrument panel containing equipment (8) required for the

control of and supply of power to the elevator, the instrument panel (8) being preferably integrated with the drive machine unit (6) as a single assembly (9).

4. Traction sheave elevator as defined in any one of the preceding claims, **characterized** in that the drive machine unit (6) is placed beside the elevator shaft (17) in the lower part of the shaft.
5. Traction sheave elevator as defined in any one of claims 1-3, **characterized** in that the drive machine unit (6) is placed beside the elevator shaft (117) in the upper part of the shaft.
6. Traction sheave elevator as defined in any one of the preceding claims, **characterized** in that the machine space (15,115) is provided with a safety net or glass or other protective element placed on the side facing towards the elevator shaft (17,117).
7. Hoisting unit for a traction sheave elevator, which is in an opening of an elevator shaft wall, essentially within the thickness of the shaft wall, wherein the hoisting unit (9) comprises a discoidal drive machine unit (6) and an instrument panel (8) attached to a frame (20) of the hoisting unit (9), whereby in the thickness direction of the wall the hoisting unit (9) has a thickness not exceeding that of said wall of the elevator shaft (17,117) and that substantially only the traction sheave (7) or its drive shaft protrudes from the hoisting unit (9) into the shaft.

Patentansprüche

1. Antriebsscheibenaufzug, mit einem Aufzugkorb (1, 101), der sich entlang von Aufzug-Führungsschienen (10) bewegt, einem Gegengewicht (2), das sich entlang von Gegengewicht-Führungsschienen (11) bewegt, einem Satz Hebeseielen (3, 103), an denen der Aufzugkorb und das Gegengewicht in dem Aufzugschacht (17, 117) aufgehängt sind und einer Antriebsscheibe (7) antreibenden Antriebseinheit (6), die im Aufzugschacht angeordnet ist und auf die Hebeseielen (3, 103) einwirkt, dadurch gekennzeichnet, daß die Antriebseinheit (6) im Verhältnis zu ihrem Durchmesser in Richtung der Antriebswelle von der Antriebsscheibe eben ist, und daß eine Wand des Aufzugschachts (17, 117) einen Maschinenraum (15, 115) aufweist, in dem die wesentlichen Elemente der Antriebseinheit (6) angeordnet sind.
2. Antriebsscheibenaufzug nach Anspruch 1, dadurch gekennzeichnet, daß der Maschinenraum (15, 115) in der Wand des Aufzugschachts (17, 117) eine Öffnung aufweist und daß die Öffnung in Richtung des

Schachts geöffnet und von der Außenseite her mit einer Tür (16,116) oder Zugangstür verschlossen ist.

3. Antriebsscheibenaufzug nach Anspruch 1 oder 2, dadurch gekennzeichnet, daß die Antriebseinheit (6) eine Instrumententafel für den Motorantrieb der Antriebsscheibe (7) aufweist, daß die Instrumententafel eine Ausstattung (8) aufweist, die für die Steuerung des Aufzugs und die Zufuhr von Energie zum Aufzug erforderlich ist, daß die Instrumententafel (8) vorzugsweise mit der Antriebseinheit (6) als eine einzige Vorrichtung ausgebildet ist.
4. Antriebsscheibenaufzug nach einem der vorhergehenden Ansprüche, dadurch gekennzeichnet, daß die Antriebseinheit (6) seitlich vom Aufzugschacht (17) im unteren Bereich des Schachts angeordnet ist.
5. Antriebsscheibenaufzug nach einem der Ansprüche 1 bis 3, dadurch gekennzeichnet, daß die Antriebseinheit (6) seitlich vom Aufzugschacht (117) im oberen Bereich des Schachts angeordnet ist.
6. Antriebsscheibenaufzug nach einem der vorhergehenden Ansprüche, dadurch gekennzeichnet, daß der Maschinenraum (15, 115) ein Sicherheitsnetz oder Glas oder ein Schutzelement aufweist, das auf der dem Aufzugschacht (17, 117) zugewandten Seite angeordnet ist.
7. Hebezeug für einen Antriebsscheibenaufzug, das sich in einer Öffnung einer Aufzugschachtwand, im wesentlichen innerhalb der Dicke der Schachtwand, befindet, mit einer scheibenförmigen Antriebseinheit (6) und einer Instrumententafel (8), die an einem Rahmen (20) des Hebezeugs (9) angeordnet ist/sind, wobei in Richtung der Dicke von der Wand das Hebezeug (9) eine Dicke aufweist, die nicht über die Wanddicke des Aufzugschachts (17, 117) hinausgeht und daß im wesentlichen nur die Antriebsscheibe (7) oder deren Antriebswelle von dem Hebezeug (9) in den Schacht vorsteht.

Revendications

1. Ascenseur à poulie de traction comprenant une cabine d'ascenseur (1, 101) qui se déplace le long de rails de guidage d'ascenseur (10), un contrepoids (2) qui se déplace le long de rails de guidage de contrepoids (11), un ensemble de câbles de levage (3,103) sur lesquels la cabine d'ascenseur et le contrepoids sont suspendus dans la cage d'ascenseur (17,117) et une machine d'entraînement (6) qui entraîne une poulie de traction (7) pla-

cée dans la cage d'ascenseur et agissant sur les câbles de levage (3,103), caractérisé en ce que la machine d'entraînement (6) est, par rapport à son diamètre, plate dans la direction de l'arbre d'entraînement de la poulie de traction, et en ce qu'une paroi de la cage d'ascenseur (17,117) contient un emplacement de machinerie (15,115) dans lequel sont placées les parties essentielles de la machine d'entraînement (6).

5

10

2. Ascenseur à poulie de traction selon la revendication 1, caractérisé en ce que l'emplacement de machinerie (15,115) consiste en une ouverture ménagée dans la paroi de la cage d'ascenseur (17,117), la dite ouverture étant ouverte vers la cage et fermée par une porte (16,116) ou porte d'accès depuis l'extérieur.
3. Ascenseur à poulie de traction selon la revendication 1 ou 2, caractérisé en ce que la machine d'entraînement (6) est pourvue d'un tableau d'instruments pour le moteur entraînant la poulie de traction (7), ledit tableau d'instruments contenant un équipement (8) nécessaire à la commande et à la fourniture de puissance à l'ascenseur, le tableau d'instruments (8) étant de préférence intégré avec la machine d'entraînement (6) en un ensemble unique (9).
4. Ascenseur à poulie de traction selon l'une quelconque des revendications précédentes, caractérisé en ce que la machine d'entraînement (6) est placée à côté de la cage d'ascenseur (17), dans la partie inférieure de la cage.
5. Ascenseur à poulie de traction selon l'une quelconque des revendications 1 à 3, caractérisé en ce que la machine d'entraînement (6) est placée à côté de la cage d'ascenseur (117), dans la partie supérieure de la cage.
6. Ascenseur à poulie de traction selon l'une quelconque des revendications précédentes, caractérisé en ce que l'emplacement de machinerie (15,115) est pourvu d'un grillage ou d'une vitre de sécurité ou d'un autre élément de protection placé du côté tourné vers la cage d'ascenseur (17,117).
7. Ensemble de levage pour un ascenseur à poulie de traction, qui est logé dans une ouverture d'une paroi de la cage d'ascenseur, essentiellement dans les limites de l'épaisseur de la paroi de la cage, dans lequel l'ensemble de levage (9) comprend une machine d'entraînement de forme discoïdale (6) et un tableau d'instruments (8) fixé à un châssis (20) de l'ensemble de levage (9) de sorte que, dans la direction d'épaisseur de la paroi, l'ensemble de levage (9) a une épaisseur non supérieure à celle

15

20

25

30

35

40

45

50

55

de ladite paroi de la cage d'ascenseur (17,117) et que seulement la poulie de traction (7) ou son arbre d'entraînement fait sensiblement saillie, à partir de l'ensemble de levage (9), dans la cage.

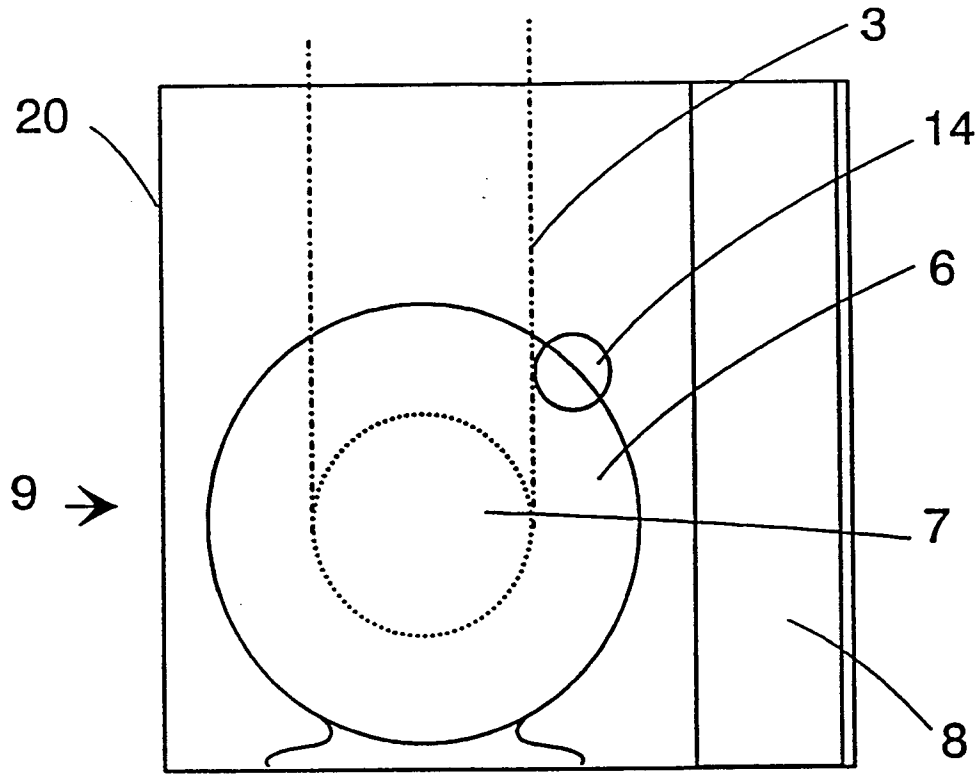

Fig. 1

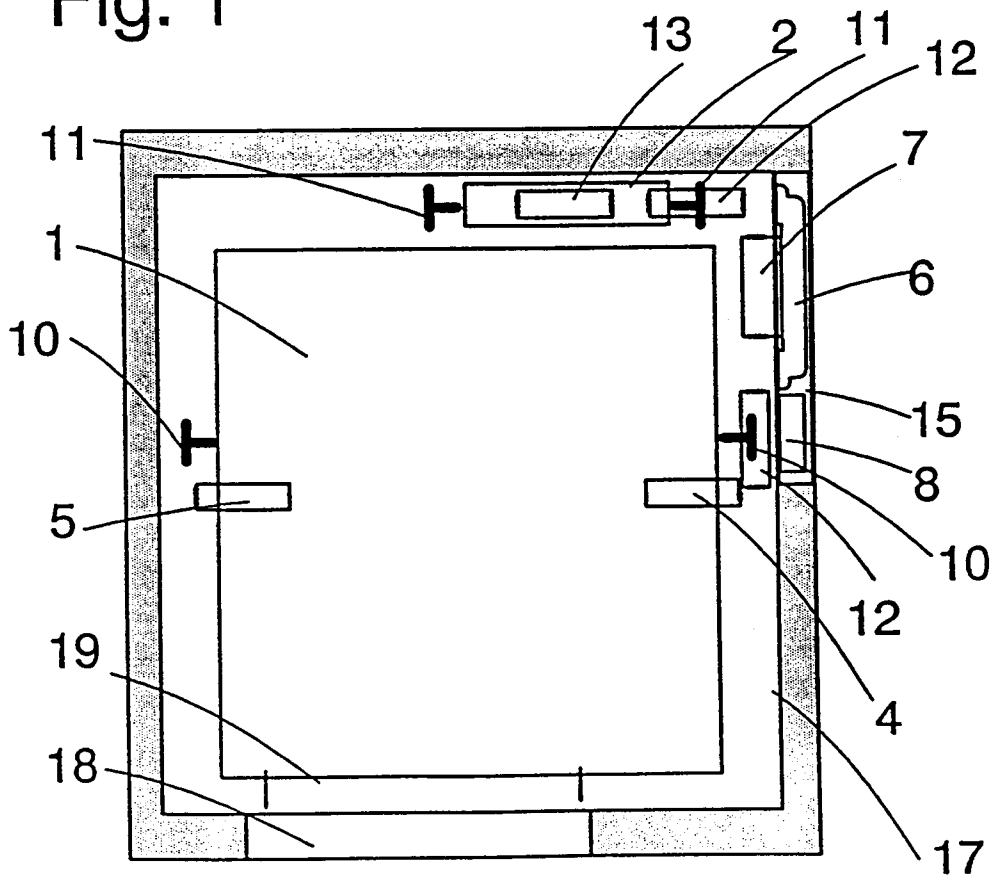

Fig. 3

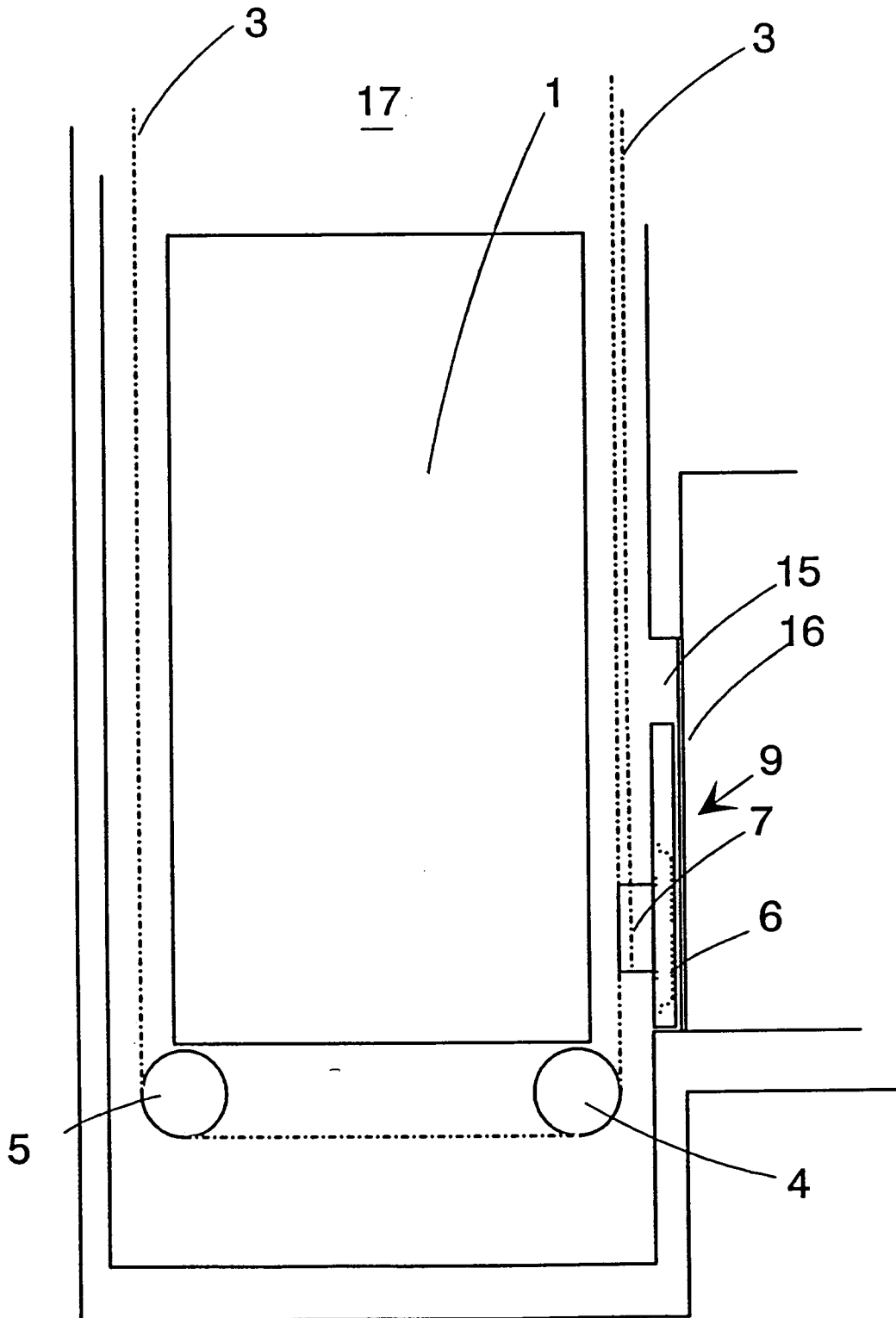

Fig. 2

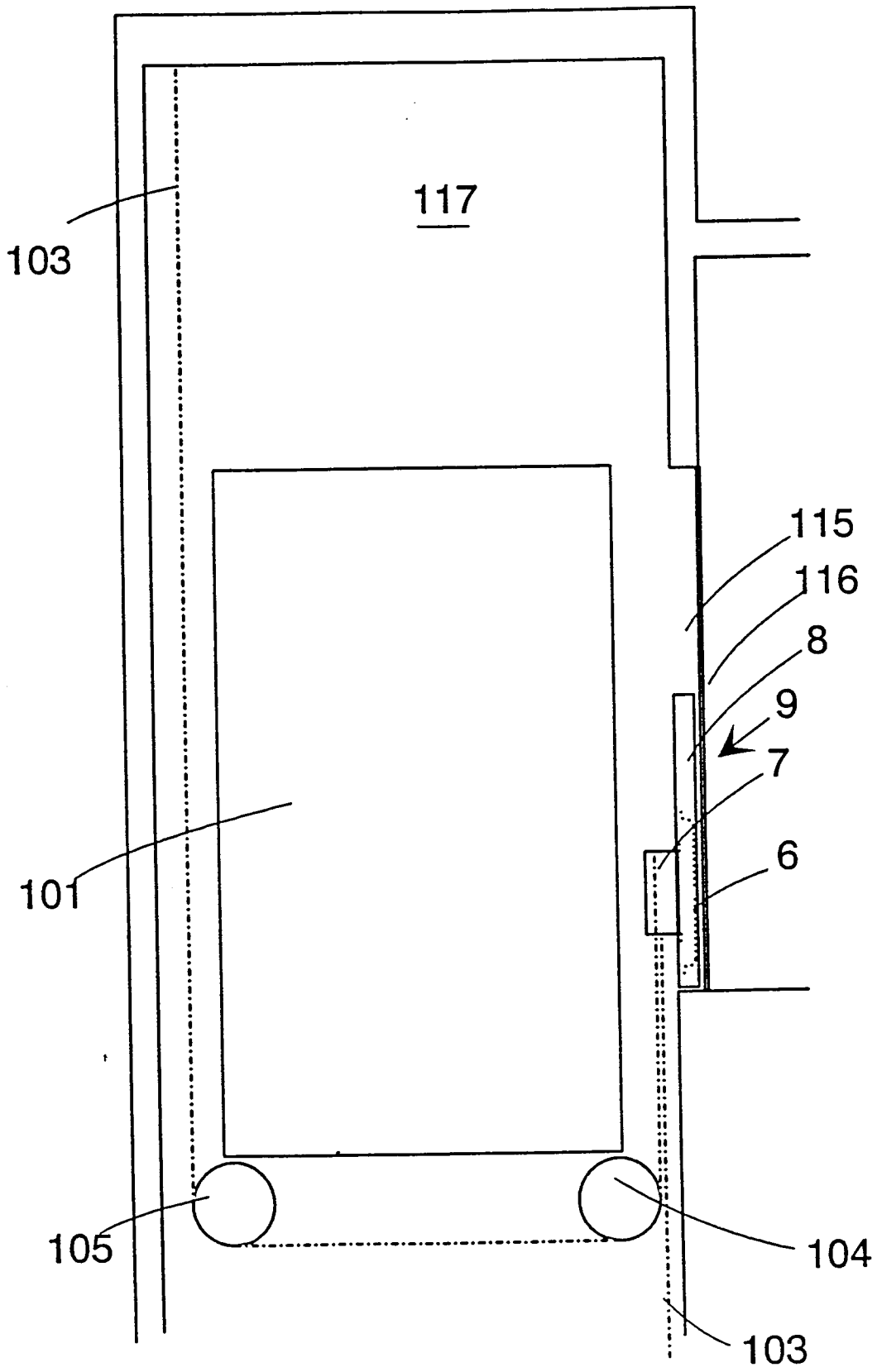

Fig. 4