

(No Model.)

2 Sheets—Sheet 1.

S. A. MILLER.
WAGON SCALE.

No. 592,809.

Patented Nov. 2, 1897.

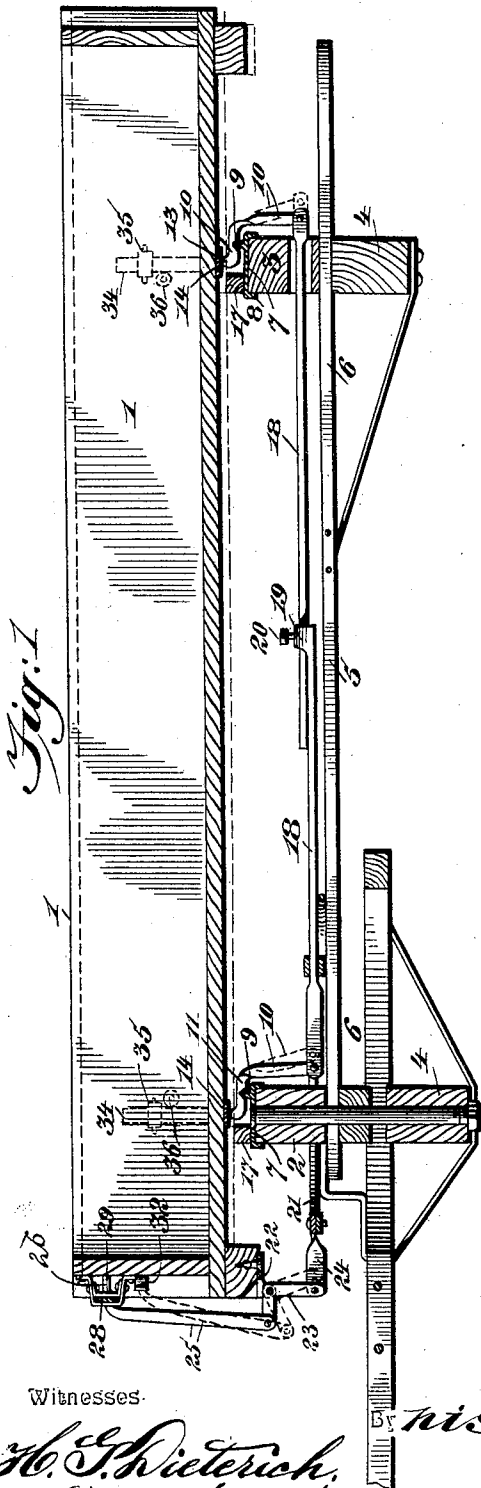

Fig. 1

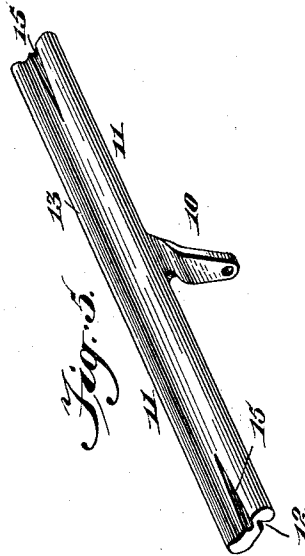

Fig. 3

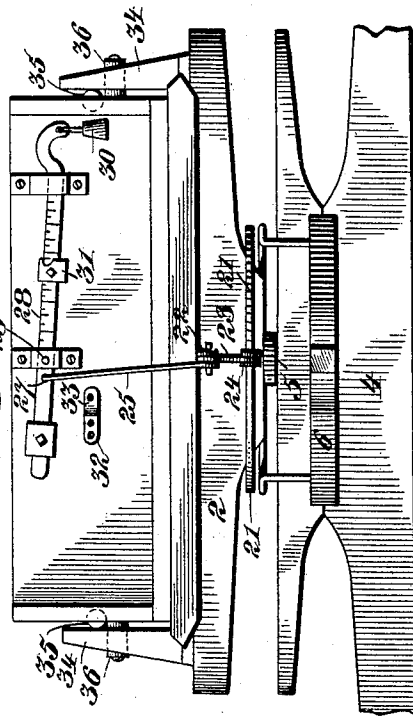

Fig. 2

Inventor

Samuel A. Miller.

By his Attorneys.

Witnesses:
J. S. Dieterich.
R. M. Smith

C. A. Snow & Co.

S. A. MILLER.
WAGON SCALE.

No. 592,809.

Patented Nov. 2, 1897.

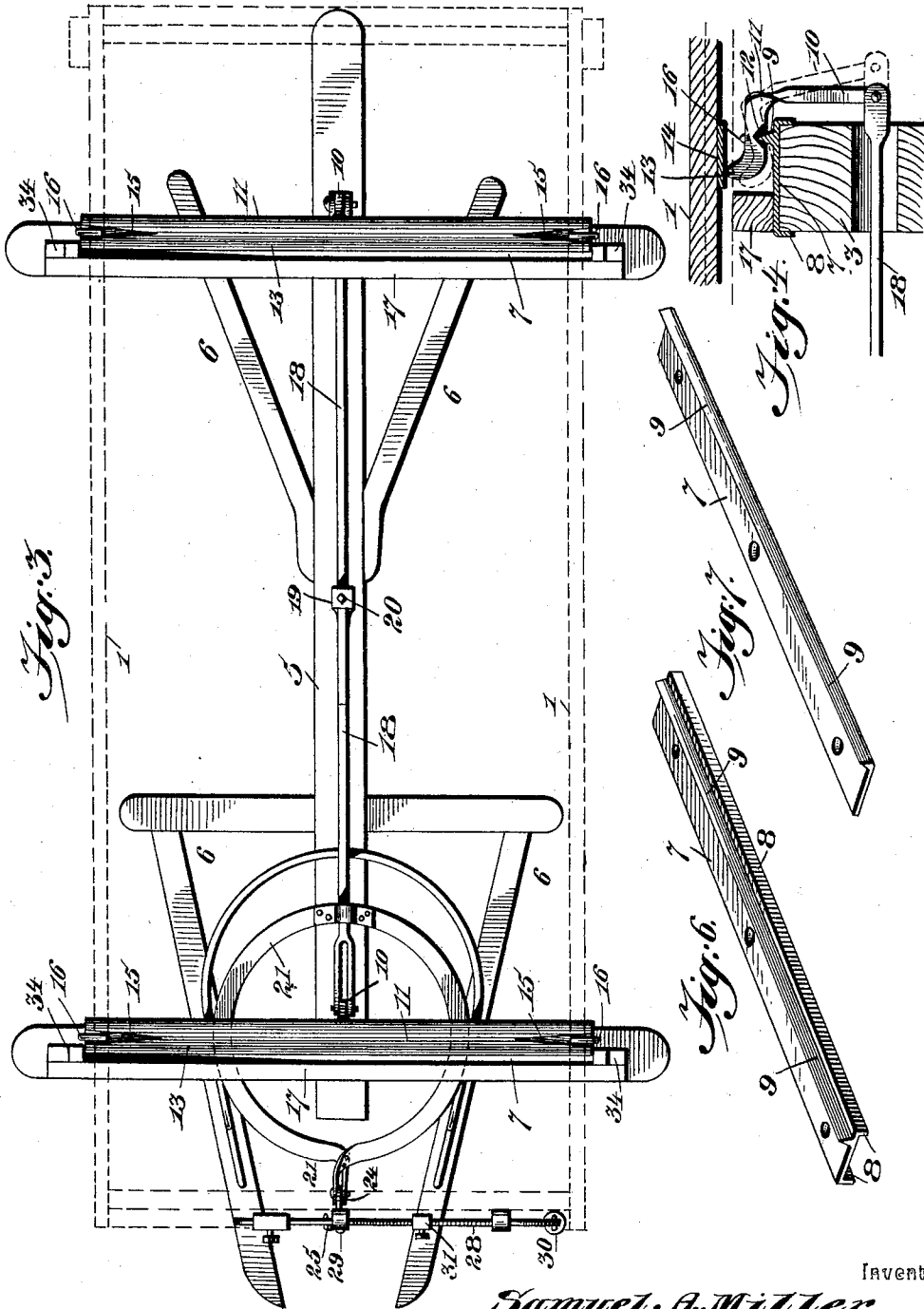

Inventor

Samuel A. Miller

Witnesses

By *his* Attorneys.

H. J. Dieterich,
R. M. Smith

C. A. Snow & Co.

UNITED STATES PATENT OFFICE.

SAMUEL A. MILLER, OF GARDNER, KANSAS.

WAGON-SCALE.

SPECIFICATION forming part of Letters Patent No. 592,809, dated November 2, 1897.

Application filed October 8, 1896. Serial No. 608,292. (No model.)

To all whom it may concern:

Be it known that I, SAMUEL A. MILLER, a citizen of the United States, residing at Gardner, in the county of Johnson and State of Kansas, have invented a new and useful Wagon-Scale, of which the following is a specification.

This invention relates to weighing-scales designed especially for use upon wagons and similar vehicles, the same being adapted to enable the exact weight of the load on the wagon to be ascertained at any point and at any time without driving the wagon upon the ordinary platform - scales. The improved scales are applied to the wagon truck and body in such manner that they can be thrown into and out of engagement with the wagon-body, so that when not in use the wagon body or box will rest entirely upon the bolsters, thus relieving the weighing apparatus from all weight, strain, and wear.

The invention consists in certain novel features and details of construction and arrangement of parts, as hereinafter fully described, illustrated in the drawings, and embodied in the claims hereto appended.

In the accompanying drawings, Figure 1 is a longitudinal section showing the improved scales applied to a wagon. Fig. 2 is a front end view of the same, showing the scale-beam. Fig. 3 is a plan view of the wagon-truck with the wagon-box removed and shown in dotted lines, also showing the weighing apparatus. Fig. 4 is an enlarged detail vertical section through the rear bolster, &c. Fig. 5 is a detail perspective view of one of the weighing-levers. Fig. 6 is a similar view of one of the fulcrum-plates. Fig. 7 is a similar view of a modified form of fulcrum-plate.

Similar numerals of reference designate corresponding parts in the several figures of the drawings.

The improved weighing apparatus contemplated in the present invention is shown as applied to an ordinary wagon, 1 designating the wagon body or box; 2, the front bolster; 3, the rear bolster; 4, the axles; 5, the reach, and 6 the hounds.

In carrying out the present invention fulcrum-plates 7 are secured to the top edges of the bolsters, and these plates are preferably constructed as shown in Fig. 6, extending the

greater part of the length of the bolsters and provided along their longitudinal edges with depending flanges 8, which embrace the sides of the bolsters and maintain the fulcrum-plates firmly thereon. Each of said plates is provided, preferably near one edge, with an upwardly-projecting knife-edge 9, forming the fulcrum-point.

If desired, the fulcrum-plate 7 may be formed as shown in Fig. 7, where it is shown to consist simply of a flat plate having one of its longitudinal edges upturned and sharpened to form a knife-edge.

Fulcrumed upon each plate 7 is an angle-lever the vertical arm 10 of which normally hangs pendent and the horizontal arm 11 of which is extended an equal distance laterally on each side of the vertical arm to provide an elongated bearing-surface for the wagon-body extending entirely across it. The horizontal arm 11 of the lever is provided on its under side with a V-shaped groove 12 to receive the knife-edge 9, and on its upper side the extremity of said arm is upturned to form a bearing edge 13, which rests under the bottom of the wagon-body and bears against a wear-plate 14, extending transversely of the bottom of the wagon-body, as shown in Figs. 1 and 4. The horizontal arm 11 of each lever is provided at each end and on its upper side with longitudinal recesses 15, into which fit loosely the inturned ends of L-shaped keepers or fingers 16, which are driven into the upper sides of the bolsters, as shown in the plan view, said keepers or fingers-preventing the displacement of the levers when relieved from the load of the wagon.

17 designates auxiliary or false bolsters resting on the fulcrum-plates 7 at one side of the knife-edge 9 and adapted to support the wagon-body when the scales are not in operation, thus relieving the scales from strain and wear while the wagon is in transit.

18 designates a longitudinally-extensible connecting-rod which is interposed between and pivotally connected to the pendent arms 10 of the levers. The rod 18 is preferably made in two sections, one section being plain and adapted to slide through an eye or loop at the end of the other section and to be held fixed by means of a binding-screw 20, thus providing for the accurate adjustment

of the levers. The connecting-rod 18 is provided at its forward end with a rigidly-attached ring or annulus 21, which extends under the front bolster and surrounds the king-bolt.

To the under side of the wagon-body at the front edge is secured a bracket 22, and upon said bracket is fulcrumed an elbow-lever 23, the pendent arm of which is connected by a link 24 with the ring 21. A rod or bar 25 connects pivotally at its lower end with the other arm of the elbow-lever 23 and extends upward, being provided at its upper end with a bend or hook 26, which is adapted to enter an opening 27 in a scale-beam 28, mounted on a fulcrum 29 on the front of the wagon-body, as shown in Fig. 2. The scale-beam is graduated and equipped with the usual weights 30 and 31, the latter being slidably mounted thereon and forming the indicator. Attached to the front of the wagon-body is a plate 32, having an opening 33 for the upper hooked end of the rod 25 when the scales are not in use.

When the weighing apparatus is not being used, the parts thereof assume the position shown in dotted lines in Fig. 1, the rod or bar 25 being engaged in the opening in the plate or keeper 32 and the wagon-body resting on the auxiliary bolsters 17. When it is desired to ascertain the weight of the load, the hooked upper end of the rod or bar 25 is engaged in the opening 27 in the scale-beam, which causes a sufficient vibration of the angle-levers to lift the wagon-body clear of the bolsters 17. By now shifting the sliding weight 31 the weight of the load may be arrived at.

The bolsters are provided with the usual spaced standards 34, between which the body 1 of the wagon is confined, and the wagon-body is provided on each side exteriorly with antifriction-rollers 35, journaled on longitudinal axes and bearing against the inner surfaces of said standards, and other rollers 36, journaled on transverse axes, so as to bear against the front and rear sides of said standards. These rollers relieve friction between the wagon-body and standards as the former moves up and down under the influence of the load while supported upon the levers of the weighing apparatus above described.

The weighing apparatus above described is simple and compact in construction, is for the greater part out of the way and not liable to injury, and will be found of great convenience and utility. The several pivots may be formed with knife-edges, and clevises or links used at the joints in order to reduce friction.

It will be understood that the several parts of the apparatus are susceptible of changes in the form, proportion, and minor details of construction which may accordingly be resorted to without departing from the spirit or sacrificing any of the advantages of this invention.

Having thus described the invention, what is claimed as new is—

1. In a weighing apparatus for wagons, &c., an angle-lever fulcrumed on the front bolster, its horizontal arm extending transversely entirely across the wagon-body to support the front end thereof, a second and similar lever fulcrumed on the rear bolster to support the rear end of the wagon-body, a horizontally-disposed rod connecting the vertical arms of said levers for simultaneously moving them, a scale-beam fulcrumed on the end of the wagon-body, an elbow-lever pivoted on the end of the wagon-body and connected at one end to the said rod, and a rod connected at one end to the other end of the elbow-lever and detachably connected at its other end to the scale-beam, substantially as described.

2. The combination with a wagon truck and body, of fulcrum-plates secured to the tops of the bolsters and having upwardly-projecting knife-edges, auxiliary bolsters supported on said plates at one side of the knife-edges, angle-levers fulcrumed on the knife-edges, the horizontal arms of said levers extending entirely across and being arranged to support the wagon-body clear of said auxiliary bolsters or to allow it to be lowered so as to rest directly thereon, a rod connecting the vertical arms of said levers, a scale-beam fulcrumed on the wagon-body, and devices to detachably connect said rod with the scale-beam, substantially as and for the purpose described.

3. The combination with a wagon truck and body, of fulcrum-plates secured to the top of the bolsters and having upwardly-projecting knife-edges, auxiliary bolsters supported on said plates at one side of the knife-edges, angle-levers fulcrumed on the knife-edges, the horizontal arms of said levers extending entirely across and being arranged to support the wagon-body clear of said auxiliary bolsters or to allow it to be lowered so as to rest directly thereon, each of said horizontal arms having a recess in its bottom face to fit over the knife-edge of its support, and also recesses at its ends above the bottom recess, keepers secured to the bolsters and adapted to loosely engage in said end recesses to prevent the accidental displacement of the levers, a rod connecting the vertical arms of said levers, a scale-beam fulcrumed on the wagon-body, and connections between said beam and rod, substantially as and for the purpose described.

4. The combination with a wagon truck and body, of levers fulcrumed on the front and rear bolsters and adapted to support the wagon-body, a connecting-rod interposed between said levers, a ring or annulus attached to said rod and extending around the king-bolt, a scale-beam fulcrumed on the wagon-body at its front end, and connections between said beam and ring, substantially as described.

5. The combination with a wagon truck and

body, of levers fulcrumed on the front and rear bolsters, a connecting-rod interposed between said levers, a ring or annulus attached to said rod and surrounding the king-bolt, an
5 elbow-lever fulcrumed at the front end of the wagon-body and having a link connection with said ring, a scale-beam on the front end of the wagon-body, and a rod or bar interposed between said elbow-lever and the scale-
10 beam, substantially as described.

6. The combination with a wagon truck and body, of levers fulcrumed on the front and rear bolsters and adapted to support the wagon-body, a connecting-rod interposed be-
15 tween said levers, a ring or annulus attached to said rod and surrounding the king-bolt, an elbow-lever fulcrumed on the front end of the wagon-body, a link connecting said ring and

elbow-lever, a scale-beam fulcrumed on the front end of the wagon-body and provided 20 with an opening, a rod or bar interposed between said elbow-lever and beam and having a bent or hooked end for engaging the opening in the beam, and a plate secured to the
25 front end of the wagon-body and provided with an opening for the hooked end of said rod or bar when the latter is disconnected from the scale-beam, substantially as described.

In testimony that I claim the foregoing as my own I have hereto affixed my signature in 30 the presence of two witnesses.

SAMUEL A. MILLER.

Witnesses:

INGA. R. PAUL,
A. F. EVANS.