

(19)



(11)

**EP 4 159 447 B1**

(12)

**EUROPEAN PATENT SPECIFICATION**

(45) Date of publication and mention of the grant of the patent:  
**09.10.2024 Bulletin 2024/41**

(51) International Patent Classification (IPC):  
**B41J 2/175<sup>(2006.01)</sup> B41J 2/01<sup>(2006.01)</sup>**

(21) Application number: **21812432.9**

(52) Cooperative Patent Classification (CPC):  
**B41J 2/1752; B41J 2/17513; B41J 2/17523;  
B41J 2/1753; B41J 2/17546; B41J 2/17553**

(22) Date of filing: **30.04.2021**

(86) International application number:  
**PCT/CN2021/091324**

(87) International publication number:  
**WO 2021/238581 (02.12.2021 Gazette 2021/48)**

**(54) INK CARTRIDGE AND PRINTING APPARATUS**

TINTENPATRONE UND DRUCKVORRICHTUNG  
CARTOUCHE D'ENCRE ET APPAREIL D'IMPRESSION

(84) Designated Contracting States:  
**AL AT BE BG CH CY CZ DE DK EE ES FI FR GB  
GR HR HU IE IS IT LI LT LU LV MC MK MT NL NO  
PL PT RO RS SE SI SK SM TR**

- **LIANG, Shichao**  
Zhuhai, Guangdong 519060 (CN)
- **ZHU, Yijing**  
Zhuhai, Guangdong 519060 (CN)
- **ZHENG, Jiezhong**  
Zhuhai, Guangdong 519060 (CN)

(30) Priority: **25.05.2020 CN 202020885920 U**  
**04.06.2020 CN 202021000434 U**  
**23.06.2020 CN 202021182775 U**  
**21.08.2020 CN 202021759045 U**  
**19.10.2020 CN 202022320862 U**  
**28.10.2020 CN 202022435691 U**

(74) Representative: **Dr. Gassner & Partner mbB**  
**Wetterkreuz 3**  
**91058 Erlangen (DE)**

(43) Date of publication of application:  
**05.04.2023 Bulletin 2023/14**

(56) References cited:  
**EP-A1- 1 424 202 CN-A- 1 419 496**  
**CN-A- 103 204 005 CN-A- 104 015 486**  
**CN-A- 108 290 416 JP-A- H07 179 004**  
**US-A1- 2003 156 160 US-A1- 2020 094 568**  
**US-B1- 6 464 339**

(73) Proprietor: **Zhuhai Ninestar Management Co., Ltd.**  
**Zhuhai, Guangdong 519000 (CN)**

(72) Inventors:  
• **CHEN, Weijian**  
**Zhuhai, Guangdong 519060 (CN)**

**EP 4 159 447 B1**

Note: Within nine months of the publication of the mention of the grant of the European patent in the European Patent Bulletin, any person may give notice to the European Patent Office of opposition to that patent, in accordance with the Implementing Regulations. Notice of opposition shall not be deemed to have been filed until the opposition fee has been paid. (Art. 99(1) European Patent Convention).

## Description

### TECHNICAL FIELD

**[0001]** The present application relates to the technical field of a printer, and in particular, to an ink cartridge and a printing apparatus.

### BACKGROUND

**[0002]** An ink cartridge is a part of an inkjet printer that is used to store printing ink and is an important component of the inkjet printer, and its quality and the mounting correctness directly affect the printing effect of the printer.

**[0003]** FIG. 1 is a schematic view showing the matching between an ink cartridge and a mounting part disposed on a printer in the prior art. Referring to FIG. 1, the mounting part 100 includes a positioning hole 110, a mounting chamber 120, an ink supply part 130 and a printer side-terminal part 140. The ink cartridge 200 includes a handle 210, a clamping part 211, an ink chamber 220, an ink outlet 230 and a chip 240, in which the clamping part 211 matches with the positioning hole 110. When the ink cartridge 200 is mounted to the mounting part 100, the clamping part 211 is clamped in the positioning hole 110, and the ink cartridge 200 may be fixed in the mounting chamber 120 of the mounting part 100 to prevent the ink cartridge 200 from detaching from the mounting part 100. At the same time, the chip 240 forms an electrical connection with the printer side-terminal part 140, the ink outlet 230 matches with the ink supply part 130 to supply the ink from the ink chamber 220 to the print head of the printer, and provide ink for a printing operation.

**[0004]** However, such a mounting method has certain disadvantages. FIG. 2 is a schematic view of a mounting offset of an ink cartridge in the prior art, referring to FIG. 2, the clamping part 211 is clamped in the positioning hole 110. Although the ink cartridge 200 can be prevented from detaching from the mounting part 100 in a Z-axis direction, the ink cartridge 200 cannot be prevented from being offset in a Y-axis direction. Specifically, the correct mounting position of the ink cartridge 200 and the mounting part 100 is the position 0, however, the ink cartridge 200 may occur an offset in the Y-axis direction, and may reach a right offset position A or a left offset position B, so that a case where the chip 240 cannot form an electrical connection with the printer side-terminal part 140 or the printer cannot identify the chip 240 of the ink cartridge 200 may occur.

**[0005]** US2020094568A1 discloses a consumables consumption apparatus including a cartridge determination section that determines one of a specified cartridge and an unspecified cartridge which is attached to the consumables consumption apparatus in accordance with maintenance subject information indicating a subject of a maintenance contract and a notification section that requests a selection of one of use agreement of the un-

specified cartridge and replacement of the unspecified cartridge by the specified cartridge when the cartridge determination section determines that the unspecified cartridge is attached and that makes a notification indicating at least one of information on cancellation of the maintenance contract and information on replacement by the specified cartridge when the use agreement is selected.

**[0006]** CN103204005A discloses a printing material supply system 10 including a printer 50 equipped with a holder 600 and cartridges 20 that are detachably attached to the holder 600. The holder 600 has a first apparatus-side locking element 810 and a lever 800. The first apparatus-side locking element 810 is formed as part of the lever 800. The cartridge 20 has a first cartridge-side locking element 210 that includes a first locking surface 211 to engage with the first apparatus-side locking element 810. The first cartridge-side locking element 210 has an extended surface 219 that prevents a negative Z-axis end 818 of the lever 800 from running on the first locking surface 211.

### SUMMARY

**[0007]** The present application is set out in the appended set of claims. The present application provides an ink cartridge and a printing apparatus, which are intended to solve technical problems caused by the offset of the ink cartridge in the prior art: a chip cannot form an electrical connection with a printer side-terminal part or a printer cannot identify the chip of the ink cartridge.

**[0008]** In order to achieve the above purposes, one aspect of the present application provides an ink cartridge for being detachably mounted in a printing apparatus, which includes a cartridge body, an ink outlet located on a first wall of the cartridge body, a chip located on a third wall intersecting with the first wall and at least one positioning part.

**[0009]** The positioning part is disposed on a side wall of the cartridge body intersecting with the third wall where the chip is disposed.

**[0010]** The positioning part has a positioning boss, and a distance from the positioning boss to the first wall of the cartridge body is less than or equal to a maximum distance from the chip to the first wall of the cartridge body, the distance from the positioning boss to the first wall of the cartridge body is greater than or equal to a minimum distance from the chip to the first wall of the cartridge body.

**[0011]** In a possible implementation, the positioning part further includes a positioning plate.

**[0012]** The positioning plate is disposed on at least one side wall that is disposed between a top surface and the first wall of the cartridge body and intersects with a side wall where the chip is located, and the positioning boss is located on the positioning plate.

**[0013]** In a possible implementation, the ink cartridge further includes an elastic arm.

**[0014]** One end of the elastic arm is connected with the positioning plate, and the other end of the elastic arm is connected with the positioning boss.

**[0015]** In a possible implementation, the cartridge body further includes: a second wall disposed opposite to the first wall and a fourth wall disposed opposite to the third wall, and a fifth wall and a sixth wall that are disposed opposite to each other, located between the first wall and the second wall, and intersect with the third wall and the fourth wall, in which the third wall and the fourth wall are located between the first wall and the second wall, and the first wall, the second wall, the third wall, the fourth wall, the fifth wall and the sixth wall enclose the cartridge body provided with an ink chamber therein.

**[0016]** The ink outlet is located on the first wall.

**[0017]** The chip is located on the third wall.

**[0018]** The positioning part is located on the fifth wall and/or the sixth wall.

**[0019]** The chip includes a plurality of terminals.

**[0020]** In a possible implementation, the plurality of the terminals are arranged in a plurality of rows, in the plurality of rows of terminals, the lowermost row of terminals are closest to the first wall, and the uppermost row of terminals are farthest from the first wall, a distance from the positioning boss to the first wall is less than or equal to a distance from the uppermost row of terminals to the first wall, the distance from the positioning boss to the first wall is greater than or equal to a distance from the lowermost row of terminals to the first wall.

**[0021]** In a possible implementation, the plurality of terminals are provided with respective contact parts connected with styluses in the printing apparatus, the contact parts are arranged in a plurality of rows, the lowermost row of contact parts are closest to the first wall, the uppermost row of contact parts are farthest from the first wall, the distance from the positioning boss to the first wall is less than or equal to a distance from the uppermost row of contact parts to the first wall, and the distance from the positioning boss to the first wall is greater than or equal to a distance from the lowermost row of contact parts to the first wall.

**[0022]** Optionally, the plurality of terminals are arranged in four rows, which sequentially are a first row, a second row, a third row and a fourth row in a direction away from the first wall. The positioning boss is disposed on a side of the first row away from the first wall, and/or the positioning boss is disposed on a side of the fourth row close to the first wall.

**[0023]** Optionally, the positioning boss is disposed on a side of the second row away from the first wall, and/or the positioning boss is disposed on a side of the third row close to the first wall.

**[0024]** In a possible implementation, the positioning part is two in number.

**[0025]** One positioning part is disposed on a side of the sixth wall close to the third wall, and the other positioning part is disposed on a side of the fifth wall close to the third wall, and the two positioning parts are disposed

opposite to each other.

**[0026]** In a possible implementation, the ink cartridge further includes a handheld part which is disposed on the third wall.

5 **[0027]** In an embodiment of the present application, there is provided an ink cartridge, including at least one positioning part disposed on a side wall of a cartridge body intersecting with a third wall where a chip is located, the positioning part has a positioning boss, a distance from the positioning boss to the first wall of the cartridge body is less than or equal to a maximum distance from the chip to the first wall of the cartridge body, and the distance from the positioning part to the first wall of the cartridge body is greater than or equal to a minimum distance from the chip to the first wall of the cartridge body. That is, the positioning boss is located within a coverage area of the chip in a vertical direction. On the one hand, such arrangement may prevent the ink cartridge from detaching from a mounting part of the printing apparatus in the vertical direction, and the ink cartridge has simple structure and is easy for mounting, and can be stably fixed in the mounting part of the printing apparatus. On the other hand, the offset of the ink cartridge, in particular, the chip in an extension direction of the side wall where the chip is located may be prevented, and a large offset error of the chip caused by the positioning boss being away from the chip may be avoided, thereby realizing the electrical connection between the chip and a printer side-terminal part better.

30 **[0028]** Another aspect of the present application provides a printing apparatus including at least two mounting plates, at least one side-terminal part and an ink supply part, the ink supply part is disposed in a mounting chamber and is configured for docking with the ink outlet.

35 **[0029]** The mounting plates are disposed on a side wall of the mounting chamber, the side-terminal part is disposed between the two mounting plates, and the two mounting plates have respective bumps toward one side of the side-terminal part, and the bumps are configured to be clamped with a positioning boss of an ink cartridge.

40 **[0030]** The side-terminal part includes a base and a plurality of styluses, the plurality of stylus are disposed on the base and are arranged in a plurality of rows, and the bumps are located between the plurality of rows of the stylus.

45 **[0031]** In embodiments of the present application, there is provided a printing apparatus including the ink cartridge as described above, the ink cartridge is mounted in the mounting chamber of the printing apparatus and at least includes a positioning part disposed on the side wall of the cartridge body intersecting with the third wall where the chip is located, the positioning part has a positioning boss, a distance from the positioning boss to a bottom surface of the cartridge body is less than or equal to a maximum distance from the chip to bottom surface of the cartridge body, a distance from the positioning part to the bottom surface of the cartridge body is greater than or equal to a minimum distance from the chip to the bot-

tom surface of the cartridge body. That is, the positioning boss is located within a coverage area of the chip in a vertical direction. On the one hand, such arrangement may prevent the ink cartridge from detaching from the mounting part of the printing apparatus in the vertical direction, and the ink cartridge has simple structure and is easy for mounting operation, and can be firmly fixed in the mounting part of the printing apparatus. On the other hand, the offset of the ink cartridge, in particular, the chip in an extension direction of the side wall where the chip is located may be prevented, and a large offset error of the chip caused by the positioning boss being far away from the chip may be avoided.

#### BRIEF DESCRIPTION OF DRAWINGS

**[0032]** In order to describe technical solutions in embodiments of the present application or in the prior art more clearly, the drawings required for use in the description of the embodiments or the prior art will be briefly described below. Obviously, the drawings in the description below are some embodiments of the present application, and other drawings may be obtained from these drawings without creative effort for those of ordinary skill in the art.

FIG. 1 is a schematic view showing the matching between an ink cartridge and a mounting part disposed on a printer in the prior art.

FIG. 2 is a schematic view showing a mounting offset of an ink cartridge in the prior art.

FIG. 3 is a structural schematic view of a mounting part of a printing apparatus according to Embodiment 1 of the present application.

FIG. 4 is a partial cross-sectional view of the mounting part of the printing apparatus according to Embodiment 1 of the present application.

FIG. 5 is a structural schematic view of an ink cartridge according to Embodiment 2 of the present application.

FIG. 6 is a partially enlarged schematic view of the ink cartridge according to Embodiment 2 of the present application.

FIG. 7 is a structural schematic view of a mounting part of another printing apparatus according to Embodiment 2 of the present application.

FIG. 8 is a partially enlarged schematic view of another ink cartridge according to Embodiment 2 of the present application.

FIG. 9 is a structural schematic view of a mounting part according to Embodiment 3 of the present application.

FIG. 10 is a partial cross-sectional structural schematic view of the mounting part in FIG. 9.

FIG. 11 is an enlarged structural schematic view of position A in FIG. 10.

FIG. 12 is a structural schematic view of a printer side-terminal part in FIG. 9.

FIG. 13 is a structural schematic view of a first ink cartridge according to Embodiment 3 of the present application.

FIG. 14 is an enlarged structural schematic view of position B in FIG. 13.

FIG. 15 is a structural schematic view showing the matching between the ink cartridge of FIG. 13 and a mounting part.

FIG. 16 is a structural schematic view of a second ink cartridge according to Embodiment 3 of the present application.

FIG. 17 is a structural schematic view showing the matching between the ink cartridge in FIG. 16 and a mounting part.

FIG. 18 is a structural schematic view of a third ink cartridge according to Embodiment 3 of the present application.

FIG. 19 is a structural schematic view of a fourth ink cartridge according to Embodiment 3 of the present application.

FIG. 20 is a partial structural schematic view of another mounting part according to Embodiment 3 of the present application.

FIG. 21 is a partial structural schematic view of a fifth ink cartridge according to Embodiment 3 of the present application.

FIG. 22 is a structural schematic view of a sixth ink cartridge according to Embodiment 3 of the present application.

FIG. 23 is a structural schematic view of a mounting part according to Embodiment 4 of the present application.

FIG. 24 is a structural schematic view of a printer terminal part in FIG. 23.

FIG. 25 is a schematic view of a stylus in an ink cartridge according to Embodiment 4 of the present application.

FIG. 26 is a structural schematic view of an ink cartridge according to Embodiment 4 of the present application.

FIG. 27 is an enlarged view of position A in FIG. 26. FIG. 28 is a schematic view of a chip in an ink cartridge according to Embodiment 4 of the present application.

FIG. 29 is an enlarged view of an engaging part in an ink cartridge according to Embodiment 4 of the present application.

FIG. 30 is a cross-sectional view showing a matching between the ink cartridge and the mounting part according to Embodiment 4 of the present application.

FIG. 31 is a cross-sectional view showing another matching between the ink cartridge and the mounting part according to Embodiment 4 of the present application.

FIG. 32 is a schematic view of an ink cartridge according to Embodiment 5 of the present application.

FIG. 33 is a schematic view of an ink cartridge according to Embodiment 6 of the present application.

FIG. 34 is a schematic view of an ink cartridge according to Embodiment 7 of the present application.

Reference numerals:

**[0033]**

30-mounting part; 30a-bottom wall; 30b-opening; 30c-first side wall; 30d-second side wall; 30e-third side wall; 30f-fourth side wall; 31-first mounting position; 311-first opposing surface; 312-second opposing surface; 32-second mounting position; 321-third opposing surface; 322-fourth opposing surface; 33-third mounting position; 331-fifth opposing surface; 332-sixth opposing surface; 320-mounting chamber; 330-ink supply part; 34-fourth mounting position; 341-seventh opposing surface; 342-eighth opposing surface; 35-mounting plate; 3501-locking surface; 3502-groove; 3503-guiding surface; 3504-first side surface; 3505-inner opposing surface; 351-first bump; 352-second bump; 353-third bump; 354-fourth bump; 355-fifth bump; 356-sixth bump; 357-seventh bump; 358-eighth bump; 3601-first printer side-terminal part; 3602-second printer side-terminal part; 3603-third printer side-terminal part; 3604-fourth printer side-terminal part; 361-base; 362-stylus; 362a-first portion; 362b-second portion; 362c-third portion; 363-slot; 364-first protrusion; 3641-lower surface of first protrusion; 3642-front surface of first protrusion; 3643-first surface; 365-second protrusion; 3651-lower surface of second protrusion; 3652-front surface of second protrusion; 3653-second surface; 39d-fourth groove; 39e-fifth groove; 40-ink cartridge; 40a-first wall; 40b-second wall; 40c-third wall; 40c1-mounting surface; 40d-fourth wall; 40e-fifth wall; 40f-sixth wall; 420-cartridge body; 421-ink capsule; 422-adapter; 423-engaging part; 4231-vertical surface; 4232-transition surface; 4233-horizontal surface; 424-protruding part; 430-ink outlet; 431-ink outlet hole; 440-chip; 4401-substrate; 4402-recess part; 4403-through hole; 4404-concave part; 4405-notch; 4406-bulging part; 4407-clamping part; 4408-contact part; 441-left mounting detection terminal; 442-reset terminal; 443-clock terminal; 444-right mounting detection terminal; 445-left high voltage terminal; 446-power supply terminal; 447-ground terminal; 448-data terminal; 449-right high voltage terminal; 442a-left extension terminal; 443a-right extension terminal; 450-positioning part; 4501-top surface; 4502-side surface; 4503-end surface; 4504-extension wall; 451-first positioning boss; 452-second positioning boss; 460-anti-jamming part; 461-anti-slip stripe; 470-handle; 471-first clamping part; 480-second clamping part.

**DESCRIPTION OF EMBODIMENTS**

**[0034]** Embodiment 3 to Embodiment 8 are not accord-

ing to the present application and are present for illustration purposes only.

**[0035]** In order to make the purposes, technical solutions and advantages of the present application clearer, the technical solutions of the present application will be clearly and completely described below with reference to the drawings in the present application. Obviously, the described embodiments are some but not all of the embodiments of the present application. Based on the embodiments of the present application, all other embodiments obtained by those of ordinary skill in the art without creative effort shall fall within the scope claimed by the present application.

**[0036]** The basic working principle of an inkjet printer lies in producing small ink droplets first, and then using an inkjet head to guide small ink droplets to the set position, the smaller the ink droplets, the clearer printed pictures. The basic principle seems simple, but it is not easy to operate, just like the principle of calculus, it is not complicated, but how to use it is complicated.

**[0037]** The inkjet printer includes an ink cartridge, which is a part used in inkjet printer for storing printing ink, and is an important component of the inkjet printer; and the ink cartridge directly affects the printing effect of the printer in terms of its quality and mounting correctness. However, in the prior art, the mounting deviation of ink cartridge often occurs, such that a chip on the ink cartridge cannot be normally electrically connected to a printer side-terminal part, or even the printer cannot recognize the chip on the ink cartridge.

**[0038]** In view of the above, on one hand, the ink cartridge and the printing apparatus disposed in the present application can prevent the ink cartridge from detaching from the mounting part of the printing apparatus in a vertical direction, and has the advantages of simple structure and easiness for mounting, and the ink cartridge can be firmly fixed in the mounting part of the printing apparatus. On the other hand, the ink cartridge and the printing apparatus disposed in the present application can prevent the ink cartridge, especially the chip, from being offset in an extension direction of a side wall on which the chip is located, and avoid a case where the large chip offset error is caused by a positioning boss being away from the chip.

Embodiment 1

**[0039]** FIG. 3 is a structural schematic view of a mounting part of a printing apparatus according to Embodiment 1 of the present application, and FIG. 4 is a partial cross-sectional view of a mounting part of a printing apparatus according to Embodiment 1 of the present application.

**[0040]** Referring to FIG. 3 and FIG. 4, a printing apparatus according to an embodiment of the present application, for example, a printer, has a mounting part 30 capable of mounting and fixing an ink cartridge. The mounting part 30 may accommodate one or more ink cartridges, and if the mounting part 30 accommodates a

plurality of ink cartridges, the plurality of ink cartridges may be ink cartridges of different colors. As shown in FIG. 3, the mounting part 30 may accommodate four ink cartridges, which may be one kind of ink cartridge with the same color (e.g., black) or four kinds of ink cartridges with different colors (e.g., black, red, yellow and blue). The mounting part 30 is a component having an opening 30b and having a substantially cuboid shape. The mounting part 30 has a bottom wall 30a, the opening 30b, a first side wall 30c, a second side wall 30d, a third side wall 30e and a fourth side wall 30f. The mounting part 30 has a mounting chamber 320, and the mounting part 30 includes at least two mounting plates 35, at least one printer side-terminal part, and an ink supply part 330. The printer side-terminal part is disposed between two mounting plates 35. The bottom wall 30a is disposed opposite to the opening 30b, the first side wall 30c is disposed opposite to the second side wall 30d, and the third side wall 30e is disposed opposite to the fourth side wall 30f. The bottom wall 30a, the first side wall 30c, the second side wall 30d, the third side wall 30e and the fourth side wall 30f enclose the mounting chamber 320 for accommodating the ink cartridge 40. The ink supply part 330 is disposed on the bottom wall 30a of the mounting chamber 320, and the printer side-terminal part is disposed on the first side wall 30c. Three-dimensional rectangular coordinate system, XYZ coordinate system is established. X, Y and Z axes are perpendicular to each other. A direction of the bottom wall 30a pointing to the opening 30b refers to a +Z-axis direction, a direction of the second side wall 30d pointing to the first side wall 30c refers to a +X-axis direction, and a direction of the third side wall 30e pointing to the fourth side wall 30f refers to a +Y-axis direction. Exemplarily, a plurality of printer side-terminal parts and a plurality of mounting plates 35 are disposed on the first side wall 30c. The plurality of mounting plates 35 are used for fixing the plurality of printer side-terminal parts to the first side wall 30c, and spacing the plurality of printer side-terminal parts from each other to avoid occurrence of a short circuit between two printer side-terminal parts. **[0041]** Exemplarily, as shown in FIG. 3 and FIG. 4, the mounting part 30 may be mounted with four ink cartridges 40 and have four mounting positions, which are a first mounting position 31, a second mounting position 32, a third mounting position 33 and a fourth mounting position 34, respectively. Respective mounting positions have corresponding printer side-terminal parts, which are a first printer side-terminal part 3601, a second printer side-terminal part 3602, a third printer side-terminal part 3603, and a fourth printer side-terminal part 3604, respectively; and the printer side-terminal parts are spaced apart by the mounting plates 35. The first printer side-terminal part 3601 of the first mounting position 31 is mounted between two mounting plates 35, which have a first opposing surface 311 and a second opposing surface 312, respectively. The first opposing surface 311 is located on a -Y-axis direction side of the first printer side-terminal part 3601, and the second opposing surface 312 is located

on a +Y-axis direction side of the first printer side-terminal part 3601. The second printer side-terminal part 3602 of the second mounting position 32 is mounted between two mounting plates 35, which have a third opposing surface 321 and a fourth opposing surface 322, respectively. The third opposing surface 321 is located on a -Y-axis direction side of the second printer side-terminal part 3602, and the fourth opposing surface 322 is positioned on a +Y-axis direction side of the second printer side-terminal part 3602. The third printer side-terminal part 3603 of the third mounting position 33 is mounted between two mounting plates 35, which have a fifth opposing surface 331 and a sixth opposing surface 332, respectively. The fifth opposing surface 331 is located on a -Y-axis direction side of the third printer side-terminal part 3603, and the sixth opposing surface 332 is located on a +Y-axis direction side of the third printer side-terminal part 3603. The fourth printer side-terminal part 3604 of the fourth mounting position 34 is mounted between two mounting plates 35, which have a seventh opposing surface 341 and an eighth opposing surface 342, respectively. The seventh opposing surface 341 is located on a -Y-axis direction side of the fourth printer side-terminal part 3604, and the eighth opposing surface 342 is located on a +Y-axis direction side of the fourth printer side-terminal part 3604.

**[0042]** Some of the printer side-terminal parts are omitted in FIG. 4 to facilitate observation. The structures of the printer side-terminal parts are the same. Specifically, as shown in FIG. 3 and FIG. 4, a first bump 351, a second bump 352, a third bump 353, a fourth bump 354, a fifth bump 355, a sixth bump 356, a seventh bump 357 and an eighth bump 358 are disposed in the mounting part 30. The first bump 351 and the second bump 352 are disposed in the first mounting position 31. The third bump 353 and the fourth bump 354 are disposed in the second mounting position 32. The fifth bump 355 and the sixth bump 356 are disposed in the third mounting position 33. The seventh bump 357 and the eighth bump 358 are disposed in the fourth mounting position 34. The first mounting position 31 is taken as an example for illustration. The first bump 351 is disposed on the first opposing surface 311, and is a bump that protrudes from the first opposing surface 311 toward the inside of the first mounting position 31. That is, the first bump 351 is a bump that protrudes from the first opposing surface 311 toward the +Y-axis direction side. The second bump 352 is disposed on the second opposing surface 312, and is a bump that protrudes from the second opposing surface 312 toward the inside of the first mounting position 31. That is, the second bump 352 is a bump that protrudes from the second opposing surface 312 toward the -Y-axis direction side. In the Z-axis direction, the first bump 351 and the second bump 352 are located at the same height and disposed opposite to each other. The printer side-terminal part includes a base and a plurality of styluses disposed on the base, the plurality of styluses are arranged in a plurality of rows, and the bumps are located between

the plurality of rows of styluses. For example, in the Z-axis direction, the plurality of the styluses are staggered in two rows. As shown in FIG. 4, the first printer side-terminal part 3601 has nine styluses, and the nine styluses are arranged in two columns in the +Z-axis direction, namely, the first column R1 and the second column R2. In the Z-axis direction, the first bump 351 and the second bump 352 are located between the first column R1 and the second column R2. That is, the first bump 351 and the second bump 352 are on a +Z-axis direction side of the first column R1, and the first bump 351 and the second bump 352 are on a -Z-axis direction side of the second column R2. It is easy to understand that such arrangement makes the positioning of the chip on the ink cartridge more accurate.

**[0043]** The structures and positions of the third bump 353, the fifth bump 355 and the seventh bump 357 in their respective mounting positions are the same as those of the first bump 351, which will not be described repeatedly. The structures and positions of the fourth bump 354, the sixth bump 356 and the eighth bump 358 in their respective mounting positions are the same as those of the second bump 352, which will not be described repeatedly.

**[0044]** FIG. 7 is a structural schematic view of a mounting part of a printing apparatus according to an embodiment of the present application. A bottom groove may also be disposed in the mounting plate 35. Specifically, a first groove, a second groove, a third groove, a fourth groove 39d and a fifth groove 39e are sequentially disposed on the mounting plates 35. Taking the fourth mounting position as an example, only the fourth groove 39d and the fifth groove 39e are shown in FIG. 7. The fourth groove 39d and the fifth groove 39e are disposed on the mounting plates 35. The fourth groove 39d and the fifth groove 39e are disposed on the -Y-axis side and the +Y-axis side of the fourth printer side-terminal part 3604, respectively. The sixth bump 356 and the seventh bump 357 are respectively disposed on the left and right sides of the fourth groove 39d. Specifically, the sixth bump 356 is disposed on a -Y-axis side of the fourth groove 39d, the seventh bump 357 is disposed on a +Y-axis side of the fourth groove 39d, and the eighth bump is disposed on a -Y-axis side of the fifth groove 39e. The first groove, the second groove, the third groove, the fourth groove 39d and the fifth groove 39e are all in an inverted U shape, and the first bump 351 to the eighth bump 358 are all located in shoulder positions of the grooves, respectively.

**[0045]** When the ink cartridge 40 is mounted in the mounting part 30, the first positioning boss engages with the seventh bump 357, and the second positioning boss engages with the eighth bump 358, thereby preventing the ink cartridge 40 from being offset in the Y-axis direction and preventing the ink cartridge 40 from being detached from the mounting part 30. This structure is simple, the mounting operation is easy, and the ink cartridge can be firmly fixed in the mounting part 30. At the same

time, the ink cartridge 40, in particular the chip 440, is prevented from being offset in the Y-axis direction. The electrical connection between the chip 440 and the printer side-terminal part is better realized.

## Embodiment 2

**[0046]** FIG. 5 is a structural schematic view of an ink cartridge according to an embodiment of the present application, and FIG. 6 is a partially enlarged schematic view of an ink cartridge according to an embodiment of the present application.

**[0047]** Referring to FIG. 5 and FIG. 6, coordinate system directions in the two figures are the same as the coordinate system directions of the mounting part 30 when the ink cartridge 40 is mounted to the mounting part 30. The ink cartridge according to an embodiment of the present application has a first wall 40a, a second wall 40b, a third wall 40c, a fourth wall 40d, a fifth wall 40e and a sixth wall 40f. When the ink cartridge 40 is mounted to the mounting part 30, the first wall 40a, the second wall 40b, the third wall 40c, the fourth wall 40d, the fifth wall 40e and the sixth wall 40f correspond to the bottom wall 30a, the opening 30b, the first side wall 30c, the second side wall 30d, the third side wall 30e and the fourth side wall 30f of the mounting part 30, respectively. The ink cartridge 40 includes a cartridge body 420, an ink outlet 430, and a chip 440. The first wall 40a and the second wall 40b are disposed opposite to each other in the Z-axis direction, the third wall 40c and the fourth wall 40d are disposed opposite to each other in the X-axis direction, the fifth wall 40e and the sixth wall 40f are disposed opposite to each other in the Y-axis direction, the third wall 40c and the fourth wall 40d are substantially perpendicular to the first wall 40a and the second wall 40b, and the fifth wall 40e and the sixth wall 40f are substantially perpendicular to the first wall 40a, the second wall 40b, the third wall 40c, and the fourth wall 40d. The first wall 40a is on a -Z-axis direction side of the second wall 40b, the third wall 40c is on a +X-axis direction side of the fourth wall 40d, and the fifth wall 40e is on a -Y-axis direction side of the sixth wall 40f. The first wall 40a, the second wall 40b, the third wall 40c, the fourth wall 40d, the fifth wall 40e and the sixth wall 40f enclose a cartridge body 420 having an ink chamber therein. The ink outlet 430 is disposed on the first wall 40a, and the chip 440 is disposed on the third wall 40c.

**[0048]** The ink cartridge 40 further includes at least one positioning part 450 disposed on the fifth wall 40e or the sixth wall 40f, and the positioning part 450 has a positioning boss, exemplarily, the positioning part has a second positioning boss 452. A distance from the second positioning boss 452 to the first wall 40a of the cartridge body 420 is less than or equal to the maximum distance from the chip 440 to the first wall 40a of the cartridge body 420, and the distance from the second positioning boss 452 to the first wall 40a of the cartridge body 420 is greater than or equal to the minimum distance from

the chip 440 to the first wall 40a of the cartridge body 420. That is, in the Z-axis direction, the positioning boss is disposed within the range of a coverage area of the chip 440 in the Z-axis direction. When the ink cartridge 40 is mounted to the mounting part 30, the second positioning boss 452 is clamped with a corresponding one of the first bump 351 to the eighth bump 358 to prevent the ink cartridge 40 from being detached from the mounting part 30. In this structure, the positioning boss 452 is close to the chip 440. On one hand, the ink cartridge can be prevented from detaching from the mounting part of the printing apparatus in the vertical direction, the structure is simple, the mounting operation is easy, and the ink cartridge can be firmly fixed in the mounting part of the printing apparatus. On the other hand, the ink cartridge, especially the chip, can be prevented from being offset in the extension direction of the side wall on which the chip is located, and a large offset error of the chip caused by the positioning boss being away from the chip is avoided. The ink cartridge 40 is mounted to the mounting part 30 in the -Z-axis direction, and when it is required to take the ink cartridge 40 out of the mounting part 30, the ink cartridge 40 is detached from the mounting part 30 in the +Z-axis direction.

**[0049]** As shown in FIG. 5, when facing the third wall 40c, a line, parallel to the Y-axis, of the lowermost end (an end on the -Z-axis side) of the chip 440 is a first line D1, and a line, parallel to the Y-axis, of the uppermost end (an end on +Z-axis side) of the chip 440 is a second line D2, and an area between the first line D1 and the second line D2 is a coverage area T of the chip 440 in the Z-axis direction. The positioning boss 452 is disposed within the range of the coverage area T of the chip 440 in the Z-axis direction. Distance A from the positioning boss 452 to the first wall 40a of the cartridge body 420 is less than or equal to the maximum distance B2 from the chip 440 to the first wall 40a of the cartridge body 420, and the distance A from the positioning boss 452 to a bottom surface of the cartridge body 420 is greater than or equal to the minimum distance B 1 from the chip 440 to the bottom surface of the cartridge body 420. Specifically, the maximum distance B2 is a distance from the uppermost end of the chip 440 to the first wall 40a, and the minimum distance B 1 is a distance from the lowermost end of the chip 440 to the first wall 40a.

**[0050]** In a possible implementation, the chip 440 includes a plurality of terminals arranged in a plurality of rows, where the terminals in the lowermost row is closest to the first wall 40a, and the terminals in the uppermost row is farthest from the first wall 40a. The distance A from the second positioning boss 452 to the first wall 40a is less than or equal to a distance B2 from the terminals in the uppermost row to the first wall 40a, and the distance A from the second positioning boss 452 to the first wall 40a is greater than or equal to a distance B 1 from the terminals in the lowermost row to the first wall 40a. Exemplarily, in the Z-axis direction, the positioning bosses are between a plurality of rows of terminals. When the

ink cartridge 40 is mounted to the mounting part 30, the positioning boss is clamped with a corresponding one of the first bump 351 to the eighth bump 358 to prevent the ink cartridge 40 from being detached from the mounting part 30.

**[0051]** The plurality of terminals are provided with contact parts connected with the styluses in the printing apparatus. The contact parts are arranged in a plurality of rows, where the contact parts in the lowermost row are closest to the first wall 40a, and the contact parts in the uppermost row are farthest from the first wall 40a. The distance from the second positioning boss 452 to the first wall 40a is less than or equal to a distance from the contact parts in the uppermost row to the first wall 40a, and the distance from the second positioning boss 452 to the first wall 40a is greater than or equal to a distance from the contact parts in the lowermost row to the first wall 40a.

**[0052]** The chip 440 includes a plurality of terminals. Exemplarily, as shown in FIG. 6, the chip 440 includes nine terminals.

**[0053]** The chip 440 has first terminals, second terminals, third terminals and extension terminals. Specifically, the first terminals are respectively a reset terminal 442, a clock terminal 443, a power supply terminal 446, a ground terminal 447 and a data terminal 448. Further, some of the first terminals are connected to a memory of the chip 440, which is generally disposed on the back of the chip and is not shown in the figure. The second terminals are respectively a left high voltage terminal 445 and a right high voltage terminal 449; the third terminals are respectively a left mounting detection terminal 441 and a right mounting detection terminal 444; and the extension terminals are respectively a left extension terminal 442a and a right extension terminal 443a.

**[0054]** In a possible implementation, the plurality of terminals are arranged in four rows, sequentially arranged in a direction away from the first wall 40a as a first row, a second row, a third row and a fourth row. As shown in FIG. 6, specifically, the chip 440 has notches, which are respectively located at the left and right ends of the chip 440. The nine terminals of the chip 440 are arranged in four rows. The first terminals, the second terminals and the third terminals are arranged in four rows in the mounting direction, where the first row L1, the second row L2, the third row L3, and the fourth row L4 are sequentially arranged in the +Z-axis direction. Further, a part of the first terminals (specifically, the power supply terminal 446, the ground terminal 447 and the data terminal 448) are located in the first row L 1; the second terminals are located in the second row L2; the other part of the first terminals (specifically, the reset terminal 442 and the clock terminal 443) are located in the third row L3; the third terminals are located in the fourth row L4. The extension terminals are disposed in the third row L3, and are disposed in the same row as the other part of the first terminals (specifically, the reset terminal 442 and the clock terminal 443).

**[0055]** Specifically, in this embodiment, the left exten-

sion terminal 442a is connected to the reset terminal 442 through a left fine-line connection part, and the right extension terminal 443a is connected to the clock terminal 443 through a right fine-line connection part. The left extension terminal 442a may be connected to any one of the reset terminal 442, the clock terminal 443, the power supply terminal 446, the ground terminal 447 and the data terminal 448; and the right extension terminal 443a is connected to any one of the reset terminal 442, the clock terminal 443, the power supply terminal 446, the ground terminal 447 and the data terminal 448.

**[0056]** The second positioning boss 452 is disposed on a side of the terminals in the first row away from the first wall 40a, and/or, the second positioning boss 452 is disposed on a side of the terminals in the fourth row near the first wall 40a. Further, the second positioning boss 452 is disposed on a side of the terminals in the second row away from the first wall 40a, and/or, the second positioning boss 452 is disposed on a side of the terminals in the third row near the first wall 40a. In the Z-axis direction, the positioning boss is disposed between the first row L1 and the fourth row L4. Further, in the Z-axis direction, the positioning boss is disposed between the second row L2 and the third row L3. Specifically, the positioning boss is disposed on the +Z-axis direction side of the first row L1 and/or the second row L2, and the positioning boss is disposed on the -Z-axis direction side of the third row L3 and/or the fourth row L4. In this structure, the positioning of the chip 440, in particular the terminals, is more accurate (especially the position in the Y-axis direction), thereby avoiding that the terminals cannot be well electrically connected to the printer side-terminal part.

**[0057]** Optionally, there may be only one positioning part, or there may be two or more positioning parts. As shown in FIG. 5 and FIG. 6, the positioning part in this embodiment includes a first positioning boss 451 (obscured by the chip 440 in FIG. 5) and the second positioning boss 452. The first positioning boss 451 is disposed on the fifth wall 40e, and the second positioning boss 452 is disposed on the sixth wall 40f. The first positioning boss 451 is a boss that is formed by protruding from the fifth wall 40e towards the -Y-axis direction, and the second positioning boss 452 is a boss that is formed by protruding from the sixth wall 40f towards the +Y-axis direction. In the Z-axis direction, the first positioning boss 451 and the second positioning boss 452 are located at the same position and are disposed opposite to each other. The first positioning boss 451 is disposed in the -Y-axis direction of the chip 440, and the second positioning boss 452 is disposed in the +Y-axis direction of the chip 440. In the Z-axis direction, the first positioning boss 451 and the second positioning boss 452 are disposed on the +Z-axis direction side of the first row L1 and the second row L2, and the first positioning boss 451 and the second positioning boss 452 are disposed on a -Z-axis direction side of the third row L3 and the fourth row L4. When the ink cartridge 40 is mounted to the

mounting part 30, the first positioning boss 451 and the second positioning boss 452 are clamped with the corresponding bumps from the first bumps 351 to the eighth bumps 358 to prevent the ink cartridge 40 from being detached from the mounting part 30. In this structure, the first positioning boss 451 and the second positioning boss 452 are disposed on the +Z-axis direction side of the first row L1 and the second row L2, and on the -Z-axis direction side of the third row L3 and the fourth row L4, so that the first positioning boss 451 and the second positioning boss 452 are more accurate for positioning the chip 440 (especially the position in the Y-axis direction), thereby avoiding the terminals cannot be well electrically connected with the printer side-terminal part.

**[0058]** When the ink cartridge 40 is mounted to the mounting part 30, the first positioning boss 451 and the second positioning boss 452 are clamped with the corresponding bumps to prevent the ink cartridge 40 from detaching from the mounting part 30. In this way, the ink cartridge has a simple structure and is easy for mounting, the ink cartridge 40 can be firmly fixed in the mounting part 30, and the chip 440 can be accurately electrically connected with the printer side-terminal part. Specifically, taking the mounting of the ink cartridge 40 to the first mounting position 31 as an example, the order in which the ink cartridge 40 is mounted to the mounting part 30: A. the ink cartridge 40 moves from the opening 30b of the mounting part 30 to the bottom wall 30a in the -Z-axis direction. B. the first positioning boss 451 contacts with the first opposing surface 311 in the mounting part 30, and the second positioning boss 452 contacts with the second opposing surface 312 in the mounting part 30, and the ink cartridge 40 begins to be guided. C. the ink cartridge 40 continues to move down, and the first positioning boss 451 and the second positioning boss 452 reach the positions of the first bump 351 and the second bump 352 respectively. D. the ink cartridge 40 continues to move in the -Z-axis direction, the +Z-axis side of the first positioning boss 451 abuts against the -Z-axis side of the first bump 351, and the +Z-axis side of the second positioning boss 452 abuts against the -Z-axis side of the second bump 352, and the ink cartridge 40 is mounted in place. E. at this time, the chip 440 is electrically connected with the first printer side-terminal part 3601, and the ink outlet 430 matches with the ink supply part 330.

**[0059]** Specifically, in a process of mounting the ink cartridge 40 to the mounting part 30, the first positioning boss 451 contacts with the first opposing surface 311 in the mounting part 30, and the second positioning boss 452 contacts with the second opposing surface 312 in the mounting part 30, thereby guiding the ink cartridge 40. In the process of mounting the ink cartridge 40, the first opposing surface 311 and the second opposing surface 312 function to guide the ink cartridge 40 to prevent the ink cartridge 40 from being offset in the Y-axis direction. A case in which the ink cartridge 40 cannot be accurately mounted to the mounting part 30 is effectively avoided. The processes and clamping positions and ef-

facts of mounting the ink cartridge 40 to other mounting positions are the same, which will be not described repeatedly.

**[0060]** When there is a printing need in the printer, the ink in the ink chamber may reach the print head along the ink outlet 430 and the ink supply part 330, and then the printing operation is completed.

**[0061]** The first positioning boss 451 engages with the first bump 351 and the second positioning boss 452 engages with the second bump 352, which prevents the offset of the ink cartridge 40 in the Y-axis direction. The first positioning boss 451 and the second positioning boss 452 are disposed within the range of the coverage area T of the chip 440 in the Z-axis direction. In this structure, the first positioning boss 451 and the second positioning boss 452 are close to the chip 440. On the one hand, the ink cartridge can be prevented from being detached from the mounting part of the printing apparatus in the vertical direction, the structure is simple, the mounting operation is easy, and the ink cartridge can be firmly fixed in the mounting part of the printing apparatus; on the other hand, the ink cartridge, especially the chip, may be prevented from an offset in the extension direction of the side wall where the chip is located, and it is avoided that a case where large offset error of the chip is caused by the positioning boss away from the chip.

**[0062]** The first positioning boss 451 and the second positioning boss 452 are disposed on the +Z-axis direction side of the first row L1 and/or the second row L2, and on the -Z-axis direction side of the third row L3 and/or the fourth row L4, so that the first positioning boss 451 and the second positioning boss 452 are more accurate for positioning the chip 440, in particular the terminals (especially the position in the Y-axis direction), thereby avoiding that the terminals cannot be well electrically connected to the printer side-terminal part.

**[0063]** Optionally, an elastic member may be added on the -X-axis side of the ink cartridge, which can make the ink cartridge have a certain moving space in the X-axis direction, and can ensure that the ink cartridge 40 can be better fixed to the mounting part 30. The elastic member may be a movable member, a spring, silicone, rubber and other elastic materials with a certain distance from the body of the ink cartridge 40.

**[0064]** A handheld part may also be added at an upper position of the first wall 40a or the third wall 40c to facilitate a user to exert force by the hand when the user takes out the ink cartridge 40. The handheld part may be an anti-slip stripe 461 (as shown in FIG. 5) that increases friction, a movable member with a certain distance from the body of ink cartridge 40, or a bulge fixed on the body of ink cartridge and the like. The ink supply part 330 may be an ink supply needle or an ink supply tube.

**[0065]** Adding a movable handle on the -X-axis side of the ink cartridge, may make the ink cartridge have a certain moving space in the X-axis direction, and may ensure that the ink cartridge 40 may be better fixed to the mounting part 30.

**[0066]** The first positioning boss 451 and the second positioning boss 452 on the ink cartridge 40 may be bulges which are injection molded and integrated with the ink cartridge; it may also be that the first positioning boss 451 and the second positioning boss 452 are arranged on a replaceable part, so that the same structure can match with a variety of different ink cartridge structures; the first positioning boss 451 and the second positioning boss 452 may also be bulging parts mounted on the third wall 40c by means of separate sticking, clamping, etc. In addition, they may also be elastic bulging parts mounted on the third wall 40c by means of sticking, clamping, interference fit, etc., and the elastic bulging parts may be made of silicone, rubber, cork or other materials.

**[0067]** FIG. 8 is an enlarged schematic view of another ink cartridge according to the embodiment of the present application.

**[0068]** Referring to FIG. 8, at least one positioning part is disposed on the fifth wall 40e or the sixth wall 40f. Specifically, the at least one positioning part further includes a positioning plate which is disposed on the fifth wall 40e or the sixth wall 40f. For example, a first positioning plate 45a extends in the +X-axis direction from a junction position of the fifth wall 40e and the third wall 40c, and a second positioning plate 45b extends in the +X-axis direction from a junction position of the sixth wall 40f and the third wall 40c. The positioning bosses are located on the positioning plate and are disposed within the coverage area T of the chip 440 in the Z-axis direction.

**[0069]** The chip 440 includes a plurality of terminals which are arranged in a plurality of rows, and the positioning bosses are located between the plurality of rows in the Z-axis direction.

**[0070]** In a possible implementation, the positioning part further includes an elastic arm, where one end of the elastic arm is connected with the positioning plate, and the other end of the elastic arm is connected with the positioning boss. Exemplarily, as shown in FIG. 8, one end of a first elastic arm 45A is connected with the first positioning plate 45a, and the other end of the first elastic arm 45A is connected with the first positioning boss 451; and, one end of a second elastic arm 45B is connected with the second positioning plate 45b, and the other end of the second elastic arm 45B is connected with the second positioning boss 452.

**[0071]** The first elastic arm 45A and the second elastic arm 45B are elastic. In this embodiment, the first elastic arm 45A and the second elastic arm 45B are elastic, and the first positioning boss 451 and the second positioning boss 452 are disposed at -Z-axis ends of the first elastic arm 45A and the second elastic arm 45B, respectively. The first positioning boss 451 is a bump which is formed by protruding from the first elastic arm 45A toward the -Y-axis direction, and the second positioning boss 452 is a bump which is formed by protruding from the second elastic arm 45B toward the +Y-axis direction. Taking mounting of the ink cartridge 40 to the first mounting position as an example, when the ink cartridge 40 is mount-

ed to the mounting part 30, the first positioning boss 451 engages with the first bump 351, and the second positioning boss 452 engages with the second bump 352, thereby preventing the offset of the ink cartridge 40 in the Y-axis direction, and preventing the ink cartridge 40 from detaching from the mounting part 30. The first elastic arm 45A and the second elastic arm 45B are at least partially elastic, and the first positioning boss 451 and the second positioning boss 452 are disposed at the -Z-axis ends of the first elastic arm 45A and the second elastic arm 45B of extension walls. This structure enables the ink cartridge 40 to be mounted more smoothly without getting stuck. When the ink cartridge 40 is taken out from the mounting part 30, it is more convenient, and the user uses less force when taking out the ink cartridge 40.

**[0072]** Of course, shapes of the first positioning boss 451 and the second positioning boss 452 may be different. For example, the +Z-axis side of the first positioning boss 451 is an inclined downward plane, and the +Z-axis side of the second positioning boss 452 is a horizontal surface. When the ink cartridge 40 is mounted in the mounting part 30, the inclined downward plane is engaged with the first bump 351, and the horizontal surface engages with the second bump 352. This structure makes the ink cartridge 40 more firmly engage with the mounting part 30. In this way, the shapes of the two positioning parts are different, which can make the ink cartridges have a certain floating space, without getting stuck. Here, shapes of the positioning bosses are not specifically limited.

### Embodiment 3

**[0073]** In the prior art, the mounting part of the printer includes a hole, a mounting chamber, an ink supply part and a printer side-terminal part. The ink cartridge includes a handle, an ink chamber, an ink outlet and a chip. The handle of the ink cartridge is provided with a clamping portion to match with the hole. When the ink cartridge is mounted to the mounting part, the clamping portion enters into and is clamped with the hole, thereby fixing the ink cartridge into the mounting chamber of the mounting part and preventing the ink cartridge from detaching from the mounting part. At the same time, the chip is electrically connected with a printer side-terminal, and the ink outlet matches with the ink supply part, so that the ink in the ink chamber is supplied to a print head of the printer for providing ink for printing.

**[0074]** However, although the hole in the mounting part limits the movement of the clamping portion in up and down directions and the back and forth movement in a horizontal direction, it cannot limit the left and right movement of the clamping portion in the horizontal direction, resulting in that the chip cannot form a good electrical connection with the printer side-terminal or the printer cannot correctly identify the chip of the ink cartridge.

**[0075]** FIG. 9 is a structural schematic view of a mounting part according to Embodiment 3 of the present appli-

cation; FIG. 10 is a partial cross-sectional structural schematic view of the mounting part in FIG. 9; FIG. 11 is an enlarged structural schematic view at position A in FIG. 10; FIG. 12 is a structural schematic view of the printer side-terminal part of FIG. 9; FIG. 13 is a structural schematic view of a first ink cartridge according to Embodiment 3 of the present application; FIG. 14 is an enlarged structural schematic view at position B in FIG. 13; and FIG. 15 is a structural schematic view showing the matching between the ink cartridge of FIG. 13 and a mounting part.

**[0076]** As shown in FIG. 9 to FIG. 15, the ink cartridge 40 provided in the present application includes a cartridge body 420 and a chip 440; the cartridge body 420 includes a second wall 40b and a first wall 40a which are disposed opposite to each other, a third wall 40c and a fourth wall 40d which are disposed opposite to each other, and a sixth wall 40f and a fifth wall 40e which are disposed opposite to each other. The first wall 40a is provided with an ink outlet 430 adapted to the ink supply part 330 of the mounting part 30; and the third wall 40c is provided with a chip 440 at a position near the first wall 40a. At least one of the third wall 40c, the sixth wall 40f and the fifth wall 40e is provided with a positioning part 450 for clamping with a first bayonet 3011 of the mounting part 30, and the first bayonet 3011 is disposed on at least one of the mounting plates 35 on both sides of the printer side-terminal part in the mounting part 30. When the positioning part 450 is clamped with the first bayonet 3011, a top surface 4501 of the positioning part 450 abuts against a locking surface 3501 at the top of the first bayonet 3011, and a side surface 4502 of the positioning part 450 abuts against a side surface forming the first bayonet 3011.

**[0077]** The mounting part 30 includes printer side-terminal parts, mounting plates 35, an ink supply part 330 and a mounting chamber 320. A plurality of printer side-terminal parts are arranged on a side wall of the mounting part 30 for electrical connection with the chip 440. A plurality of mounting plates 35 are also disposed on the side wall of the mounting part 30 for fixing the plurality of printer side-terminal parts on the side wall and separating the plurality of printer side-terminal parts from each other so as to avoid short circuit between the printer side-terminal parts.

**[0078]** Specifically, the mounting part 30 includes a mounting chamber 320, an ink supply part 330 and printer side-terminal parts. The bottom wall 30a of the mounting part and the opening 30b are oppositely disposed, the first side wall 30c and the second side wall 30d are oppositely disposed, and the third side wall 30e and the fourth side wall 30f are oppositely disposed. The bottom wall 30a, the first side wall 30c, the second side wall 30d, the third side wall 30e and the fourth side wall 30f enclose the mounting chamber 320 for accommodating the ink cartridge 40. The ink supply part 330 is disposed on the bottom wall 30a of the mounting part, and the printer side-terminal parts are disposed on the first side wall 30c.

Three-dimensional rectangular coordinate system, XYZ coordinate system is established. X-axis, Y-axis and Z-axis are perpendicular to each other. A direction of the bottom wall 30a of the mounting part pointing to the opening 30b is a +Z-axis direction, a direction of the second side wall 30d pointing to the first side wall 30c is a +X-axis direction, and a direction of the third side wall 30e pointing to the fourth side wall 30f is a +Y-axis direction.

**[0079]** The printer side-terminal part has a base 361, a stylus 362, a slot 363, a first side-terminal part protrusion 364 and a second side-terminal part protrusion 365. The first side-terminal part protrusion 364 includes a first protrusion lower surface 3641 and a first protrusion front surface 3642, and the second side-terminal part protrusion 365 includes a second protrusion lower surface 3651 and a second protrusion front surface 3652. The first protrusion lower surface 3641 and the second protrusion lower surface 3651 may be horizontal surfaces, inclined surfaces and curved surfaces, etc., and it is not specifically limited in the present application. The first protrusion front surface 3642 and the second protrusion front surface 3652 may be plumb surfaces, inclined surfaces and curved surfaces, etc., and it is not specifically limited in the present application. The first side-terminal part protrusion 364 and the second side-terminal part protrusion 365 are disposed on the -Y-axis side and +Y-axis side of the base 361, respectively. The groove 3502 is a part where the printer side-terminal part is mounted, and the printer side end part is mounted and fixed (a fixed position is not shown in the figure) in the mounting part 30 along the Z-axis direction under the action of the groove 3502. The mounting plate 35 is provided with a locking surface 3501, an inner opposing surface 3505 and a groove 3502. The locking surface 3501 may be a horizontal surface, an inclined surface, a curved surface, an arc surface, etc., and it is not specifically limited in the present application. As shown in FIG. 10, two locking surfaces 3501 are provided on left and right sides of the mounting plate 35, and the locking surface 3501 on the left side is provided in a left-side mounting position. The locking surface 3501 on the right side is provided in a right-side mounting position. The locking surface 3501 on the left side is provided to be an arc surface, and the locking surface 3501 on the right side is provided to be an inclined surface. Preferably, the locking surface 3501 is provided to be a horizontal surface. One end of the groove 3502 is provided with an opening facing the mounting chamber 320, an upper surface of the opening is the locking surface 3501, a side surface of the opening is the inner opposing surface 3505, and the groove 3502 is used for fixing and mounting the printer side-terminal part.

**[0080]** It should be noted that the ink cartridge 40 is mounted in the mounting chamber 320 of the mounting part 30. The mounting part 30 may have one or more mounting positions which may respectively accommodate one or more (for example, four) ink cartridges 40. The ink cartridges 40 may be ink cartridges 40 of the same color (for example, black), and may also be ink

cartridges 40 with four different colors (for example, black, red, yellow and blue), and it is not specifically limited in the present application. Each mounting position has corresponding printer side-terminal part, mounting plate 35, ink supply part 330, groove 3502, locking surface 3501, etc.

**[0081]** The cartridge body 420 includes a second wall 40b and a first wall 40a which are oppositely disposed, a third wall 40c and a fourth wall 40d which are oppositely disposed, and a sixth wall 40f and a fifth wall 40e which are oppositely disposed, and the cartridge body 420 may be placed in a corresponding mounting position in the mounting chamber 320. The ink outlet 430 on the first wall 40a matches with the ink supply part 330 of the mounting part 30. A chip 440 is disposed near a bottom of the third wall 40c, and may be electrically connected with the printer side-terminal part. The third wall 40c and the fourth wall 40d are approximately perpendicular to the first wall 40a and the second wall 40b, and the sixth wall 40f and the fifth wall 40e are approximately perpendicular to the first wall 40a and the second wall 40b. Further, there may be only one positioning unit 450, and there may also be two or more positioning units 450. Three-dimensional rectangular coordinate system XYZ coordinate system is established. The X-axis, Y-axis and Z-axis are perpendicular to each other. A direction of the first wall 40a pointing to the second wall 40b is a +Z-axis direction, a direction of the fourth wall 40d pointing to the third wall 40c is a +X-axis direction, and a direction of the fifth wall 40e pointing to the sixth wall 40f is a +Y-axis direction.

**[0082]** At least one of the third wall 40c, the sixth wall 40f and the fifth wall 40e is provided with a positioning part 450 for clamping with the first bayonet 3011 of the mounting part 30. The first bayonet 3011 is enclosed by the locking surface 3501 and the inner opposing surface 3505 of the mounting plate 35.

**[0083]** When the positioning part 450 is stuck in the first bayonet 3011, the top surface 4501 of the positioning part 450 abuts against the locking surface 3501 on the top of the first bayonet 3011, and the side surface 4502 of the positioning part 450 abuts against the inner opposing surface 3505 of the mounting plate 35, thereby limiting the movement of the top surface 4501 and the side surface 4502 of the positioning part 450, and the ink cartridge 40 is then fixed to the mounting part 30, so that the chip 440 forms a good electrical connection with the printer side-terminal part, thereby improving the printing quality.

**[0084]** The ink cartridge 40 provided in the present application limits the movement of the top surface 4501 and the side surface 4502 of the positioning part 450 by the first bayonet 3011 on the mounting part 30, so that the chip 440 forms a good electrical connection with the printer side-terminal part, and the problem that the mounting part of the printer cannot limit the left and right movement of the clamping position in the horizontal direction is solved, thereby improving the printing quality.

**[0085]** Optionally, an end surface 4503 of the position-

ing part 450 is configured to match with a guiding surface 3503 on the top of the first bayonet 3011.

**[0086]** The mounting plate 35 is also provided with the guiding surface 3503. The guiding surface 3503 is provided on a surface of the mounting plate 35 facing the mounting chamber 320. The guiding surface 3503 may be a plumb surface, an inclined surface, a curved surface, etc., and it is not specifically limited here in the present application. As shown in FIG. 10, two guide surfaces, left and right guide surfaces 3503 are provided on the mounting plate 35. The left guiding surface 3503 is provided in the mounting position on the left side of the mounting plate 35. The right guiding surface 3503 is provided in the mounting position on the right side of the mounting plate 35. The left guiding surface 3503 is set to be a plumb surface, and the right locking surface 3501 is set to be an inclined surface.

**[0087]** The end surface 4503 of the positioning part 450 matches with the guiding surface 3503. When the end surface 4503 of the positioning part 450 abuts against the guiding surface 3503, the guiding surface 3503 may guide the ink cartridge 40 to move along the guiding surface 3503.

**[0088]** In an optional implementation, the guiding surface 3503 is a plumb surface. When the ink cartridge 40 is mounted to the mounting part 30, the cartridge body 420 is first placed in the mounting chamber 320. The end surface 4503 of the positioning part 450 abuts against the guiding surface 3503, and the ink cartridge 40 moves along the guiding surface 3503 toward the bottom wall 30a of the mounting part. Then, the positioning part 450 reaches the opening of the groove 3502, the ink cartridge 40 integrally approaches the opening of the groove 3502, and the top surface 4501 of the positioning part 450 abuts against the locking surface 3501 on the top of the first bayonet 3011, and the side surface 4502 of the positioning part 450 abuts against the inner opposing surface 3505 of the mounting plate 35, so that the chip 440 forms a good electrical connection with the printer side-terminal part.

**[0089]** It should be noted that the top surface 4501 of the positioning part 450 abuts against the locking surface 3501 on the top of the first bayonet 3011, which can prevent the ink cartridge 40 from being detached from the mounting chamber 320. The side surface 4502 of the positioning part 450 abuts against the inner opposing surface 3505 of the mounting plate 35, which can prevent the ink cartridge 40 from moving in the direction the side surface 4502.

**[0090]** In another optional implementation, the first bayonet 3011 may consist of a lower surface of first protrusion 3641 and a first surface 3643 of the printer side-terminal part. The first bayonet 3011 may also consist of a front surface of second protrusion 3652 and a second surface 3653 of the printer side-terminal part. When the ink cartridge 40 is mounted to the mounting part 30, the cartridge body 420 is first placed in the mounting chamber 320, the end surface 4503 of the positioning part 450

abuts against the guiding surface 3503, the ink cartridge 40 moves along the guiding surface 3503 toward the bottom wall 30a of the mounting part, and then the positioning part 450 reaches the opening of the groove 3502.

5 The ink cartridge 40 integrally approaches the opening of the groove 3502, and the end surface 4503 of the positioning part 450 abuts against a front surface of first protrusion 3642 and/or the front surface of second protrusion 3652. The ink cartridge 40 continues to move  
10 along the front surface of first protrusion 3642 and/or the front surface of second protrusion 3652 toward the bottom wall 30a of the mounting part. When the positioning part 450 reaches a notch (the first bayonet 3011) below the lower surface of first protrusion 3641 and/or the lower  
15 surface of second protrusion 3651, the ink cartridge 40 integrally approaches the notch below the lower surface of first protrusion 3641 and/or the lower surface of second protrusion 3651. The top surface 4501 of the positioning part 450 abuts against the lower surface of first protrusion  
20 3641 and/or the lower surface of second protrusion 3651, and the side surface 4502 of the positioning part 450 abuts against the first surface 3643 and/or the second surface 3653, so that the chip 440 forms a good electrical connection with the printer side-terminal part.

25 **[0091]** Optionally, the end surface 4503 of the positioning part 450 is disposed to be an arc surface.

**[0092]** In order to facilitate the movement of the end surface 4503 of the positioning part 450 on the guiding surface 3503, the end surface 4503 of the positioning part 450 is disposed as an arc surface.  
30

**[0093]** Optionally, a distance between the positioning part 450 and the second wall 40b is greater than a distance between the positioning part 450 and the chip 440.

**[0094]** In order to accurately locate the position of the chip 440, the distance between the positioning part 450 and the second wall 40b is greater than the distance between the positioning part 450 and the chip 440. That is, the positioning part 450 is closer to the chip 440 than the second wall 40b, so that the chip 440 forms a good electrical connection with the printer side-terminal part.  
35  
40

**[0095]** Exemplarily, as shown in FIG. 13, the distance between the positioning part 450 and the second wall 40b is D1, the distance between the positioning part 450 and the chip 440 is D2, and  $D1 > D2$ .

**[0096]** The present application also provides an ink cartridge, including a cartridge body 420 and a chip 440. The cartridge body 420 includes a first wall 40a and a second wall 40b which are oppositely disposed, a third wall 40c and a fourth wall 40d which are oppositely disposed, and a fifth wall 40e and a sixth wall 40f which are oppositely disposed. An ink outlet 430 for matching with an ink supply part 330 of a mounting part 30 is disposed on the first wall 40a. A chip 440 is disposed at a position of the third wall 40c close to the first wall 40a. At least one of the third wall 40c, the fifth wall 40e and the sixth wall 40f is provided with a positioning part 450 for clamping with a first bayonet of the mounting part 30, and the first bayonet is disposed in at least one of mounting plates

35 on both sides of a printer side-terminal part of the mounting part 30. The distance between the positioning part 450 and the second wall 40b is greater than the distance between the positioning part 450 and the chip 440. In the ink cartridge also provided in the present application, through the position relationship between the positioning part 450 and the chip 440, the positioning part 450 is closer to the chip 440 than the second wall 40b, so that the chip 440 forms a good electrical connection with the printer side-terminal part, which avoids the positioning part 450 failing to accurately locate the position of the chip due to being far away from the chip.

**[0097]** Optionally, the third wall 40c is provided with two positioning parts 450.

**[0098]** In order for the ink cartridge 40 to move smoothly along the guiding surface 3503 into the mounting chamber 320, two positioning parts are disposed on the third wall 40c.

**[0099]** Specifically, there are two positioning parts 450, which are arranged at both ends of the Y-axis direction of the third wall 40c respectively. Such arrangement can play a balancing role.

**[0100]** Exemplarily, two positioning parts 450 are disposed on the third wall 40c, the end surface 4503 of the positioning part 450 is an arc surface, and the guiding surface 3503 is a plumb surface. When the ink cartridge 40 is mounted to the mounting part 30, the cartridge body 420 is first placed in the mounting chamber 320. The end surfaces 4503 of the two positioning parts 450 abut against the two guide surfaces 3503 respectively, and the ink cartridge 40 moves along the guiding surface 3503 into the mounting chamber 320. Then, the positioning part 450 reaches the opening of the groove 3502, and the ink cartridge 40 integrally approaches the opening of the groove 3502. The top surface 4501 of the positioning part 450 abuts against the locking surface 3501 on the top of the first bayonet 3011, the side surface 4502 of the positioning part 450 abuts against the inner opposing surface 3505 of the mounting plate 35, so that the chip 440 forms a good electrical connection with the printer side-terminal part.

**[0101]** It should be noted that the number of positioning part 450 may also be one or greater than two, and it is not specifically limited in the present application.

**[0102]** FIG. 16 is a structural schematic view of a second ink cartridge according to Embodiment 3 of the present application; and FIG. 17 is a structural schematic view showing the matching between the ink cartridge provided in FIG. 16 and a mounting part.

**[0103]** Optionally, two positioning parts 450 are located at the same height.

**[0104]** Two positioning parts 450 are disposed on the third wall 40c, and located at the same height.

**[0105]** In an optional implementation, as shown in FIG. 16 and FIG. 17, two positioning parts 450 are disposed on the third wall 40c and located at the same height, and shapes of the two positioning parts 450 are different. A top surface 4501 of one positioning part 450 may be dis-

posed as an inclined surface, and a top surface 4501 of the other positioning part 450 may be disposed as a horizontal surface. The locking surfaces 3501 of the two mounting plates 35 in the mounting part 30 match with the top surfaces of the two positioning parts 450 respectively, that is, the locking surface 3501 of one mounting plate 35 may be disposed as the inclined surface, and the locking surface 3501 of the other mounting plate 35 is disposed as the horizontal surface. The two positioning parts 450 of different shapes abut against the locking surfaces 3501 of the two mounting plates 35 respectively, so that the ink cartridge 40 has a certain floating space, thereby preventing the ink cartridge 40 from getting stuck in the mounting part 30.

**[0106]** In another optional implementation, two positioning parts 450 are disposed on the third wall 40c and located at the same height, and the two positioning parts 450 are of the same shape. Top surfaces 4501 of the two positioning parts 450 may be disposed as arc surfaces. The locking surfaces 3501 of the two mounting plates 35 in the mounting part 30 matches with the top surfaces 4501 of the two positioning parts 450 respectively, that is, the locking surfaces 3501 are arc surfaces. By abutting the two positioning parts 450 against the locking surfaces 3501 of the two mounting plates 35 respectively, the chip 440 may be electrically connected to the printer side-terminal part accurately.

**[0107]** Optionally, a top surface 4501 of one positioning part 4501 is disposed as an arc surface, and a top surface 4501 of the other positioning part 450 is disposed as a plane.

**[0108]** Exemplarily, two positioning parts 450 are disposed on the third wall 40c, and located at the same height, and shapes of the two positioning parts 450 are different. A top surface 4501 of one positioning part 450 may be disposed as an arc surface, and a top surface 4501 of the other positioning part 450 may be disposed as a horizontal surface. The locking surfaces 3501 of the two mounting plates 35 in the mounting part 30 match with the top surfaces 4501 of the two positioning parts 450 respectively, that is, the locking surface 3501 of one mounting plate 35 may be disposed as an arc surface, and the locking surface 3501 of the other mounting plate 35 is disposed as a horizontal surface. The two positioning parts 450 of different shapes abut against the locking surfaces 3501 of the two mounting plates 35 respectively, so that the ink cartridge 40 has a certain floating space, thereby avoiding the ink cartridge 40 from getting stuck in the mounting part 30.

**[0109]** It should be noted that when the ink cartridge 40 is mounted to the mounting part 30, the top surface 4501 of the positioning part 450 abuts against the locking surface 3501. In order to facilitate the detachment of the ink cartridge 40, tilt directions of the top surface 4501 and the locking surface 3501 are set to be the same.

**[0110]** Optionally, a handle 470 is disposed at a position of the third wall 40c close to the second wall 40b, or the handle 470 is disposed at a position of the fourth wall

40d close to the second wall 40b.

**[0111]** In an optional implementation, as shown in FIG. 13, in order to facilitate the removal of the ink cartridge 40 in the mounting part 30, the third wall 40c is provided with a handle 470 near the second wall 40b, so that the ink cartridge 40 has a certain moving space in the X-axis direction, and it can ensure that the ink cartridge can be better fixed to the mounting part 30. Where the handle 470 may be bent under the action of external force, and when the external force disappears, the handle 470 may return to its initial state. Preferably, the handle 470 is an elastic member. Adding an elastic member on the -X-axis side of the ink cartridge 40 may allow the ink cartridge 40 to have a certain moving space in the X-axis direction, and may ensure that the ink cartridge 40 can be better fixed to the mounting part 30. The elastic member may be an elastic material, such as a movable member, a spring, silica gel, rubber and other elastic materials, which has a certain distance from the cartridge body 420.

**[0112]** In another optional implementation, as shown in FIG. 15, in order to better adjust the position of the ink cartridge 40 in the mounting part 30, the fourth wall 40d is provided with a handle 470 near the second wall 40b. Where the handle 470 may be bent under the action of external force, and when the external force disappears, the handle 470 may return to its initial state. When the ink cartridge 40 is mounted to the mounting part 30, the handle 470 on the fourth wall 40d is in contact with a wall of the mounting chamber 320, and the position of the ink cartridge 40 in the mounting part 30 may be adjusted by the handle 470, so that the chip 440 is in good contact with the printer side-terminal part.

**[0113]** It should be noted that, as shown in FIG. 17, the handle 470 on the fourth wall 40d may also have the function of being convenient to be taken out and the function of adjustment.

**[0114]** FIG. 18 is a structural schematic view of a third ink cartridge according to Embodiment 3 of the present application.

**[0115]** As shown in FIG. 18, a cartridge body 420 includes an ink capsule 421 and an adapter 422. An ink outlet 430 is disposed on the ink capsule 421, and the inside of the ink capsule 421 may be filled with ink. A positioning part 450, a chip 440 and an ink outlet hole 431 are disposed on the adapter 422. When the ink capsule 421 is placed on the adapter 422, the ink outlet 430 may be inserted into the ink outlet hole 431, so that after the ink in the ink capsule 421 is used up, a new ink capsule 421 may be replaced, thereby enabling the adapter 422 to be reused, which achieves an effect that adapter 422, especially the chip, can be recycled.

**[0116]** In this embodiment, a positioning part 450 and an anti-jamming part 460 are disposed on the third wall 40c. The anti-jamming part 460 is closer to the +Z-axis direction than the positioning part 450. As shown in FIG. 18, at least a portion of the anti-jamming part 460 is at a +Z-axis direction side of a topmost line L of the positioning part 450 in the Z-axis direction. And in the X-axis direc-

tion, the positioning part 450 is more prominent to the cartridge body 420 than the anti-jamming part 460. When the ink cartridge 40 is mounted to the mounting part 30, the positioning part 450 matches with a first bayonet 3011 to prevent the ink cartridge 40 from detaching from the mounting part 30. The surface on the most +X-axis side of the anti-jamming part 460 abuts against a guiding surface 3503 to prevent the ink cartridge 40 from being excessively to the +X-axis direction and avoid that the ink cartridge 40 cannot be normally taken out.

**[0117]** Furthermore, the positioning part 450 and the anti-jamming part 460 may be made in the form of movable members, and when the ink capsule 421 matches with the adapter 422, the positioning part 450 and the anti-jamming part 460 protrude from a third wall 40c to a specified state, which may match with the mounting part 30, so that the ink cartridge 40 is mounted to the mounting part 30. When the ink cartridge 40 is detached from the adapter 422, the positioning part 450 and the anti-jamming part 460 may retract a certain distance, so that the adapter 422 may not clamped with the mounting part 30 temporarily, and the chip 440 is not electrically connected with the printer side-terminal part, and only when the new ink capsule 421 matches with the adapter 422 again, the ink cartridge 40 may match with the mounting part 30 and the ink cartridge 40 is mounted to the mounting part 30.

**[0118]** Optionally, the positioning part 450 is perpendicular to a side wall on which the positioning part 450 is disposed.

**[0119]** When the positioning part 450 is perpendicular to the side wall on which the positioning part 450 is disposed, the positioning part 450 is in direct contact with the side wall on which the positioning part 450 is disposed.

**[0120]** FIG. 19 is a structural schematic view of a fourth ink cartridge according to Embodiment 3 of the present application.

**[0121]** Optionally, the positioning part 450 is parallel to the side wall on which the positioning part 450 is disposed.

**[0122]** As shown in FIG. 19, when the positioning part 450 is parallel to the side wall on which the positioning part 450 is disposed, an extension wall 4504 is disposed between the positioning part 450 and the side wall on which the positioning part 450 is disposed.

**[0123]** In an optional implementation, two extension walls 4504 are disposed on the third wall 40c, and two positioning parts 450 are disposed at ends of the two extension walls 4504, respectively. The two positioning parts 450 are parallel to the third wall 40c, and the two positioning parts 450 are vertically connected with the two extension walls 4504 respectively. When the ink cartridge 40 is mounted in the mounting part 30, the cartridge body 420 is first placed in the mounting chamber 320, the two extension walls 4504 abut against first side surfaces 3504 of the mounting plate 35 respectively, and end surfaces 4503 of the two positioning parts 4503 abut

against the two first side surfaces 3504 respectively. The ink cartridge 40 moves into the mounting chamber 320 along the first side surfaces 3504, and then the positioning part 450 reaches an opening of a groove 3502, and a top surface 4501 of the positioning part 4501 abuts against a locking surface 3501 on the top of a first bayonet 3011, and the two extension walls 4504 abut against the first side surfaces 3504 of the mounting plate 35 respectively so that the chip 440 forms a good electrical connection with the printer side-terminal part.

**[0124]** It should be noted that the extension wall 4504 is bendable under the action of an external force, and when the external force disappears, the extension wall 4504 may return to its initial state.

**[0125]** Optionally, the positioning part 450 is located above the chip 440, and the positioning part 450 is configured for clamping with the first bayonet 3011 of the mounting plate 35.

**[0126]** The locking surface 3501 and an inner opposing surface 3505 of the mounting plate 35 enclose the first bayonet 3011, which is configured for clamping with the positioning part 450 above the chip 440.

**[0127]** FIG. 20 is a partial structural schematic view of another mounting part according to Embodiment 3 of the present application; and FIG. 21 is a partial structural schematic view of a fifth ink cartridge according to Embodiment 3 of the present application.

**[0128]** Optionally, the positioning part 450 is located below at least a portion of terminals of the chip 440 and is configured for clamping with a second bayonet 3012 of the mounting plate 35.

**[0129]** As shown in FIG. 20 and FIG. 21, the second bayonet 3012 is a groove disposed at a bottom end of the mounting plate 35, and a position of the positioning part 450 corresponds to a position of the second bayonet 3012. When the ink cartridge 40 is mounted to the mounting part 30, the second bayonet 3012 is configured for clamping with the positioning part 450.

**[0130]** In the Y-axis direction, the number of positioning part 450 may also be two, and when the ink cartridge 40 is mounted to the mounting part 30, each of the two positioning parts 450 is connected with the second bayonet 3012.

**[0131]** FIG. 22 is a structural schematic view of a sixth ink cartridge according to Embodiment 3 of the present application.

**[0132]** Optionally, a sixth wall 40f and a fifth wall 40e are each provided with one positioning part 450.

**[0133]** Exemplarily, as shown in FIG. 22, the sixth wall 40f and the fifth wall 40e are each provided with one positioning part 450, the two positioning parts 450 are at the same height, and the two positioning parts 450 are the same. When the ink cartridge 40 is mounted to the mounting part 30, the ink cartridge 40 is first integrally placed in the mounting chamber 320, then the ink cartridge 40 integrally approaches an opening of a groove 3502, and the sixth wall 40f and the fifth wall 40e extend into an area enclosed by the adjacent mounting plates

35, a top surface 4501 of the positioning part 450 abuts against a locking surface 3501 on the top of a first bayonet 3011, and an end surface 4503 of the positioning part 450 abuts against an inner opposing surface 3505 of the mounting plate 35, so that the chip 440 forms a good electrical connection with the printer side-terminal part.

**[0134]** It should be noted that a spacing between the sixth wall 40f and the fifth wall 40e is smaller than a spacing between two adjacent mounting plates 35.

**[0135]** It should be pointed out that the two positioning parts 450 on the ink cartridge 40 may be injection-molded bulges which are integrated with the cartridge body 420; or the two positioning parts 450 may be configured on a replaceable part so that the same structure may match with a variety of different ink cartridge structures; they may also be bulging parts that are mounted on the third wall 40c by means of separate sticking, clamping, etc.; in addition, they may also be elastic bulging parts that are mounted on the third wall 40c by means of sticking, clamping, interference fit, etc., and the elastic bumping part may be made of a material such as silicone, rubber, cork and the like.

#### Embodiment 4

**[0136]** FIG. 23 is a structural schematic view of a mounting part according to Embodiment 4 of the present application; FIG. 24 is a structural schematic view of a printer terminal part in FIG. 23; FIG. 25 is a schematic view of a stylus in an ink cartridge according to Embodiment 4 of the present application; FIG. 26 is a structural schematic view of the ink cartridge according to Embodiment 4 of the present application; FIG. 27 is an enlarged view of position A in FIG. 26; FIG. 28 is a schematic view of a chip in the ink cartridge according to Embodiment 4 of the present application; FIG. 29 is an enlarged view of an engaging part in the ink cartridge according to Embodiment 4 of the present application; FIG. 30 is a cross-sectional view showing a matching between the ink cartridge and the mounting part according to Embodiment 4 of the present application; and FIG. 31 is a cross-sectional view showing another matching between the ink cartridge and the mounting part according to Embodiment 4 of the present application.

**[0137]** As shown in FIG. 23 to FIG. 31, an ink cartridge 40 includes a cartridge body 420 and a chip 440. The ink cartridge 40 is detachably connected with a mounting part 30 of a printer, and a printer side-terminal part is disposed on the mounting part 30. Ink is accommodated in the cartridge body 420, and the chip 440 is disposed on a third wall 40c of the cartridge body 420. The cartridge body 420 has an ink outlet 430 and an engaging part 423, the ink outlet 430 is disposed on a first wall 40a that is intersected with the third wall 40c, the ink outlet 430 and the chip 440 are disposed adjacent to each other, and the engaging part 423 is disposed on the third wall 40c. When the ink cartridge 40 is connected with the printer mounting part 30, the engaging part 423 engages with

a stylus of the printer side-terminal part, so that the ink cartridge 40 is connected and fixed with the mounting part 30 of printer, thereby preventing the ink cartridge 40 from being detached from the mounting part 30 of printer.

**[0138]** As shown in FIG. 23, the mounting part 30 is a component having an opening 30b and having a substantially cuboid shape. The mounting part 30 has a bottom wall 30a, the opening 30b, a first side wall 30c, a second side wall 30d, a third side wall 30e and a fourth side wall 30f. The mounting part 30 includes a mounting chamber 320, a plurality of mounting positions, an ink supply part 330, a printer side-terminal part and a mounting plate 35. The bottom wall 30a and the opening 30b are oppositely disposed, the first side wall 30c and the second side wall 30d are oppositely disposed, and the third side wall 30e and the fourth side wall 30f are oppositely disposed. The bottom wall 30a, the first side wall 30c, the second side wall 30d, the third side wall 30e and the fourth side wall 30f enclose the mounting chamber 320 for accommodating the ink cartridge 40. The ink supply part 330 is disposed on the bottom wall 30a, and the printer side-terminal part is disposed on the first side wall 30c. Three-dimensional rectangular coordinate system, XYZ coordinate system is established. The X-axis, the Y-axis and the Z-axis are perpendicular to each other. A direction of the bottom wall 30a pointing to the opening 30b is a +Z-axis direction, a direction of the second side wall 30d pointing to the first side wall 30c is a +X-axis direction, and a direction of the third side wall 30e pointing to the fourth side wall 30f is a +Y-axis direction. A plurality of printer side-terminal parts and a plurality of mounting plates 35 are disposed on the first side wall 30c. The mounting part 30 is also provided with a plurality of mounting plates 35 on its side wall. The plurality of mounting plates 35 are configured for fixing the plurality of printer side-terminal parts to the first side wall 30c, and spacing the plurality of printer side-terminal parts from each other to avoid occurrence of a short circuit between two printer side-terminal parts. The mounting part 30 may accommodate four ink cartridges 40, and have four mounting positions, each mounting position having one corresponding printer side-terminal part, and adjacent printer side-terminal parts are spaced apart by a corresponding mounting plate 35. The four mounting positions may be a first mounting position 31, a second mounting position 32, a third mounting position 33 and a fourth mounting position 34 respectively.

**[0139]** As shown in FIG. 23 and FIG. 24, the printer terminal part has a plurality of printer side-terminal parts, which have the same structure. Taking one of the printer side-terminal parts as an example, the printer side-terminal part has a base 361, a stylus 362 and a slot 363. The stylus 362 is a metal sheet in a form of a thin sheet, may have a conductive effect and is not easy to wear. The base 361 has a plurality of slots 363, which correspond to a plurality of stylus 362 one by one. The plurality of slots 363 each have a U shape, and have slits in the +Z-axis direction. The plurality of styluses 362 are re-

spectively mounted in the plurality of slots 363 through the slits along the -Z-axis direction.

**[0140]** One side of each stylus 362 of the printer side-terminal part is connected to a main circuit of the inkjet printer through a circuit inside the mounting part 30; and the other side of each stylus 362 is connected to the chip of the ink cartridge 40. The structures of respective styluses 362 are consistent, as shown in FIG. 25. Taking the stylus 362 as an example, the stylus 362 is divided into a first portion 362a, a second portion 362b and a third portion 362c. The first portion 362a or the third portion 362c is configured for contacting with the chip of the ink cartridge; and the second portion 362b is configured for connecting with an internal circuit of the inkjet printer, for example, it is connected with the main circuit in the inkjet printer through a holding chip. The third portion 362c is connected with the first portion 362a and the second portion 362b. The first portion 362a is divided into a slope portion 362x, a tip portion 362y and a bottom portion 362z. For the first portion 362a, the tip portion 362y is located at the widest position of the X-axis, a portion at the +Z-axis direction side of the tip portion 362y is the slope portion 362x, and a portion at the -Z-axis direction side of the tip portion 362y is the bottom portion 362z.

**[0141]** The third portion 362c is connected with the first portion 362a and the second portion 362b. The third portion is located in the +Z-axis direction of the stylus 362, and the stylus 362 is fixed in the slot 363 by the third portion 362c or a portion of the third portion 362c (for example, a horizontal portion 362h of the third portion 362c). The first portion 362a and the second portion 362b are disposed at ends in the -Z-axis direction of the stylus 362, so that the first portion 362a and the second portion 362b may be elastically deformed and easily return to their original states after deformation. The first portion 362a of the stylus 362 is disposed in the -X-axis direction, and the second portion 362b is disposed in the +X-axis direction. The first portion 362a and the second portion 362b protrude from the base 361, the third portion 362c is not protruding from the base 361. Further, the first portion 362a and the second portion 362b protrude from the base 361 in the X-axis direction, and the base 361 is located between the first portion 362a and the second portion 362b. The third portion 362c is divided into a first vertical portion 362k and a second vertical part 362j that are perpendicular to the X-axis direction and a horizontal portion 362h parallel to the X-axis direction; and the horizontal portion 362h connects the first vertical part 362k and the second vertical part 362j. The first vertical portion 362k and the second vertical portion 362j extend in the Z-axis direction. The first vertical portion 362k is closer to the first mounting position 31 than the second vertical portion 362j. An end of the first vertical portion 362k is connected with the first portion 362a, and an end of the second vertical portion 362j with the second portion 362b. When the horizontal portion 362h or the first vertical portion 362k and the second vertical part 362j are fixed in the slot 363 in the +Z-axis direction, such structure of the

stylus 362 may make the first portion 362a and the second portion 362b of the stylus 362 elastic, which avoids that the chip and the adjacent stylus 362 are worn due to rigid contact with the internal circuit of the inkjet printer and the chip of the ink cartridge.

**[0142]** It should be noted that the ink cartridge 40 is mounted in the mounting chamber 320 of the mounting part 30. The mounting part 30 may have one or more mounting positions which may respectively accommodate one or more (for example, four) ink cartridges 40. The ink cartridges 40 may be ink cartridges 40 of the same color (for example, black) or four different colors (for example, black, red, yellow and blue), which is not specifically limited in the present application. Each mounting position has corresponding printer side-terminal part, a mounting plate 35, an ink supply part 330, and the like.

**[0143]** Ink is accommodated in the cartridge body 420, and the cartridge body 420 may be placed in the corresponding mounting position in the mounting chamber 320. The cartridge body 420 has a third wall 40c, which is one of the two side walls of the cartridge body 420, and the third wall 40c intersects with the first wall 40a of the cartridge body 420, and the chip 440 and the engaging part 423 are disposed on the third wall 40c. On the first wall 40a of the cartridge body 420, the ink outlet 430 is disposed. The ink outlet 430 is adapted to the ink supply part 330 of the mounting part 30, and the chip 440 may be electrically connected with the printer side-terminal part.

**[0144]** This embodiment provides an ink cartridge 40. By setting the engaging part 423 on the third wall 40c, when the ink cartridge 40 is connected with the mounting part 30, the engaging part 423 on the third wall 40c engages with the stylus 362 of the printer side-terminal part. On the one hand, the chip 440 is capable of forming a good electrical connection with the printer side-terminal part, and at the same time, it can ensure that the ink cartridge 40 and the mounting part of the printer are connected and fixed, thereby improving the print quality. When the ink cartridge 40 is mounted to the mounting part 30, the chip 440 contacts with the stylus 362 of the printer side-terminal part, and the engaging part 423 engages with the stylus 362, thereby preventing the ink cartridge 40 from being detached from the mounting part 30, and avoiding the position deviation caused by the engaging part 423 being away from the chip 440. At the same time, the structure is simple, it is easy to be produced and manufactured, the movement coordination between the parts will not get stuck, the production efficiency is high, and the cost is low.

**[0145]** In order to ensure the stability of the engagement between the engaging part 423 and the stylus 362, optionally, when the ink cartridge 40 is connected with the mounting part 30 of printer, the engaging part 423 engages with the bottom portion of the stylus 362.

**[0146]** In this embodiment, the engaging part 423 disposed on the third wall 40c engages with the bottom por-

tion 362z of the stylus, which prevents the ink cartridge 40 from being detached from the mounting part 30 and avoids the position deviation caused by the engaging part being away from the chip. At the same time, the structure is simple, it is easy to be produced and manufactured, the movement coordination between the parts will not get stuck, the production efficiency is high, and the cost is low.

**[0147]** Optionally, the engaging part 423 is a bulge disposed on the third wall 40c and extending in a direction away from the third wall 40c, that is, the engaging part 423 extends from the third wall 40c on the cartridge body 420 toward the outside of the cartridge body 420 and engages with the bottom portion of the stylus 362 as a bulge.

**[0148]** Optionally, the ink cartridge 40 includes a mounting surface 40c1, and the chip 440 is mounted on the mounting surface 40c1; the chip includes a substrate 4401, at least one recess part 4402 and at least one terminal disposed at intervals on the substrate 4401. At least one terminal is disposed on a side surface of the substrate 4401 intersecting with the mounting surface 40c1. The terminal has a contact part 4408, which is configured for abutting against the stylus 362 correspondingly, so that the electrical signals may be transmitted, stored and the like therebetween, thereby completing the transmission, the storage and the like of the electrical signal between the ink cartridge and the printer.

**[0149]** The terminals are disposed on the front surface or the front surface and the side surface (cross section) of the chip 440, and the contact parts 4408 of the plurality of terminals abut against the styluses 362 respectively, thereby completing the transmission, the storage and the like of the electrical signal.

**[0150]** Specifically, as shown in FIG. 28, a plurality of terminals are a left mounting detection terminal 441, a reset terminal 442, a clock terminal 443, a right mounting detection terminal 444, a power supply terminal 446, a ground terminal 447, a data terminal 448, a left high voltage terminal 445, and a right high voltage terminal 449, respectively, which match with the respective styluses 362, and the electrical signal may be transmitted, stored and the like therebetween, thereby completing the transmission, the storage and the like of the electrical signal between the ink cartridge and the printer.

**[0151]** The functions and effects of the respective terminals are as follows.

I. The reset terminal 442, the clock terminal 443, the power supply terminal 446, the ground terminal 447 and the data terminal 448 that are connected with a wafer are collectively referred to as a wafer terminal.

**[0152]** A reset terminal: the reset terminal 442 for resetting the internal data of the wafer.

**[0153]** A clock terminal: the clock terminal 443 for receiving a clock signal.

**[0154]** A power supply terminal: the power supply ter-

minal 446 for receiving a power potential (such as 3.6V) different from a ground potential, where a power for the wafer operation is provided through this terminal.

**[0155]** A ground terminal: the ground terminal 447 for receiving the ground potential.

**[0156]** A data terminal: the data terminal 448 for transmitting or receiving a data signal.

**[0157]** II. The left high voltage terminal 445 and the right high voltage terminal 449 which are capable of communicating with a high voltage power supply of the printer are collectively referred to as a high voltage terminal.

**[0158]** A first high voltage terminal (the left high voltage terminal 445) and a second high voltage terminal (the right high voltage terminal 449): configured to receive a mounting detection voltage (such as 42V) and complete the mounting detection function of the ink cartridge being mounted on the mounting part.

**[0159]** For example, a high resistance is connected between the first high voltage terminal and the second high voltage terminal, and whether the ink cartridge has been mounted in the mounting part is determined by detecting the change of current or voltage.

**[0160]** III. The left mounting detection terminal 441 and the right mounting detection terminal 444 which detect whether there is a short circuit between the wafer terminal and the high voltage terminal are collectively referred to as a short circuit terminal.

**[0161]** A first short circuit terminal (the left mounting detection terminal 441) and a second short circuit detection terminal (the right mounting detection terminal 444): configured to detect a short circuit between terminals, specifically, to detect whether the short circuit occurs between the high voltage terminal and the short circuit terminal.

**[0162]** When there is a short circuit between the high voltage terminal and the short circuit terminal, it may be detected by the printer that the voltage on the short circuit terminal is increased, and the printer immediately prompts a short circuit message, which avoids the risk of damage to the chip or the printer due to the short circuit.

#### IV. Extension terminals

**[0163]** Both the reset terminal 442 and the clock terminal 443 have outward extending portions, thereby becoming the extension terminals. As shown in FIG. 28, the extension terminals surround the short circuit terminals.

**[0164]** The terminals are arranged in a plurality of rows in the Z-axis direction, exemplarily, multiple terminals are arranged in four rows in the Z-axis direction, namely, a first row L1, a second row L2, a third row L3, and a fourth row L4. Specifically, the left mounting detection terminal 441 and the right mounting detection terminal 444 are arranged on the first row L 1; the reset terminal 442 and the clock terminal 443 are arranged on the second row L2; the power supply terminal 446, the ground terminal 447 and the data terminal 448 are arranged on the fourth

row L4; the left high voltage terminal 445 and the right high voltage terminal 449 are arranged on the third row L3. Further, the contact parts 4408 of the plurality of terminals are arranged in a plurality of rows, specifically, the plurality of the contact parts 4408 are arranged in four rows in the Z-axis direction.

**[0165]** Specifically, in this embodiment, a through hole 4403 is a part where the chip 440 is fixed to the ink cartridge 40. In particular, the through hole 4403 is fixed corresponding to a protruding part 424 on the ink cartridge 40. As shown in FIG. 26 to FIG. 28, in particular, the protruding part 424 in the ink cartridge 40 passes through the through hole 4403 and is fixed together with the chip 440 by hot melting, thereby fixing the chip 440 to the ink cartridge 40.

**[0166]** The recess parts 4402 are disposed below at least one terminal, that is, the recess parts 4402 are parts of one cross-section of the chip 440 in the -Z-axis. Furthermore, the recess parts 4402 correspond to -Z-axis positions of the left mounting detection terminal 441 and the left mounting detection terminal 444, respectively, so that the recess parts 4402 may accommodate at least one corresponding stylus 362, respectively. When the ink cartridge 40 is connected with the mounting part 30, the left mounting detection terminal 441 and the right mounting detection terminal 444 are in contact with the slope portions or the first vertical portions of the corresponding styluses, respectively.

**[0167]** Notches 4405 are parts of another cross-section of the chip 440 in the -Z-axis, and correspond to the -Z-axis positions of the left high voltage terminal 445 and the right high voltage terminal 449, respectively, so that the notches 4405 may each accommodate at least one corresponding stylus 362, respectively. When the ink cartridge 40 is connected with the mounting part 30, the left high voltage terminal 445 and the right high voltage terminal 449 are in contact with the slope portions or the first vertical portions of the corresponding styluses, respectively.

**[0168]** In order to ensure that through holes 4403 are each correspondingly fixed to bulging parts 4406 on the ink cartridge 40, optionally, at least one through hole 4403 is a through hole disposed on the substrate 4401. The recess part 4402 is the through hole disposed on the substrate 4401, and the engaging part 423 passes through the recess part 4402 to engage with the bottom portion of the corresponding stylus 362.

**[0169]** As shown in FIG. 28, a plurality of recess parts 4402, a plurality of through holes 4403 and a plurality of notches 4405 are disposed on the substrate 4401, where at least one through hole 4403 is a through hole disposed on the substrate 4401. When the chip 440 is fixed to a concave part 4404 of the ink cartridge 40, the recess part 4402 corresponds to the engaging part 423, and the engaging part 423 extends from the recess part 4402 to the outside of the ink cartridge 40, thereby engaging with the bottom portion of the outer stylus 362.

**[0170]** Further, the chip 440 has a plurality of rows of

contact parts 4408, and the engaging part 423 is disposed below certain row in the plurality of rows of the contact parts 4408. The chip 440 has a plurality of rows of contact parts 4408, and the engaging part 423 is disposed below a topmost first row of contact parts 4408 in plurality of rows of contact parts 4408. Specifically, the chip 440 has a plurality of rows of contact parts 4408, the engaging part 423 is disposed below a first row of contact parts 4408 in plurality of rows of contact parts 4408. Preferably, the concave parts 4402 correspond to the respective engaging parts 423 one by one.

**[0171]** Further, the engaging parts 423 may also engage with the bottom portion of the corresponding stylus through the notches 4405. The notches 4405 are disposed in the -Z-axis direction of the left high voltage terminal 445 and the right high voltage terminal 449 of the terminals respectively, and the corresponding stylus 362 may be inserted into a gap between the engaging part 423 and the left high voltage terminal 445/the right high voltage terminal 449.

**[0172]** In order to ensure that the engaging part 423 may engage with the bottom 362z of the stylus 362, thereby fixing the position of the stylus 362, optionally, the engaging part 423 is located below the bottom of the chip 440, and there is a gap between the engaging part 423 and the chip 440 for the stylus 362 to extend. When the ink cartridge 40 is mounted to the mounting part 30, the horizontal surface 4233 of the engaging part 423 engages with the bottom 362z of the first stylus 362z, which may ensure that the reaction force of the ink cartridge 40 to a first stylus 362 is not sufficient to deform the first stylus 362 in the -X-axis direction. When the ink cartridge 40 needs to be taken out, the user exerts a force on the ink cartridge 40 in the +Z-axis direction, so that the first stylus 362 is deformed in the +X-axis direction, thereby causing the ink cartridge 40 to be detached from the mounting part 30.

**[0173]** As shown in FIG. 29, the engaging part 423 includes a vertical surface 4231, a transition surface 4232, and a horizontal surface 4233. Where the contact part 4408 of the terminal of the chip 440 contacts with the slope portion 362x of the stylus 362, and at this time, the engaging part 423 engages with the bottom portion 362z of the stylus 362 to prevent the ink cartridge 40 from being detached from the mounting part 30 and better locate the position relationship between the ink cartridge 40, especially the chip 440 and the mounting part 30.

**[0174]** In an optional implementation, as shown in FIG. 26, in order to facilitate taking out the ink cartridge 40 from the mounting part 30, a handle 470 is disposed on one side of the third wall 40c, so that the ink cartridge 40 may have a certain moving space in the X-axis direction, and it may be ensured that the ink cartridge may be better fixed to the mounting part 30. The handle 470 may be bent under the action of external force, and when the external force disappears, the handle 470 may return to its initial state. Preferably, the handle 470 is an elastic member. Adding an elastic member on the -X-axis side

of the ink cartridge 40 may make the ink cartridge 40 have a certain moving space in the X-axis direction, and may ensure that the ink cartridge 40 may be better fixed to the mounting part 30. The elastic member may be a movable member, a spring, silica gel, rubber and other elastic material, which has a certain distance from the cartridge body 420.

**[0175]** A process of mounting the ink cartridge 40 to the mounting part 30 is as follows.

A. The ink cartridge 40 to be mounted is prepared, and the user holds the handle 470 and a rear side wall of the ink cartridge 40.

B. The ink cartridge 40 is moved from the opening 30b of the mounting part 30 to the bottom wall 30a along the -Z-axis direction.

C. The stylus 362 contacts with the engaging part 423 and deforms towards the +X-axis direction so that the engaging part 423 slides relatively along an outline of the first portion 362a, and the stylus 362 is also relatively deformed.

D. The ink cartridge 40 continues to move toward the -Z-axis direction, and when the engaging part 423 passes the stylus 362, the first portion 362a of the stylus 362 is located in a space between an opposite terminal and the engaging part 423; and at the same time, the ink cartridge is mounted in place, and the contact part 4408 of the terminal on the chip 440 is electrically connected with the stylus 362, and the ink outlet 430 matches with the ink supply part 330.

**[0176]** A process of taking the ink cartridge 40 out from the mounting part 30 is as follows.

A. The user holds the handle 470 and the rear side wall of the ink cartridge 40 and exerts a force on the ink cartridge in the +Z-axis direction.

B. The engaging part 423 slides relatively along the outline of the first portion 362a, and the stylus 362 is deformed in the +X-axis direction.

C. When the engaging part 423 of the ink cartridge 40 is detached from the stylus 362, the clamping effect of the mounting part 30 on the ink cartridge 40 is removed.

D. The ink cartridge 40 continues to move in the +Z-axis direction, so that the ink cartridge 40 may be taken out.

**[0177]** Further, as shown in FIG. 30, in this matching manner, when the ink cartridge 40 is mounted to the mounting part 30, the horizontal surface 4233 of the engaging part 423 engages with the bottom portion 362z of the stylus 362, which ensures that the reaction force of the ink cartridge 40 to the stylus 362 is not sufficient to deform the first stylus 362 in the -X-axis direction. When the ink cartridge 40 needs to be taken out, the user exerts a force on the ink cartridge 40 in the +Z-axis di-

rection, so that the stylus 362 is deformed in the +X-axis direction, thereby causing the ink cartridge 40 to be detached from the mounting part 30.

**[0178]** As shown in FIG. 31, in this matching manner: when the ink cartridge 40 is mounted to the mounting part 30, the transition surface 4232 of the engaging part 423 engages with the bottom portion 362z of the stylus 362, which ensures that the reaction force of the ink cartridge 40 to the stylus 362 is not sufficient to deform the stylus 362 in the -X-axis direction. When the ink cartridge 40 needs to be taken out, the user exerts a force on the ink cartridge 40 in the +Z-axis direction, so that the stylus 362 is deformed in the +X-axis direction, thereby causing the ink cartridge 40 to be detached from the mounting part 30. Compared with the matching manner shown in FIG. 30, it is the transition surface 4232 of the engaging part 423 plays an engaging role, and it is a part closest to the tip portion 362y of the first stylus 362 plays an engaging role. The ink cartridge 40 with such a structure is easier to be taken out from the mounting part 30, and the stylus 362 is not easy to be damaged.

**[0179]** Further, the transition surface 4232 of the engaging part 423 may engage with the bottom portion 362z of the stylus 362, or the horizontal surface 4233 of the engaging part 423 may engage with the bottom portion 362z of the stylus 362. The bottom portion 362z of the stylus 362 is a portion below the widest position of the first portion 362a in the X-axis direction, and thus, a portion of the first portion 362a in the -Z-axis direction of the tip portion 362y is the bottom portion 362z. The transition surface 4232 may be an arc surface or an inclined surface. Preferably, the transition surface 4232 forms an angle greater than 0 degree relative to the Z-axis direction.

**[0180]** In a normal state, in order to avoid the wafers on the chip 440 from being worn, optionally, the concave part 4404 is disposed on the third wall 40c, the concave part 4404 may accommodate at least a portion of the chip 440 and at least portion of the engaging part 423. The concave part 4404 is disposed at a position in the third wall 40c corresponding to the chip 440, and is used as an avoidance recess part for the wafer on the chip 440, which avoids the abrasion of the wafer inside the chip when the chip 440 is mounted to the third wall 40c.

**[0181]** Further, the engaging part 423 may also be multiple, for example, the number of the engaging part 423 is two, both of which are bumps partially accommodated in the concave part 4404 and extend to the plurality of recess parts 4402 of the chip 440. Two engaging parts 423 engage with the bottom portions 362z of two styluses 362, respectively. As another example, the number of the engaging parts 423 is four, all of the four engaging parts 423 are bumps partially accommodated in the concave part 4404 and extend to the four recess parts 4402 of the chip 440. The four engaging parts 423 engage with the bottom portions 362z of four styluses 362. As yet another example, the number of the engaging part 423 is two, both of two engaging part 423 are bumps partially

accommodated in the concave part 4404 and extend to the two recess parts 4402 of the chip 440. The engaging parts 423 engage with the bottom portions 362z of the styluses 362 disposed on both sides of the bottom end of the printer side-terminal part, respectively.

**[0182]** It should be noted that the engaging part 423 on the ink cartridge 40 may be a bump that is injection-molded and integrated with the ink cartridge, or the engaging part 423 may be disposed on a replaceable part, so that the same structure may match with a variety of different ink cartridge structures; the engaging part 423 may also be a bumping part mounted on the third wall 40c by means of separate sticking, clamping, etc.; in addition, it may also be an elastic bumping part mounted on the third wall 40c by means of sticking, clamping, interference fit, etc., and the elastic bumping part may be made of a material such as silicone, rubber, cork and the like.

## 20 Embodiment 5

**[0183]** FIG. 32 is a schematic view of an ink cartridge according to Embodiment 5 of the present application. No handle 470 is disposed on a third wall 40c of an ink cartridge 40, and this embodiment may also achieve the beneficial effect of the present application.

**[0184]** On the other hand, some anti-slip stripes may also be disposed on the +Z-axis side of the third wall 40c of the ink cartridge 40, which may also achieve the beneficial effect of the present application. When the ink cartridge 40 is taken out, the anti-slip stripes may prevent the relative sliding between the user's hand and the ink cartridge 40.

**[0185]** In this embodiment, a chip 440 is different from the chip of Embodiment 1. As shown in FIG. 32, a power supply terminal 446, a ground terminal 447 and a data terminal 448 of the chip 440 are disposed at the front and cross-section positions of the chip 440 respectively. The power supply terminal 446, the ground terminal 447 and the data terminal 448 of the chip 440 are in contact with a slope portion or a first vertical portion of the corresponding stylus. The remaining terminals are in contact with a tip portion of the corresponding stylus. The power supply terminal 446, the ground terminal 447 and the data terminal 448 of the chip 440 have recess parts 4402 in the -Z-axis direction. The engaging part 423 is a bump disposed on the concave part 4404 (see FIG. 29) and extends to the position of the recess part 4402. When the ink cartridge 40 is mounted to the mounting part 30, in a space between the first portions 362a of the plurality of styluses 362 and the engaging part 423, the engaging part 423 engages with the bottom portion of each stylus to prevent the ink cartridge 40 from being detached from the mounting part 30. In this structure, the same engaging part 423 may engage with the bottom portions of a plurality of styluses, so that the structure of the ink cartridge 40 is simpler, and the ink cartridge 40 may be more firmly fixed to the mounting part 30.

**[0186]** The rest is consistent with Embodiment 1.

#### Embodiment 6

**[0187]** FIG. 33 is a schematic view of an ink cartridge according to Embodiment 6 of the present application. A third wall 40c of an ink cartridge 40 is inclined and intersects with a first wall 40a. The ink cartridge is also provided with a second wall 40c2. The third wall 40c is obliquely intersected with the first wall 40a and the second wall 40c2, and is located on a corner between the first wall 40a and the second wall 40c2. A chip 440 and an engaging part 423 are disposed on the inclined third wall 40c. When the ink cartridge 40 is mounted to a mounting part 30, the chip 440 is in contact with a stylus 362, and the engaging part 423 engages with the bottom portion of the stylus to prevent the ink cartridge 40 from being detached from the mounting part.

**[0188]** A stylus 362 is shown in FIG. 33. Terminals on the chip 440 are disposed on the front surface and the cross-section surface of the chip 440, and are arranged in a row. The terminals are in contact with a slope portion of the stylus.

**[0189]** Specifically, there are only four terminals in this embodiment, and the four terminals are all disposed on the front surface and cross-section surface of the chip 440.

**[0190]** When the ink cartridge 40 is mounted to the mounting part, a first portion of the stylus is located in a space between an opposite terminal and the engaging part 423, and the engaging part 423 engages with the bottom portion of the stylus to prevent the ink cartridge 40 from being detached from the mounting part.

**[0191]** The ink cartridge 40 is also provided with a handle 470 and a second clamping part 480. The handle 470 has a first clamping part 471. The first clamping part 471 and the second clamping part 480 may each also engage with the corresponding portion on the mounting part to prevent the ink cartridge 40 from being detached from the mounting part. In this way, it may be ensured that the ink cartridge 40 may be better fixed to the mounting part.

**[0192]** When the ink cartridge 40 needs to be taken out from the mounting part, the user grasps the handle 470 so that the first clamping part 471 is detached from the mounting part; at the same time, a force in the +Z-axis direction is applied by the user to detach the engaging part 423 from the stylus; then the second clamping part 480 is detached from the mounting part, thereby taking out the ink cartridge 40 smoothly.

**[0193]** A transition surface 4232 may be an arc surface or an inclined surface. Preferably, an angle between the transition surface and a first side wall is greater than 0 degree.

**[0194]** The rest is consistent with Embodiment 1.

#### Embodiment 7

**[0195]** In an optional implementation, a third wall 40c

of an ink cartridge 40 is inclined and intersects with a first wall 40a. FIG. 34 is a schematic view of an ink cartridge according to Embodiment 7 of the present application. As shown in FIG. 34, the ink cartridge 40 is also provided with a second wall 40c2; the third wall 40c is obliquely intersected with the first wall 40a and the second wall 40c2, and is located on a corner between the first wall 40a and the second wall 40c2; the chip 440 is disposed on the third wall 40c; the third wall 40c is provide with two engaging parts 423, namely, 423a and 423b. The engaging parts 423a and 423b are disposed on the third wall 40c. When the ink cartridge 40 is mounted to the mounting part 30, the chip 440 is in contact with the stylus 362, and the engaging parts 423a and 423b engage with the bottom portion 362z of the stylus 362, thereby preventing the ink cartridge 40 from being detached from the mounting part 30.

**[0196]** A clamping part 4407 is also disposed on the ink cartridge 40, which may also engage with the corresponding portion of the mounting part to prevent the ink cartridge 40 from being detached from the mounting part.

**[0197]** The engaging part is divided into engaging parts 423a and 423b. The two engaging parts 423a and 423b are located at the same height, and their structures may be the same or different. A top surface of one engaging part 423a may be disposed as an inclined surface, and a top surface of the other engaging part 423b is disposed as a horizontal surface. Locking surfaces of two mounting plates 35 in the mounting part 30 match with the top surfaces of the two engaging parts 423 respectively, that is, the locking surface of one mounting plate 35 may be disposed as an inclined surface, and the locking surface of the other mounting plate 35 is disposed as a horizontal surface. The two engaging parts 423 of different shapes abut against the locking surfaces of the two mounting plates 35 respectively, so that the ink cartridge 40 has a certain floating space, thereby preventing the ink cartridge 40 from getting stuck in the mounting part 30.

**[0198]** The rest is consistent with Embodiment 1.

#### Embodiment 8

**[0199]** In another optional implementation, two engaging parts 423 are disposed on a third wall 40c, are located at the same height, and are of the same shape. Top surfaces of the two engaging parts 423 may be disposed as arc surfaces. Locking surfaces of two mounting plates 35 in a mounting part 30 match with the top surfaces of the two engaging parts 423 respectively, that is, the locking surfaces are arc surfaces. By abutting the two engaging parts 423 against the locking surfaces of the two mounting plates 35, the chip 440 may be electrically connected to the printer side-terminal part accurately.

**[0200]** Optionally, the top surface of one engaging part 423 is disposed as an arc surface, and the top surface of the other engaging part 423 is disposed as a plane.

**[0201]** Exemplarily, two engaging parts 423 are disposed on the third wall 40c, are located at the same

height, and are of different shapes. The top surface of one engaging part 423a may be disposed as an arc surface, and the top surface of the other engaging part 423b may be disposed as a horizontal surface. The locking surfaces of the two mounting plates 35 in the mounting part 30 match with the top surfaces of the two engaging parts 423 respectively. By abutting two engaging parts 423 of different shapes against the locking surfaces of the two mounting plates 35, the ink cartridge 40 has a certain floating space, thereby preventing the ink cartridge 40 from getting stuck in the mounting part 30. This embodiment may also achieve the beneficial effect of the present application.

**[0202]** In the description of the present application, it should be understood that directions or position relationships indicated by the terms "center", "length" "width", "thickness", "top", "bottom", "upper", "lower", "left", "right", "front", "rear", "vertical", "horizontal", "inner", "outer", "axial", "circumferential", etc. are based on directions or position relationships shown in the drawings, and are only intended to facilitate describing the present application and simplifying the description, and not to indicate or imply that the indicated position or element must have a particular orientation and be of a particular construction and operation, and therefore cannot be understood as a limitation to the present application.

**[0203]** In addition, the terms "first" and "second" are used only for descriptive purposes and cannot be understood to indicate or imply relative importance or imply the number of technical features indicated. Thus, the feature defined with "first" or "second" may explicitly or implicitly include one or more of such features. In the description of the present application, "multiple/a plurality of" means at least two, such as two, three, etc., unless otherwise clearly and specifically defined.

**[0204]** In the present application, unless otherwise clearly specified and defined, the terms "mounting", "connection", "connecting", "fixing" and the like should be understood in a broad sense. For example, it may be a fixed connection, may be a detachable connection, or may be integrated; it may be a mechanical connection, or may be an electrical connection or may communicate with each other; it may be directly connected, or indirectly connected by an intermediate medium, or allow communication within two elements or the interaction between two elements. For those of ordinary skill in the art, the specific meanings of the above terms in the present application may be understood according to the specific situation.

**[0205]** In the present application, unless otherwise expressly specified and defined, a first feature being "above" or "below" a second feature may include the first feature being in direct contact with the second feature, and may also include the first feature being not in direct contact with the second feature, and the first feature being in contact with the second feature through additional feature therebetween. Moreover, the first feature being "over", "above" and "on" the second feature includes the

first feature being directly above and diagonally above the second feature, or simply indicates that the horizontal height of the first feature is higher than that of the second feature. The first feature being "under", "below" and "beneath" the second feature includes the first feature being directly below and diagonally below the second feature, or simply indicates that the horizontal height of the first feature is less than that of the second feature.

## Claims

1. An ink cartridge (40) for detachably mounted in a printing apparatus, comprising a cartridge body (420), an ink outlet (430) located on a first wall (40a) of the cartridge body (420) and a chip (440) located on a third wall (40c) intersecting with the first wall (40a), wherein

the ink cartridge (40) further comprises at least one positioning part (450);

the at least one positioning part (450) is disposed on a side wall of the cartridge body (420) intersecting with the third wall (40c) where the chip (440) is disposed; and

the at least one positioning part (450) has a positioning boss (452), and a distance from the positioning boss to the first wall (40a) of the cartridge body (420) is less than or equal to a maximum distance from the chip (440) to the first wall (40a) of the cartridge body (420), the distance from the positioning boss to the first wall (40a) of the cartridge body (420) is greater than or equal to a minimum distance from the chip (440) to the first wall (40a) of the cartridge body (420), thereby preventing the ink cartridge (40) from detaching from a mounting part (30) of the printing apparatus in a vertical direction;

the chip (440) comprises a plurality of the terminals;

the plurality of the terminals are disposed in a plurality of rows, in the plurality of rows of terminals, the lowermost row of terminals are closest to the first wall (40a), and the uppermost row of terminals are farthest from the first wall (40a), a distance from the positioning boss to the first wall (40a) is less than or equal to a distance from the uppermost row of terminals to the first wall (40a), the distance from the positioning boss to the first wall (40a) is greater than or equal to a distance from the lowermost row of terminals to the first wall (40a).

2. The ink cartridge (40) according to claim 1, wherein the plurality of terminals are provided with respective contact parts connected with styluses in the printing apparatus, the contact parts are arranged in a plurality of rows, the lowermost row of contact parts are

closest to the first wall (40a), the uppermost row of contact parts are farthest from the first wall (40a), the distance from the positioning boss to the first wall (40a) is less than or equal to a distance from the uppermost row of contact parts to the first wall (40a), the distance from the positioning boss to the first wall (40a) is greater than or equal to a distance from the lowermost row of contact parts to the first wall (40a).

3. The ink cartridge (40) according to claim 1 or 2, wherein

the cartridge body (420) further comprises: a second wall (40b) disposed opposite to the first wall (40a), a fourth wall (40d) disposed opposite to the third wall (40c), and a fifth wall (40e) and a sixth wall (40f) that are disposed opposite to each other, located between the first wall (40a) and the second wall (40b) and each intersect with the third wall (40c) and the fourth wall (40d), the third wall (40c) and the fourth wall (40d) are located between the first wall (40a) and the second wall (40b), and the first wall (40a), the second wall (40b), the third wall (40c), the fourth wall (40d), the fifth wall (40e) and the sixth wall (40f) enclose the cartridge body (420) provided with an ink chamber (220) therein;

the ink outlet (430) is located on the first wall (40a);

the chip (440) is located on the third wall (40c); and

the positioning boss is located on the fifth wall (40e) and/or the sixth wall (40f).

4. The ink cartridge (40) according to claim 1, wherein the plurality of the terminals are disposed in at least three rows, in the at least three rows of terminals, the lowermost row of terminals are closest to the first wall (40a), and the uppermost row of terminals are farthest from the first wall (40a), a distance from the positioning boss to the first wall (40a) is less than a distance from contact parts of the uppermost row of terminals to the first wall (40a), the distance from the positioning boss to the first wall (40a) is greater than a distance from contact parts of the second row of terminals to the first wall (40a), and the distance from the positioning boss to the first wall (40a) is greater than a distance from contact parts of the lowermost row of terminals to the first wall (40a).

5. The ink cartridge according to claim 4, wherein the distance from the positioning boss to the first wall is less than a distance from the uppermost row of terminals to the first wall, the distance from the positioning boss to the first wall is greater than a distance from the second row of terminals to the first wall, the distance from the positioning boss to the first wall is greater than a distance from the lowermost row of

terminals to the first wall.

6. The ink cartridge (40) according to any one of claims 1-4, wherein the chip (440) further comprises a substrate on which two notches are disposed; in a direction of the fifth wall (40e) pointing to the sixth wall (40f), the lowermost row of terminals are each located between the two notches, the notches are located on an end of the substrate close to the first wall (40a), and in a direction of the first wall (40a) pointing to the second wall (40b), the lowermost row of terminals at least partially coincide with the notches.
7. The ink cartridge (40) according to claim 6, wherein the two notches are respectively located on sides of the chip (440) close to the fifth wall (40e) and the sixth wall (40f), the notches are located at positions below the second row of terminals, and the notch is capable of accommodating at least one stylus of the printing apparatus.
8. The ink cartridge (40) according to any one of claims 1-5, wherein the terminals further have extension terminals, and when viewed in a direction of the first wall (40a) pointing to the second wall (40b), at least a part of the extension terminals are disposed within a range of the positioning part (450).
9. The ink cartridge (40) according to any one of claims 1-3, wherein the plurality of terminals are arranged in four rows, which sequentially are a first row (L1), a second row (L2), a third row (L3) and a fourth row (L4) in a direction away from the first wall (40a), the positioning boss is disposed on a side of the first row (L1) away from the first wall (40a), and/or the positioning boss is disposed on a side of the fourth row (L4) close to the first wall (40a); the positioning boss is disposed on a side of the second row (L2) away from the first wall (40a), and/or the positioning boss is disposed on a side of the third row (L3) close to the first wall (40a).
10. The ink cartridge (40) according to any one of claims 1-8, wherein the positioning part (450) further comprises a positioning plate and an elastic arm; the positioning plate is disposed on at least one side wall that is disposed between a top surface and the first wall (40a) of the cartridge body and intersects with a side wall on which the chip (440) is located, and the positioning boss is located on the positioning plate; one end of the elastic arm is connected with the positioning plate, and the other end of the elastic arm is connected with the positioning boss.
11. The ink cartridge (40) according to any one of claims 1-8, wherein two positioning parts (450) are comprised;

one positioning part (450) is disposed on a side of the sixth wall (40f) close to the third wall (40c), and the other positioning part (450) is disposed on a side of the fifth wall (40e) close to the third wall (40c), and the two positioning parts (450) are disposed opposite to each other.

12. The ink cartridge (40) according to any one of claims 1-8, further comprising a handheld part disposed on the third wall (40c), wherein the handheld part is an anti-slip stripe (461) that increases friction, a movable member with a certain distance from a body of ink cartridge (40), or a bulge fixed on the body of the ink cartridge (40).

13. A printing apparatus comprising a mounting part (30) and the ink cartridge as claimed in any one of claims 1-12, wherein

the mounting part (30) has a mounting chamber (320), and comprises at least two mounting plates, at least one side-terminal part and an ink supply part (330), and the ink supply part (330) is disposed in the mounting chamber (320) and is configured for docking with the ink outlet (430); the mounting plates are disposed on a side wall of the mounting chamber (320), the side-terminal part is disposed between two mounting plates, and the two mounting plates are provided with respective bumps at a side toward the side-terminal part, and the bumps are configured for clamping with the positioning part (450) of the ink cartridge; and

the side-terminal part comprises a base and a plurality of styluses, the plurality of styluses (362) are disposed on the base and are arranged in a plurality of rows, and the bumps are located between the plurality of rows of styluses (362).

### Patentansprüche

1. Tintenpatrone (40) zur abnehmbaren Anbringung in einer Druckvorrichtung, mit einem Patronenkörper (420), einem Tintenauslass (430), der an einer ersten Wand (40a) des Patronenkörpers (420) angeordnet ist, und einem Chip (440), der an einer dritten Wand (40c) angeordnet ist, die die erste Wand (40a) schneidet, wobei die Tintenpatrone (40) ferner mindestens ein Positionierungsteil (450) umfasst;

das mindestens eine Positionierungsteil (450) ist an einer Seitenwand des Patronenkörpers (420) angeordnet, die sich mit der dritten Wand (40c) schneidet, an der der Chip (440) angeordnet ist; und

das mindestens eine Positionierungsteil (450)

weist einen Positionierungsvorsprung (452) auf, und ein Abstand von dem Positionierungsvorsprung zu der ersten Wand (40a) des Patronenkörpers (420) ist kleiner als oder gleich einem maximalen Abstand von dem Chip (440) zu der ersten Wand (40a) des Patronenkörpers (420), der Abstand von dem Positionierungsvorsprung zu der ersten Wand (40a) des Patronenkörpers (420) ist größer als oder gleich einem minimalen Abstand von dem Chip (440) zu der ersten Wand (40a) des Patronenkörpers (420), wodurch verhindert wird, dass sich die Tintenpatrone (40) von einem Befestigungsteil (30) der Druckvorrichtung in vertikaler Richtung löst; der Chip (440) umfasst eine Mehrzahl von Anschlüssen; die Mehrzahl der Anschlüsse ist in einer Mehrzahl von Reihen angeordnet sind, wobei in der Mehrzahl von Reihen von Anschlüssen die unterste Reihe von Anschlüssen der ersten Wand (40a) am nächsten ist und die oberste Reihe von Anschlüssen am weitesten von der ersten Wand (40a) entfernt ist, ein Abstand von dem Positionierungsvorsprung zu der ersten Wand (40a) kleiner als oder gleich einem Abstand von der obersten Reihe von Anschlüssen zu der ersten Wand (40a) ist, und der Abstand von dem Positionierungsvorsprung zu der ersten Wand (40a) größer als oder gleich einem Abstand von der untersten Reihe von Anschlüssen zu der ersten Wand (40a) ist.

2. Tintenpatrone (40) nach Anspruch 1, wobei die mehreren Anschlüsse mit jeweiligen Kontaktteilen versehen sind, die mit Taststiften in der Druckvorrichtung verbunden sind, wobei die Kontaktteile in mehreren Reihen angeordnet sind, wobei die unterste Reihe von Kontaktteilen der ersten Wand (40a) am nächsten ist, wobei die oberste Reihe von Kontaktteilen am weitesten von der ersten Wand (40a) entfernt ist, wobei der Abstand von dem Positionierungsvorsprung zu der ersten Wand (40a) kleiner als oder gleich einem Abstand von der obersten Reihe der Kontaktteile zu der ersten Wand (40a) ist, der Abstand von dem Positionierungsvorsprung zu der ersten Wand (40a) größer als oder gleich einem Abstand von der untersten Reihe von Kontaktteilen zu der ersten Wand (40a) ist.

3. Tintenpatrone (40) nach Anspruch 1 oder 2, wobei der Patronenkörper (420) ferner umfasst: eine zweite Wand (40b), die der ersten Wand (40a) gegenüberliegend angeordnet ist, eine vierte Wand (40d), die der dritten Wand (40c) gegenüberliegend angeordnet ist, und eine fünfte Wand (40e) und eine sechste Wand (40f), die einander gegenüberliegend angeordnet sind, sich zwischen der ersten Wand (40a) und der zweiten Wand (40b) befinden und sich

- jeweils mit der dritten Wand (40c) und der vierten Wand (40d) kreuzen, die dritte Wand (40c) und die vierte Wand (40d) sind zwischen der ersten Wand (40a) und der zweiten Wand (40b) angeordnet, und die erste Wand (40a), die zweite Wand (40b), die dritte Wand (40c), die vierte Wand (40d), die fünfte Wand (40e) und die sechste Wand (40f) umschließen den Patronenkörper (420), der mit einer Tinten­kammer (220) darin versehen ist; wobei sich der Tintenauslass (430) an der ersten Wand (40a) befindet und der Chip (440) sich an der dritten Wand (40c) befindet; und der Positionierungsvorsprung sich an der fünften Wand (40e) und/oder der sechsten Wand (40f) befindet.
4. Tintenpatrone (40) nach Anspruch 1, wobei die Mehrzahl der Anschlüsse in mindestens drei Reihen angeordnet ist, wobei in den mindestens drei Reihen von Anschlüssen die unterste Reihe von Anschlüssen der ersten Wand (40a) am nächsten ist und die oberste Reihe von Anschlüssen am weitesten von der ersten Wand (40a) entfernt ist, ein Abstand von dem Positionierungsvorsprung zu der ersten Wand (40a) geringer ist als ein Abstand von Kontaktteilen der obersten Reihe von Anschlüssen zu der ersten Wand (40a), wobei der Abstand von dem Positionierungsvorsprung zu der ersten Wand (40a) größer ist als ein Abstand von Kontaktteilen der zweiten Reihe von Anschlüssen zu der ersten Wand (40a), und der Abstand von dem Positionierungsvorsprung zu der ersten Wand (40a) größer ist als ein Abstand von Kontaktteilen der untersten Reihe von Anschlüssen zu der ersten Wand (40a).
5. Tintenpatrone nach Anspruch 4, wobei der Abstand von dem Positionierungsvorsprung zu der ersten Wand geringer ist als ein Abstand von der obersten Reihe von Anschlüssen zu der ersten Wand, der Abstand von dem Positionierungsvorsprung zu der ersten Wand größer ist als ein Abstand von der zweiten Reihe von Anschlüssen zu der ersten Wand, der Abstand von dem Positionierungsvorsprung zu der ersten Wand größer ist als ein Abstand von der untersten Reihe von Anschlüssen zu der ersten Wand.
6. Tintenpatrone (40) nach einem der Ansprüche 1-4, wobei der Chip (440) ferner ein Substrat umfasst, auf dem zwei Kerben angeordnet sind; wobei in einer Richtung der fünften Wand (40e), die zur sechsten Wand (40f) zeigt, die unterste Reihe von Anschlüssen jeweils zwischen den beiden Kerben angeordnet ist, wobei die Kerben an einem Ende des Substrats nahe der ersten Wand (40a) angeordnet sind, und wobei in einer Richtung der ersten Wand (40a), die zur zweiten Wand (40b) zeigt, die unterste Reihe von Anschlüssen zumindest teilweise mit den Kerben zusammenfällt.
7. Tintenpatrone (40) nach Anspruch 6, wobei die beiden Kerben jeweils auf Seiten des Chips (440) nahe der fünften Wand (40e) und der sechsten Wand (40f) angeordnet sind, wobei die Kerben an Positionen unterhalb der zweiten Reihe von Anschlüssen angeordnet sind und die Kerbe in der Lage ist, mindestens einen Stift der Druckvorrichtung aufzunehmen.
8. Tintenpatrone (40) nach einem der Ansprüche 1 bis 5, wobei die Anschlüsse ferner Verlängerungsanschlüsse aufweisen und bei Betrachtung in einer Richtung von der ersten Wand (40a) zur zweiten Wand (40b) mindestens ein Teil der Verlängerungsanschlüsse innerhalb eines Bereichs des Positionierungsteils (450) angeordnet ist.
9. Tintenpatrone (40) nach einem der Ansprüche 1 bis 3, wobei die Mehrzahl von Anschlüssen in vier Reihen angeordnet ist, die nacheinander eine erste Reihe (L1), eine zweite Reihe (L2), eine dritte Reihe (L3) und eine vierte Reihe (L4) in einer Richtung weg von der ersten Wand (40a) bilden, wobei der Positionierungsvorsprung auf einer Seite der ersten Reihe (L1) weg von der ersten Wand (40a) angeordnet ist, und/oder wobei der Positionierungsvorsprung auf einer Seite der vierten Reihe (L4) nahe der ersten Wand (40a) angeordnet ist; wobei der Positionierungsvorsprung auf einer von der ersten Wand (40a) entfernten Seite der zweiten Reihe (L2) angeordnet ist, und/oder wobei der Positionierungsvorsprung auf einer Seite der dritten Reihe (L3) nahe der ersten Wand (40a) angeordnet ist.
10. Tintenpatrone (40) nach einem der Ansprüche 1-8, wobei das Positionierungsteil (450) ferner eine Positionierungsplatte und einen elastischen Arm umfasst; wobei die Positionierungsplatte an mindestens einer Seitenwand angeordnet ist, die zwischen einer oberen Fläche und der ersten Wand (40a) des Patronenkörpers angeordnet ist und sich mit einer Seitenwand schneidet, an der der Chip (440) angeordnet ist, und wobei der Positionierungsvorsprung an der Positionierungsplatte angeordnet ist; ein Ende des elastischen Arms ist mit der Positionierungsplatte verbunden und das andere Ende des elastischen Arms ist mit dem Positionierungsvorsprung verbunden.
11. Tintenpatrone (40) nach einem der Ansprüche 1-8, wobei zwei Positionierungsteile (450) vorgesehen sind; wobei ein Positionierungsteil (450) auf einer Seite der sechsten Wand (40f) nahe der dritten Wand (40c) angeordnet ist, und das andere Positionierungsteil (450) auf einer Seite der fünften Wand (40e) nahe der dritten Wand (40c) angeordnet ist, und die beiden Positionierungsteile (450) einander gegenüberliegend angeordnet sind.

12. Tintenpatrone (40) nach einem der Ansprüche 1 bis 8, ferner umfassend ein an der dritten Wand (40c) angeordnetes Handhabungsteil, wobei das Handhabungsteil ein Antirutschstreifen (461) ist, der die Reibung erhöht, ein bewegliches Element mit einem bestimmten Abstand von einem Körper der Tintenpatrone (40) oder eine am Körper der Tintenpatrone (40) befestigte Ausbuchtung.
13. Druckgerät mit einem Montageteil (30) und der Tintenpatrone nach einem der Ansprüche 1-12, wobei das Montageteil (30) eine Montagekammer (320) aufweist und mindestens zwei Montageplatten, mindestens ein Seitenanschlussteil und ein Tintenzufuhrteil (330) umfasst, und wobei das Tintenzufuhrteil (330) in der Montagekammer (320) angeordnet ist und zum Andocken an den Tintenauslass (430) ausgebildet ist; wobei die Montageplatten an einer Seitenwand der Montagekammer (320) angeordnet sind, das Seitenanschlussteil zwischen zwei Montageplatten angeordnet ist, und die zwei Montageplatten mit entsprechenden Erhebungen an einer Seite in Richtung des Seitenanschlussteils versehen sind, und die Erhebungen zum Klemmen mit dem Positionierungsteil (450) der Tintenpatrone konfiguriert sind; und der Seitenanschlussteil eine Basis und eine Mehrzahl von Stiften umfasst, die Mehrzahl von Stiften (362) auf der Basis angeordnet ist und in einer Mehrzahl von Reihen angeordnet ist, und die Höcker zwischen der Mehrzahl von Reihen von Stiften (362) angeordnet sind.

## Revendications

1. Cartouche d'encre (40) pour montage amovible dans un appareil d'impression, comprenant un corps de cartouche (420), une sortie d'encre (430) située sur une première paroi (40a) du corps de cartouche (420) et une puce (440) située sur une troisième paroi (40c) croisant la première paroi (40a), en ce que la cartouche d'encre (40) comprend en outre au moins une partie de positionnement (450) ;
- ladite partie de positionnement (450) est disposée sur une paroi latérale du corps de cartouche (420) croisant la troisième paroi (40c) où la puce (440) est disposée ; et
- ladite partie de positionnement (450) a un bossage de positionnement (452), et une distance entre le bossage de positionnement et la première paroi (40a) du corps de cartouche (420) est inférieure ou égale à une distance maximale de la puce (440) à la première paroi (40a) du corps de cartouche (420), la distance entre le bossage de positionnement et la première paroi (40a) du corps de cartouche (420) est supérieure ou égale à une distance minimale de la puce

(440) à la première paroi (40a) du corps de cartouche (420), ce qui empêche la cartouche d'encre (40) de se détacher d'une partie de montage (30) de l'appareil d'impression dans un sens vertical ;

la puce (440) comprend une pluralité de bornes ; la pluralité de bornes sont disposées dans une pluralité de rangées, dans la pluralité de rangées de bornes, la rangée la plus basse de bornes est la plus proche de la première paroi (40a), et la rangée la plus haute de bornes est la plus éloignée de la première paroi (40a), une distance entre le bossage de positionnement et la première paroi (40a) est inférieure ou égale à une distance de la rangée la plus haute de bornes à la première paroi (40a), la distance entre le bossage de positionnement et la première paroi (40a) est supérieure ou égale à une distance de la rangée la plus basse de bornes à la première paroi (40a).

2. Cartouche d'encre (40) selon la revendication 1, en ce que la pluralité de bornes comportent des parties de contact respectives reliées à des stylets dans l'appareil d'impression, les parties de contact sont disposées dans une pluralité de rangées, la rangée la plus basse des parties de contact étant la plus proche de la première paroi (40a), la rangée la plus haute des parties de contact étant la plus éloignée de la première paroi (40a), la distance entre le bossage de positionnement et la première paroi (40a) est inférieure ou égale à une distance de la rangée la plus haute des parties de contact à la première paroi (40a), la distance entre le bossage de positionnement et la première paroi (40a) est supérieure ou égale à une distance de la rangée la plus basse des parties de contact à la première paroi (40a).
3. Cartouche d'encre (40) selon la revendication 1 ou 2, en ce que

le corps de cartouche (420) comprend en outre une deuxième paroi (40b) opposée à la première paroi (40a), une quatrième paroi (40d) opposée à la troisième paroi (40c), et une cinquième paroi (40e) et une sixième paroi (40f) qui sont opposées l'une à l'autre, situées entre la première paroi (40a) et la deuxième paroi (40b) et coupant chacune la troisième paroi (40c) et la quatrième paroi (40d), la troisième paroi (40c) et la quatrième paroi (40d) sont situées entre la première paroi (40a) et la deuxième paroi (40b), et la première paroi (40a), la deuxième paroi (40b), la troisième paroi (40c), la quatrième paroi (40d), la cinquième paroi (40e) et la sixième paroi (40f) entourent le corps de cartouche (420) comportant une chambre d'encre (220) ;

la sortie d'encre (430) est située sur la première

- paroi (40a) ;  
la puce (440) est située sur la troisième paroi (40c) ; et  
le bossage de positionnement est situé sur la cinquième paroi (40e) et/ou la sixième paroi (40f).
4. Cartouche d'encre (40) selon la revendication 1, en ce que  
la pluralité de bornes sont disposées dans au moins trois rangées, dans lesdites trois rangées de bornes, la rangée la plus basse de bornes est la plus proche de la première paroi (40a), et la rangée la plus haute de bornes est la plus éloignée de la première paroi (40a), une distance entre le bossage de positionnement et la première paroi (40a) est inférieure à une distance des parties de contact de la rangée la plus haute de bornes à la première paroi (40a), la distance entre le bossage de positionnement et la première paroi (40a) est supérieure à une distance des parties de contact de la deuxième rangée de bornes à la première paroi (40a), et la distance entre le bossage de positionnement et la première paroi (40a) est supérieure à une distance des parties de contact de la rangée la plus basse de bornes à la première paroi (40a).
5. Cartouche d'encre selon la revendication 4, en ce que la distance entre le bossage de positionnement et la première paroi est inférieure à une distance de la rangée la plus haute de bornes à la première paroi, la distance entre le bossage de positionnement et la première paroi est supérieure à une distance de la deuxième rangée de bornes à la première paroi, la distance entre le bossage de positionnement et la première paroi est supérieure à une distance de la rangée la plus basse de bornes à la première paroi.
6. Cartouche d'encre (40) selon l'une des revendications 1 à 4, en ce que la puce (440) comprend en outre un substrat sur lequel sont disposées deux encoches ;  
dans une direction de la cinquième paroi (40e) pointant vers la sixième paroi (40f), chaque rangée la plus basse de bornes est située entre les deux encoches, les encoches sont situées à une extrémité du substrat près de la première paroi (40a), et dans une direction de la première paroi (40a) pointant vers la deuxième paroi (40b), la rangée la plus basse de bornes coïncide au moins partiellement avec les encoches.
7. Cartouche d'encre (40) selon la revendication 6, en ce que les deux encoches sont respectivement situées sur des côtés de la puce (440) près de la cinquième paroi (40e) et de la sixième paroi (40f), les encoches sont situées à des positions au-dessous de la deuxième rangée de bornes, et l'encoche peut
- loger au moins un stylet de l'appareil d'impression.
8. Cartouche d'encre (40) selon l'une des revendications 1 à 5, en ce que les bornes ont en outre des bornes d'extension et, vu dans une direction de la première paroi (40a) pointant vers la deuxième paroi (40b), au moins une partie des bornes d'extension est disposée à l'intérieur d'une plage de la partie de positionnement (450).
9. Cartouche d'encre (40) selon l'une des revendications 1 à 3, en ce que la pluralité de bornes sont disposées en quatre rangées, qui sont séquentiellement une première rangée (L1), une deuxième rangée (L2), une troisième rangée (L3) et une quatrième rangée (L4) dans une direction opposée à la première paroi (40a), le bossage de positionnement est disposé sur un côté de la première rangée (L1) opposé à la première paroi (40a), et/ou le bossage de positionnement est disposé sur un côté de la quatrième rangée (L4) près de la première paroi (40a) ; le bossage de positionnement est disposé sur un côté de la deuxième rangée (L2) opposé à la première paroi (40a), et/ou le bossage de positionnement est disposé sur un côté de la troisième rangée (L3) près de la première paroi (40a).
10. Cartouche d'encre (40) selon l'une des revendications 1 à 8, en ce que la partie de positionnement (450) comprend en outre une plaque de positionnement et un bras élastique ;  
la plaque de positionnement est disposée sur au moins une paroi latérale qui est disposée entre une surface supérieure et la première paroi (40a) du corps de cartouche et croise une paroi latérale sur laquelle est située la puce (440), et le bossage de positionnement est situé sur la plaque de positionnement ; une extrémité du bras élastique est reliée à la plaque de positionnement, et l'autre extrémité du bras élastique est reliée au bossage de positionnement.
11. Cartouche d'encre (40) selon l'une des revendications 1 à 8, en ce que deux parties de positionnement (450) sont comprises ;  
une partie de positionnement (450) est disposée sur un côté de la sixième paroi (40f) près de la troisième paroi (40c), et l'autre partie de positionnement (450) est disposée sur un côté de la cinquième paroi (40e) près de la troisième paroi (40c), et les deux parties de positionnement (450) sont opposées l'une à l'autre.
12. Cartouche d'encre (40) selon l'une des revendications 1 à 8, comprenant en outre une partie manuelle disposée sur la troisième paroi (40c), en ce que la partie manuelle est une bande antidérapante (461) qui augmente la friction, un élément mobile à une

distance définie d'un corps de la cartouche d'encre (40), ou un renflement fixé sur le corps de la cartouche d'encre (40).

13. Appareil d'impression comprenant une partie de montage (30) et la cartouche d'encre selon l'une des revendications 1 à 12, en ce que

la partie de montage (30) a une chambre de montage (320), et comprend au moins deux plaques de montage, au moins une partie de borne latérale et une partie d'alimentation en encre (330), et la partie d'alimentation en encre (330) est disposée dans la chambre de montage (320) et est conçue pour s'amarrer à la sortie d'encre (430) ;

les plaques de montage sont disposées sur une paroi latérale de la chambre de montage (320), la partie de borne latérale est disposée entre deux plaques de montage, et les deux plaques de montage comportent des bosses respectives sur un côté vers la partie de borne latérale, et les bosses sont conçues pour être assemblées par serrage à la partie de positionnement (450) de la cartouche d'encre ;

la partie de borne latérale comprend une base et une pluralité de stylets, la pluralité de stylets (362) sont disposés sur la base et sont arrangés en une pluralité de rangées, et les bosses sont situées entre la pluralité de rangées de stylets (362).

35

40

45

50

55

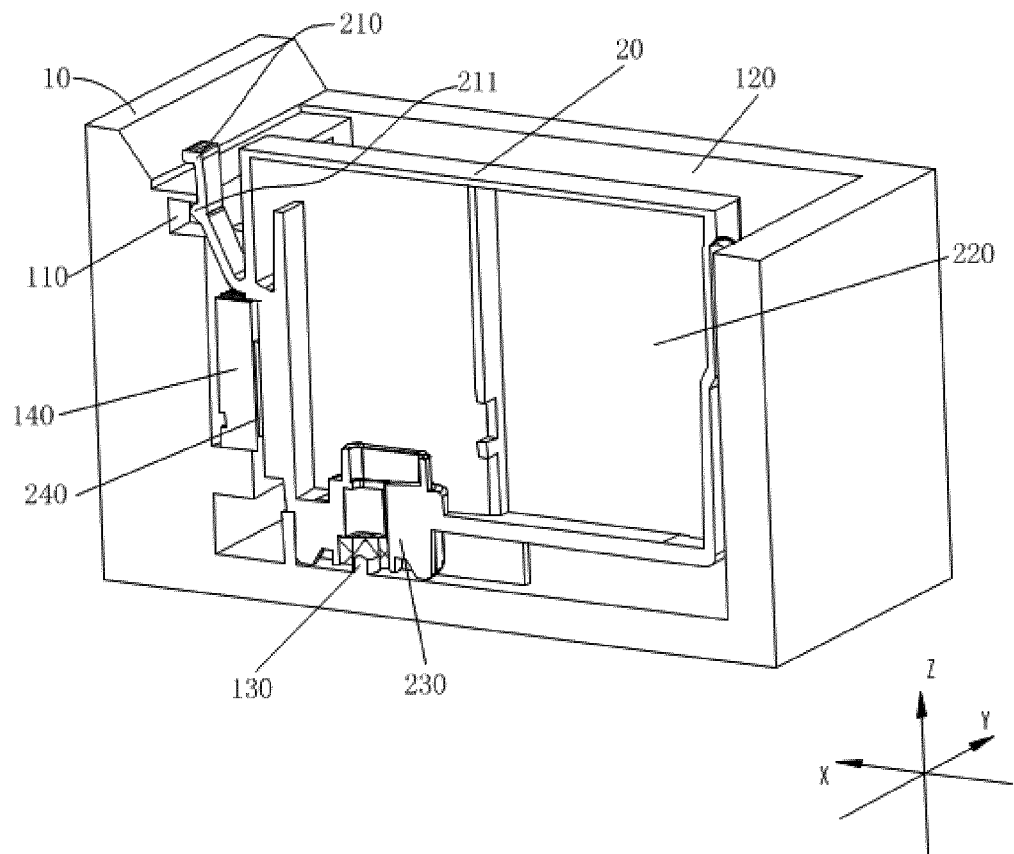

FIG. 1

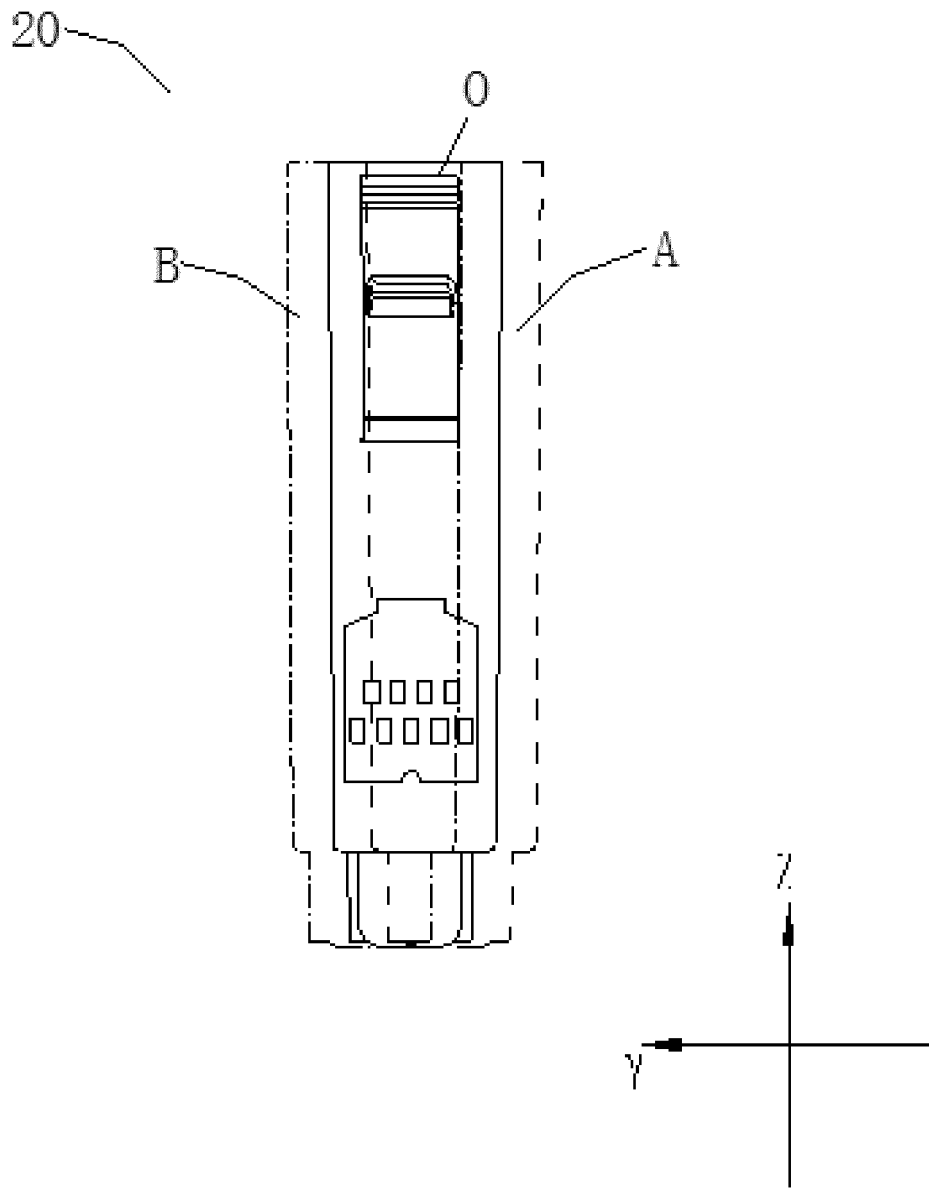

FIG. 2

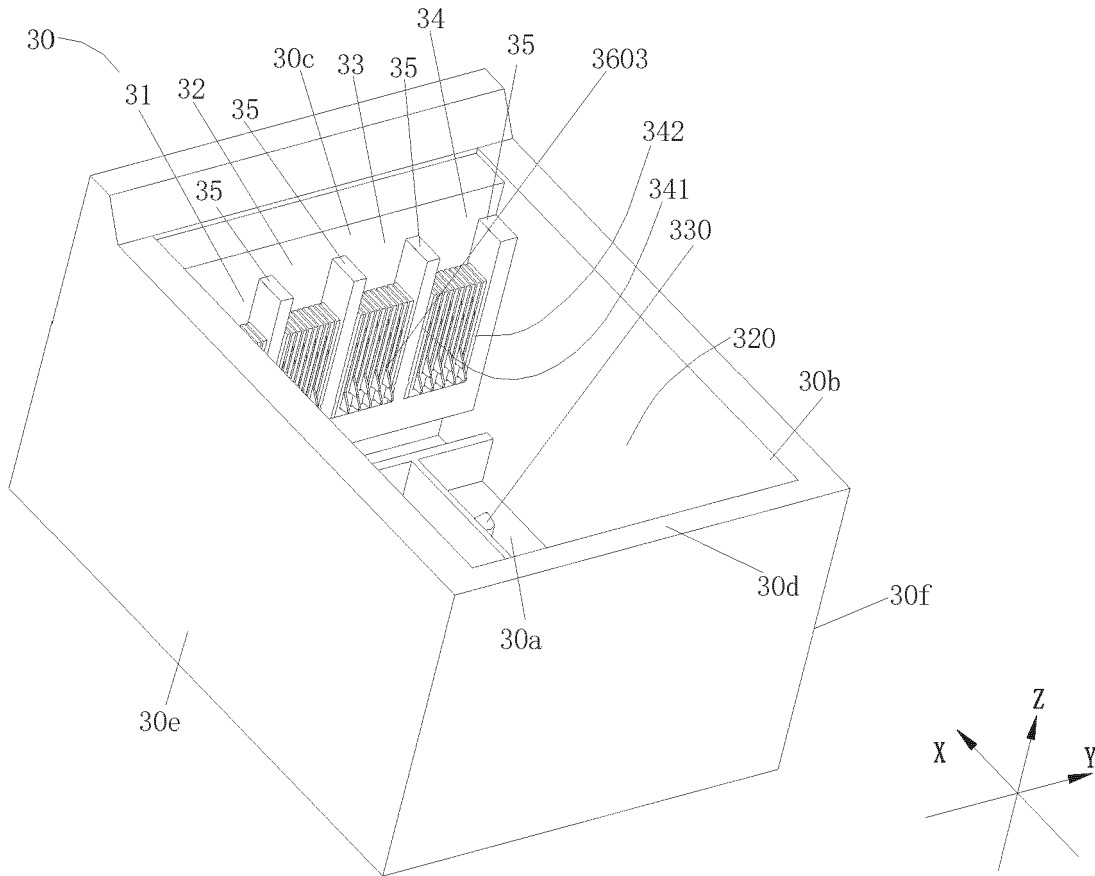

FIG. 3

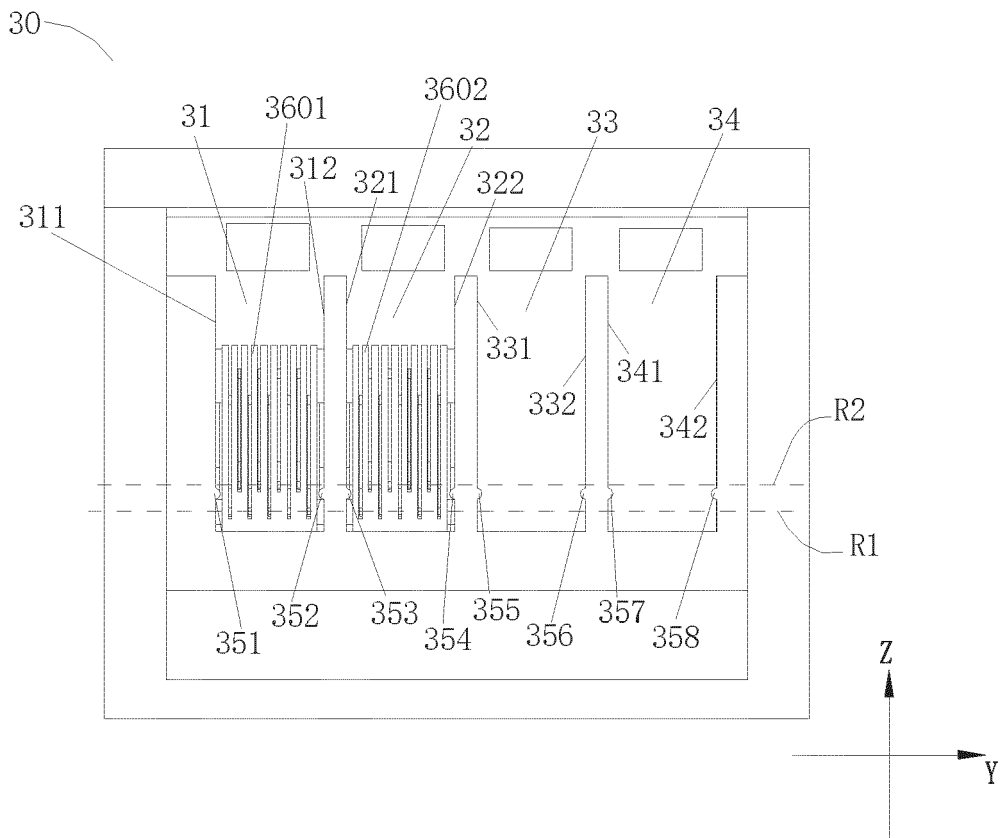

FIG. 4

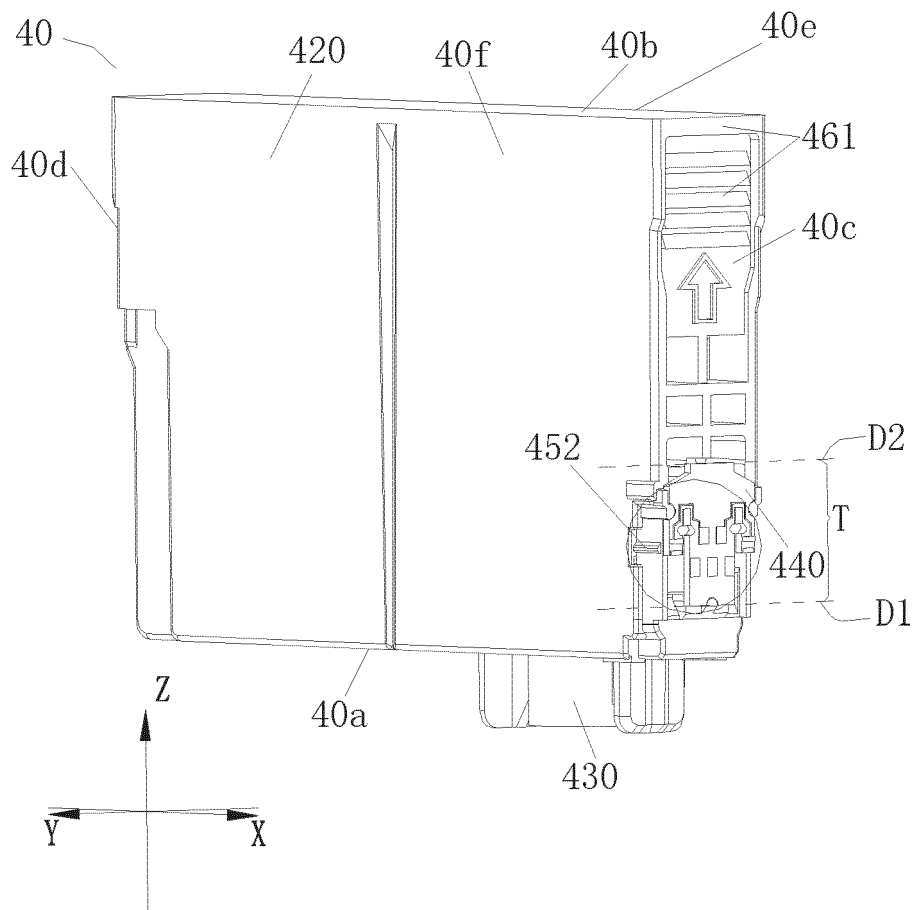

FIG. 5

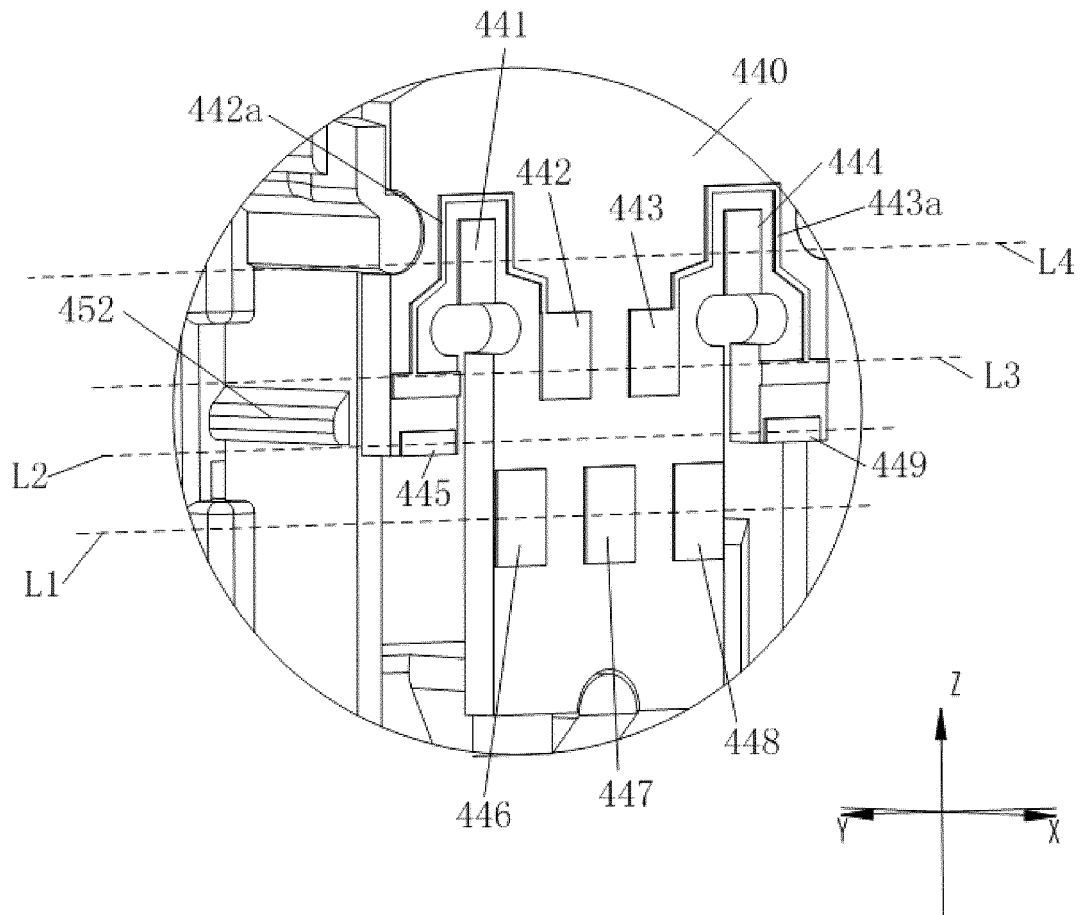

FIG. 6

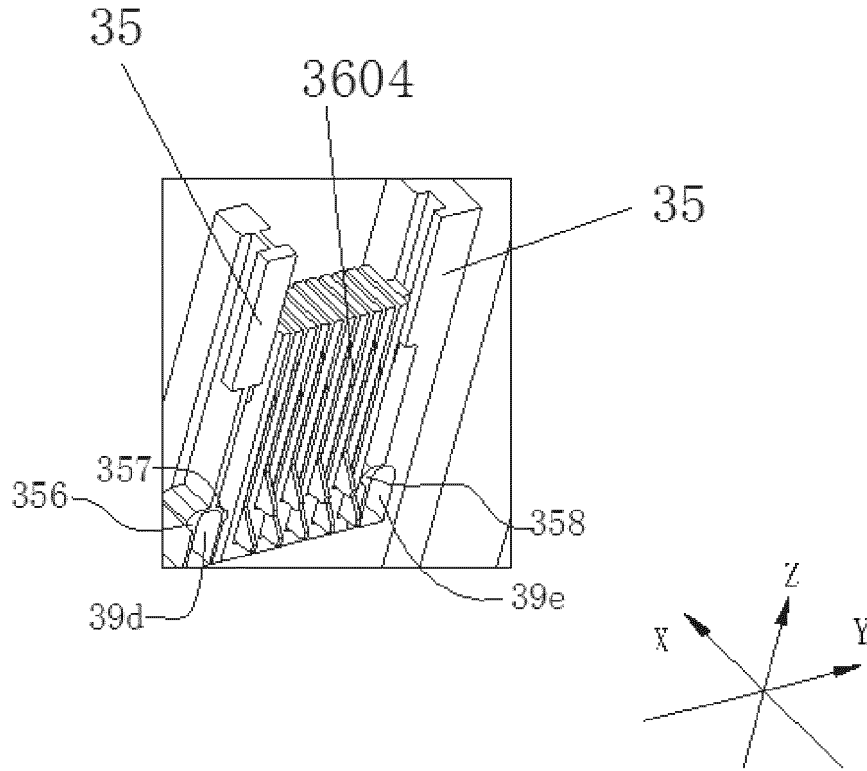

FIG. 7

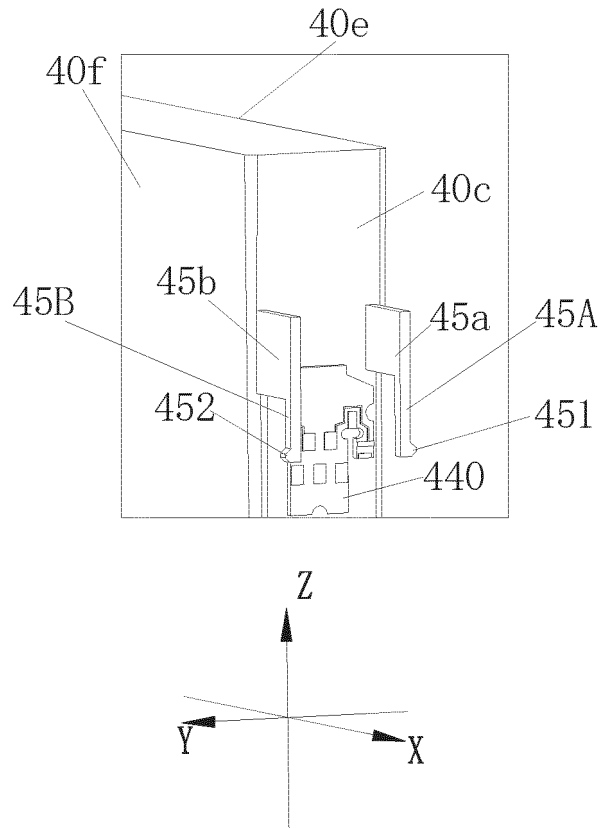

FIG. 8

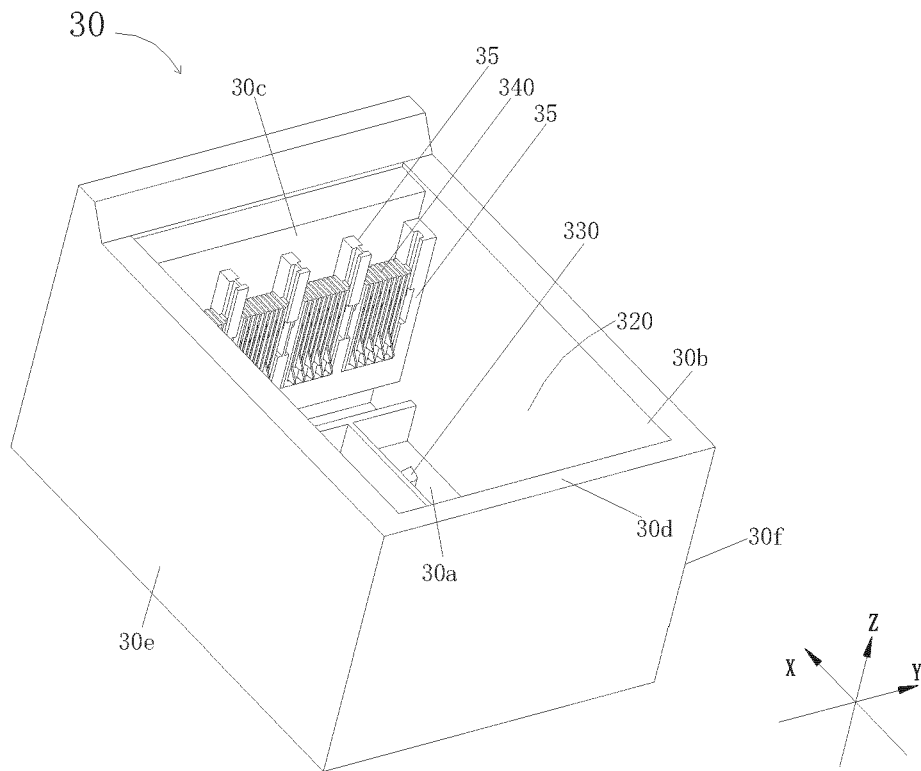

FIG. 9

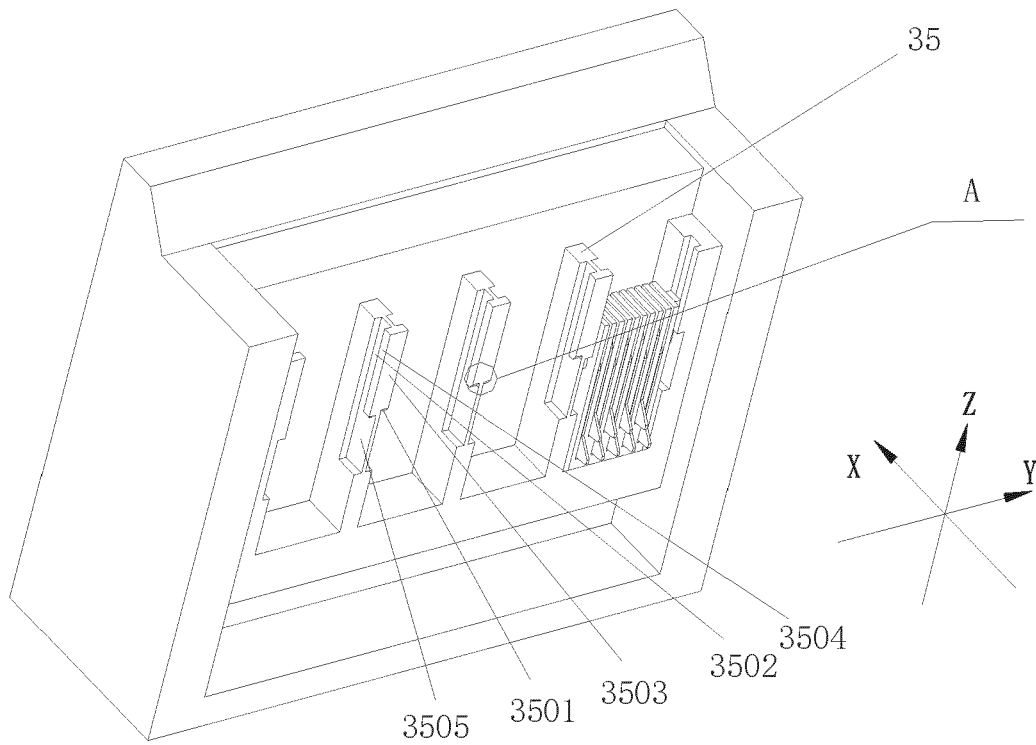

FIG. 10

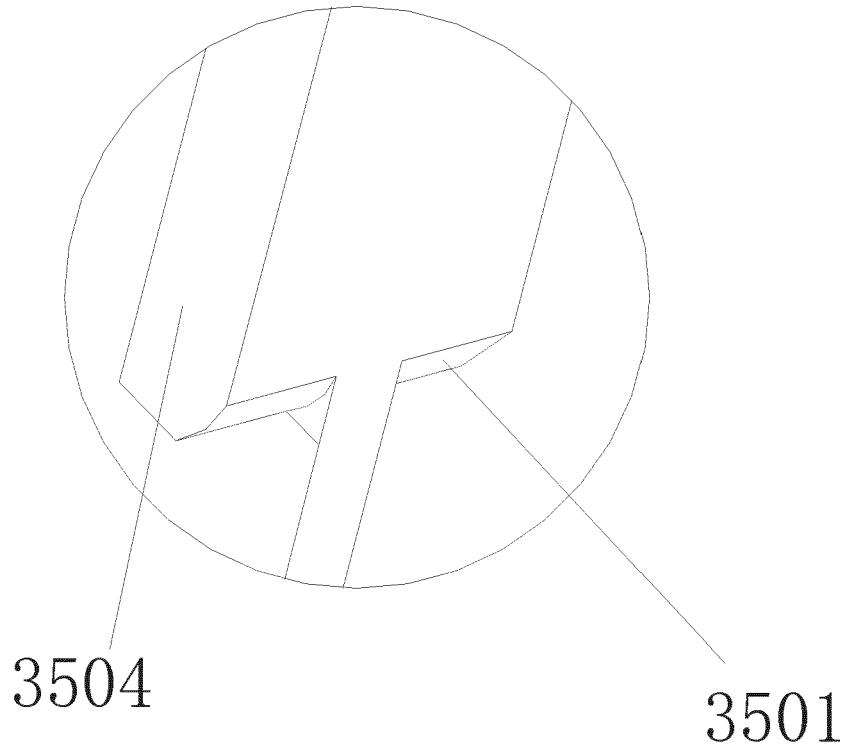

FIG. 11

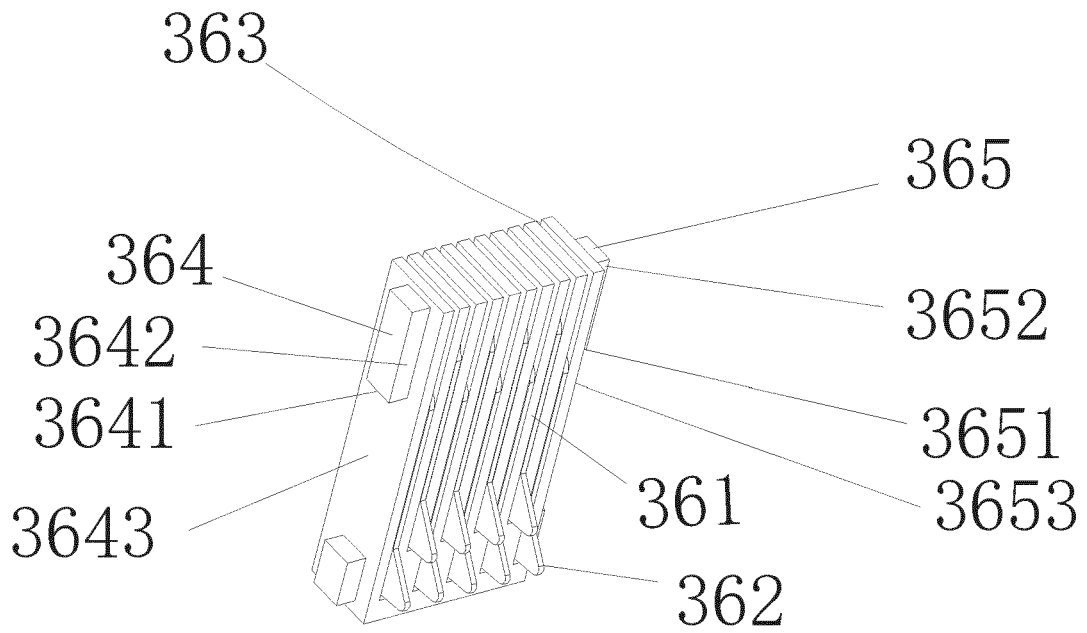

FIG. 12

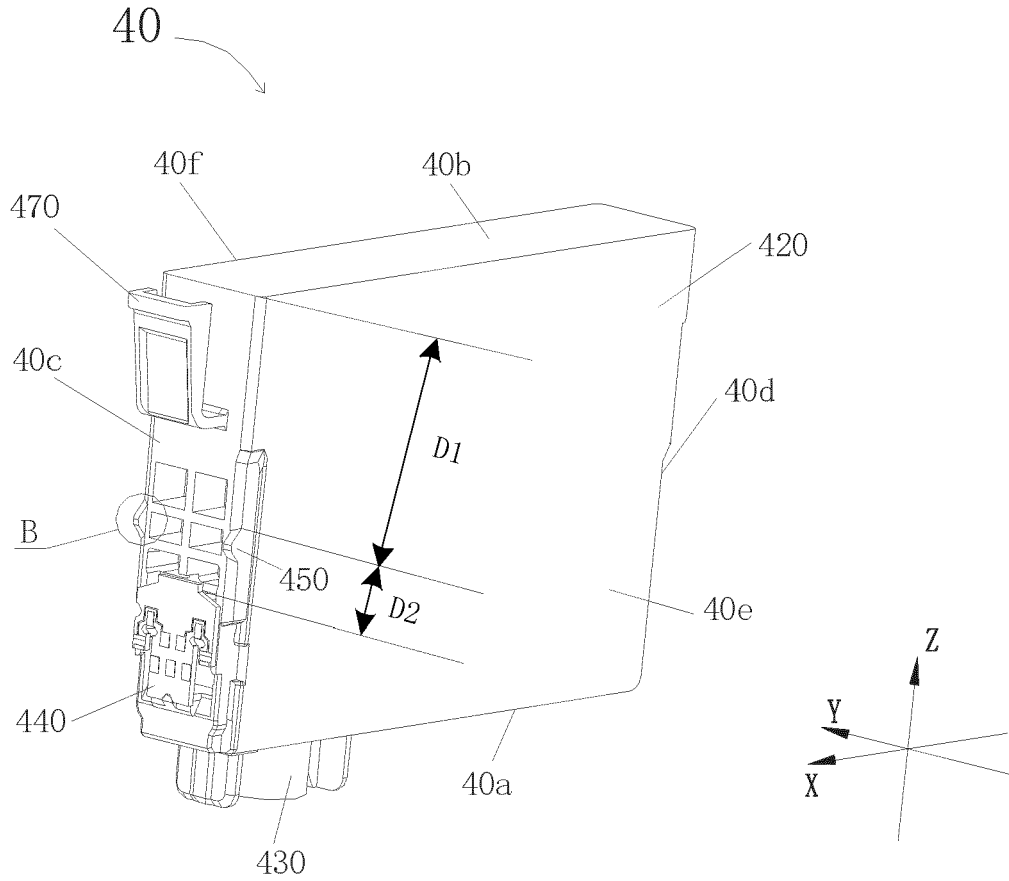

FIG. 13

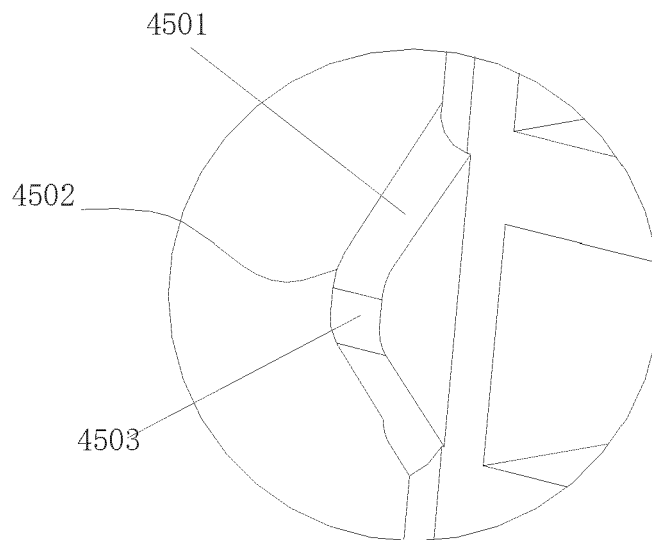

FIG. 14

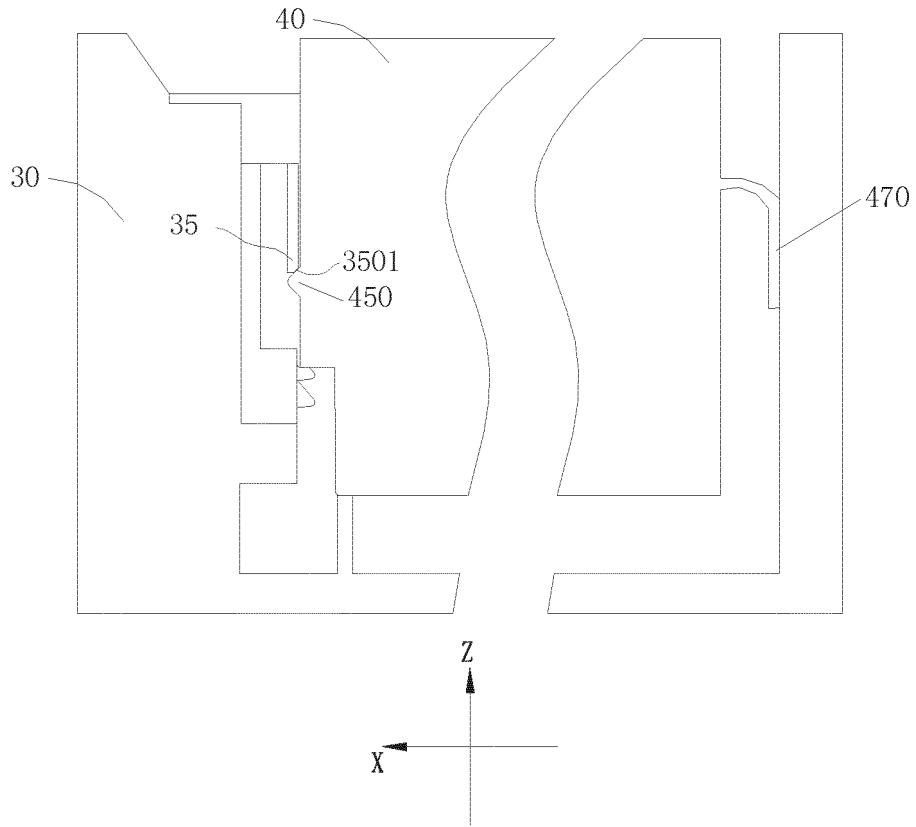

FIG. 15

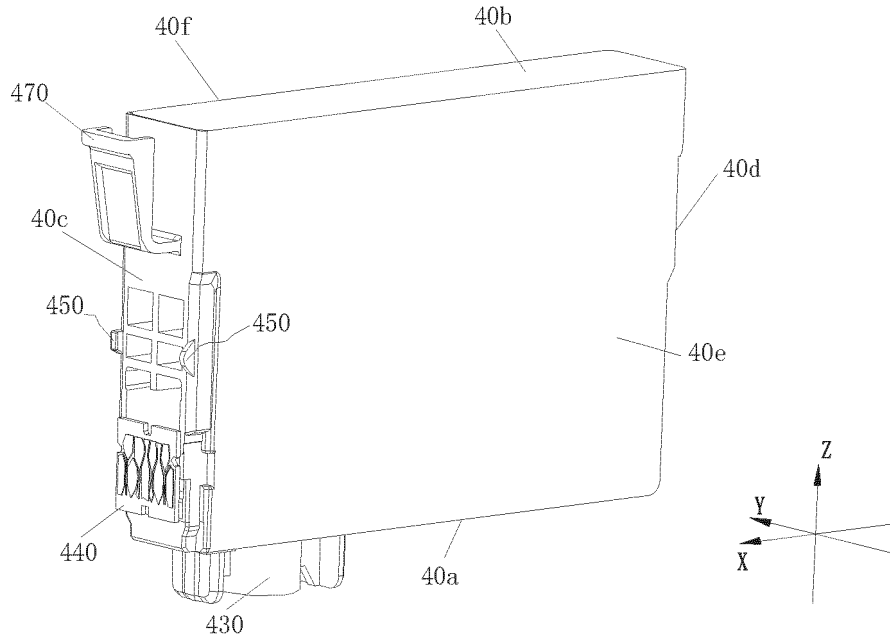

FIG. 16

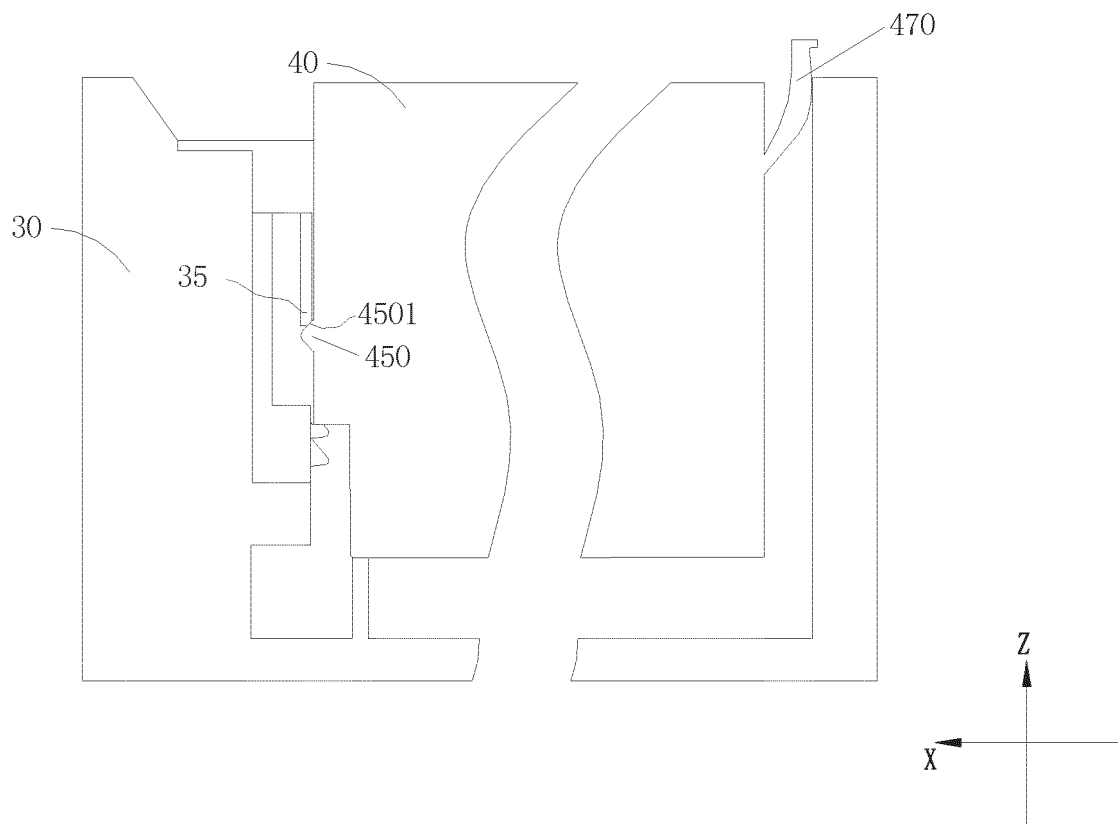

FIG. 17

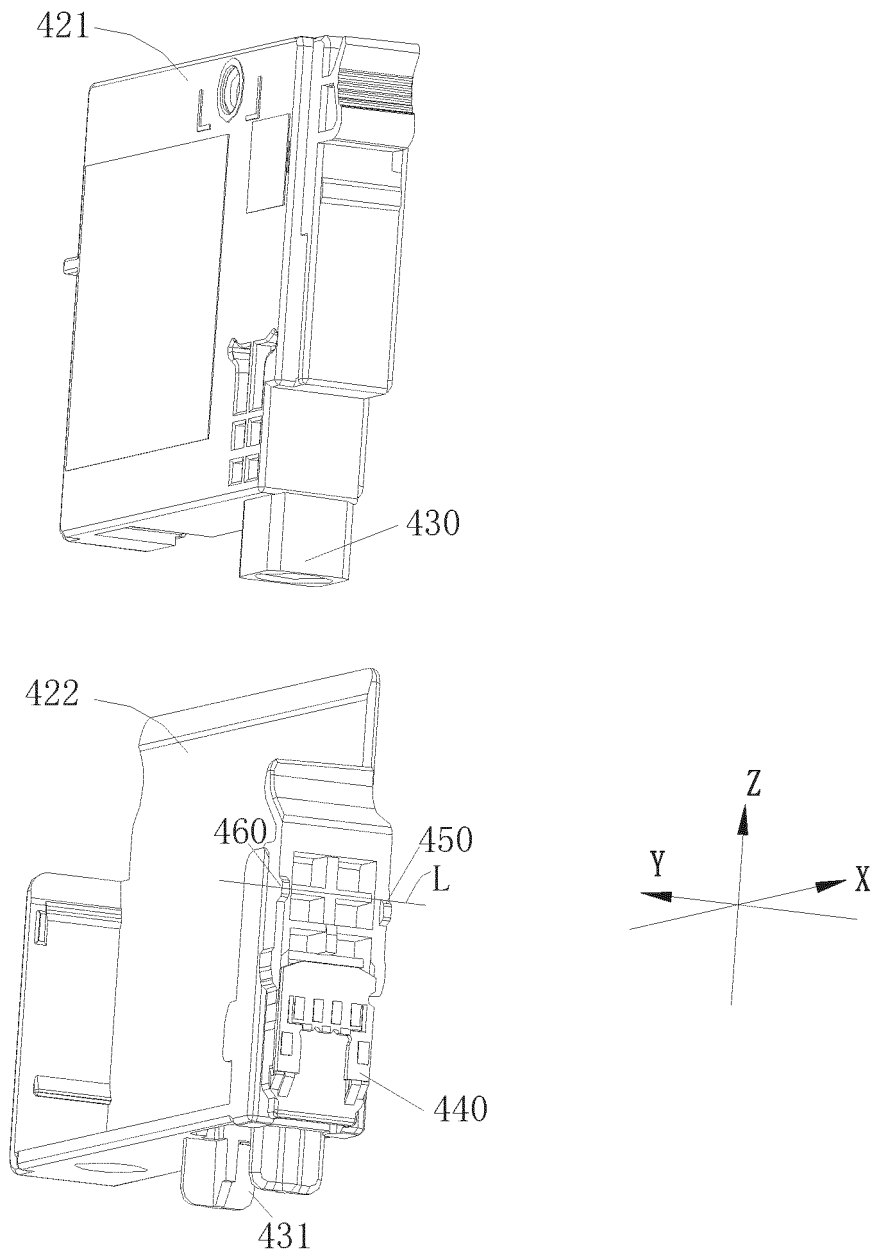

FIG. 18

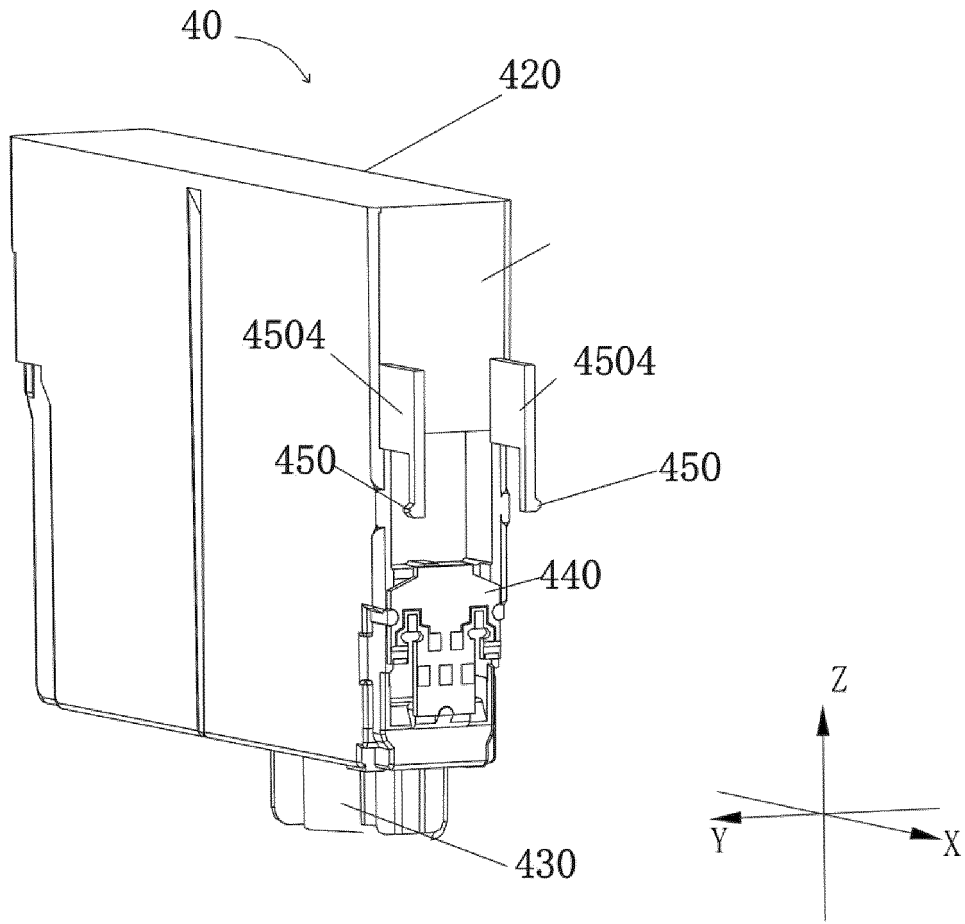

FIG. 19

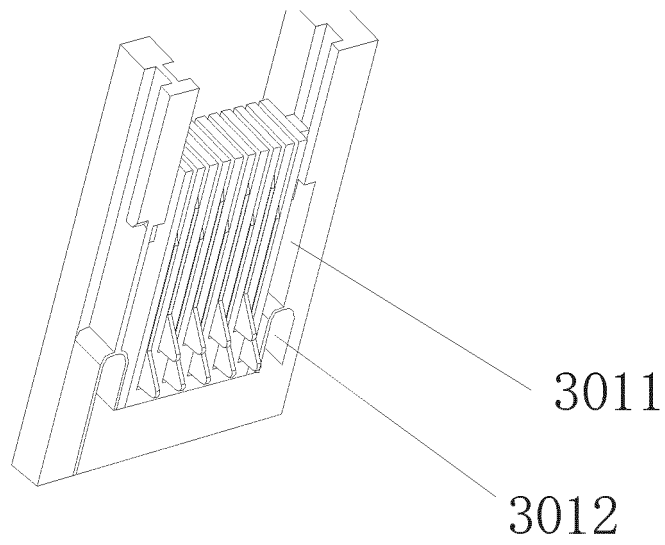

FIG. 20

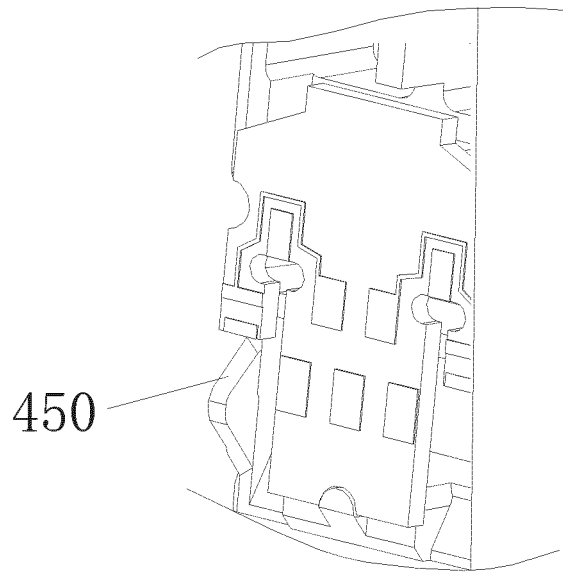

FIG. 21

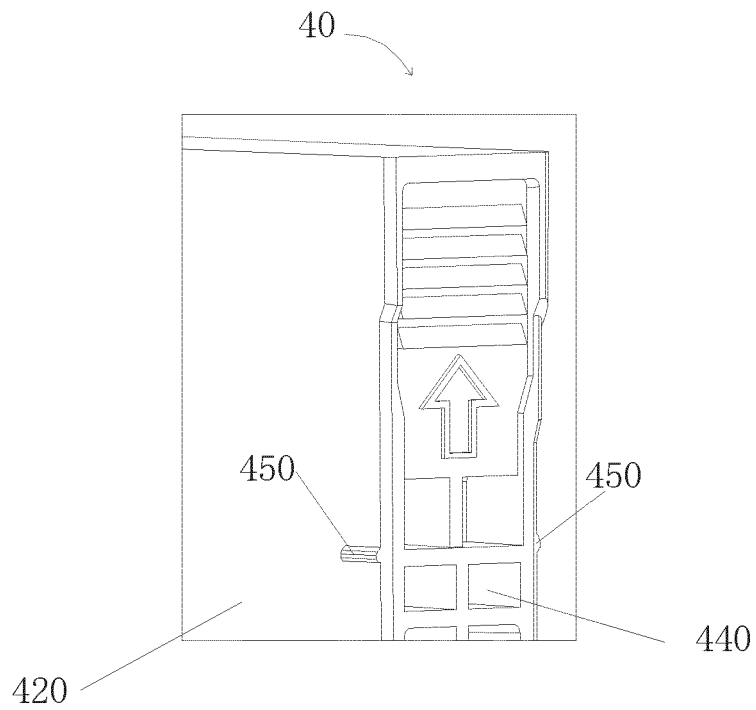

FIG. 22

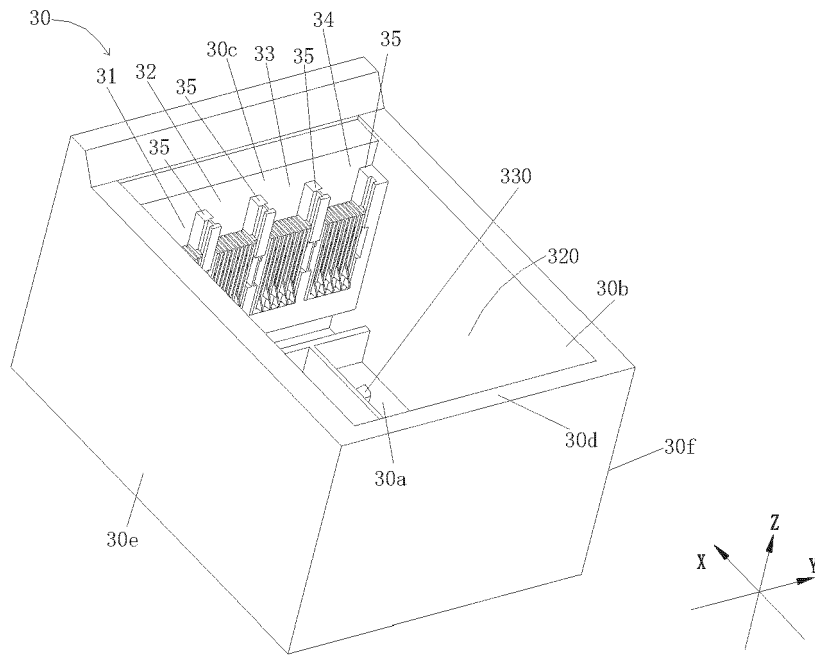

FIG. 23

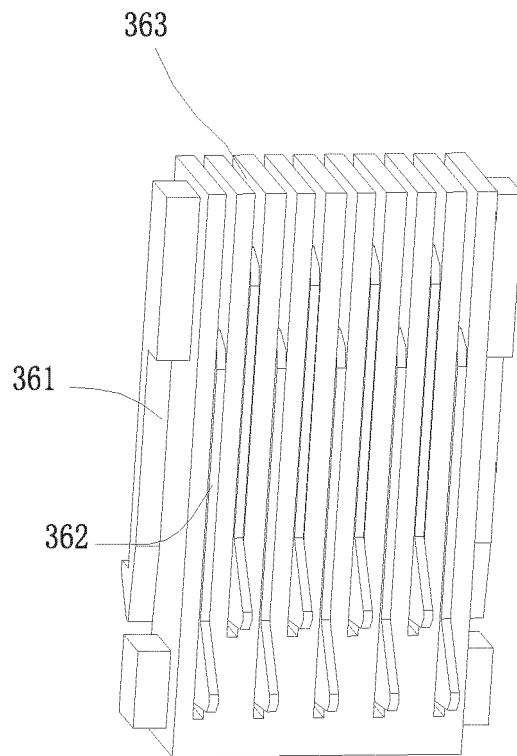

FIG. 24

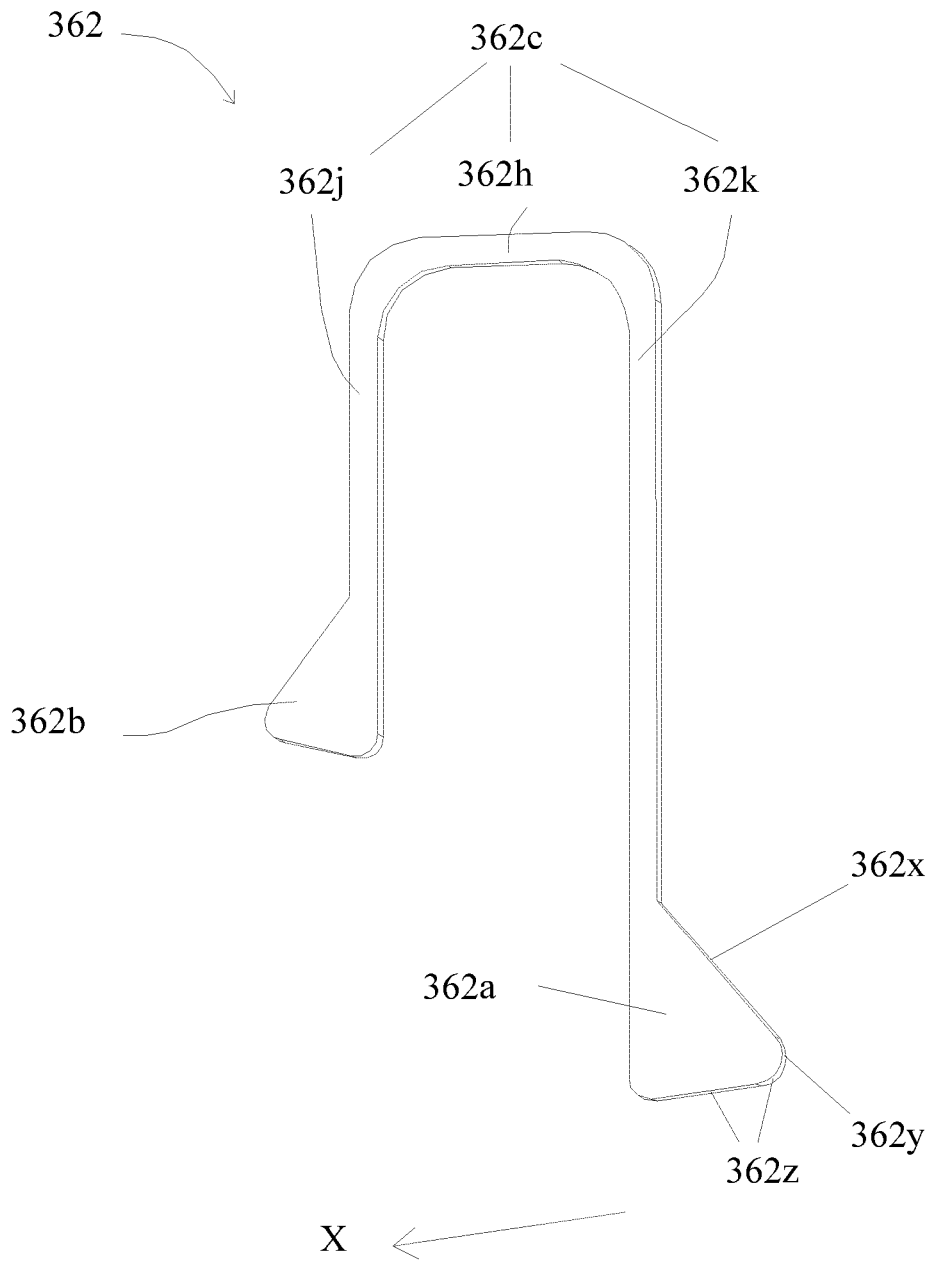

FIG. 25

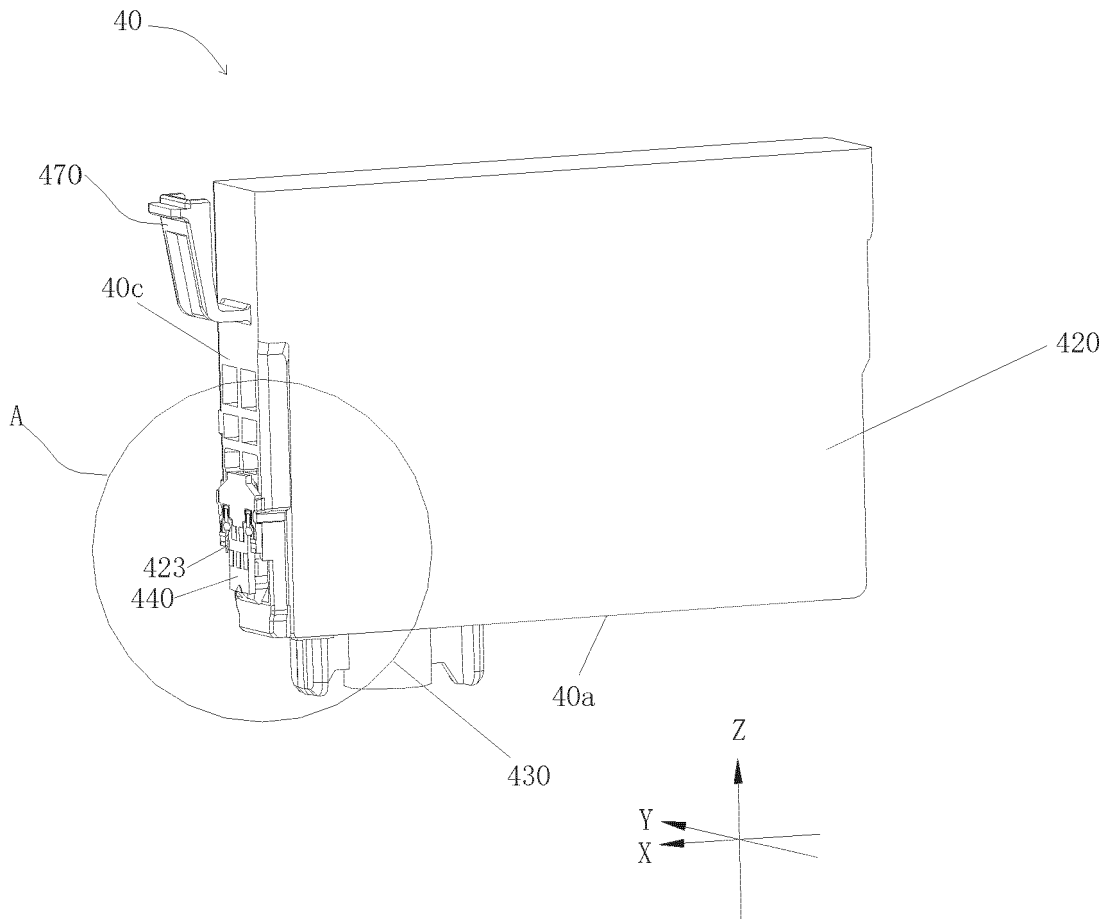

FIG. 26

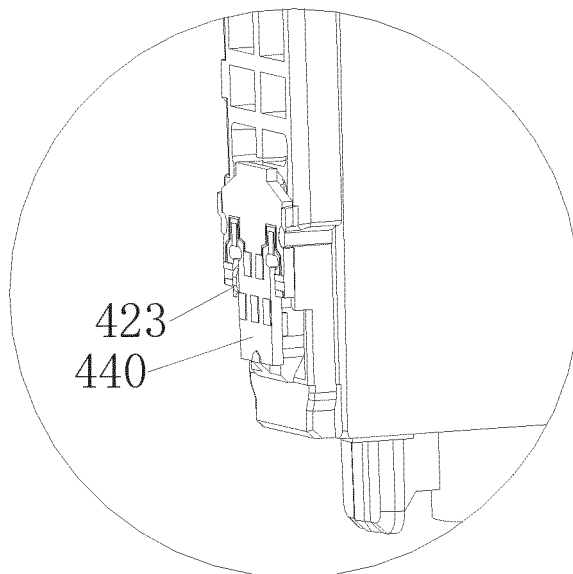

FIG. 27

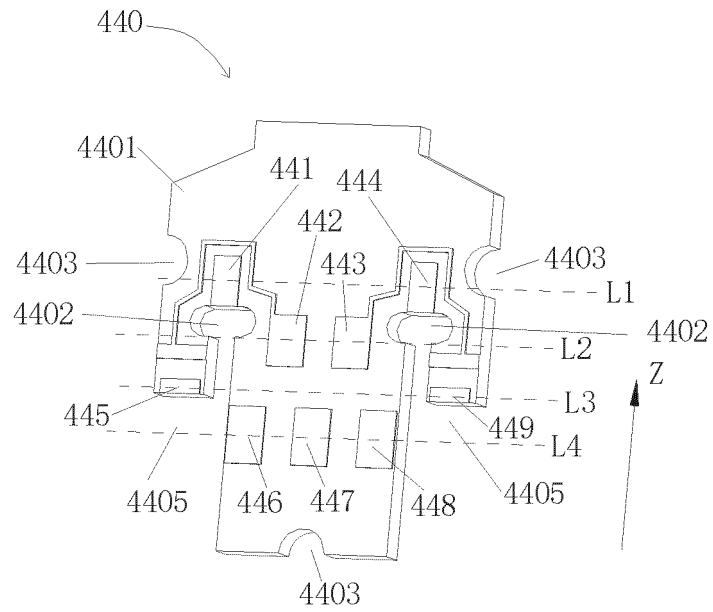

FIG. 28

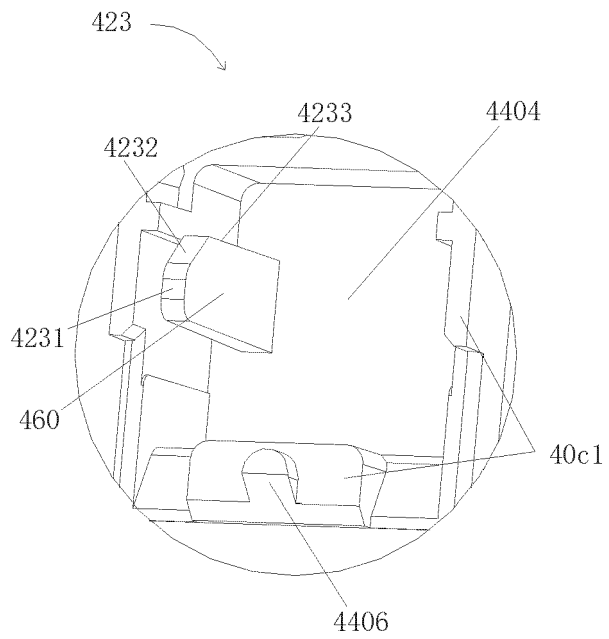

FIG. 29

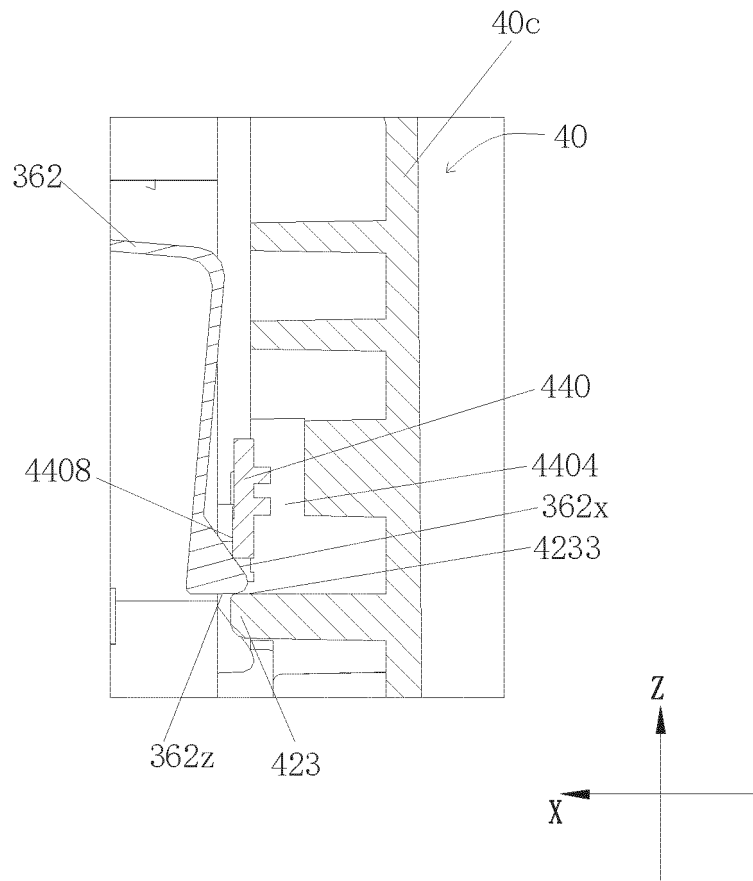

FIG. 30

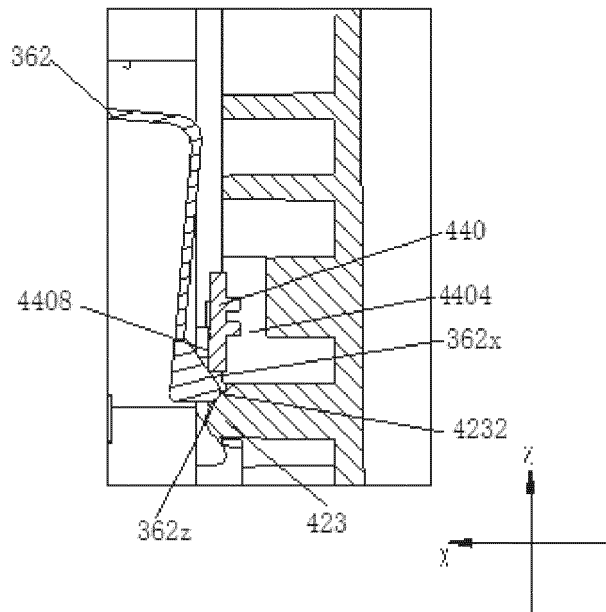

FIG. 31

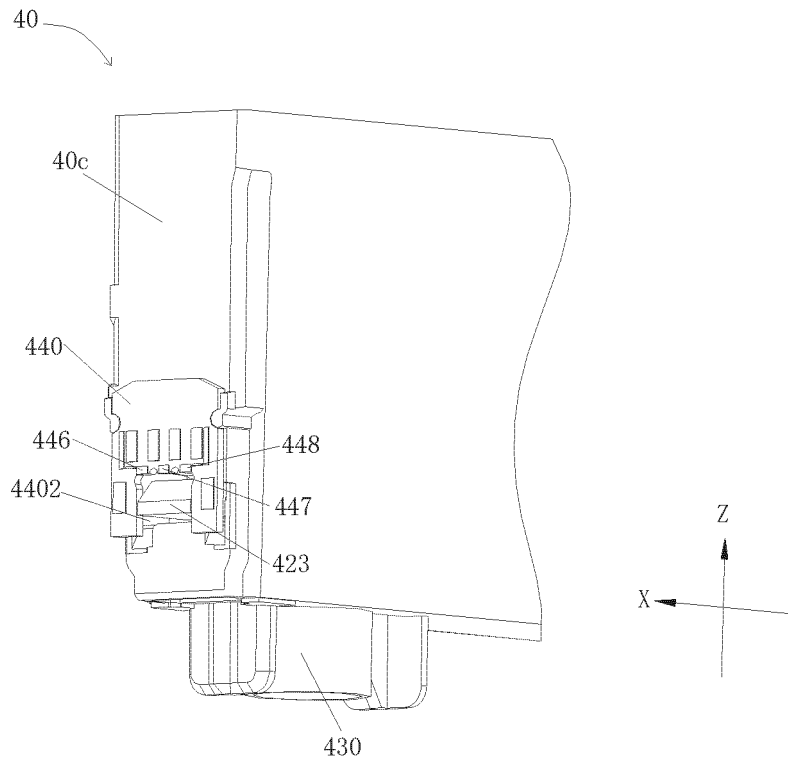

FIG. 32

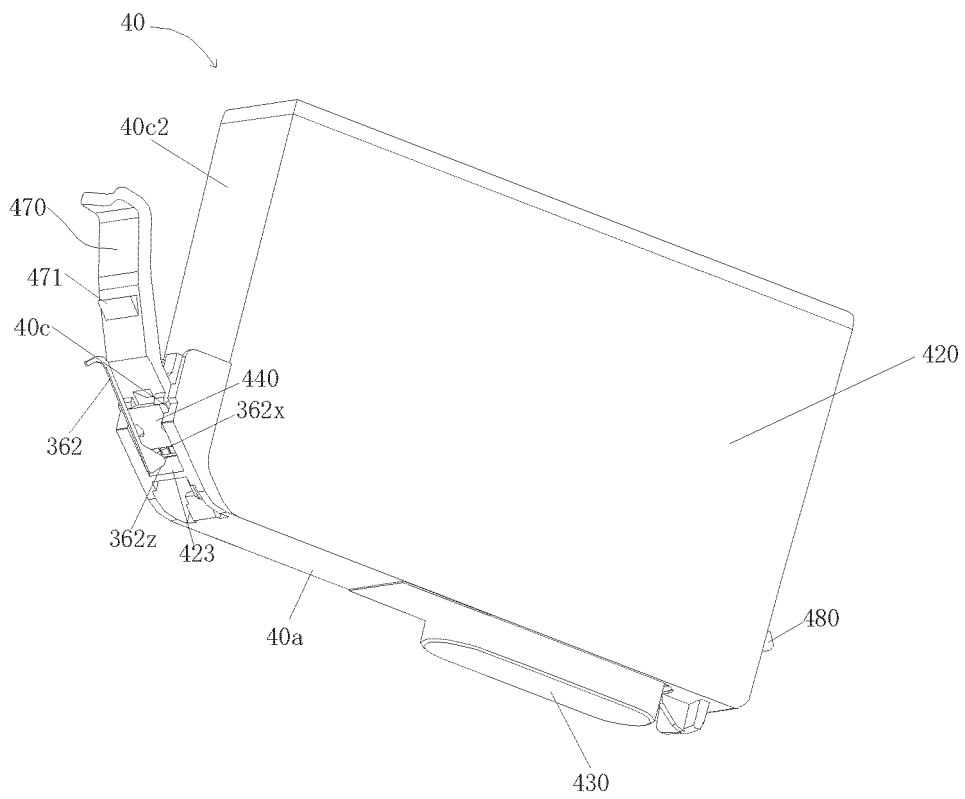

FIG. 33

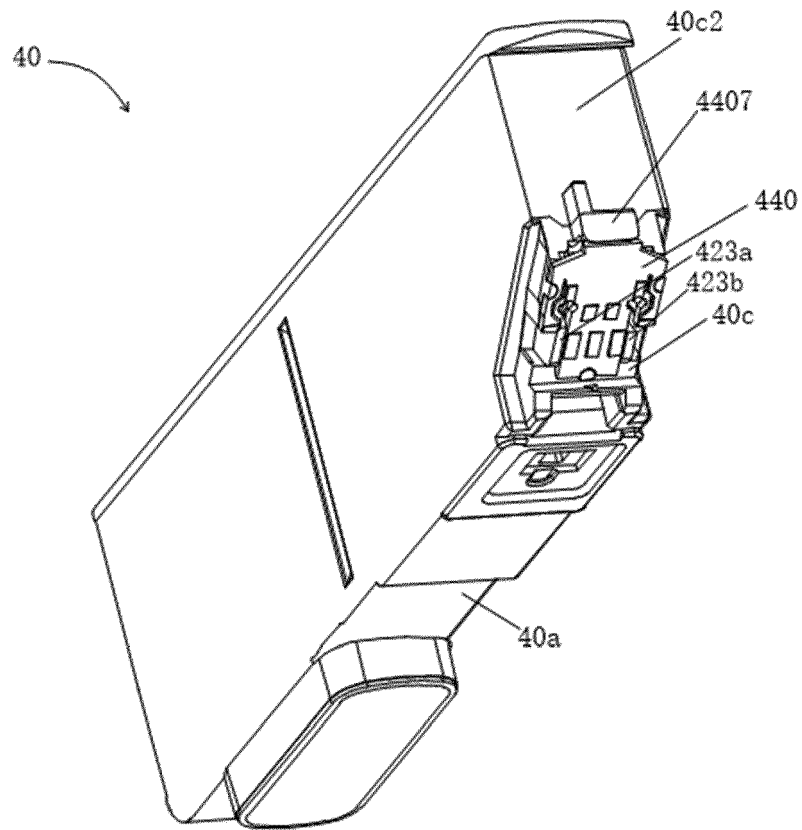

FIG. 34

**REFERENCES CITED IN THE DESCRIPTION**

*This list of references cited by the applicant is for the reader's convenience only. It does not form part of the European patent document. Even though great care has been taken in compiling the references, errors or omissions cannot be excluded and the EPO disclaims all liability in this regard.*

**Patent documents cited in the description**

- US 2020094568 A1 [0005]
- CN 103204005 A [0006]