

(19) World Intellectual Property Organization
International Bureau



(43) International Publication Date
26 June 2003 (26.06.2003)

PCT

(10) International Publication Number
WO 03/051635 A2

(51) International Patent Classification⁷: **B41J**

(21) International Application Number: PCT/US02/39889

(22) International Filing Date:
13 December 2002 (13.12.2002)

(25) Filing Language: English

(26) Publication Language: English

(30) Priority Data:
10/020,217 18 December 2001 (18.12.2001) US

(71) Applicant (for all designated States except US): **SPECTRA, INC.** [US/US]; 101 Etna Road, Lebanon, NH 03766-1422 (US).

(72) Inventors; and

(75) Inventors/Applicants (for US only): **HOISINGTON, Paul, A.** [US/US]; 179 Beaver Meadow Road, Norwich, VT 05055 (US). **ZHOU, Yong** [US/US]; 10 Dunster Drive, Hanover, NH, 03755 (US).

(74) Agent: **FOX, Harold, H.**; Fish & Richardson P.C., 1425 K Street, N.W., 11th Floor, Washington, DC 20005-3500 (US).

(81) Designated States (national): AE, AG, AL, AM, AT, AU, AZ, BA, BB, BG, BR, BY, BZ, CA, CH, CN, CO, CR, CU, CZ, DE, DK, DM, DZ, EC, EE, ES, FI, GB, GD, GE, GH, GM, HR, HU, ID, IL, IN, IS, JP, KE, KG, KP, KR, KZ, LC, LK, LR, LS, LT, LU, LV, MA, MD, MG, MK, MN, MW, MX, MZ, NO, NZ, OM, PH, PL, PT, RO, RU, SC, SD, SE, SG, SK, SL, TJ, TM, TN, TR, TT, TZ, UA, UG, US, UZ, VC, VN, YU, ZA, ZM, ZW.

(84) Designated States (regional): ARIPO patent (GH, GM, KE, LS, MW, MZ, SD, SL, SZ, TZ, UG, ZM, ZW), Eurasian patent (AM, AZ, BY, KG, KZ, MD, RU, TJ, TM), European patent (AT, BE, BG, CH, CY, CZ, DE, DK, EE, ES, FI, FR, GB, GR, IE, IT, LU, MC, NL, PT, SE, SI, SK, TR), OAPI patent (BF, BJ, CF, CG, CI, CM, GA, GN, GQ, GW, ML, MR, NE, SN, TD, TG).

Published:
— without international search report and to be republished upon receipt of that report

For two-letter codes and other abbreviations, refer to the "Guidance Notes on Codes and Abbreviations" appearing at the beginning of each regular issue of the PCT Gazette.

(54) Title: LOW VOLTAGE INK JET PRINTING MODULE

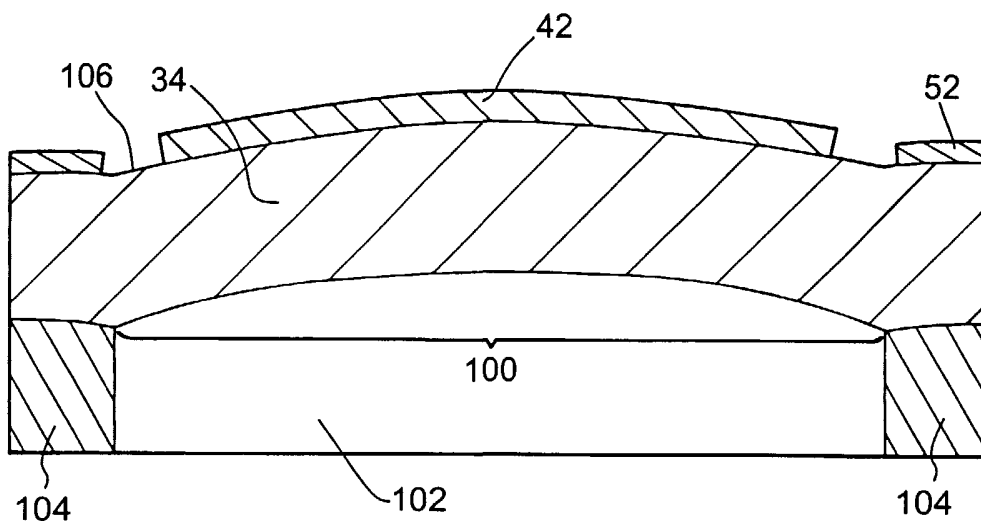

(57) Abstract: A method of manufacturing an ink jet printing module can include forming a piezoelectric element having a stiffened surface.



WO 03/051635 A2

1 **LOW VOLTAGE INK JET PRINTING MODULE**

TECHNICAL FIELD

This invention relates to a method of manufacturing a low voltage ink jet printing module.

5 **BACKGROUND**

An ink jet printing module ejects ink from an orifice in the direction of a substrate. The ink can be ejected as a series of droplets generated by a piezoelectric ink jet printing module. An example of a particular printing module can have 256 jets in four groups of 64 jets each. A piezoelectric ink jet printing module can include a module
10 body, a piezoelectric element, and electrical contacts that drive the piezoelectric element. Typically, the module body is a rectangular member into the surfaces of which are machined a series of ink chambers that serve as pumping chambers for the ink. The piezoelectric element can be disposed over the surface of the body to cover the pumping chambers in a manner to pressurize the ink in the pumping chambers to eject the ink.

15 **SUMMARY**

In general, an ink jet printing module includes a stiffened piezoelectric element. The stiffened piezoelectric element improves jetting of ink when a low voltage is applied to the element compared to non-stiffened piezoelectric element. This can also allow ink jet modules to be smaller because the piezoelectric element
20 has been strengthened. The stiffened piezoelectric element has a rigidity in at least one dimension that is higher than a flat piezoelectric element. The stiffened piezoelectric element can have a curved surface to strengthen the element. The module can jet ink when driven with a voltage of less than 60 volts.

In one aspect, a method of manufacturing an ink jet printing module includes
25 injection molding a precursor into a mold to form a stiffened piezoelectric element, and positioning the piezoelectric element over an ink chamber to subject ink within the chamber to a jetting pressure upon applying a jetting voltage.

In another aspect, a method of depositing ink includes delivering ink to an ink chamber, and applying a jetting voltage across a first electrode and a second electrode

on a face of a stiffened piezoelectric element to subject ink within the chamber to a jetting pressure, thereby depositing ink from an exit orifice of the ink chamber.

In another aspect, an ink jet printing module includes an ink chamber, a stiffened piezoelectric element having a region exposed to the ink chamber, and electrical contacts arranged on a surface of the piezoelectric element for activation of the piezoelectric element when a jetting voltage is applied to the electrical contacts. The piezoelectric element is positioned over the ink chamber to subject ink within the chamber to jetting pressure. The region of the stiffened piezoelectric element exposed to the ink chamber can have a curved surface.

The stiffened piezoelectric element can have a curved surface over the ink chamber. The curved surface can be concave relative to the ink chamber. The curved surface can have a substantially constant radius of curvature. The curved surface can be a spherical section or a cylindrical section. A wall of the chamber can be oriented to contact the stiffened piezoelectric element at an angle of greater than ninety degrees. The piezoelectric element can include lead zirconium titanate.

The ink jet printing module can include a series of chambers. Each of the chambers can be covered by a single piezoelectric element. A first electrode and a second electrode can be placed on a surface of the piezoelectric element.

Details are set forth in the accompanying drawings and the description below. Other features and advantages will be apparent from the description and drawings, and from the claims.

DESCRIPTION OF DRAWINGS

FIGS. 1A and 1B are schematic diagrams depicting an ink jet printing module.

FIG. 2 is a schematic diagram depicting a portion of an ink jet printing module.

FIG. 3 is a schematic diagram depicting a piezoelectric element.

FIG. 4 is a graph depicting pressure generated in an ink chamber as the thickness of the piezoelectric element and curvature is varied.

FIG. 5 is a graph depicting the change in volume generated in an ink chamber as the thickness of the piezoelectric element and curvature is varied.

FIG. 6 is a schematic diagram depicting a piezoelectric element.

FIG. 7 is a graph depicting pressure generated in an ink chamber as the
5 thickness of the piezoelectric element and curvature is varied.

FIG. 8 is a graph depicting the drop volume generated by an ink chamber as the thickness of the piezoelectric element and curvature is varied.

FIG. 9 is a graph depicting the drop volume generated by an ink chamber as the thickness of the piezoelectric element and curvature is varied.

FIG. 10 is a graph depicting pressure generated in an ink chamber as the
10 thickness of the piezoelectric element and curvature is varied.

FIG. 11 is a graph depicting the drop volume generated by an ink chamber as the thickness of the piezoelectric element and curvature is varied.

DETAILED DESCRIPTION

15 An ink jet printing module includes a piezoelectric element positioned over jetting regions of a body. The jetting regions can be portions of pumping chambers within the body. The pumping chambers can be sealed. Electrical contacts, such as electrodes, can be positioned on a surface of the piezoelectric element. The piezoelectric element spans each jetting region. When a voltage is applied to an
20 electrical contact, the shape of the piezoelectric element changes in a jetting region, thereby subjecting the ink within the corresponding pumping chamber to jetting pressure. The ink is ejected from the pumping chamber and deposited on a substrate.

One example of a piezoelectric ink jet printing module is a shear mode module, such as the module described in U.S. Patent No. 5,640,184, the entire
25 contents of which is incorporated herein by reference. The electrical contacts in a shear mode module can be located on the side of the piezoelectric element adjacent to the ink chamber. Referring to **FIGS. 1A, 1B and 2**, piezoelectric ink jet head **2** includes one or more modules **4** which are assembled into collar element **10** to which is attached manifold plate **12** and orifice plate **14**. Ink is introduced into module **4**

through collar 10. Module 4 is actuated to eject ink from orifices 16 on orifice plate 14. Ink jet printing module 4 includes body 20, which can be made from materials such as sintered carbon or a ceramic. A plurality of chambers 22 are machined or otherwise manufactured into body 20 to form pumping chambers.

5 Ink passes through ink fill passage 26, which is also machined into body 20, to fill the pumping chambers. Opposing surfaces of body 4 include a series of electrical contacts 31 and 31' arranged to be positioned over the pumping chambers in body 20. Electrical contacts 31 and 31' are connected to leads, which, in turn, can be connected to integrated circuits 33 and 33'. The components are sealed together to form the
10 print module.

Referring to FIG. 2, piezoelectric element 34 has electrodes 40 on one surface of the piezoelectric element 34. Electrodes 40 register with electrical contacts 31, allowing the electrodes to be individually addressed by a driver integrated circuit. Electrodes 40 can be formed by chemically etching away conductive metal that has
15 been deposited onto the surface of the piezoelectric element. Suitable methods of forming electrodes are also described in U.S. Patent No. 6,037,707, which is herein incorporated by reference in its entirety. The electrode can be formed of conductors such as copper, aluminum, titanium-tungsten, nickel-chrome, or gold. Each electrode 40 is placed and sized to correspond to a chamber 22 in body 4 to form a pumping
20 chamber. Each electrode 40 has elongated region 42, having a length and width slightly narrower than the dimensions of the pumping chamber such that gap 43 exists between the perimeter of electrodes 40 and the sides and end of the pumping chamber. These electrode regions 42, which are centered on the pumping chambers, are the drive electrodes that cover a jetting region of piezoelectric element 34. A
25 second electrode 52 on piezoelectric element 34 generally corresponds to the area of body 20 outside chamber 22, and, accordingly, outside the pumping chamber. Electrode 52 is the common (ground) electrode. Electrode 52 can be comb-shaped (as shown) or can be individually addressable electrode strips. The film electrodes and piezoelectric element electrodes overlap sufficiently for good electrical contact and
30 easy alignment of the film and the piezoelectric element.

The piezoelectric element can be a single monolithic lead zirconium titanate (PZT) member. The piezoelectric element drives the ink from the pumping chambers by displacement induced by an applied voltage. The displacement is a function of, in part, the poling of the material. The piezoelectric element is poled by the application of an electric field. A poling process is described, for example, in U.S. Patent No. 5,605,659, which is herein incorporated by reference in its entirety. The degree of poling can depend on the strength and duration of the applied electric field. When the poling voltage is removed, the piezoelectric domains are aligned. The piezoelectric element can have a thickness of 5 to 300 microns, 10 to 250 microns, 15 to 150 microns, less than 100 microns, or less than 50 microns.

Subsequent applications of an electric field, for example, during jetting, can cause a shape change proportional to the applied electric field strength.

The piezoelectric element can be stiffened, for example, by introducing a curved surface in a portion of the element that covers the ink chamber. The curved surface can have a substantially constant curvature, such as a spherical or cylindrical shape. Referring to FIG. 3, a region **100** of piezoelectric element **34** is curved. The curvature of the piezoelectric element **34** is concave relative to ink chamber **102**. The concave curvature of the surface can reduce buckling that otherwise may occur during jetting. Walls **104** of the chamber **102** can be oriented to contact the stiffened piezoelectric element **34** at an angle of greater than ninety degrees. The chamber can have a width of less than 1200 microns, a width of 50 to 1000 microns, or a width of 100 to 800 microns. Electrodes **42** and **52** are on surface **106** of the piezoelectric element **34**. By applying a jetting voltage across the electrodes, ink within the chamber is subjected to a jetting pressure, which deposits ink from an exit orifice of the ink chamber. For example, the jetting voltage can be less than 60 volts.

The curved surface can have a substantially constant radius of curvature. The degree of curvature, or radius of curvature, affects the stiffness and jetting characteristics of the module. The radius of curvature is the radius of a circle drawn to encompass the curved surface. The curved surface can have a radius of curvature of less than 5 millimeters, or less than 3 millimeters. The curved surface can have a

radius of curvature of 500 to 3000 microns, 1000 to 2800 microns, or 1500 to 2600 microns. The curved surface can be a cylindrical section or a spherical section.

The ink jet printing module can be prepared by forming a stiffened piezoelectric element, and positioning the piezoelectric element over an ink chamber to subject ink within the chamber to a jetting pressure upon applying a jetting voltage. The stiffened piezoelectric element can be prepared by grinding a curved surface into a thin layer of piezoelectric material or by injection molding a precursor into a mold having the curved surface features of the piezoelectric element. For example, a mixture can be prepared from a piezoelectric material powder and an organic binder. The mixture is injection molded to form a green sheet, which can be heated to remove the binder. The green sheet can be a thin film having a thickness of 10 to 50 microns, or 20 to 40 microns. The powder can be sintered, for example, to at least about 95% of theoretical density. Injection molding to form a piezoelectric article is described, for example, in U.S. Patent No. 5,340,510, which is incorporated by reference in its entirety.

The curvature stiffens the piezoelectric element and improves jetting of ink when a low voltage is applied to the element. A comparable ink jet printing module having a flat piezoelectric element requires application of a higher voltage to jet an ink drop of comparable volume. A concave surface relative to the chamber can lead to higher positive pressure within the chamber than negative pressure during jetting, for example, a pressure during jetting that can be up to two times higher the pressure during chamber filling. Reducing the dimensions of the ink jet printing module can also lead to higher voltage requirements to achieve a given drop volume. Smaller jets can make the print head more compact. The stiffened element can also allow ink jet modules to be made smaller because the piezoelectric element has a rigidity in at least one dimension that is higher than a flat piezoelectric element. When the piezoelectric element is curved in the resting state, the deflection normal to the piezoelectric element can be amplified relative to a flat plate. Moreover, thinner ink chambers can allow smaller-dimensioned jets having improved performance to be made.

Finite element analysis modeling of structures having a cylindrical shape (as shown in Fig. 3), a particular radius of curvature, and operated in an extension mode, demonstrated the improved pumping performance of the stiffened piezoelectric element relative to a flat element. In the model, ANSYS multiphysics coupled field analysis (ANSYS Version 5.7, ANSYS Inc. of Canonsburg, PA) was employed using the parameters of an ink chamber diameter of 0.102 cm, an ink chamber depth of 0.152 mm, lead zirconium titanate (PZT 5A, Morgan Electro Ceramics, Bedford, Ohio) poled in the thickness direction, a cavity plate constructed of KOVAR® (a low expansion iron-nickel-cobalt alloy available from High Temp Metals, Inc., Sylmar, CA), land piezoelectric width (the distance between chambers) of 0.254 mm, an ink density of 1000 kg/m³, a pulse voltage of 50 volts, element thickness ranging from 1 mil (25.4 microns) to 10 mils (254 microns) and a radius of curvature of 30 mils, 40 mils, 50 mils, 100 mils or infinity (flat). The pressures and displacements generated by stiffened piezoelectric elements having particular thicknesses and radii of curvature are listed in Table 1. Pressures and total volume generated by stiffened piezoelectric elements are depicted in Figs. 4 and 5. A comparative example of a flat piezoelectric element at a jetting voltage of 100 volts in shear mode is included as a comparison.

Table 1

Example	PZT Thickness (mils)	Radius of curvature (mils)	Maximum Displacement ($\mu\text{m}/\mu\text{in}$)	Pressure (Pa/PSI)
1	8 (203 microns)	100 (2.54 mm)	0.0229/0.901	-73424/-10.6
2	5 (127 microns)	100 (2.54 mm)	0.0655/2.61	-122827/-17.8
3	8	50 (1.27 mm)	0.0347/1.36	-96501/-13.9
4	5	50 (1.27 mm)	0.0852/3.35	-172939/-25.1

20

Finite element analysis modeling of structures depicted in Fig. 6 having a spherical shape, a particular radius of curvature, operated in extension mode, and a constant total chamber volume also demonstrated the improved pumping performance of the stiffened piezoelectric element relative to a flat element. In this model, ANSYS

multiphysics coupled field analysis was employed using the parameters of an ink chamber diameter of 0.102 cm, lead zirconium titanate (PZT 5A) poled in thickness direction, a cavity plate constructed of KOVAR®, land piezoelectric width (the distance between chambers) of 0.254 mm, an ink density of 1000 kg/m^3 , a pulse voltage of 50 volts, piezoelectric element thickness ranging from 1 mil (25.4 microns) to 10 mils (254 microns) and a radius of curvature of 20 mils, 30 mils, 40 mils, 50 mils or infinity (flat). The volume of pumping chamber was kept at $3.14 \times 10^{-10} \text{ m}^3$, which is same as the total volume in the comparative case. Since the chamber diameter is also a constant (0.102 cm) and the radius of curvature varies, the chamber depth becomes a variable. The chamber depth for each radius of curvature was: R = 20 mil, depth = 2 mil; R = 30 mil, depth = 11.33 mil; R = 40 mil, depth = 12.59 mil; or R = 50 mil, depth = 13.22 mil. The pressures and drop volumes generated by stiffened piezoelectric elements having particular thicknesses and radii of curvature are listed in Table 2. Chamber pressures and drop volumes generated by stiffened piezoelectric elements are depicted in Figs. 7 and 8. A comparative example of a flat piezoelectric element at a jetting voltage of 100 volts in shear mode is included as a comparison.

Table 2

Example	PZT Thickness (mils)	Radius of curvature (mils)	Drop Volume (pL)	Chamber Pressure (PSI)
5	1	50	131.228	87.214
6	1	40	133.948	89.039
7	1	30	129.770	86.219
8	1	20	108.323	71.975
9	2	50	79.418	52.793
10	2	40	79.210	52.621
11	2	30	74.931	49.938
12	2	20	65.243	43.350
13	3	50	52.607	35.003
14	3	40	53.339	35.462
15	3	30	52.048	34.591
16	3	20	47.289	31.421
17	4	50	37.363	24.844
18	4	40	38.614	25.704
19	4	30	38.713	25.760
20	4	20	37.351	24.817
21	5	50	27.841	18.509
22	5	40	29.173	19.464
23	5	30	30.405	20.245
24	5	20	30.862	20.534
25	6	50	21.410	14.270
26	6	40	22.986	15.312
27	6	30	24.595	16.370
28	6	20	26.384	17.548
29	7	50	17.299	11.529
30	7	40	18.723	12.486
31	7	30	20.271	13.555
32	7	20	23.093	15.371
33	8	50	14.300	9.555
34	8	40	15.564	10.393
35	8	30	16.819	11.274
36	8	20	20.519	13.680
Comparative 37 ^a	10	Flat	46.221	29.008

^a 100V driving voltage

Additional finite element analysis modeling of structures depicted in Fig. 6 having a spherical shape, a particular radius of curvature, operated in extension mode, and a constant total volume demonstrated the improved pumping performance of the stiffened piezoelectric element relative to a flat element. In this model, ANSYS multiphysics coupled field analysis was employed using the parameters of an ink chamber diameter of 0.102 cm, an ink chamber depth of 0.152 mm, lead zirconium titanate (PZT 5A) poled in thickness direction, a cavity plate constructed of KOVAR®, and piezoelectric width (the distance between chambers) of 0.254 mm, an

ink density of 1000 kg/m^3 , a pulse voltage of 50 volts, piezoelectric element thickness ranging from 1 mil (25.4 microns) to 8 mils (203 microns) and a radius of curvature of 20 mils, 30 mils, 40 mils, or 50 mils. Since the chamber diameter is also a constant (0.102 cm) and the radius of curvature varies, the chamber depth becomes a variable.

5 The chamber depth for each radius of curvature was: $R = 20 \text{ mil}$, depth = 2 mil; $R = 30 \text{ mil}$, depth = 11.33 mil; $R = 40 \text{ mil}$, depth = 12.59 mil; or $R = 50 \text{ mil}$, depth = 13.22 mil. The drop volumes generated by stiffened piezoelectric elements having particular thicknesses and radii of curvature are depicted in Fig. 9.

Other finite element analysis modeling of structures depicted in Fig. 6 having
10 a spherical shape, a particular radius of curvature, operated in extension mode, and a constant total chamber volume also demonstrated the improved pumping performance of the stiffened piezoelectric element relative to a flat element. In this model, ANSYS multiphysics coupled field analysis was employed using the parameters of an ink chamber diameter of 0.102 cm, an ink chamber depth of 0.152 mm, lead zirconium
15 titanate (PZT 5A) poled in thickness direction, a cavity plate constructed of KOVAR®, land piezoelectric width (the distance between chambers) of 0.254 mm, an ink density of 1000 kg/m^3 , a pulse voltage of 15 volts, piezoelectric element thickness of 0.04 mil (1 micron), 0.10 mil (2.5 microns), 0.30 mil (7.5 microns), 0.50 mil (12.5
20 microns) or 10 mils (254 microns) and a radius of curvature of 30 mils, 40 mils, 50 mils or infinity (flat). Since the chamber diameter is also a constant (0.102 cm) and the radius of curvature varies, the chamber depth becomes a variable. The chamber depth for each radius of curvature was: $R = 30 \text{ mil}$, depth = 11.33 mil; $R = 40 \text{ mil}$,
depth = 12.59 mil; or $R = 50 \text{ mil}$, depth = 13.22 mil. The pressures and drop volumes generated by stiffened piezoelectric elements having particular thicknesses and radii
25 of curvature are listed in Table 3. Chamber pressures and drop volumes generated by stiffened piezoelectric elements are depicted in Figs. 10 and 11. A comparative example of a flat piezoelectric element at a jetting voltage of 100 volts in shear mode is included as a comparison.

Table 3

Example	PZT Thickness (mils)	Radius of curvature (mils)	Drop Volume (pL)	Chamber Pressure (PSI)
38	0.04	30	77.121	116.199
39	0.04	40	62.607	94.260
40	0.04	50	51.683	77.890
41	0.10	30	69.069	104.067
42	0.10	40	58.078	87.422
43	0.10	50	48.929	73.738
44	0.30	30	50.714	76.390
45	0.30	40	46.576	70.108
46	0.30	50	41.443	62.445
47	0.50	30	39.929	60.113
48	0.50	40	38.690	58.226
49	0.50	50	35.797	53.901
Comparative 50 ^a			29.008	46.221

^a 100V driving voltage

A number of embodiments have been described. Other embodiments are within the scope of the following claims.

WHAT IS CLAIMED IS:

1. A method of manufacturing an ink jet printing module comprising:
injection molding a precursor into a mold to form a stiffened piezoelectric element; and
5 positioning the piezoelectric element over an ink chamber to subject ink within the chamber to a jetting pressure upon applying a jetting voltage.
2. The method of claim 1, wherein the stiffened piezoelectric element has a curved surface over the ink chamber.
3. The method of claim 2, wherein the curved surface is concave relative to
10 the ink chamber.
4. The method of claim 2, wherein the curved surface has a substantially constant radius of curvature.
5. The method of claim 1, wherein the piezoelectric element includes lead zirconium titanate.
- 15 6. The method of claim 1, wherein the jetting voltage is less than 60 volts.
7. The method of claim 2, wherein the curved surface has a radius of curvature of less than 5 millimeters.
8. The method of claim 2, wherein the curved surface has a radius of curvature of less than 3 millimeters.
- 20 9. The method of claim 1, further comprising placing a first electrode and a second electrode on a surface of the piezoelectric element.
10. The method of claim 1, wherein the piezoelectric element has a thickness of less than 50 microns.
11. The method of claim 1, further comprising orienting a wall of the chamber
25 to contact the stiffened piezoelectric element at an angle of greater than ninety degrees.
12. A method of depositing ink comprising:
delivering ink to an ink chamber; and

applying a jetting voltage across a first electrode and a second electrode on a face of a stiffened piezoelectric element to subject ink within the chamber to a jetting pressure, thereby depositing ink from an exit orifice of the ink chamber.

5 13. The method of claim 12, wherein the stiffened piezoelectric element has a curved surface over the ink chamber.

 14. The method of claim 13, wherein the curved surface is concave relative to the ink chamber.

 15. The method of claim 13, wherein the curved surface has a substantially
10 constant radius of curvature.

 16. The method of claim 13, wherein the piezoelectric element includes lead zirconium titanate.

 17. The method of claim 13, wherein the jetting voltage is less than 60 volts.

 18. The method of claim 14, wherein the curved surface has a radius of
15 curvature of less than 5 millimeters.

 19. An ink jet printing module comprising:

 an ink chamber;

 a stiffened piezoelectric element having a region exposed to the ink chamber,
the piezoelectric element being positioned over the ink chamber to subject ink within
20 the chamber to jetting pressure; and

 electrical contacts arranged on a surface of the piezoelectric element for
activation of the piezoelectric element.

 20. The ink jet printing module of claim 19, wherein the region of the
stiffened piezoelectric element exposed to the ink chamber has a curved surface.

 21. The ink jet printing module of claim 20, wherein the curved surface is
25 concave relative to the ink chamber.

 22. The ink jet printing module of claim 20, wherein the curved surface has a
substantially constant radius of curvature.

23. The ink jet printing module of claim 19, wherein the piezoelectric element includes lead zirconium titanate.

24. The ink jet printing module of claim 19, wherein the piezoelectric element has a thickness of 5 to 300 microns.

5 25. The ink jet printing module of claim 19, wherein the piezoelectric element has a thickness of 10 to 250 microns.

26. The ink jet printing module of claim 19, wherein the piezoelectric element has a thickness of less than 100 microns.

10 27. The ink jet printing module of claim 19, wherein the chamber has a width of less than 1200 microns.

28. The ink jet printing module of claim 19, wherein the chamber has a width of 50 to 1000 microns.

29. The ink jet printing module of claim 19, wherein the chamber has a width of 100 to 800 microns.

15 30. The ink jet printing module of claim 20, wherein the curved surface has a radius of curvature of 500 to 3000 microns.

31. The ink jet printing module of claim 20, wherein the curved surface has a radius of curvature of 1000 to 2800 microns.

20 32. The ink jet printing module of claim 20, wherein the curved surface has a radius of curvature of 1500 to 2600 microns.

33. The ink jet printing module of claim 19, wherein the electrodes are configured to apply a voltage of less than 60 volts.

34. The ink jet printing module of claim 19, further comprising a series of chambers.

25 35. The ink jet printing module of claim 34, wherein each of the chambers is covered by a single piezoelectric element.

36. The ink jet printing module of claim 19, wherein the chamber includes a wall contacting the piezoelectric element exposed to the ink chamber at an angle of greater than ninety degrees.

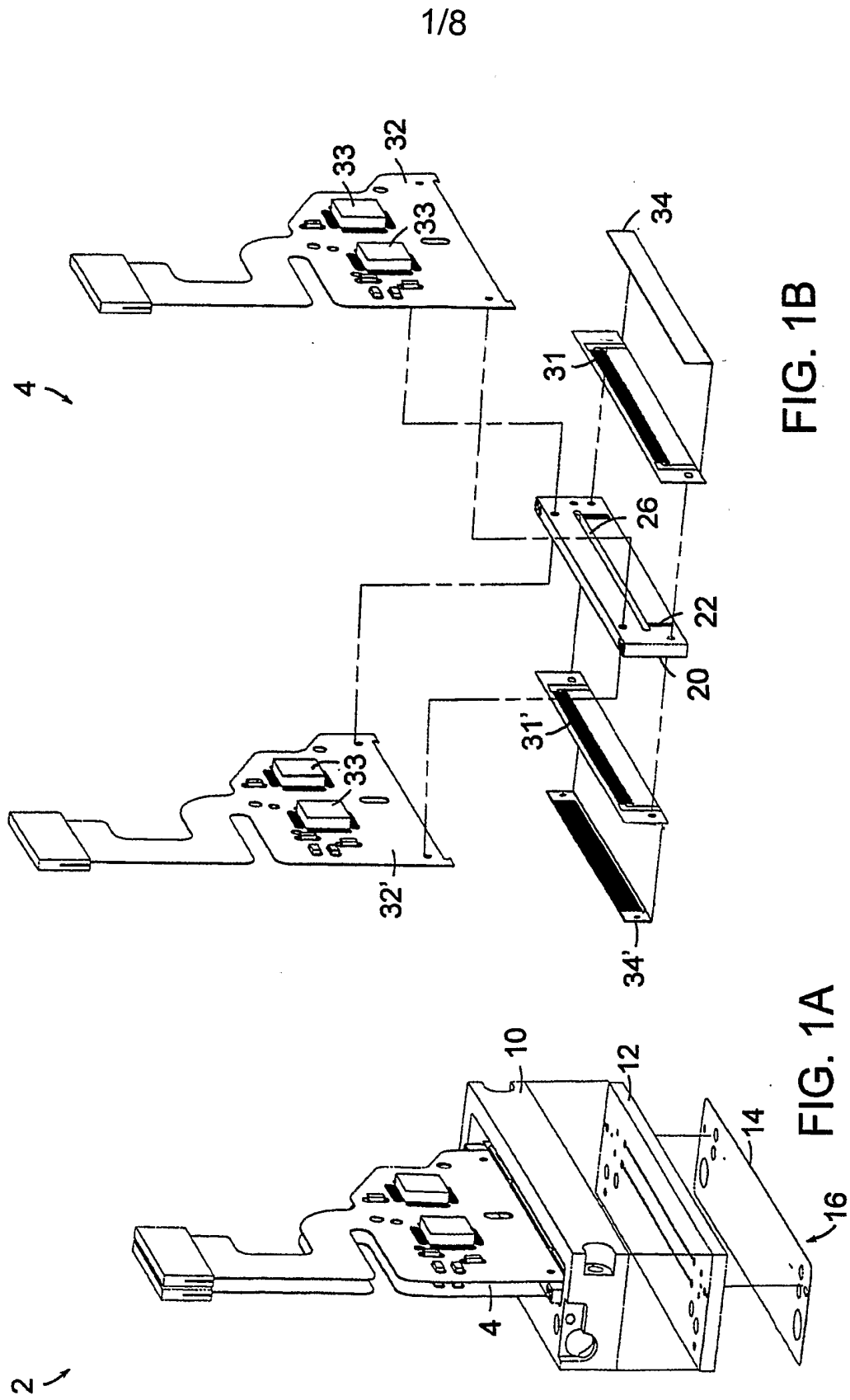

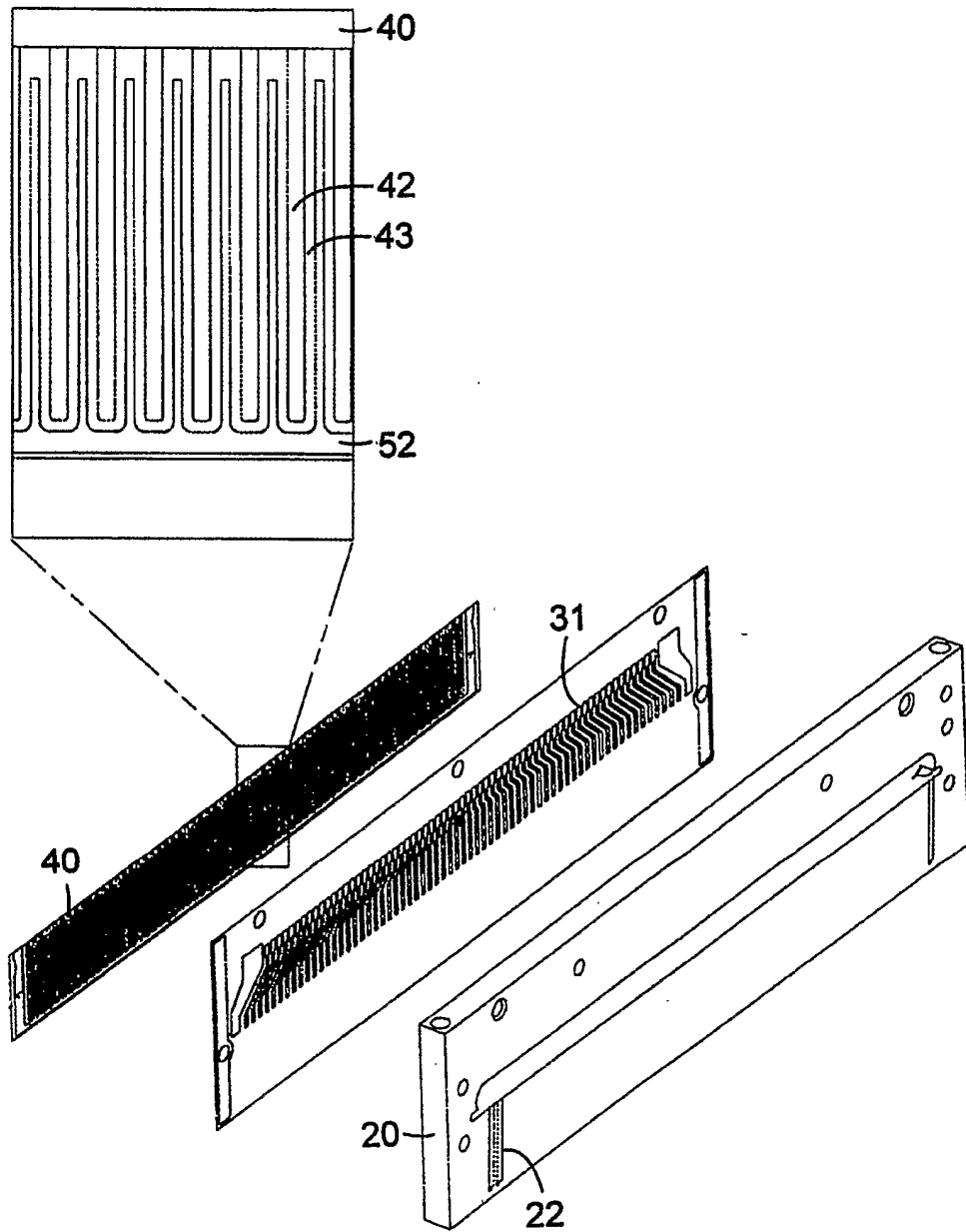

FIG. 2

3/8

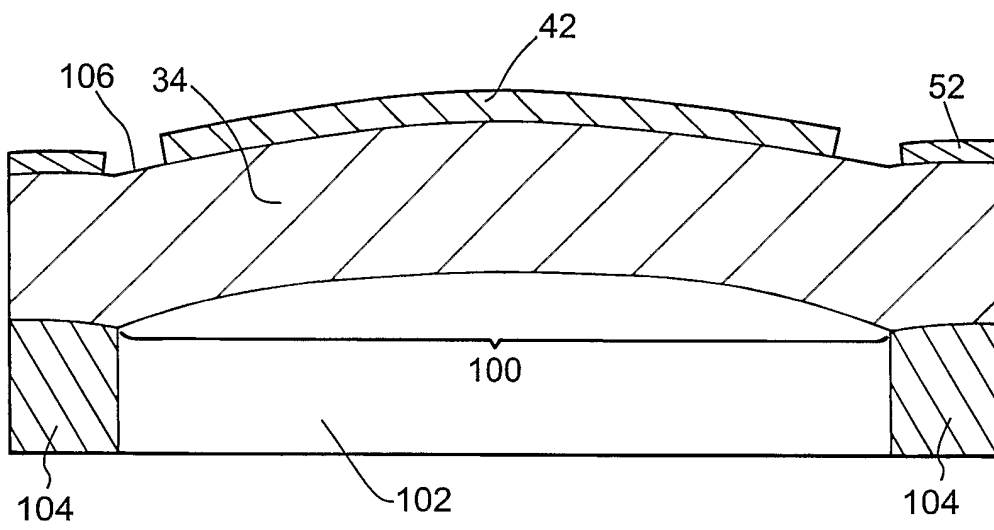

FIG. 3

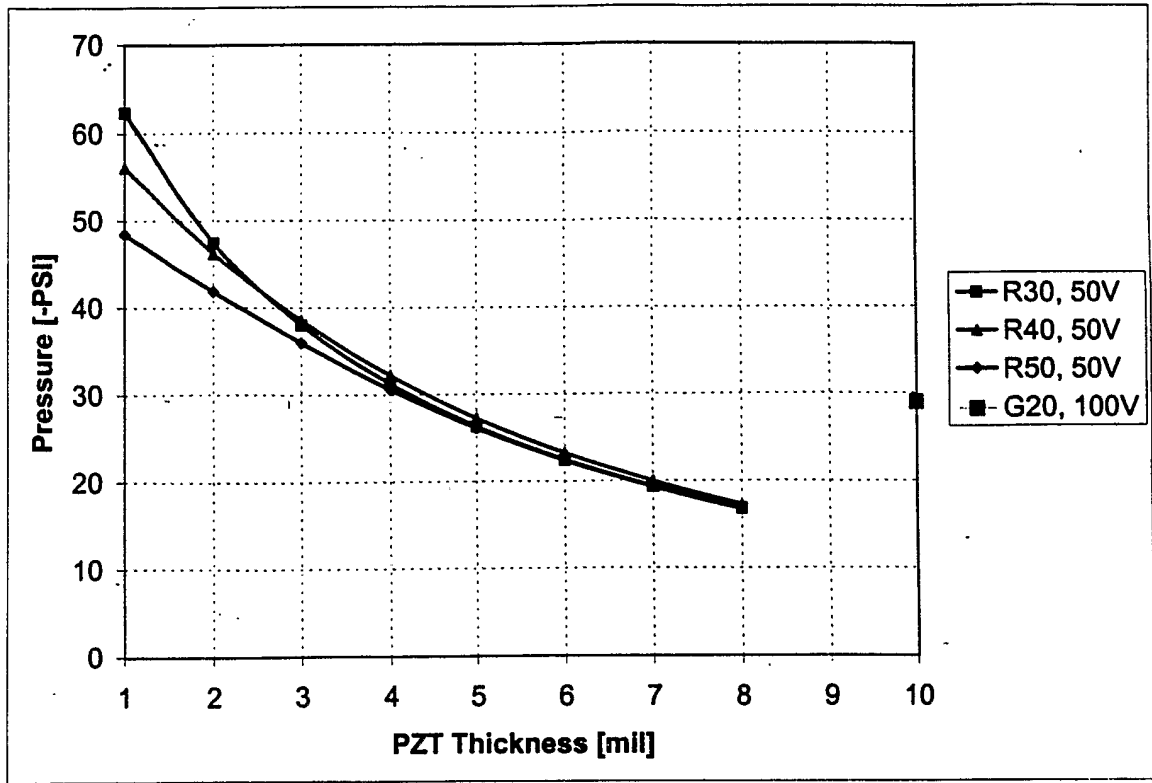

FIGURE 4

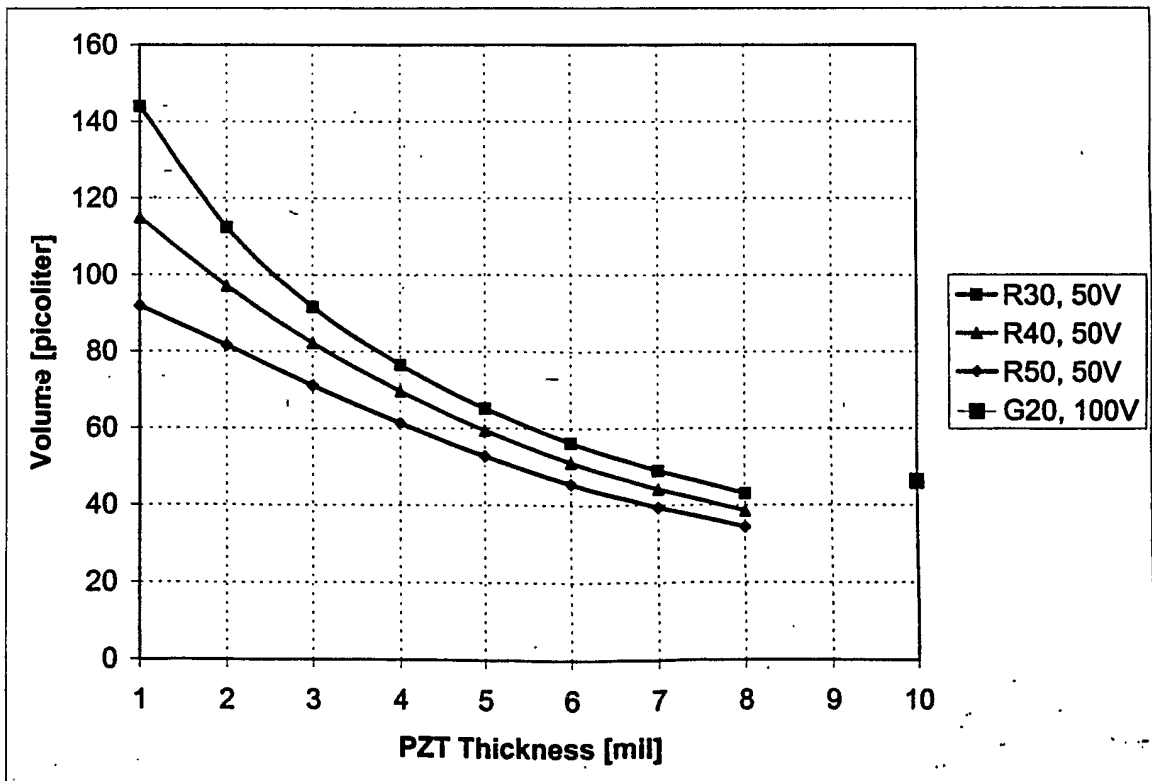

FIGURE 5

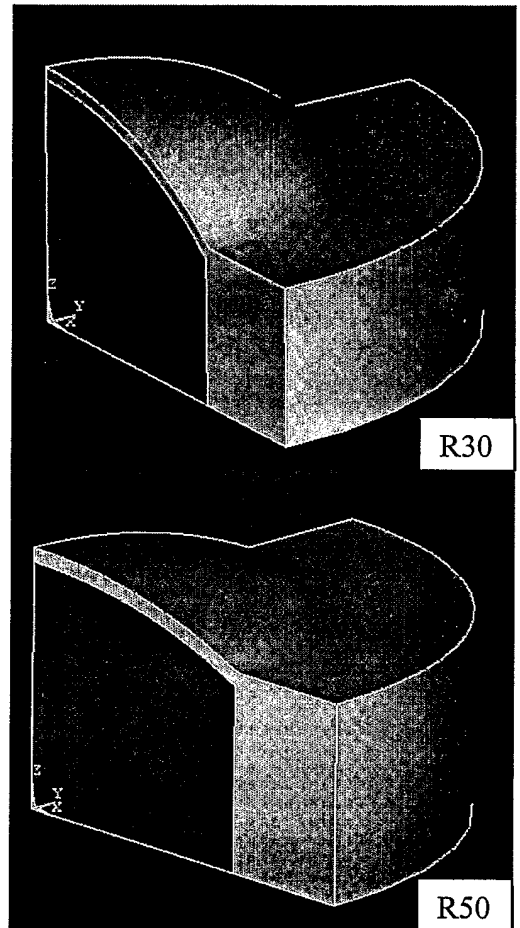
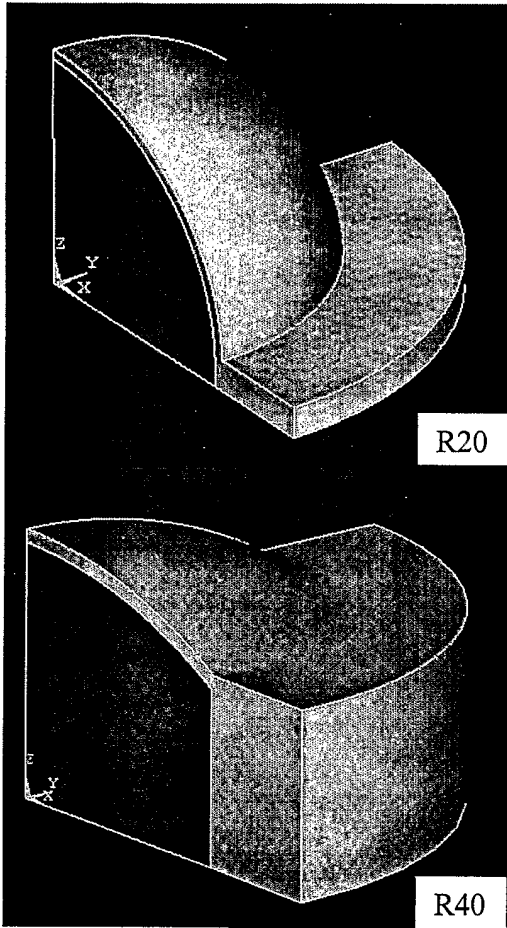

FIGURE 6

6/8

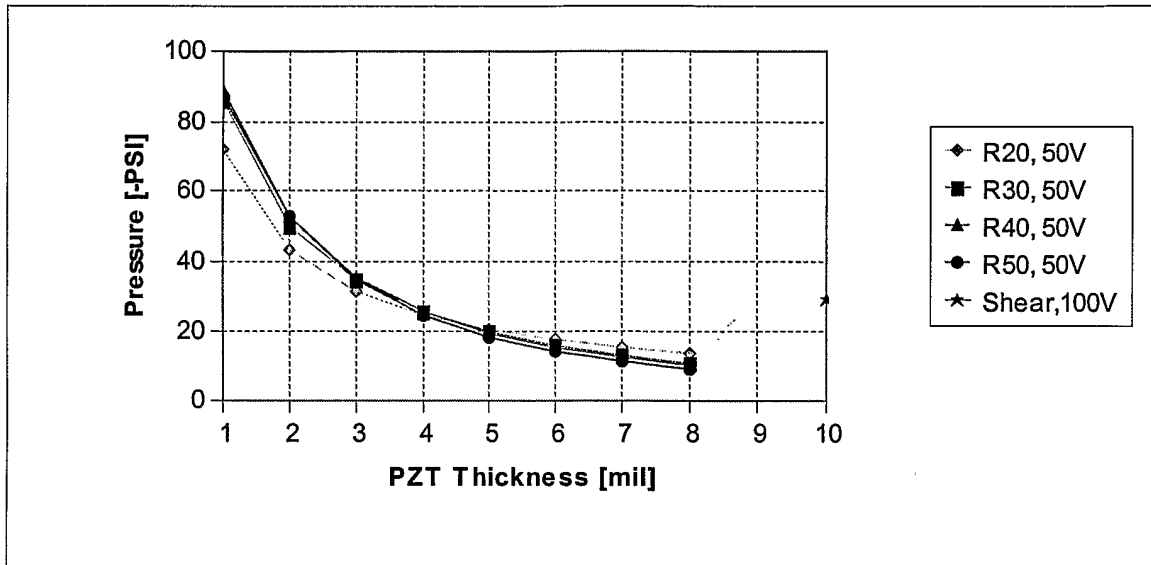

FIGURE 7

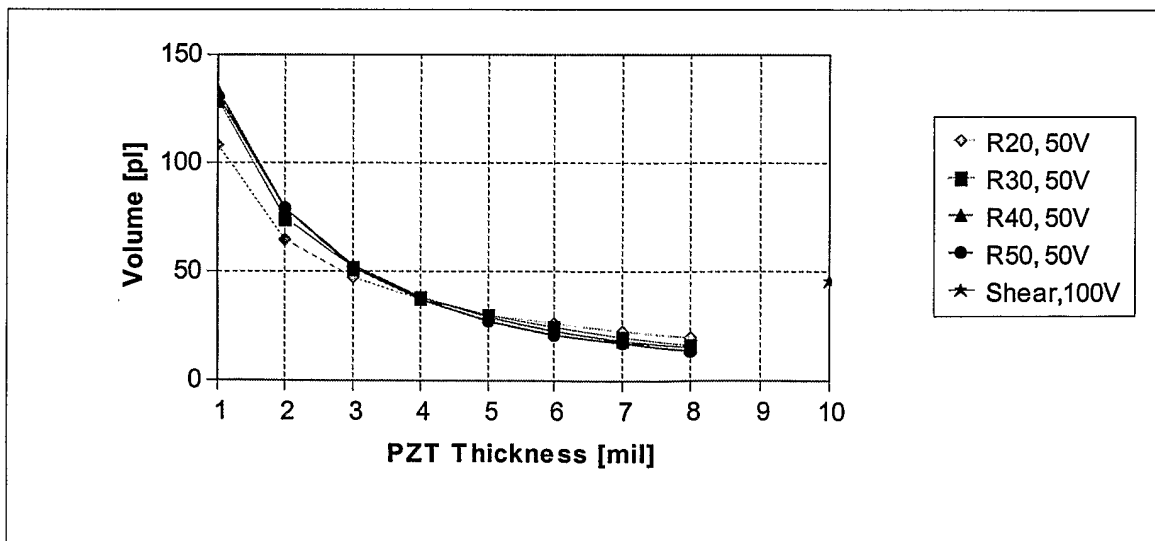

FIGURE 8

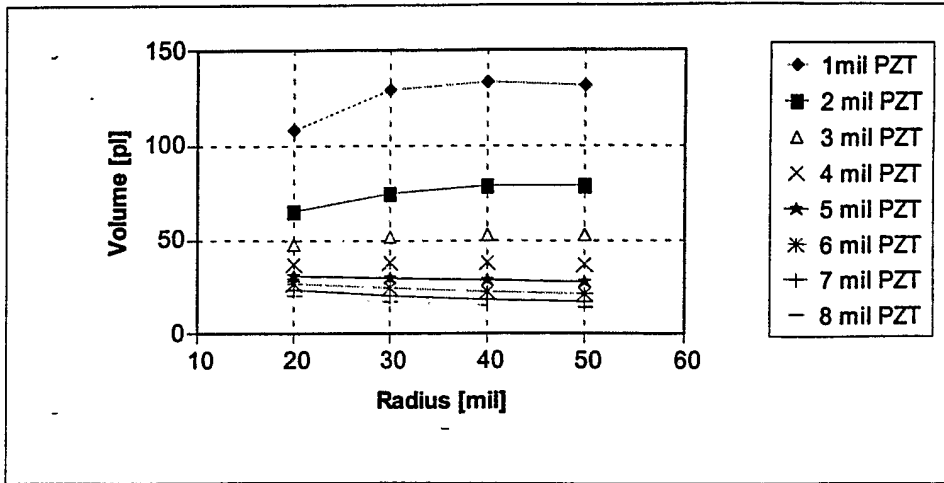

FIGURE 9

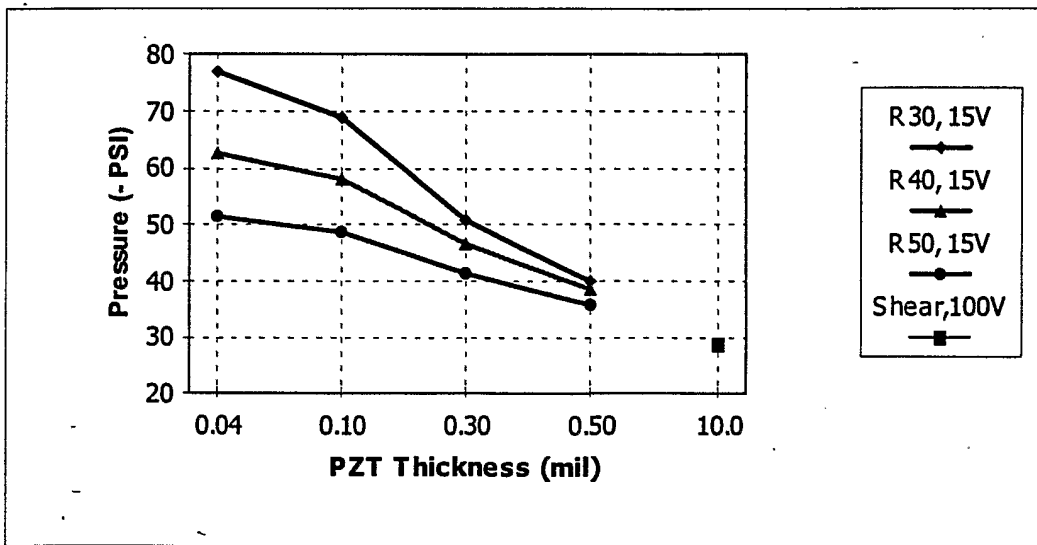

FIGURE 10

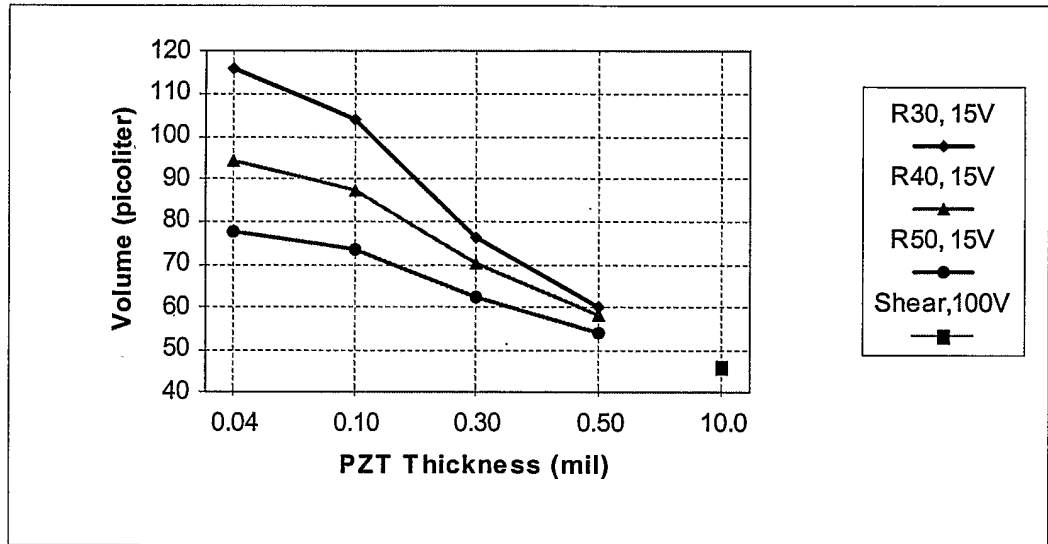

FIGURE 11